

(No Model.)

3 Sheets—Sheet 1.

A. W. HARRISON.
ART OF MAKING ELECTROTYPES.

No. 523,836.

Patented July 31, 1894.

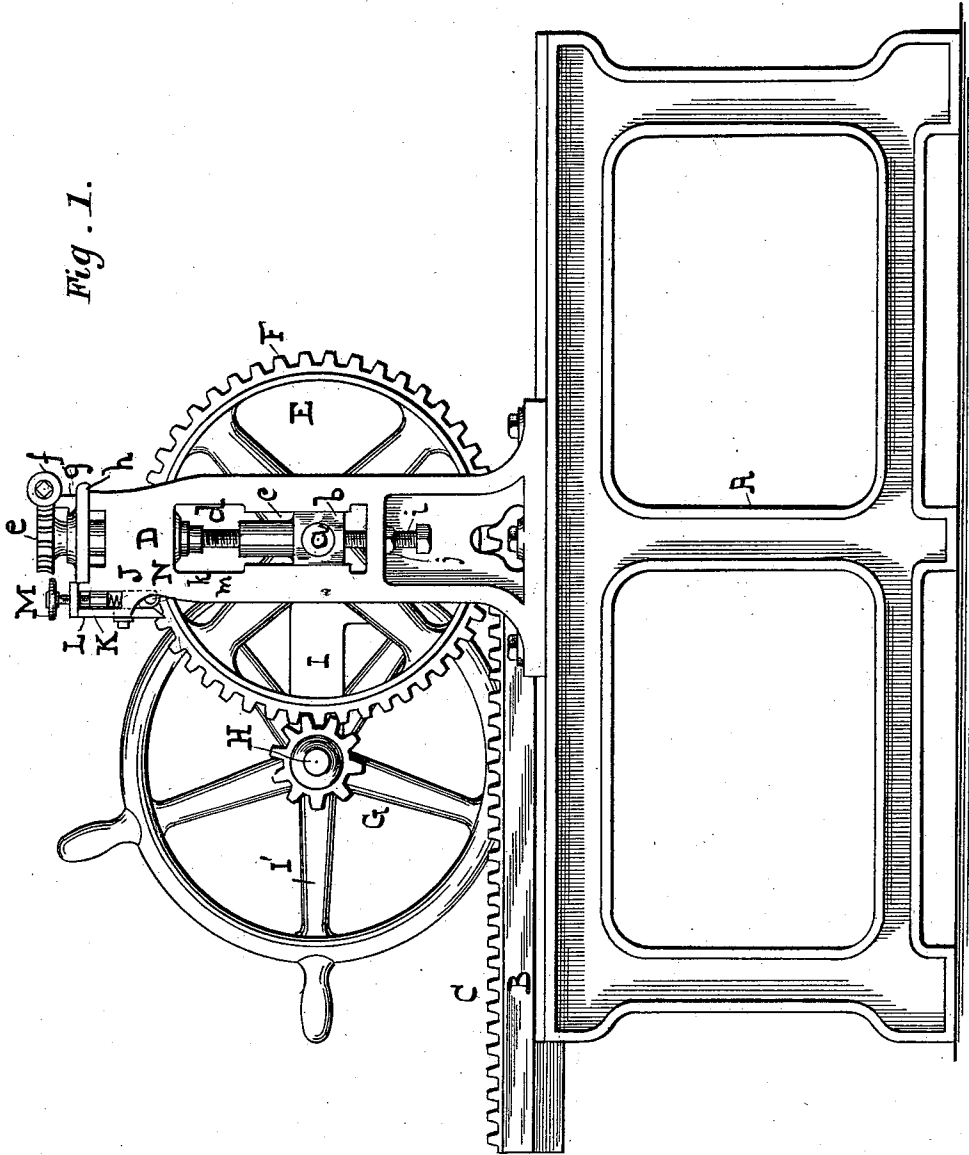

-WITNESSES-

Don C. Fisher
Howard S. Koch

INVENTOR

Albert W. Harrison,
by W. J. Howard,
att'y.

A. W. HARRISON.
ART OF MAKING ELECTROTYPES.

No. 523,836.

Patented July 31, 1894.

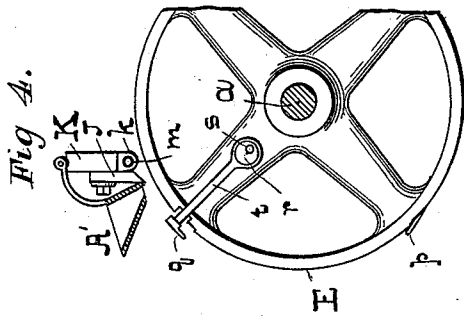

Fig. 4.

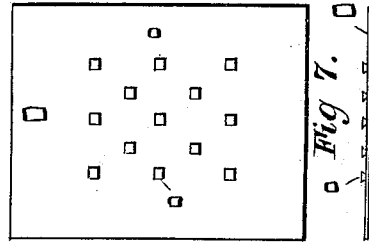

Fig. 6.

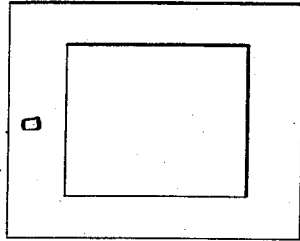

Fig. 5.



Fig. 7.

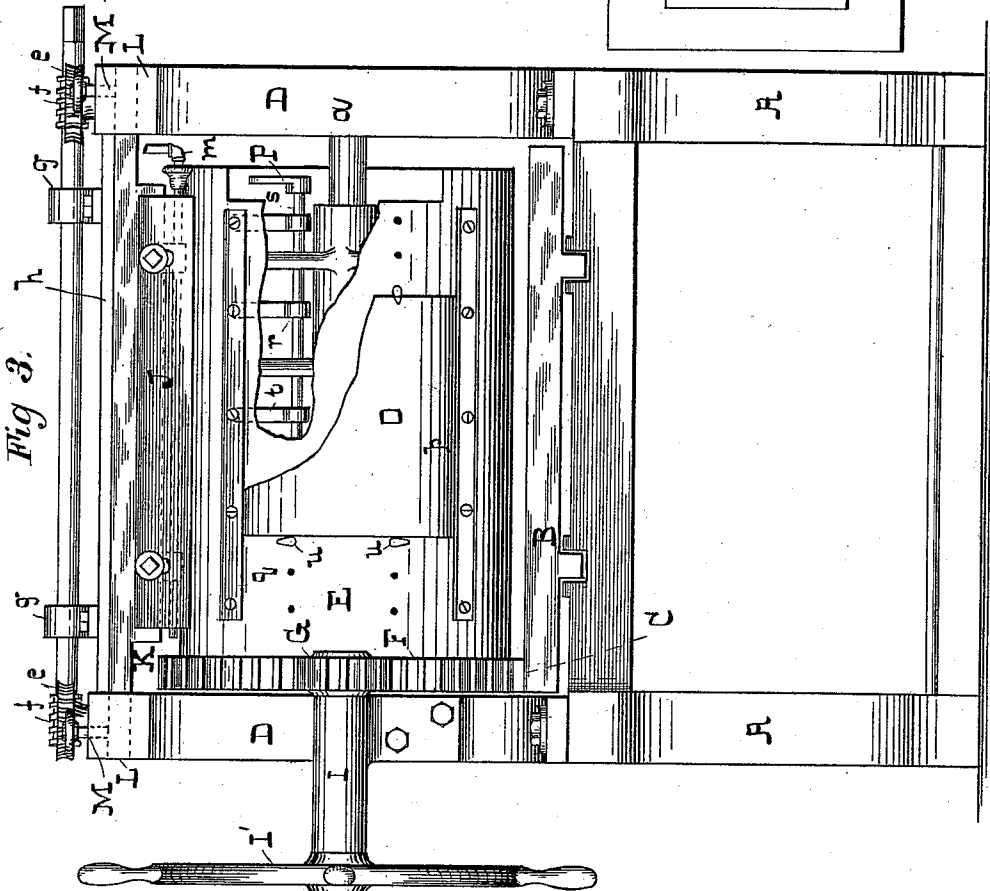

Fig. 3.

-WITNESSES-

Dan'l Fisher
Howard K. Koch

-INVENTOR-

Albert W. Harrison
by G. W. T. Howard
att'y.

UNITED STATES PATENT OFFICE.

ALBERT W. HARRISON, OF BALTIMORE, MARYLAND.

ART OF MAKING ELECTROTYPES.

SPECIFICATION forming part of Letters Patent No. 523,836, dated July 31, 1894.

Application filed March 11, 1892. Serial No. 424,513. (No model.)

To all whom it may concern:

Be it known that I, ALBERT W. HARRISON, of the city of Baltimore and State of Maryland, have invented certain Improvements in the Art of Making Electrotypes, of which the following is a specification.

The portion of the operation of making electrotypes involved in this invention is that in which the matrix of wax is formed from type or a cut.

The operation of making a wax matrix in accordance with the present invention consists in placing an ordinary chase, upon a flexible flat plate preferably spring brass and pouring within the chase a body of melted wax to a thickness which is greater than the matrix is required to be. In order that the union of the wax and the flexible spring plate may be complete and of such a character as to withstand the various manipulations to which they are subjected, I provide the plate with dovetailed projections or cleats which serve to anchor the wax thereon. After pouring the wax in the chase, it is allowed to cool, when the chase is removed by cutting the wax at the junction of the wax and chase. The flexible plate with its wax covering, is then applied to a revoluble cylinder, and held thereto in a curved position by means of suitable buttons and clamps. The cylinder is mounted on a suitable frame and is situated over a sliding bed which has a rack adapted to engage with a gear wheel on the end of the cylinder. After the attachment of the flexible plate to the cylinder the latter is revolved which has the effect of bringing the wax on the plate in contact with a fixed knife which is heated by gas flames so that in the planing operation the outer surface of the wax is smoothly shaved off and the remaining portion or that left on the curved plate, brought to a uniform thickness which is governed by the position of the knife with reference to the circumference of the cylinder. The type or cut from which the matrix is to be made is now placed on the sliding bed and after the exposed surface of the wax has been coated with plumbago to prevent its sticking to the type or cut, the bed carrying the same is drawn under the cylinder and the impression

in the wax formed. The flexible plate and wax are now removed from the cylinder after which a proper coating of plumbago is applied when the whole is placed in the bath employed to effect the disposition of copper on the wax.

The machine and appliances which I employ in carrying out the method above described are shown in the accompanying drawings forming a part hereof, and in which—

Figure 1 is an exterior side elevation of the machine and Fig. 2 a plan of the same. Fig. 3 is a front view of the machine and Fig. 4 a detail of the same. Fig. 5 is a top view of the flexible spring plate and the body of wax, and Fig. 6 is a similar view of the plate alone. Fig. 7 is an edge view of Fig. 6.

In the said drawings A is a frame, and B a sliding bed having a rack C at one edge.

D D are stands erected on the frame A, and E is a hollow cylinder with a gear F at one end, the teeth of which are adapted to engage with those of the rack C.

The spindle or shaft *a* of the cylinder is confined in bearing boxes *b* adapted to slide in slots *c* in the stands D. The vertical position of the bearing boxes *b* is regulated by means of screws *d* the upper ends of which are provided with worm wheels *e* in engagement with a worm *f*. This worm is supported by brackets *g* bolted to the top of a plate *h* extending between the stands D. After the cylinder is brought to the required height it is fixed by the set screws *i* and the locking nuts *j*. The revolution of the cylinder E is effected by means of a pinion G on a shaft H adapted to be revolved in a bracket I bolted to one of the stands D. Motion of the shaft is produced by hand through the medium of the hand wheel I', or by other means.

J is an adjustable knife bolted to the bar K the ends of which rest in boxes L formed on the side of the stands D. A downward movement of the bar K and its knife is obtained by screws M, and an upward motion is effected by the spiral springs N when the screws M are released from contact with the bar.

Referring particularly to Figs. 3 and 4, it will be seen that the bar K has two lugs *k*

through which a gas pipe *m* is inserted. This pipe is perforated for the escape of gas, and one end is closed.

The gas pipe may be turned or partially rotated so as to make the gas flames play either on the knife or the cylinder, the latter effect only being required when the cylinder is extremely cold. By means of this gas pipe the knife *J* is retained in a slightly heated condition or sufficiently hot to enable it to cut the wax without tearing it.

The flexible spring plate before alluded to is represented by *O*, and the dovetailed projections thereon by *o*.

When the flexible spring plate is applied to the cylinder its lower edge is held by a strip *p*, and its upper edge by a strip *q* which is movable through the medium of a series of eccentrics *r* on a shaft *s* which passes through one of the arms of the hollow cylinder *E*, and eccentric rods *t* which connect the eccentrics with the strip. The shaft *s* and its eccentrics *r* are operated by a lever *P* at one end of the shaft. A portion of the cylinder is removed to give access to the lever *P*, see Fig. 3. The portion of the flexible plate between the ends is held by means of buttons *u* shown particularly in Fig. 3. These buttons are on threaded stems inserted in threaded holes in the surface of the cylinder. A series of these holes are used so that the buttons may be placed on the cylinder at such distances apart as may be required to suit the width of the plate.

A' is a tray hinged to the bar *K* to receive the wax sheared off the knife *J*, and prevent its falling to the cylinder or sliding bed.

I claim as my invention—

1. The method herein described of preparing matrices for electrotypes, which consists in first uniting the wax to a flexible backing plate, then bending said plate and wax and attaching them to a revoluble cylindrical body, then making the impression in the wax by bringing it into contact with the type or cut by a rolling movement, and then depositing metal thereon, substantially as specified.

2. In a machine for planing wax to be used in the formation of matrices for electrotypes, the combination with a rotary cylinder, of a fixed strip on the surface of said cylinder to engage one edge of the wax body, a movable strip to engage the opposite edge of the wax body, a rotary shaft journaled in the cylinder, eccentrics carried by the shaft, and eccentric rods connecting the eccentrics with the movable strip, substantially as described.

3. In a machine for planing the surface of a wax matrix, the combination of a rotary cylinder, a stationary knife and a gas pipe having a circumferential movement whereby the gas flame projecting therefrom may be turned against either the knife or the cylinder, substantially as specified.

ALBERT W. HARRISON.

Witnesses:

DANL. FISHER,
WM. T. HOWARD.