

R. E. L. GRUBBS.
 APPARATUS FOR TREATING GRAIN.
 APPLICATION FILED NOV. 7, 1910.

997,992.

Patented July 18, 1911.

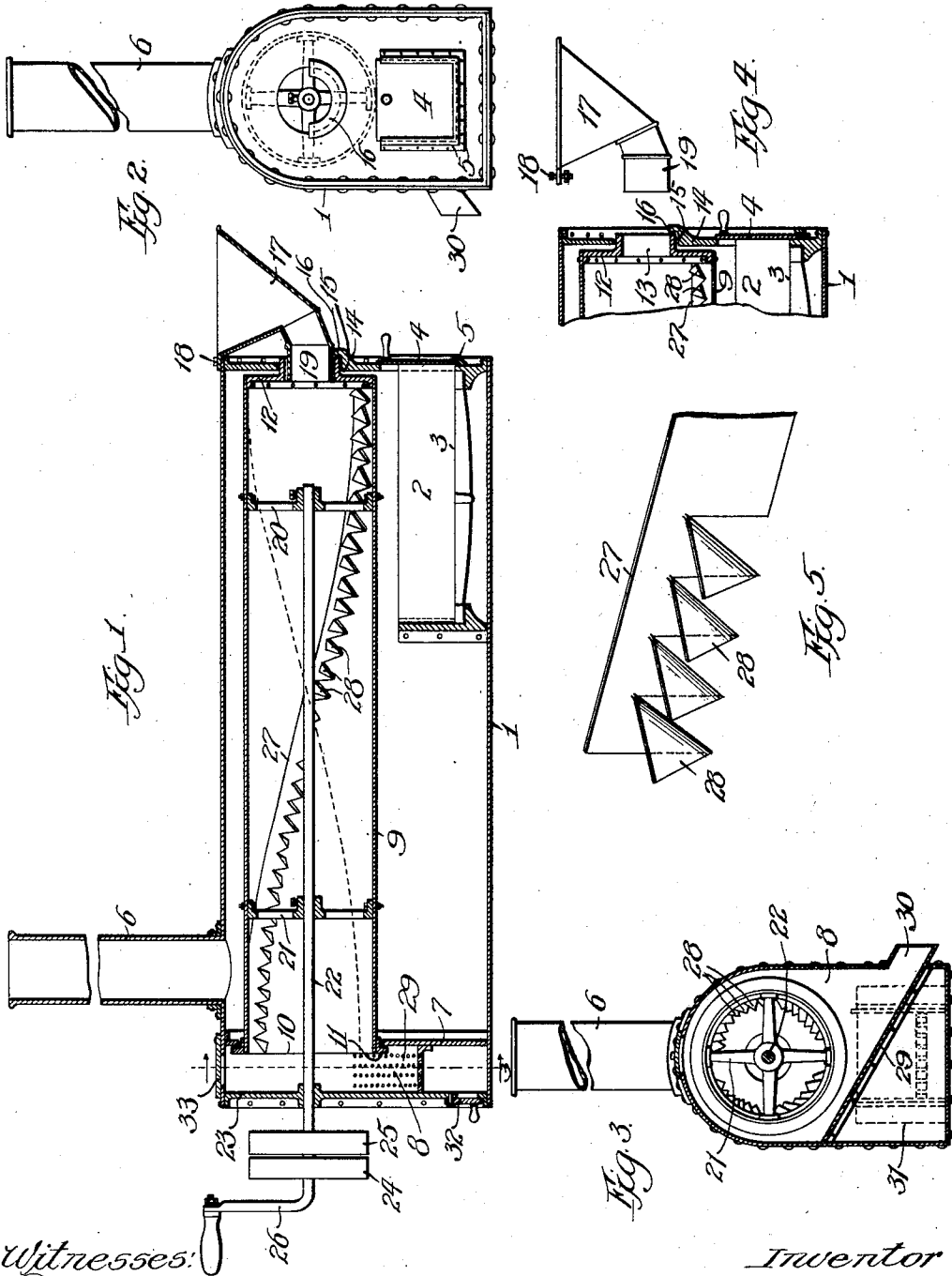

Witnesses:
 E. C. Devine
 C. H. Crawford

Inventor
 Robert E. L. Grubbs.
 By B. Singer, Atty.

UNITED STATES PATENT OFFICE.

ROBERT E. L. GRUBBS, OF SAN JOAQUIN, CUBA.

APPARATUS FOR TREATING GRAIN.

997,992.

Specification of Letters Patent. Patented July 18, 1911.

Application filed November 7, 1910. Serial No. 591,137.

To all whom it may concern:

Be it known that I, ROBERT E. L. GRUBBS, a citizen of the United States, residing at San Joaquin, No. 1 Camaguey, Cuba, have invented new and useful Improvements in Apparatus for Treating Grain, of which the following is a specification.

This invention refers to improvements in apparatus for treating grain, especially cereal farina and fecula grains for the purposes of desiccating the same with a view of removing a portion of the moisture therefrom. This feature of the invention also has for its object the destruction of such germs and bacilli, of a pathological nature, as may be destroyed by the degrees of temperature to which the grain is subjected in drying the same. The heat applied to the grain also has for its object the destruction of all insects, among the most prevalent of which is weevil and similar insects which propagate in stored grain.

The invention has for its object the provision of a furnace constructed with a revoluble body therein and the apparatus is so designed and arranged that the process of treating the grain may continue without interruption.

The invention has for its object a feature of novelty which will be more fully described in connection with the accompanying drawing and which will be more particularly pointed out and ascertained in and by the appended claims.

In the drawing—Figure 1 is a longitudinal sectional view of an apparatus embodying the main features of my invention. Fig. 2 is an end elevation looking toward the feed end of the apparatus. Fig. 3 is a sectional view of line 3—3 of Fig. 1. Fig. 4 is a sectional view of the feed end with the feed hopper removed. Fig. 5 is a perspective detailed view of one of the parts of the apparatus.

Like numerals of reference designate like parts throughout the different figures of the drawing.

The apparatus shown includes a heating chamber or furnace designated at 1 and provided with a fire box 2 and a grate 3. A fuel door 4 is shown mounted in guides 5 and an outlet or stack 6 is provided, as shown. One

end of the furnace 1 is divided by a partition 7 to provide a suitable discharge chamber 8. 55

Within the furnace 1 there is provided a revolubly mounted body preferably in the form of a cylinder 9 which is provided with an open end 10 which projects through the partition 7 and forms the outlet or discharge end for the grain. The cylinder 9 may be provided with a bearing ring 11 which, in cross section, is in the form of an angle with one flange overlapping the inner face of the partition 7. At its opposite end said cylinder 9 is provided with an end wall 12 having a tubular extension or bearing portion 13 adapted to be journaled in the wall 14 of the furnace. To this end the wall 14 is provided with a semi-circular bearing portion 15 having an upwardly projecting flange 16. The tubular extension 13 is hollow and is adapted to form the intake end for the cylinder 9. 60 65 70

A feed hopper 17 may be secured by any suitable means, such as a bolt 18, to the furnace 1, and is provided with a cylindrical extension 19 which feeds into the tubular extension 13, as clearly shown in Fig. 1. 75

The cylinder 9 is provided on its interior and between or inside of its ends with shaft supporting elements preferably in the form of spiders 20 and 21. An operating shaft 22 is anchored to said spiders 20 and 21 and is also journaled in the wall of the furnace 1, as clearly shown in Fig. 1. The shaft 23 carries fast and loose pulleys 24 and 25 for power propulsion and may also be provided with a shaft 26 for manual operation. 80 85

It will be seen that the foregoing construction is particularly advantageous in an apparatus of this character because it permits of a centrally or axially free entrance of the grain or material and the latter during such feed does not in any way engage the operating shaft or bearing portions. It will also be seen that the outlet 10 affords a free and unrestricted opening for the discharge of material. 90 95

The revolving body or cylinder 9 is provided with means for moving and longitudinally advancing the grain therein during rotation of said body and said means is so constructed and arranged that in the act of 100

discharging the material the same is advanced longitudinally of said body. As shown, said means comprises strips of metal 27 which are longitudinally and spirally disposed in said cylinder 9 and which, in the form shown, extend from the intake to the discharge end thereof. Said strips are also shown having a spiral disposition of less than a complete circle so that the same do not intersect each other. The margins of said strips, as shown in Fig. 5, are slitted and bent forwardly in a direction generally parallel with the longitudinal axis of the cylinder 9 or the direction in which the material therein is advanced, said forwardly bent portions being indicated at 28. It will be seen by reference to Fig. 5 that the bent portions or projections 28 are also disposed at a slight angle with respect to the longitudinal axis of said cylinder 9, thereby providing forwardly inclined pockets into which the material falls and is lifted as the cylinder 9 rotates. These forwardly inclined pockets serve to discharge the material in a forward direction and thereby act to advance the material when so discharged. It will be readily seen that when the cylinder 9 is rotating the material will be continually caught in said pockets and discharged therefrom, so that the material will continually be changed in position with respect to the cylinder 9 and continually advanced therein from the intake for the discharge end. While the material is being subjected to this stirring action it is subjected to the products of combustion from the fire-box to a temperature which approximates 212° F., a temperature sufficient to destroy or at least practically destroy any germs and to wholly destroy any insects. During the passage of the grain through the body 9 the process of desiccation will be completed and the grain will be discharged into the chamber 8.

In the chamber 8 an inclined wall 29 directs the discharged grain to a chute 30. The inclined wall 29 may be provided with perforations through which the refuse may descend into a lower chamber 31. A door 32 may be provided for removing the dross which collects in the chamber 31 and a pivot flap 33 may be provided for the chamber 8, to control, or if desired, to wholly cut off the discharge of steam resulting from the drying of the grain.

I claim:—

1. An apparatus for treating grain comprising in combination, a revoluble receptacle for receiving the grain, strips disposed spirally in said receptacle and throughout less than a complete circle therein, said strips having teeth or projections thereon extending forwardly in the path of travel

of the grain to engage and advance the grain when discharged therefrom, and means for heating the grain in said receptacle.

2. An apparatus for treating grain comprising in combination, a furnace chamber, a revoluble body arranged in said furnace chamber, a hollow member arranged at one end of said revoluble body and forming a bearing therefor, means arranged to deliver grain into said hollow member and into said revoluble body, means in said body for stirring and advancing the grain, an operating shaft rotatably mounted in said furnace and secured to said body, a chamber arranged at the forward end of the furnace in the wall of which the discharge end of the revoluble body has bearing, and an inclined wall arranged in said chamber onto which the material is discharged from said revoluble body, said wall being provided with perforations to allow of the escape of impurities.

3. An apparatus for treating grain comprising in combination, a furnace chamber, a revoluble receptacle arranged in said furnace having an opening at one end and a tubular extension at said opening forming a bearing for said receptacle, strips disposed spirally in said receptacle and throughout less than a complete circle therein, said strips being provided with members adapted to engage and advance the grain when discharged therefrom, and a chamber at the forward end of the furnace in the wall of which the receptacle has bearing, said chamber being adapted to receive the material discharged from said receptacle.

4. An apparatus for treating grain comprising in combination, a furnace chamber, a revoluble body therein for receiving grain and provided with bearing portions between its ends, a revolubly mounted shaft extending through one end of said body and secured to said portions, means forming a bearing for the opposite end of said body and strips disposed spirally in said body, said strips having teeth or projections thereon extending forwardly in the path of travel of the grain to engage and advance the grain when discharged therefrom.

5. An apparatus for treating grain comprising in combination, a furnace chamber, a revoluble cylinder therein having a hollow bearing member at its intake end journaled in said furnace, means delivering the grain to said hollow bearing and into said cylinder, bearing portions secured in said cylinder between the ends thereof to provide unrestricted inlet and outlet ends, an operating shaft rotatably mounted in said furnace and secured to said portions, strips disposed spirally in said cylinder and

throughout less than a complete circle there-
in, said strips having teeth or projections
thereon extending forwardly in the path of
travel of the grain to engage and advance
5 the grain when discharged therefrom, and a
discharge chamber for said cylinder receiv-
ing the grain therefrom, the bottom wall of
said chamber being provided with perfora-

tions through which the refuse may be re-
moved from the grain.

In testimony whereof I affix my signature
in presence of two witnesses.

ROBERT E. L. GRUBBS.

Witnesses:

M. H. CANN,
DEAN R. WOOD.

Copies of this patent may be obtained for five cents each, by addressing the "Commissioner of Patents,
Washington, D. C."