



US010127352B1

(12) **United States Patent**
Florissi et al.

(10) **Patent No.:** **US 10,127,352 B1**
(45) **Date of Patent:** **Nov. 13, 2018**

(54) **DISTRIBUTED DATA PROCESSING PLATFORM FOR METAGENOMIC MONITORING AND CHARACTERIZATION**

(56) **References Cited**

U.S. PATENT DOCUMENTS

(71) Applicant: **EMC Corporation**, Hopkinton, MA (US)

- 6,516,350 B1 2/2003 Lumelsky et al.
- 7,934,018 B1 4/2011 Lavallee et al.
- 8,806,061 B1 8/2014 Lobo et al.
- 9,020,802 B1 4/2015 Florissi et al.
- 9,031,992 B1 5/2015 Florissi et al.

(Continued)

(72) Inventors: **Patricia Gomes Soares Florissi**, Briarcliff Manor, NY (US); **Michal Ziv Ukelson**, Lehavim (IL); **Ran Dach**, Kiryat Yam (IL); **Arnon Benshahar**, Tel Aviv (IL); **Ehud Gudes**, Beer-Sheva (IL)

OTHER PUBLICATIONS

Gardner et al. Parallel genomic sequence-searching on an ad-hoc grid: experiences, lessons learned, and implications. Proceedings of the 2006 ACM/IEEE SC/06 Conference, IEEE Computer Society, 14 pages. (Year: 2006).*

(Continued)

(73) Assignee: **EMC IP Holding Company LLC**, Hopkinton, MA (US)

Primary Examiner — Russell S Negin

(74) *Attorney, Agent, or Firm* — Ryan, Mason & Lewis, LLP

(*) Notice: Subject to any disclaimer, the term of this patent is extended or adjusted under 35 U.S.C. 154(b) by 248 days.

(21) Appl. No.: **14/983,991**

(57) **ABSTRACT**

(22) Filed: **Dec. 30, 2015**

A method comprises configuring a first processing node for communication with one or more additional processing nodes and with one or more of a plurality of geographically-distributed metagenomics sequencing centers via one or more networks, processing metagenomics sequencing results obtained from one or more of the metagenomics sequencing centers in the first processing node, and providing surveillance functionality relating to at least one designated biological issue on behalf of one or more requesting clients based at least in part on the processing of metagenomics sequencing results performed by the first processing node and related processing performed by one or more of the additional processing nodes. Each of the metagenomics sequencing centers is configured to perform metagenomics sequencing on biological samples from respective sample sources in a corresponding data zone.

Related U.S. Application Data

(60) Provisional application No. 62/143,404, filed on Apr. 6, 2015, provisional application No. 62/143,685, filed on Apr. 6, 2015.

(51) **Int. Cl.**
G01N 33/48 (2006.01)
G01N 33/50 (2006.01)
G06F 19/22 (2011.01)

(52) **U.S. Cl.**
CPC **G06F 19/22** (2013.01)

(58) **Field of Classification Search**
None
See application file for complete search history.

20 Claims, 23 Drawing Sheets

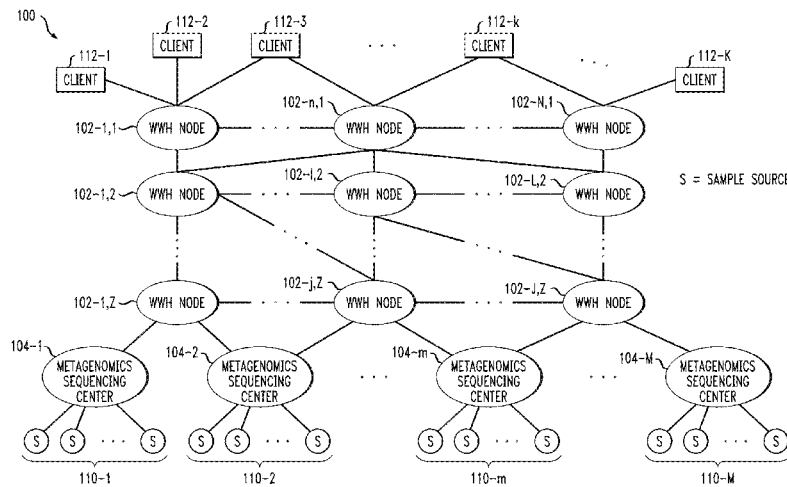

(56)

References Cited

U.S. PATENT DOCUMENTS

9,158,843	B1	10/2015	Florissi et al.	
9,280,381	B1	3/2016	Florissi et al.	
9,338,218	B1	5/2016	Florissi et al.	
9,361,263	B1	6/2016	Florissi et al.	
9,489,233	B1	11/2016	Florissi et al.	
9,747,127	B1	8/2017	Florissi et al.	
9,747,128	B1	8/2017	Vijendra et al.	
9,996,662	B1	6/2018	Florissi et al.	
10,015,106	B1	7/2018	Florissi et al.	
2002/0073167	A1	6/2002	Powell et al.	
2005/0010712	A1	1/2005	Kim et al.	
2005/0102354	A1	5/2005	Hollenbeck et al.	
2005/0114476	A1	5/2005	Chen et al.	
2006/0002383	A1	1/2006	Jeong et al.	
2006/0122927	A1	6/2006	Huberman et al.	
2007/0026426	A1	2/2007	Fuernkranz et al.	
2007/0076703	A1	4/2007	Yoneda et al.	
2007/0088703	A1	4/2007	Kasiolas et al.	
2008/0027954	A1	1/2008	Gan et al.	
2008/0028086	A1	1/2008	Chetuparambil et al.	
2008/0077607	A1*	3/2008	Gatawood	H03M 7/3084
2008/0279167	A1	11/2008	Cardei et al.	
2010/0076856	A1	3/2010	Mullins	
2010/0131639	A1	5/2010	Narayana et al.	
2010/0184093	A1	7/2010	Donovan et al.	
2010/0229178	A1	9/2010	Ito	
2010/0290468	A1	11/2010	Lynam et al.	
2010/0299437	A1	11/2010	Moore	
2011/0020785	A1	1/2011	Lowery, Jr. et al.	
2011/0103364	A1	5/2011	Li	
2011/0314002	A1	12/2011	Oliver et al.	
2013/0035956	A1	2/2013	Carmeli et al.	
2013/0194928	A1	8/2013	Iqbal	
2013/0246460	A1	9/2013	Maltbie et al.	
2013/0318257	A1	11/2013	Lee et al.	
2014/0012843	A1*	1/2014	Soon-Shiong	G06F 19/18 707/736
2014/0280363	A1	9/2014	Heng et al.	
2014/0280604	A1	9/2014	Ahiska et al.	
2014/0280990	A1	9/2014	Dove et al.	
2014/0310718	A1	10/2014	Gerphagnon et al.	
2014/0325041	A1	10/2014	Xu et al.	
2014/0372611	A1	12/2014	Matsuda et al.	
2015/0019710	A1	1/2015	Shaashua et al.	
2015/0088786	A1	3/2015	Anandhakrishnan	
2015/0178052	A1	6/2015	Gupta et al.	
2015/0269230	A1	9/2015	Kardes et al.	
2015/0295781	A1	10/2015	Maes	
2016/0072726	A1	3/2016	Soni et al.	
2016/0098021	A1	4/2016	Zorino et al.	
2016/0179979	A1	6/2016	Aasman et al.	
2016/0205106	A1	7/2016	Yacoub et al.	
2016/0267132	A1	9/2016	Castellanos et al.	
2016/0337473	A1	11/2016	Rao	
2017/0032263	A1	2/2017	Yuan et al.	
2017/0187785	A1	6/2017	Johnson et al.	
2018/0054355	A1	2/2018	Balsler et al.	

OTHER PUBLICATIONS

Craig et al. Ordering of cosmid clones covering the Herpes simplex virus type I (HSV-I) genome: a test case for fingerprinting by hybridisation. *Nucleic Acids Research*, vol. 18, pp. 2653-2660. (Year: 1990).*

V.K. Vavilapalli et al., "Apache Hadoop YARN: Yet Another Resource Negotiator," Proceedings of the 4th Annual Symposium on Cloud Computing (SOCC), Article No. 5, Oct. 2013, 16 pages.

A.C. Murthy et al., "Apache Hadoop YARN: Moving beyond MapReduce and Batch Processing with Apache Hadoop 2," Addison-Wesley Professional, Mar. 29, 2014, 78 pages.

Global Alliance for Genomics and Health, "Beacons," <https://genomicsandhealth.org/work-products-demonstration-projects/beacons>, Jun. 27, 2014, 2 pages.

Data Working Group, "Global Alliance Genomics API," <http://ga4gh.org/#/documentation>, Dec. 28, 2015 2 pages.

Aaron Krol, "Beacon Project Cracks the Door for Genomic Data Sharing," <http://www.bio-itworld.com/2015/8/14/beacon-project-cracks-door-genomic-data-sharing.html>, Aug. 14, 2015, 3 pages.

U.S. Appl. No. 15/281,248 filed in the name of Patricia Gomes Soares Florissi et al., filed Sep. 30, 2016 and entitled "Methods and Apparatus Implementing Data Model for Disease Monitoring, Characterization and Investigation."

P.P. Jayaraman et al., "Analytics-as-a-Service in a Multi-Cloud Environment Through Semantically-Enabled Hierarchical Data Processing," *Software: Practice and Experience*, Aug. 2017, pp. 1139-1156, vol. 47, No. 8.

J.Y.L. Lee et al., "Sufficiency Revisited: Rethinking Statistical Algorithms in the Big Data Era," *The American Statistician*, Dec. 15, 2016, 22 pages.

S. Wang et al., "Genome Privacy: Challenges, Technical Approaches to Mitigate Risk, and Ethical Considerations in the United States," *Annals of the New York Academy of Sciences*, Jan. 2017, pp. 73-83, vol. 1387, No. 1.

K. Xu et al., "Privacy-Preserving Machine Learning Algorithms for Big Data Systems," *IEEE 35th International Conference on Distributed Computing Systems (ICDCS)*, Jun. 29-Jul. 2, 2015, pp. 318-327.

T.R. Golub et al., "Molecular classification of Cancer: Class Discovery and Class Prediction by Gene Expression Monitoring," *Science*, vol. 286, Oct. 15, 1999, pp. 531-537.

D. Singh et al., "Expression Correlates of Clinical Prostate Cancer Behavior," *Cancer Cell*, vol. 1, Mar. 2002, pp. 203-209.

U.S. Appl. No. 14/982,341 filed in the name of Patricia Gomes Soares Florissi et al., filed Dec. 29, 2015 and entitled "Multi-Cluster Distributed Data Processing Platform."

U.S. Appl. No. 14/982,351 filed in the name of Patricia Gomes Soares Florissi et al., filed Dec. 29, 2015 and entitled "Distributed Catalog Service for Multi-Cluster Data Processing Platform."

U.S. Appl. No. 15/395,340 filed in the name of Bryan Duerk et al., filed Dec. 30, 2016 and entitled "Data-Driven Automation Mechanism for Analytics Workload Distribution."

Wikipedia, "Apache Spark," https://en.wikipedia.org/wiki/Apache_Spark, Apr. 10, 2017, 6 pages.

U.S. Appl. No. 15/485,843 filed in the name of Patricia Gomes Soares Florissi et al., filed Apr. 12, 2017 and entitled "Scalable Distributed In-Memory Computation."

U.S. Appl. No. 15/582,743 filed in the name of Patricia Gomes Soares Florissi et al., filed Apr. 30, 2017 and entitled "Scalable Distributed In-Memory Computation Utilizing Batch Mode Extensions."

Dell, "Dell Boomi Platform: Connect Every Part of Your Business to Transform How You do Business," <https://marketing.boomi.com/rs/777-AVU-348/images/Boomi-Integration-Cloud.pdf>, 2017, 4 pages.

X. Wu et al., "Privacy Preserving Data Mining Research: Current Status and Key Issues," Proceedings of the 7th International Conference on Computational Science, Part III: ICCS 2007, May 2007, pp. 762-772.

* cited by examiner

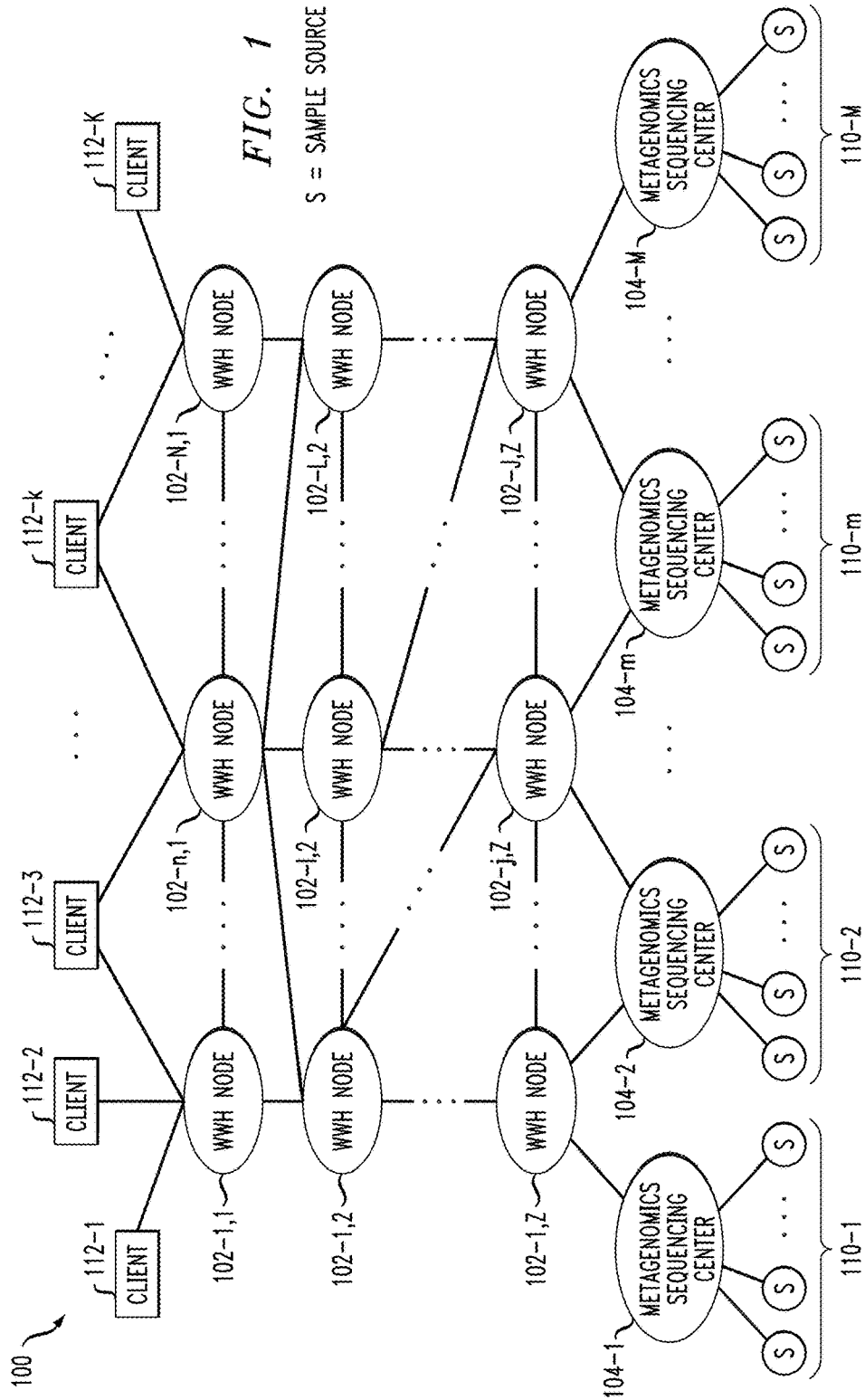
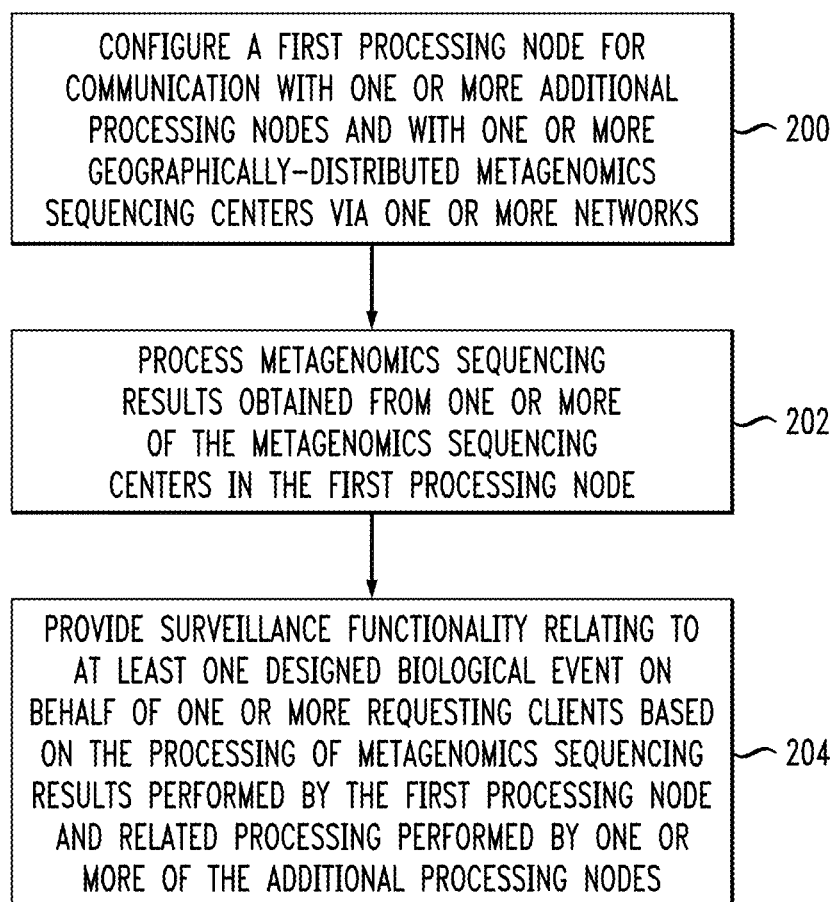

FIG. 1

S = SAMPLE SOURCE

FIG. 2



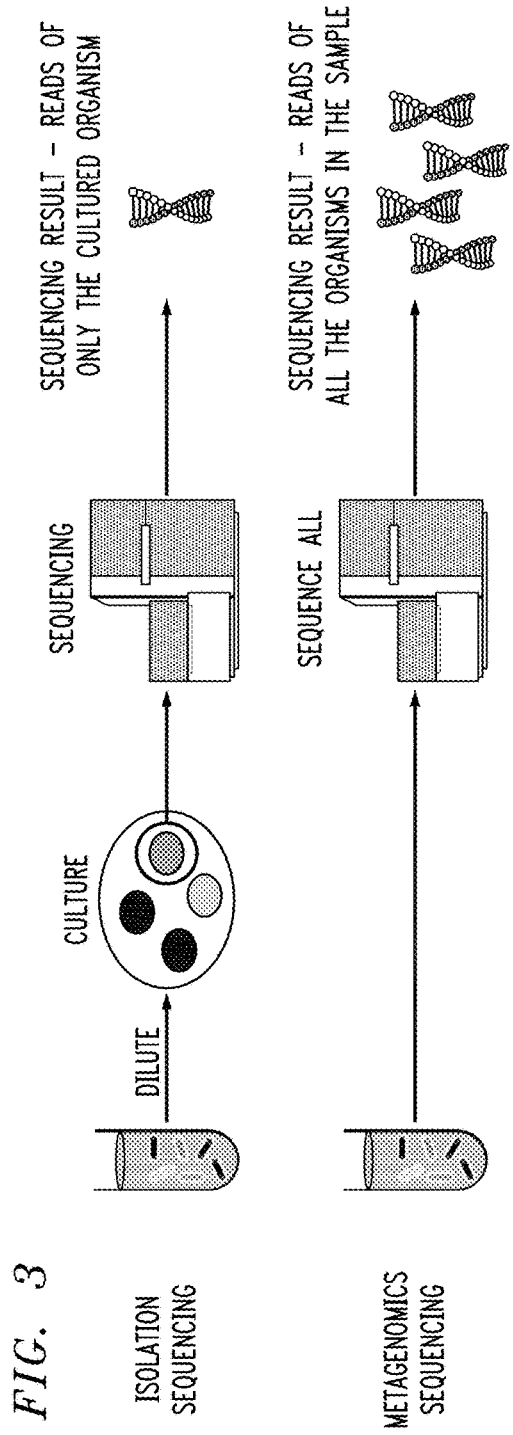

FIG. 4

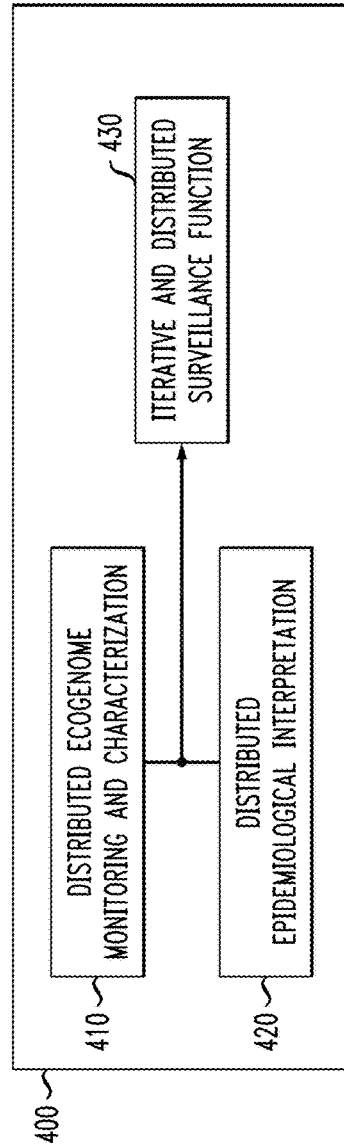

FIG. 5

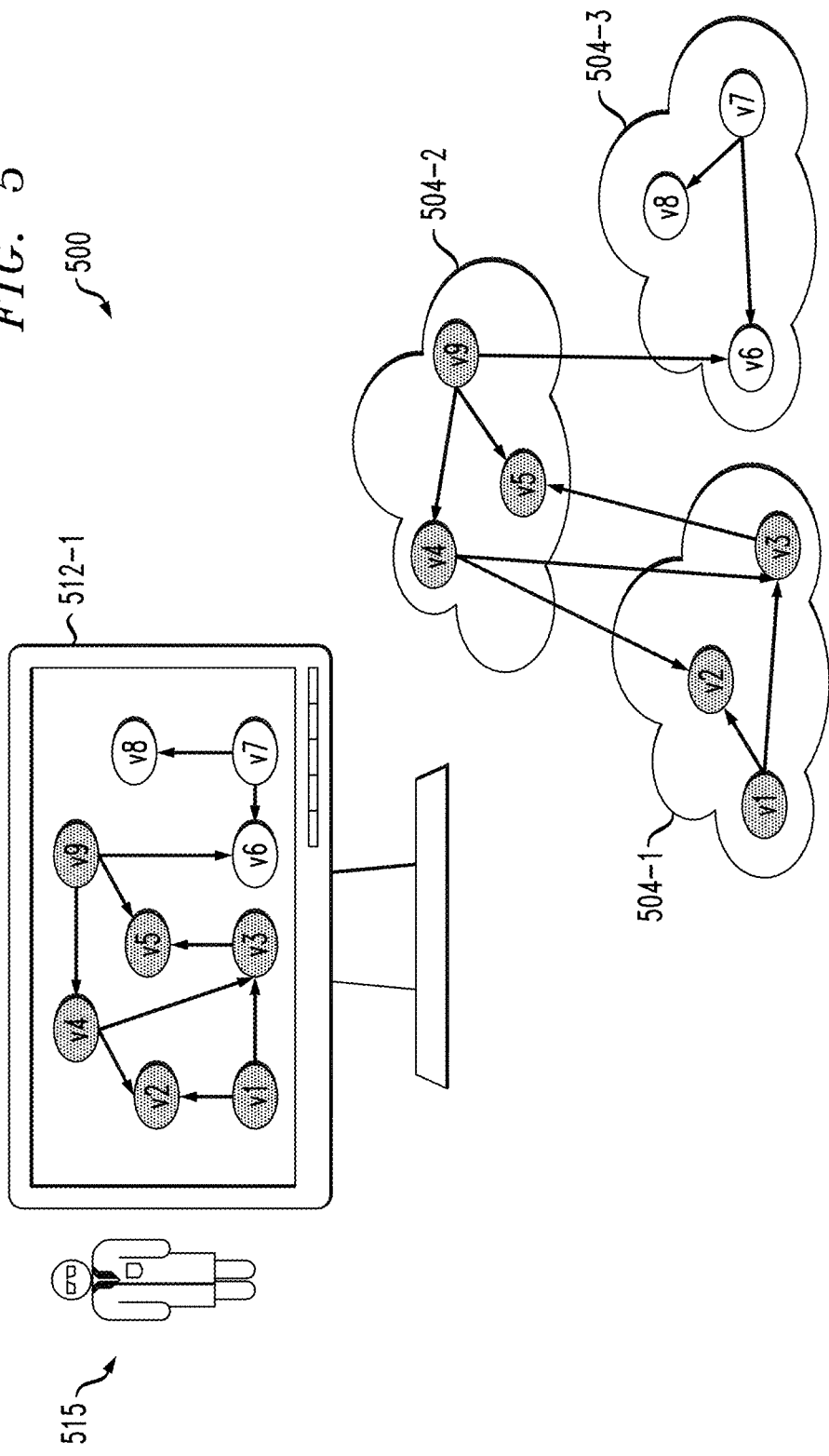

FIG. 6

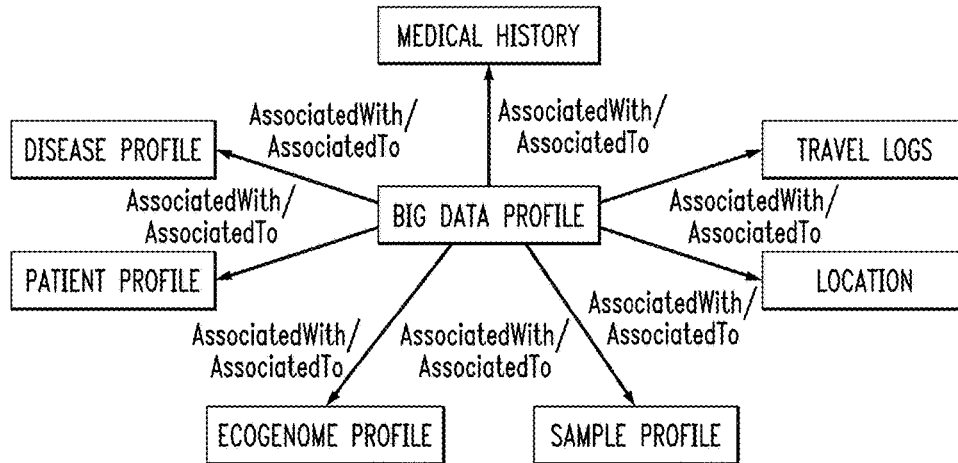

FIG. 7

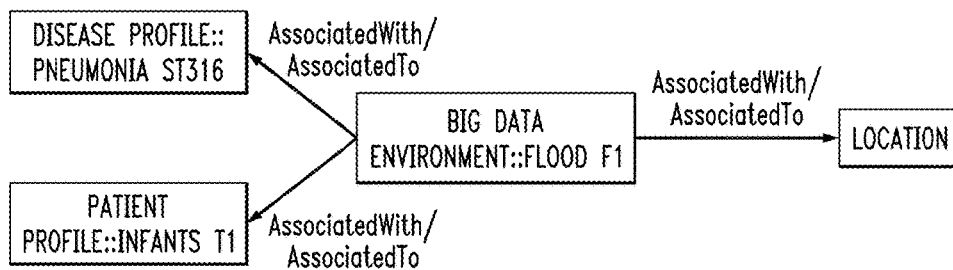

FIG. 8



FIG. 9

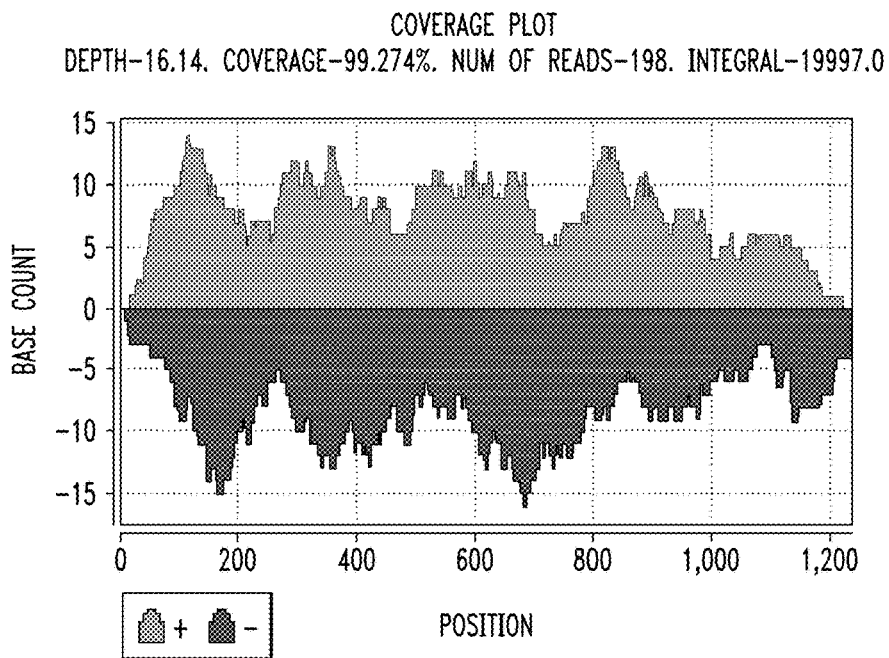

FIG. 10

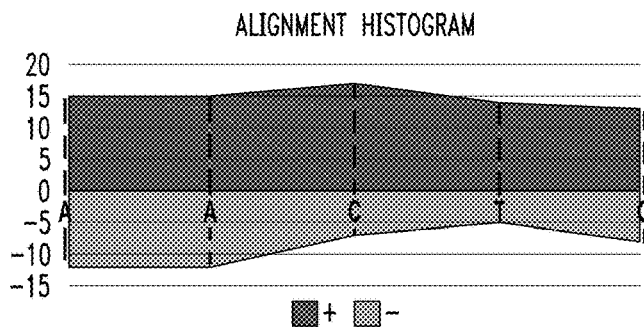

FIG. 11

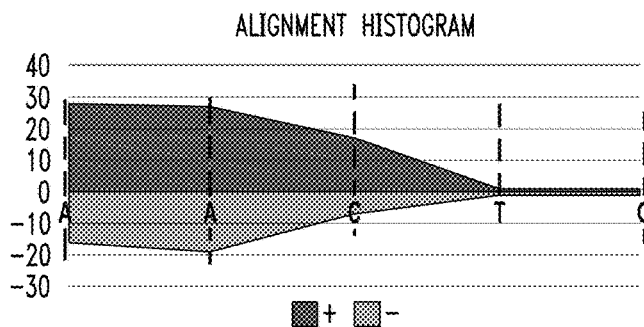

FIG. 12

SAMPLE PROFILE 1

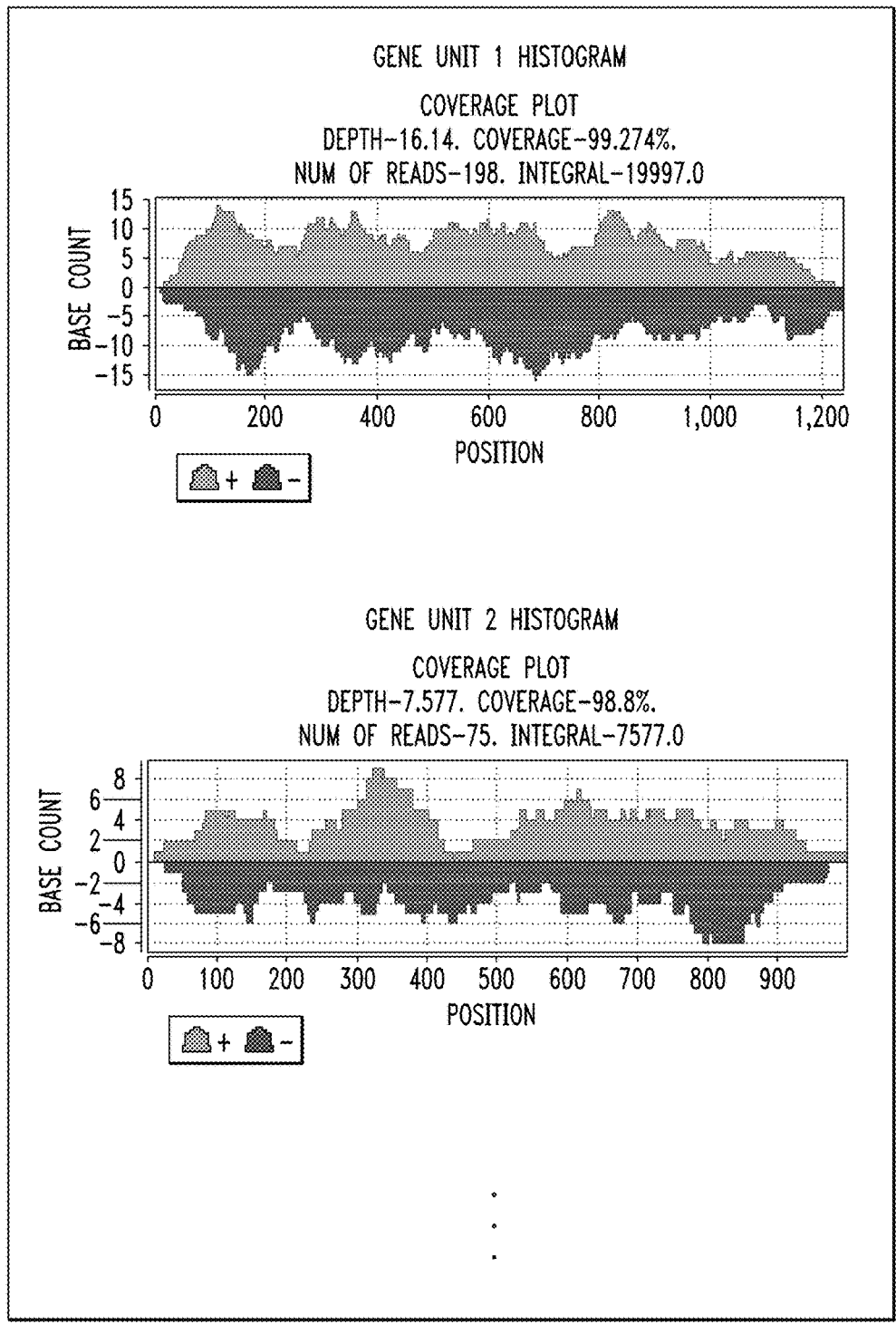

FIG. 14

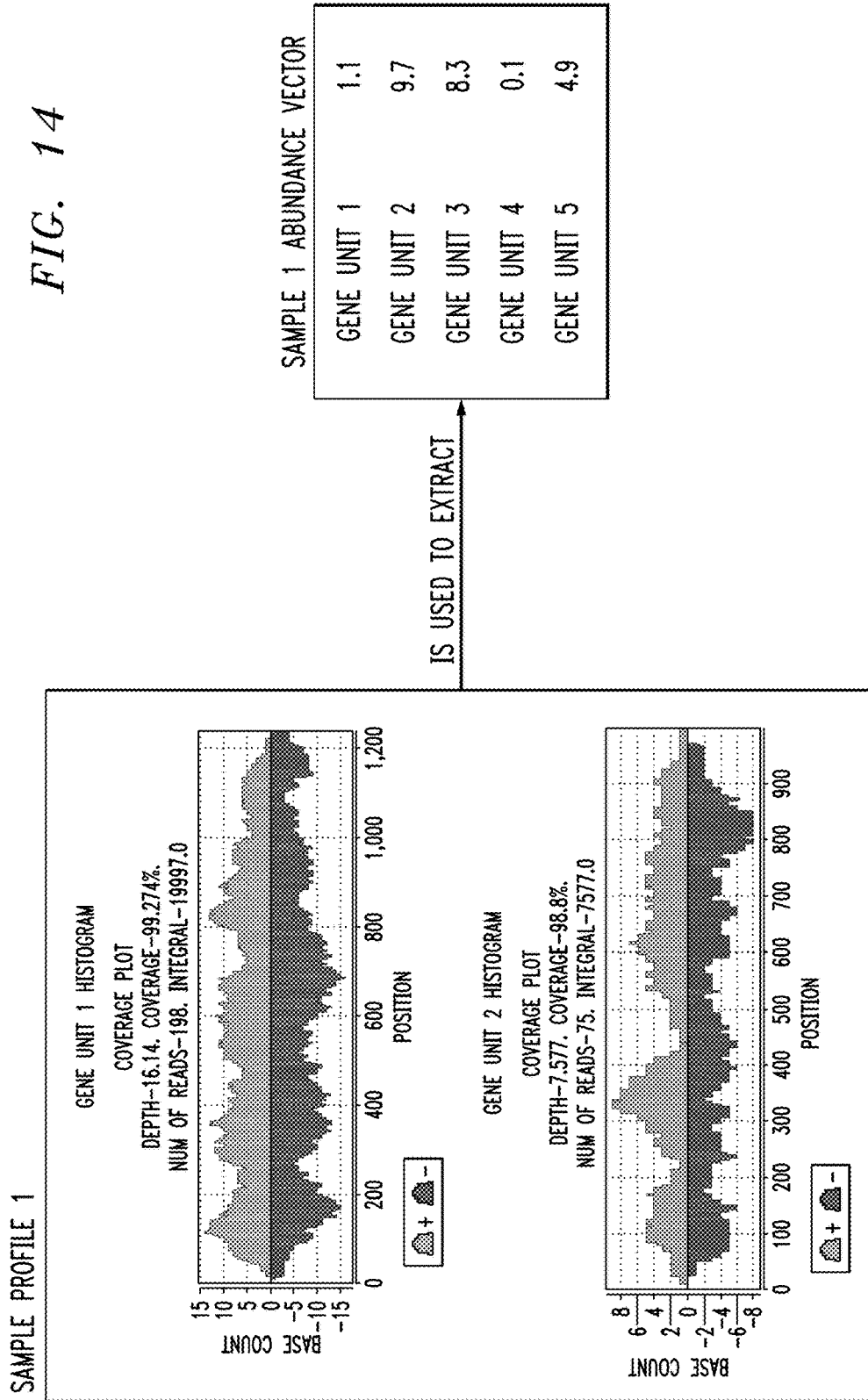

FIG. 15

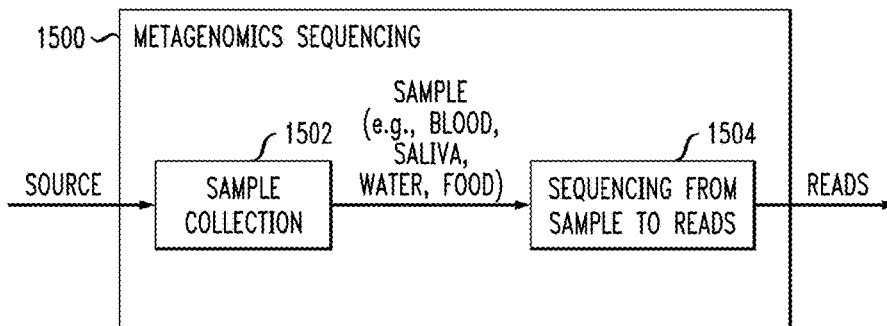
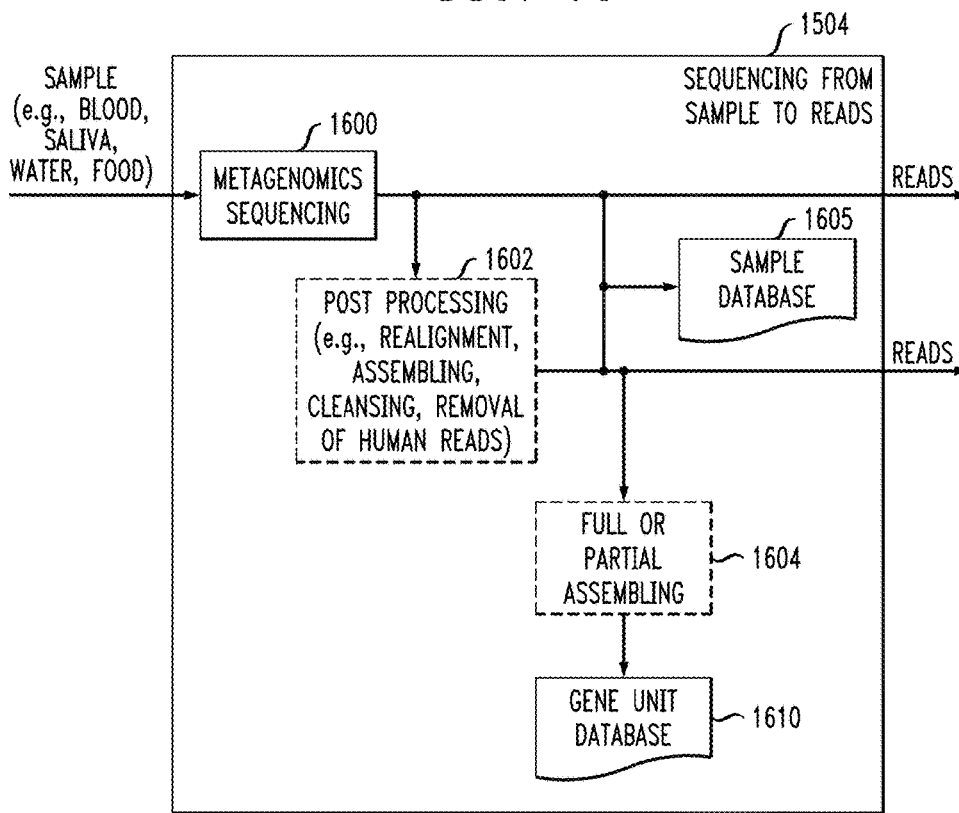
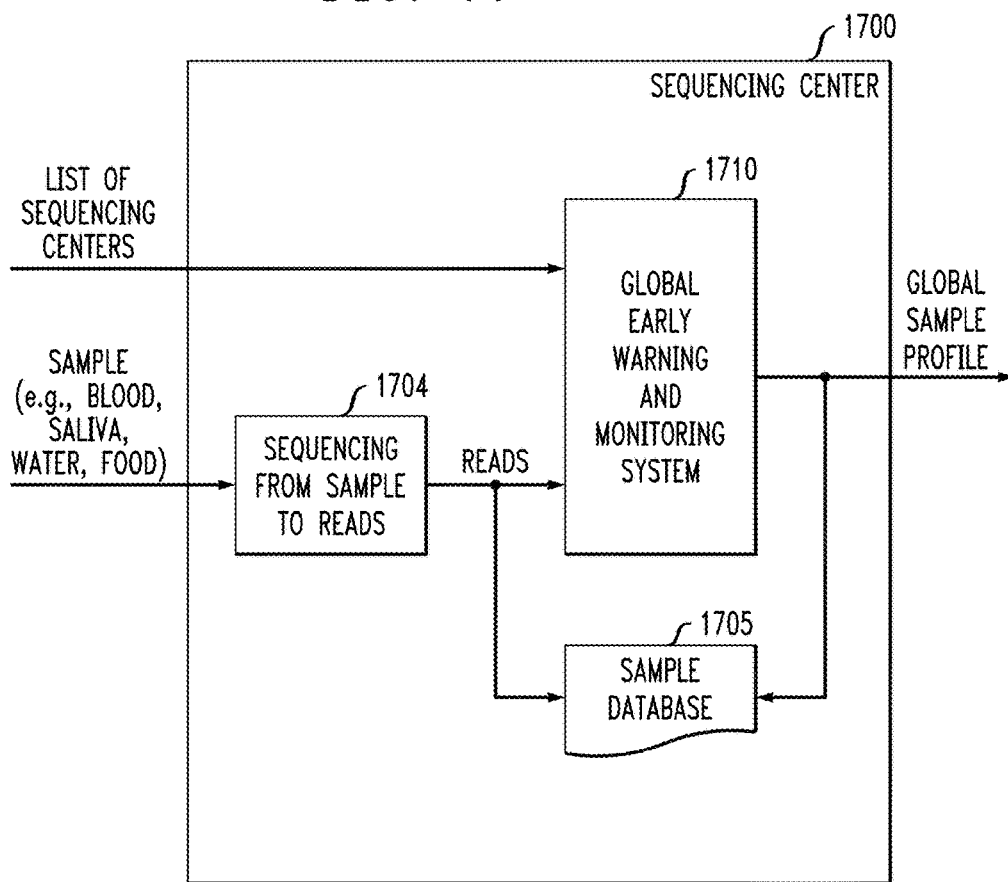

FIG. 16



OPTIONAL

FIG. 17



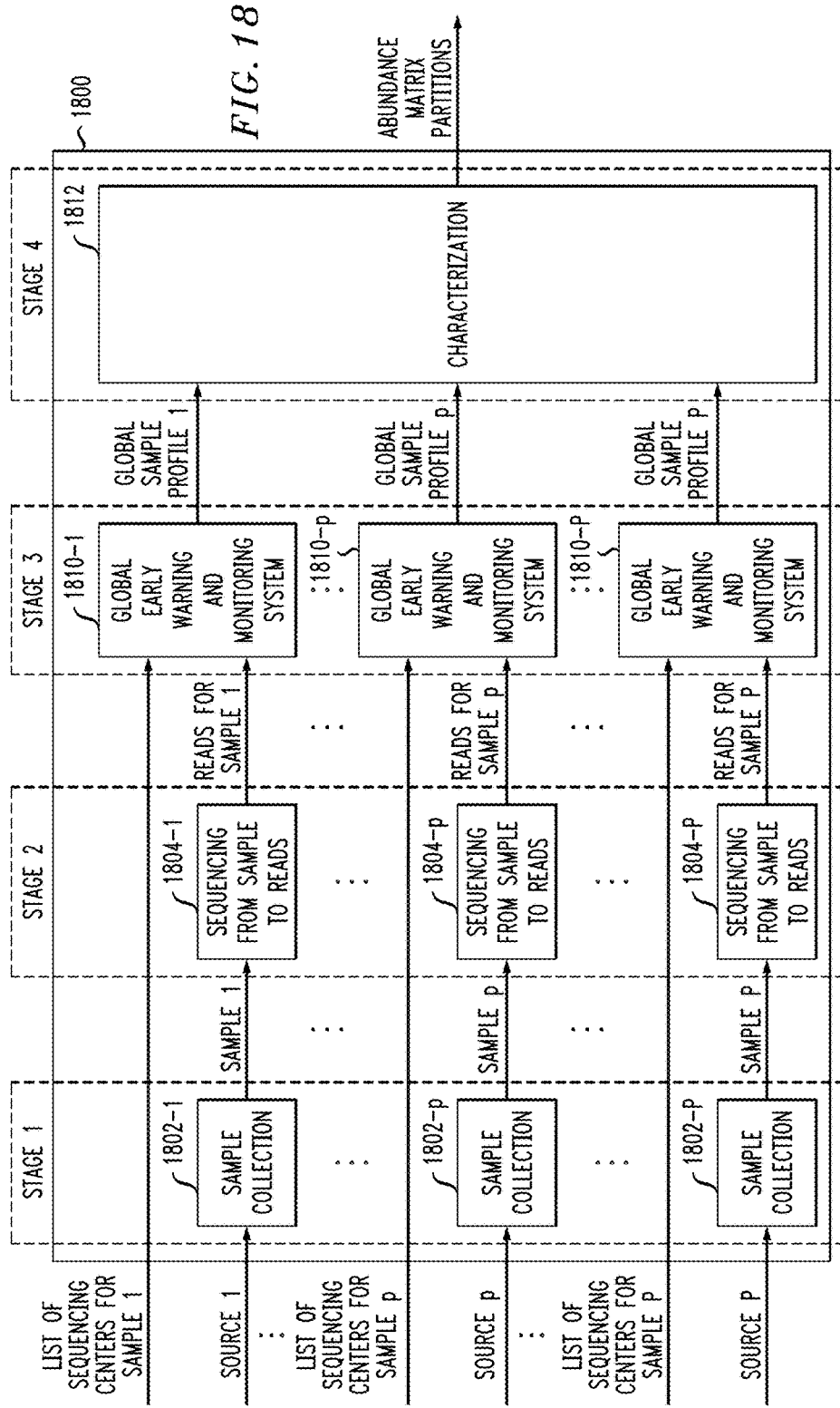

FIG. 19

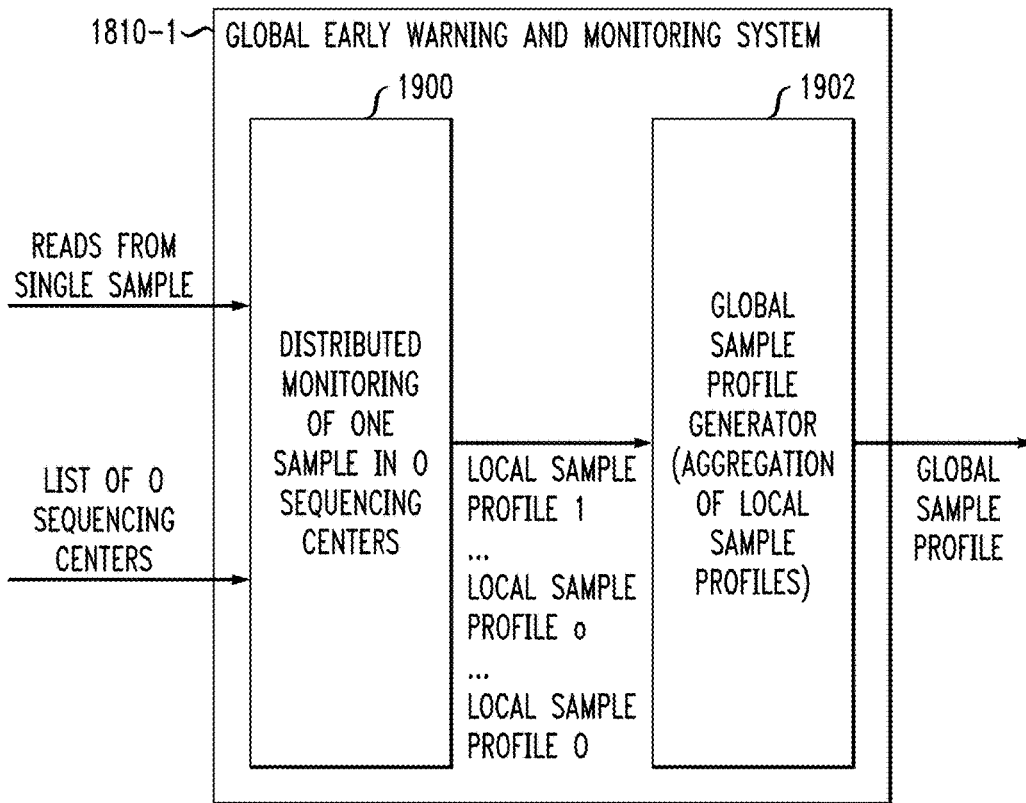

FIG. 20

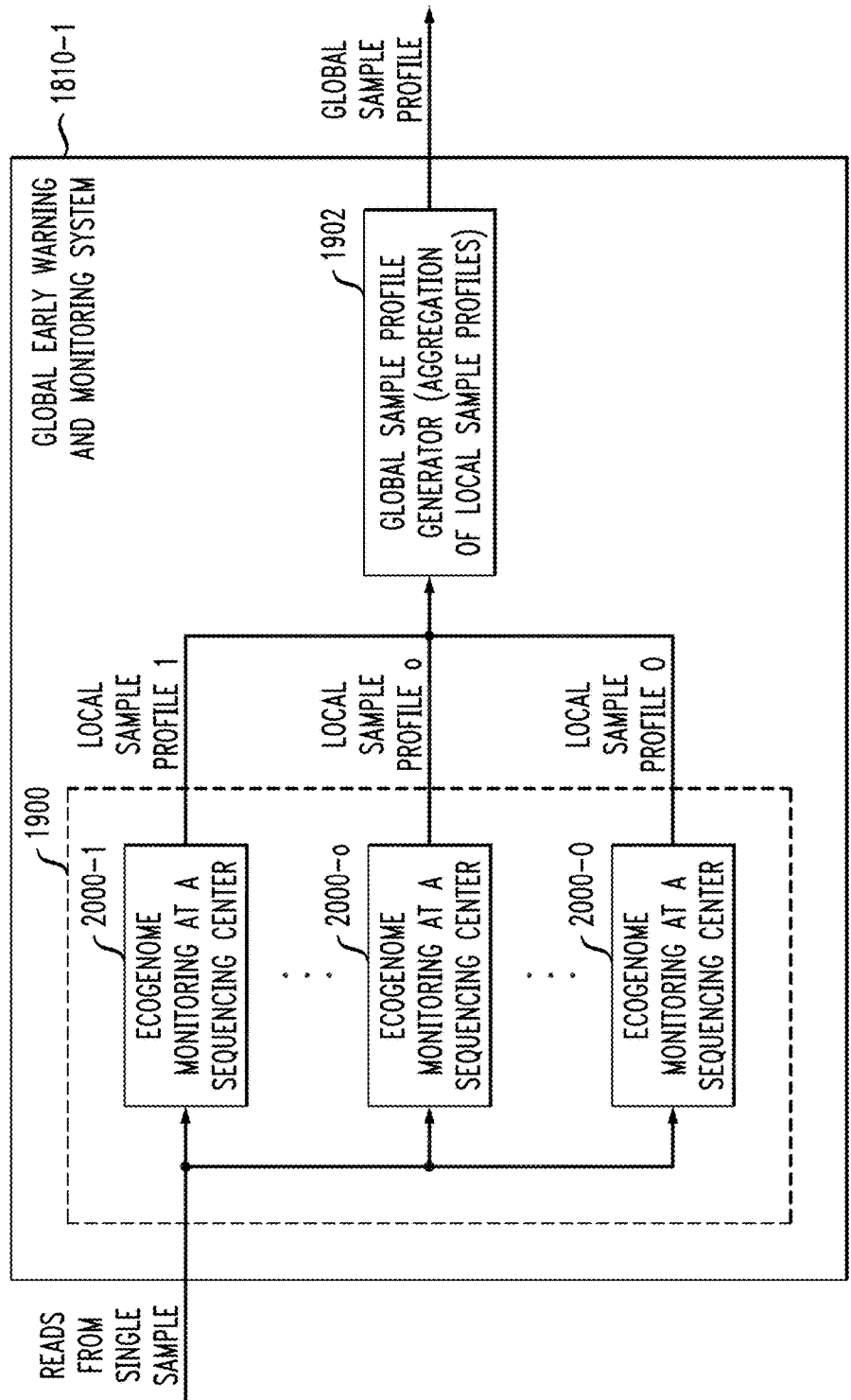

FIG. 21

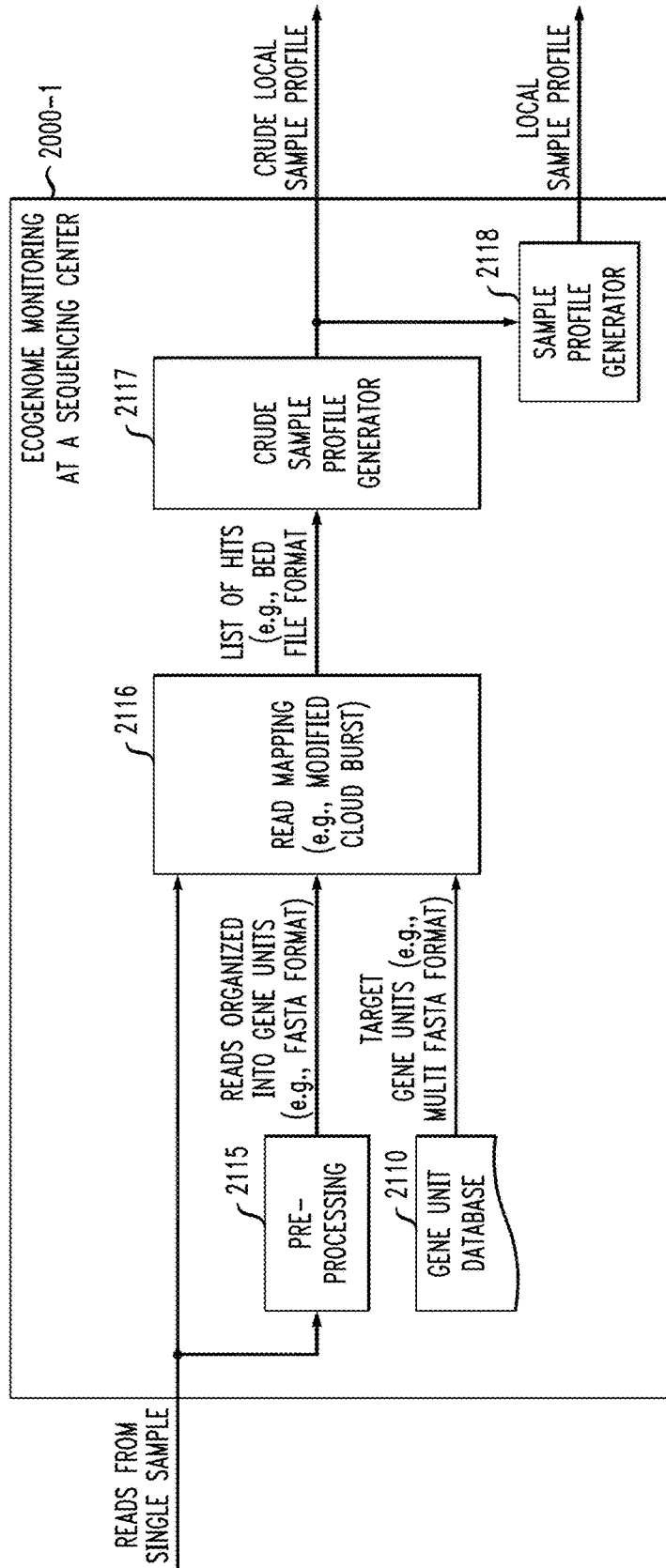
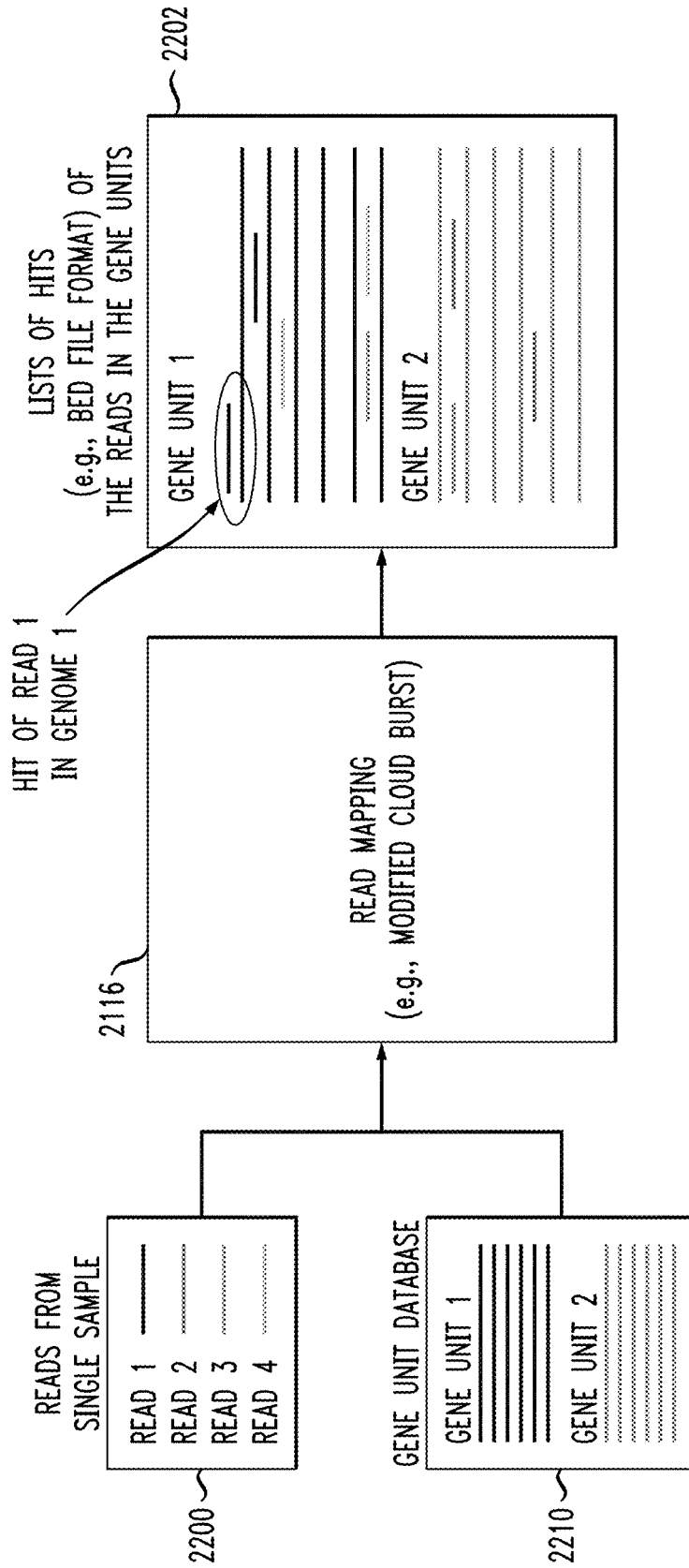

FIG. 22



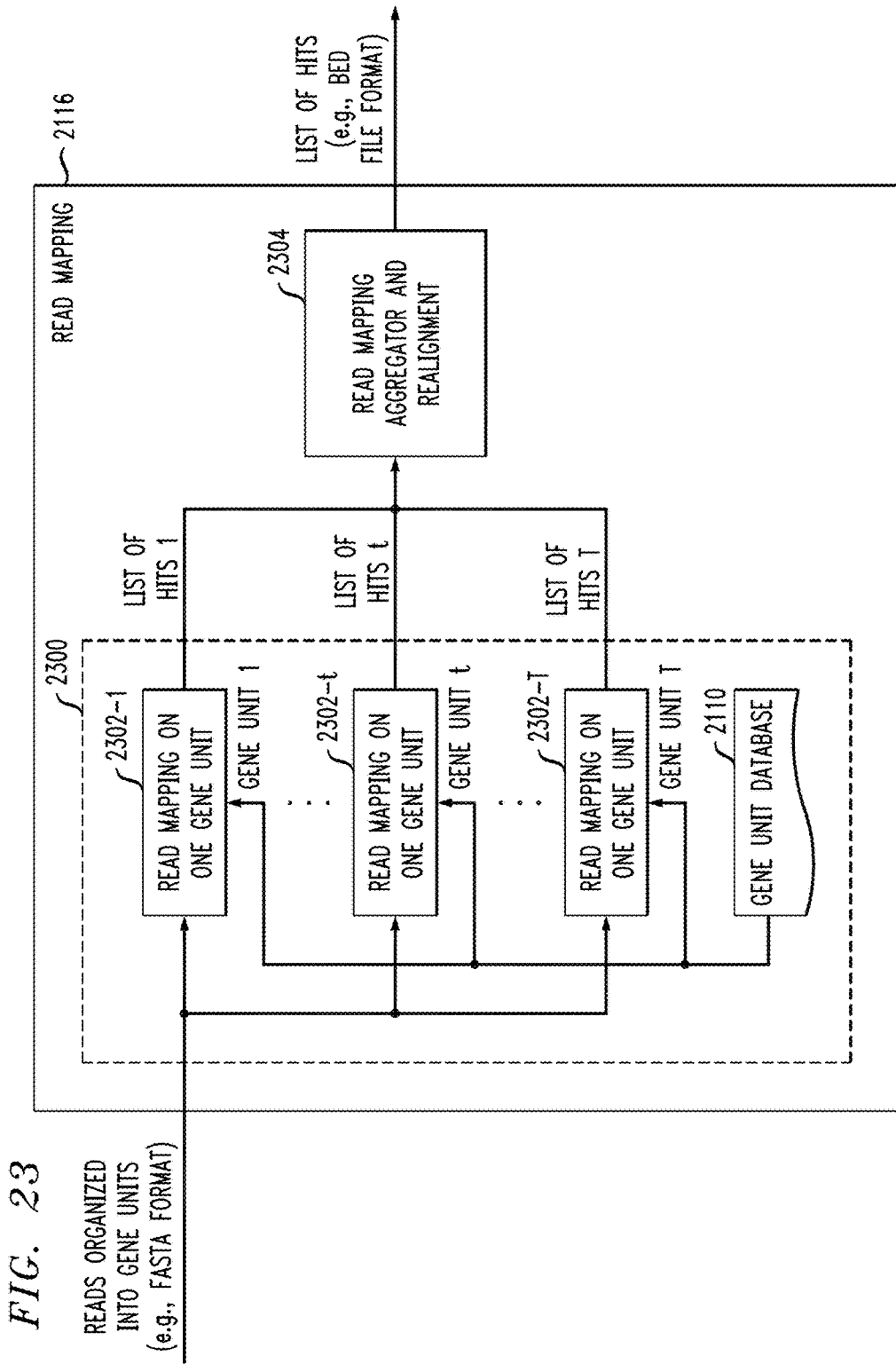

FIG. 24

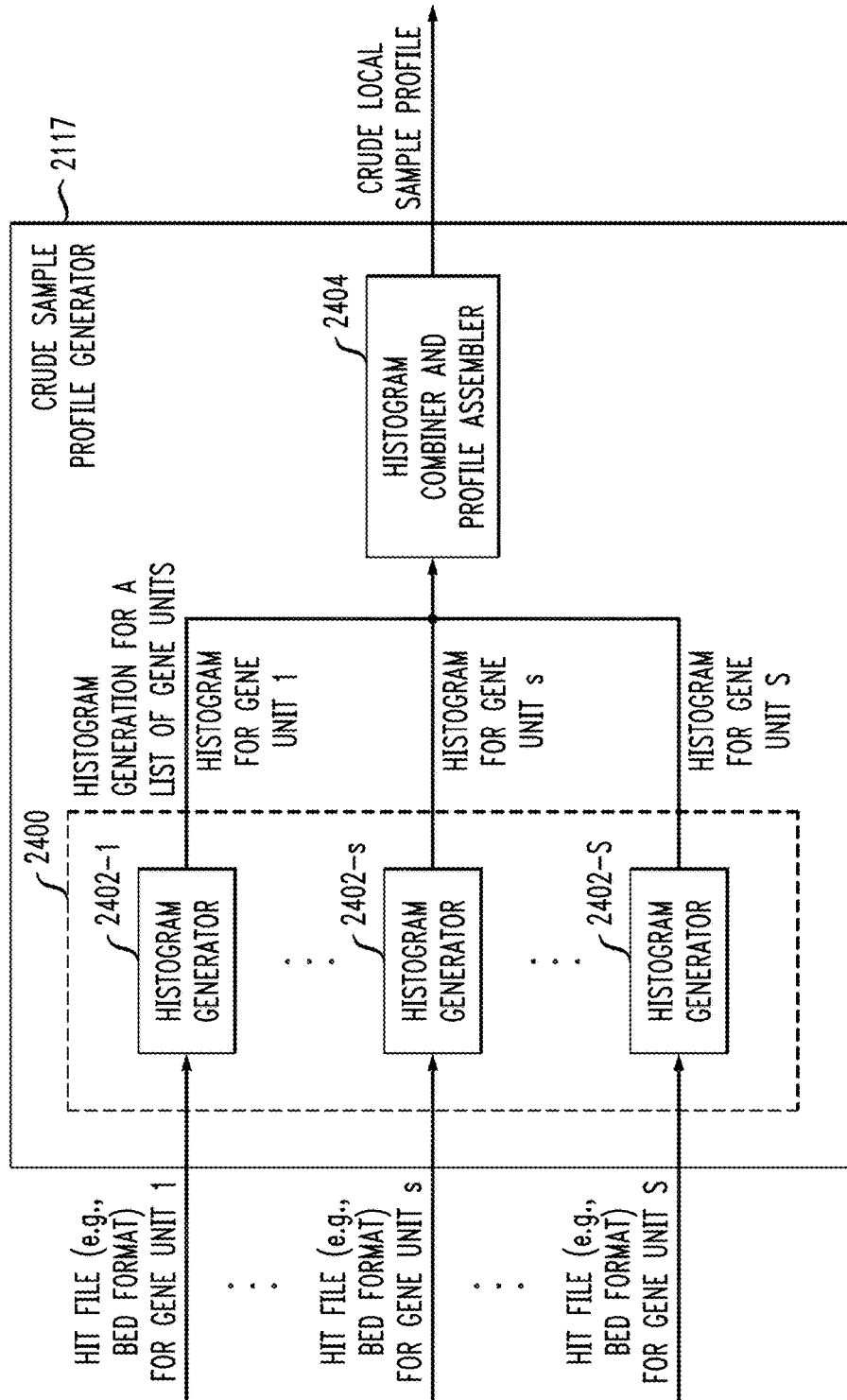

FIG. 25

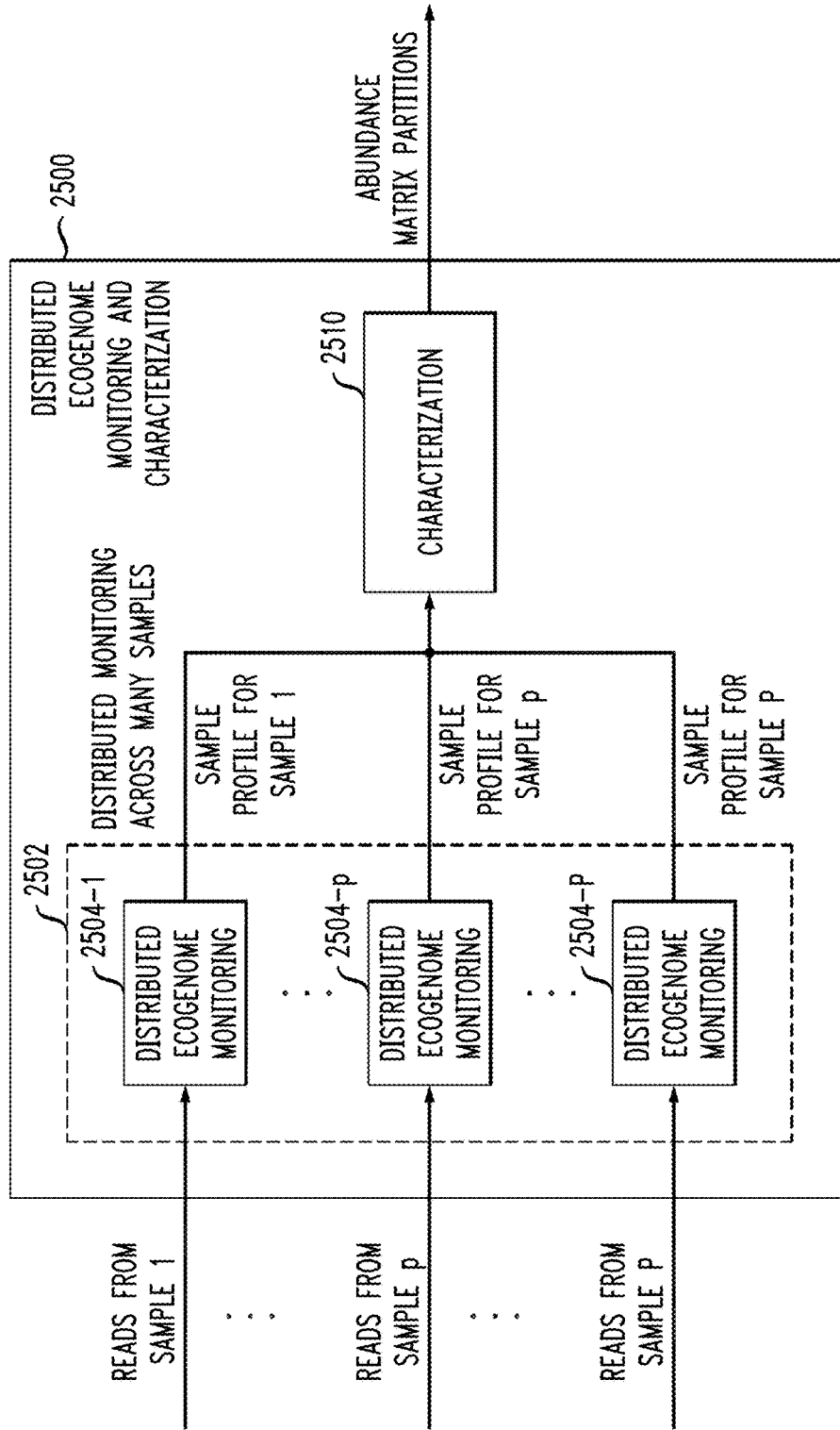

FIG. 26

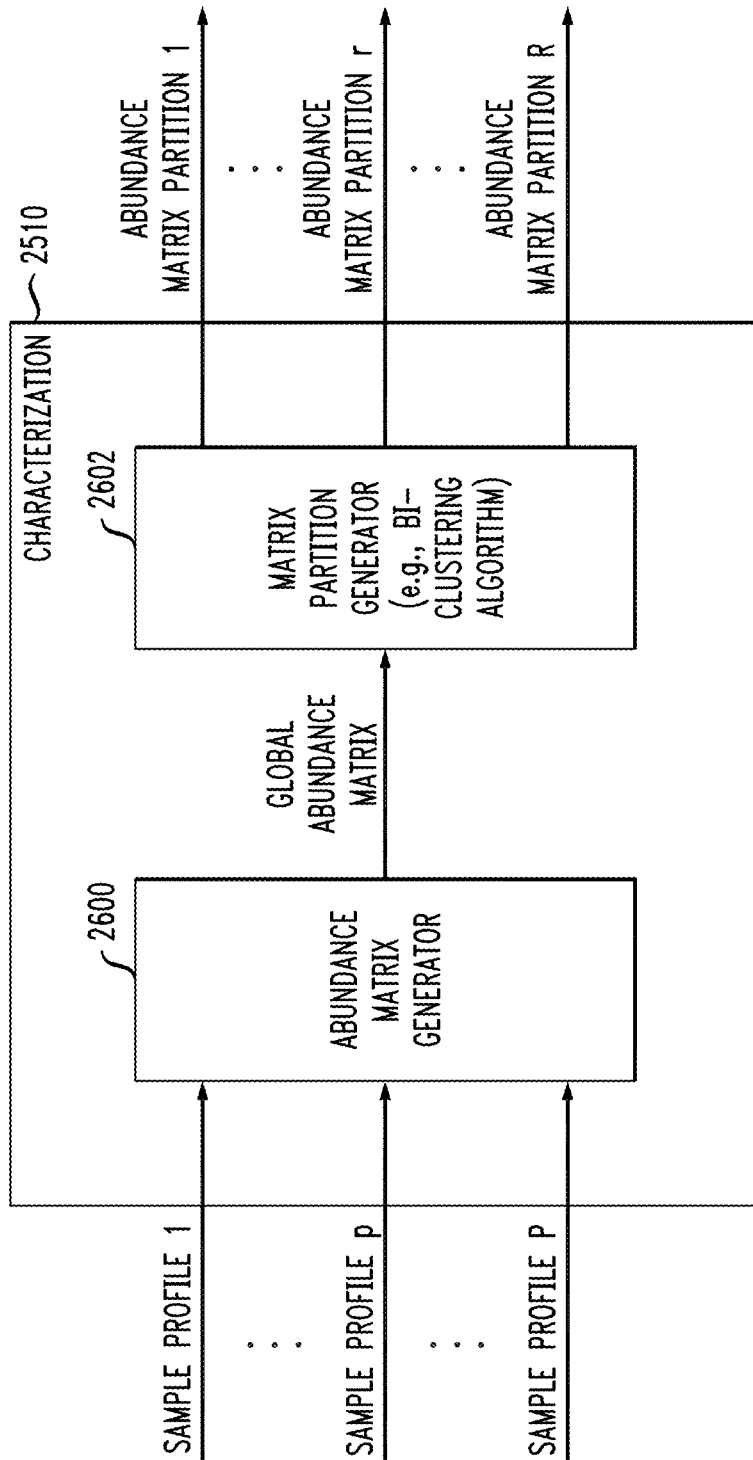

FIG. 27

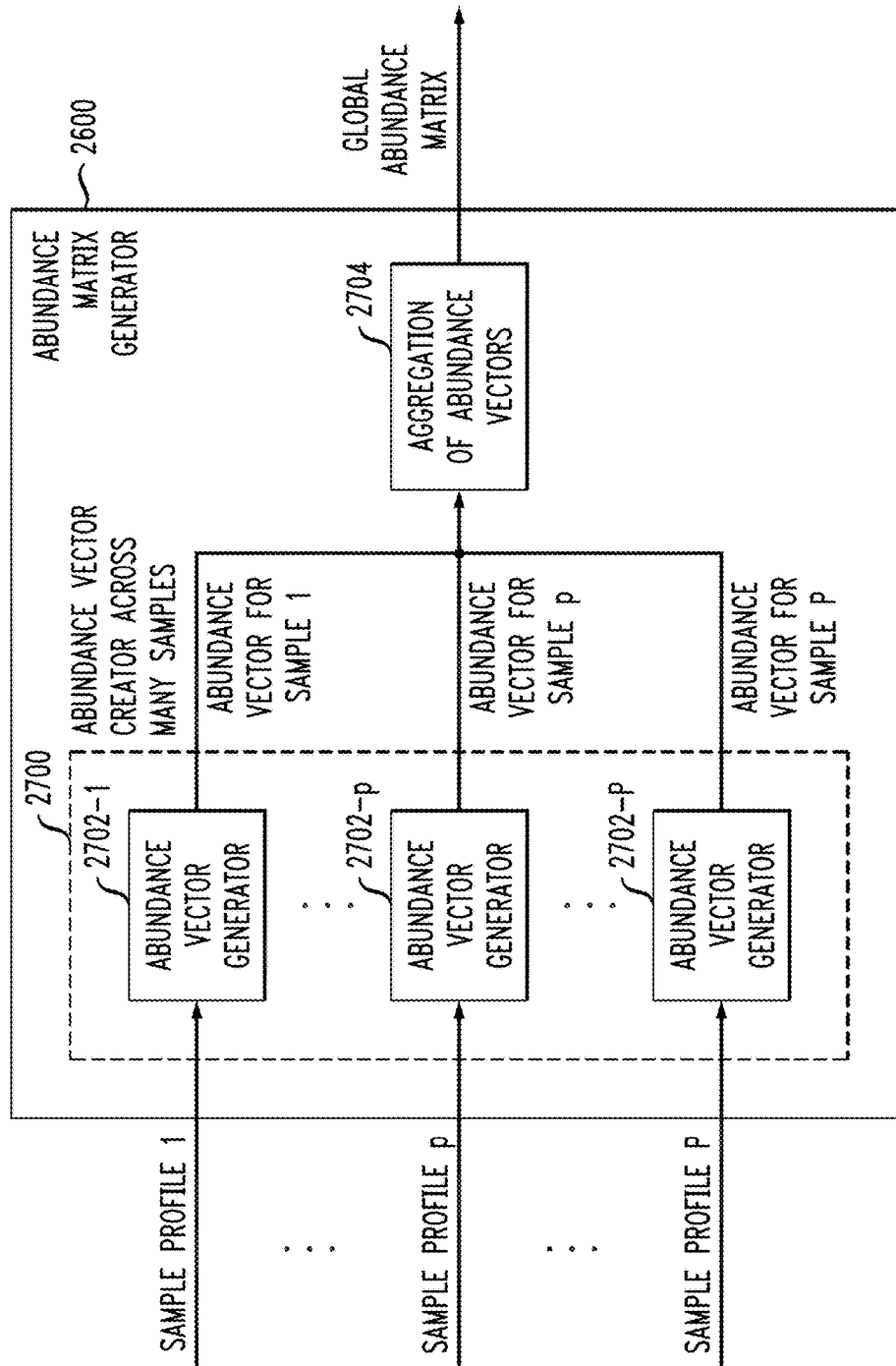

FIG. 28

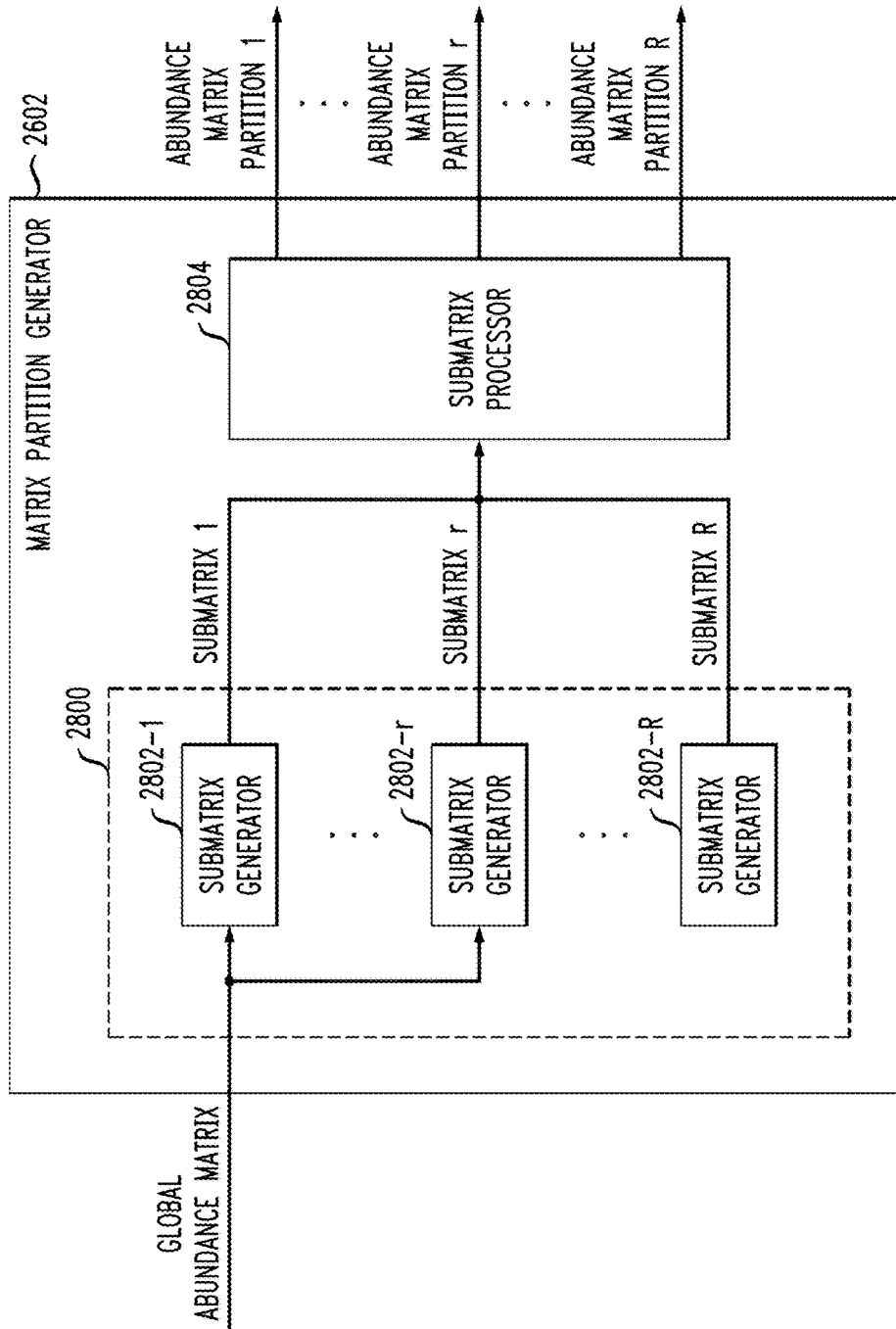

FIG. 29

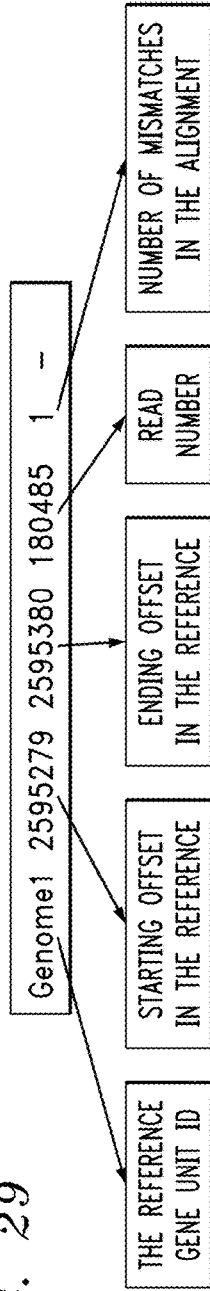
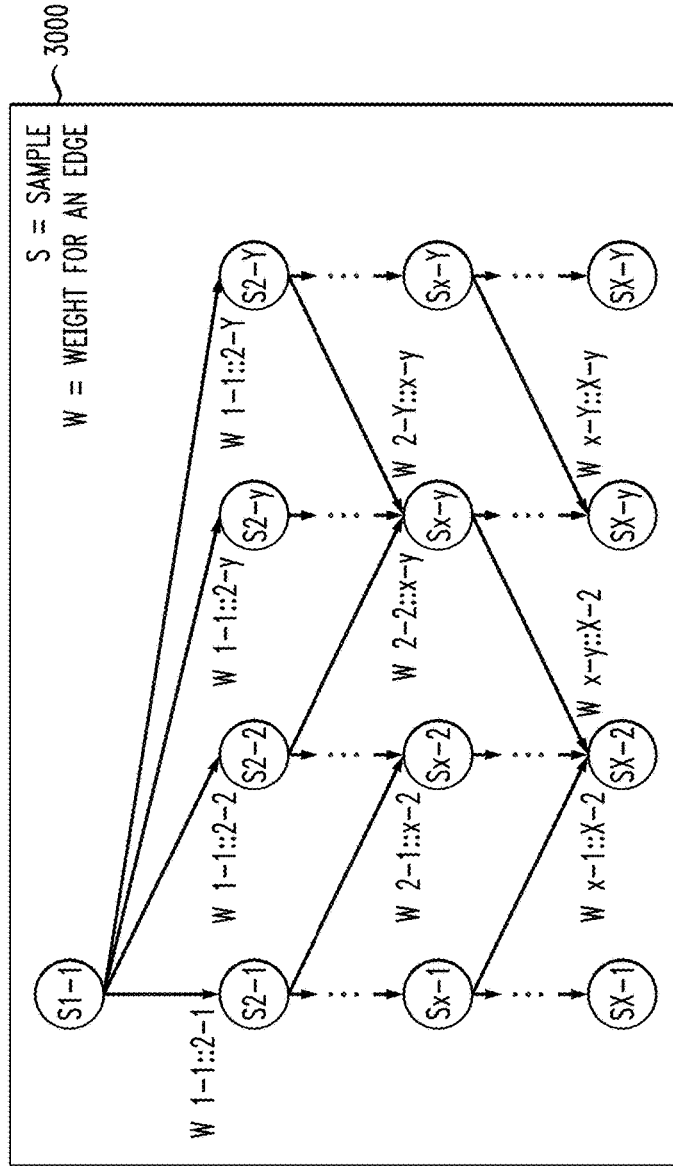

FIG. 30



1

**DISTRIBUTED DATA PROCESSING
PLATFORM FOR METAGENOMIC
MONITORING AND CHARACTERIZATION**

PRIORITY CLAIM

The present application claims priority to U.S. Provisional Patent Application Ser. No. 62/143,404, entitled "World Wide Hadoop Platform," and U.S. Provisional Patent Application Ser. No. 62/143,685, entitled "Bioinformatics," both filed Apr. 6, 2015, and incorporated by reference herein in their entirety.

RELATED APPLICATIONS

The present application is related to the following U.S. Patent Applications, each of which is incorporated by reference herein in its entirety:

Ser. No. 14/983,914, filed Dec. 30, 2015, entitled "Metagenomics-Based Biological Surveillance System using Big Data Profiles,"

Ser. No. 14/983,920, filed Dec. 30, 2015, entitled "Automated Metagenomic Epidemiological Investigation,"

Ser. No. 14/983,932, filed Dec. 30, 2015, entitled "Reasoning on Data Model for Disease Monitoring, Characterization and Investigation,"

Ser. No. 14/983,943, filed Dec. 30, 2015, entitled "Distributed Data Processing Platform for Metagenomic Epidemiological Investigation,"

Ser. No. 14/983,952, filed Dec. 30, 2015, entitled "Distributed Data Processing Platform for Biological Surveillance using Big Data Profiles,"

Ser. No. 14/983,958, filed Dec. 30, 2015, entitled "Metagenomics-Based Biological Surveillance System with Distributed Sequencing Centers,"

Ser. No. 14/983,971, filed Dec. 30, 2015, entitled "Automated Metagenomic Monitoring and Characterization,"

Ser. No. 14/983,981, filed Dec. 30, 2015, entitled "Metagenomics-Based Characterization using Genomic and Epidemiological Comparisons,"

Ser. No. 14/984,004, filed Dec. 30, 2015, entitled "Distributed Data Processing Platform for Biological Surveillance using Genomic and Epidemiological Comparisons,"

Ser. No. 14/982,341, filed Dec. 29, 2015 and entitled "Multi-Cluster Distributed Data Processing Platform,"

Ser. No. 14/982,351, filed Dec. 29, 2015 and entitled "Distributed Catalog Service for Multi-Cluster Data Processing Platform," and

Ser. No. 14/982,355, filed Dec. 29, 2015 and entitled "Beacon-Based Distributed Data Processing Platform."

FIELD

The field relates generally to information processing systems, and more particularly to information processing systems that process data from biological samples and additional or alternative types of related data.

BACKGROUND

Conventional genomics processing is often based on culture-based isolation sequencing in which a biological sample is subject to dilution with a growth medium and then incubated to promote isolation and growth of particular desired cells. The resulting culture is then subject to sequencing which produces a sequencing result comprising genomic reads of only one or more specifically cultured

2

organisms. Such culture-based isolation sequencing is problematic in that not all organisms can be effectively cultured. For example, some organisms may not survive the culture environment, or may be fundamentally altered by the culture environment. As a more particular example of the latter type of problem, culture-based isolation sequencing can in some cases lead to genomic mutation accumulation which alters an original pathogen sequence during culture growth time. Culture-based isolation sequencing also tends to be a lengthy and costly process. Moreover, culture-based isolation sequencing is in many cases performed in geographically-dispersed laboratories or other facilities that do not have adequate accessibility to sequencing results from other similar facilities. It can therefore be very difficult under conventional practice to predict an outbreak of a disease, infection or contamination across different geographic regions.

SUMMARY

Illustrative embodiments of the present invention provide information processing systems that are configured to process biological data derived from metagenomics sequencing of biological samples in multiple distinct data zones, such as different geographic regions. For example, some embodiments provide metagenomics-based biological surveillance systems that can be used to accurately and efficiently predict, detect, track or otherwise characterize an outbreak of a disease, infection or contamination across multiple geographic regions or other types of data zones defined by other types of boundaries. Such arrangements can be advantageously configured to provide metagenomics-based biological surveillance functionality in a decentralized and privacy-preserving manner, so as to overcome the above-noted drawbacks of conventional culture-based isolation sequencing.

In one embodiment, a method comprises configuring a first processing node for communication with one or more additional processing nodes and with one or more of a plurality of geographically-distributed metagenomics sequencing centers via one or more networks, processing metagenomics sequencing results obtained from one or more of the metagenomics sequencing centers in the first processing node, and providing surveillance functionality relating to at least one designated biological issue on behalf of one or more requesting clients based at least in part on the processing of metagenomics sequencing results performed by the first processing node and related processing performed by one or more of the additional processing nodes. Each of the metagenomics sequencing centers in this embodiment is configured to perform metagenomics sequencing on biological samples from respective sample sources in a corresponding data zone.

These and other illustrative embodiments include, without limitation, methods, apparatus, systems, and processor-readable storage media.

BRIEF DESCRIPTION OF THE DRAWINGS

FIG. 1 is a block diagram of an information processing system configured as a metagenomics-based biological surveillance system in an illustrative embodiment of the invention.

FIG. 2 is a flow diagram of an exemplary process implemented in the metagenomics-based biological surveillance system of FIG. 1.

FIG. 3 illustrates distinctions between example metagenomics sequencing used in the metagenomics-based biological surveillance system of FIG. 1 and culture-based isolation sequencing.

FIG. 4 illustrates an example of collective processing of a genomic comparison component and an epidemiologic comparison component to further characterize a disease, infection or contamination.

FIG. 5 illustrates the generation of global view information using metagenomics sequencing results from multiple metagenomics sequencing centers in different geographic regions.

FIGS. 6-8 show examples of relationships between Big Data profiles and associated information elements in illustrative embodiments.

FIGS. 9, 10 and 11 show examples of alignment histograms utilized in metagenomics-based biological surveillance systems in illustrative embodiments.

FIG. 12 shows a sample profile based on multiple alignment histograms in an illustrative embodiment.

FIG. 13 shows one possible file format for a sample profile of the type shown in FIG. 12.

FIG. 14 illustrates generation of a hit abundance score vector for a sample profile of the type shown in FIG. 12.

FIG. 15 illustrates generation of reads from a sample in an illustrative embodiment.

FIG. 16 shows a more detailed view of a sequencing process portion of FIG. 15.

FIG. 17 shows one possible implementation of a sequencing center in an illustrative embodiment.

FIG. 18 shows a multi-stage disease characterization process in an illustrative embodiment.

FIGS. 19 and 20 illustrate aspects of distributed ecogenomic monitoring in respective embodiments.

FIG. 21 illustrates ecogenomic monitoring at one sequencing center for single sample.

FIG. 22 illustrates the mapping of reads from a single sample to hits in multiple gene units.

FIG. 23 illustrates read mapping for reads of one sample against a gene unit database.

FIG. 24 shows one possible implementation of a sample profile generator in a given sequencing center.

FIG. 25 shows another illustrative embodiment of distributed ecogenomic monitoring and characterization.

FIG. 26 shows a more detailed view of a characterization portion of the FIG. 25 embodiment.

FIG. 27 shows a more detailed view of an abundance matrix generator of FIG. 26.

FIG. 28 shows a more detailed view of a matrix partition generator of FIG. 26.

FIG. 29 shows an example file format for read mapping information in one embodiment.

FIG. 30 shows an example of one type of graph for use in conjunction with distributed epidemiological interpretation in an illustrative embodiment.

DETAILED DESCRIPTION

Illustrative embodiments of the present invention will be described herein with reference to exemplary information processing systems and associated computers, servers, storage devices and other processing devices. It is to be appreciated, however, that embodiments of the invention are not restricted to use with the particular illustrative system and device configurations shown. Accordingly, the term “information processing system” as used herein is intended to be broadly construed, so as to encompass, for example, pro-

cessing systems comprising cloud computing and storage systems, as well as other types of processing systems comprising various combinations of physical and virtual processing resources. An information processing system may therefore comprise, for example, a plurality of data centers each comprising one or more clouds hosting multiple tenants that share cloud resources.

FIG. 1 shows an information processing system configured as a metagenomics-based biological surveillance system 100 in an illustrative embodiment. The metagenomics-based biological surveillance system 100 comprises a plurality of processing nodes 102. The processing nodes 102 are arranged in multiple interconnected layers, including a first layer comprising processing nodes individually denoted as 102-1,1 . . . 102-n,1 . . . 102-N,1, a second layer comprising processing nodes individually denoted as 102-1,2 . . . 102-1,2 . . . 102-L,2, and a Z-th layer comprising processing nodes individually denoted as 102-1,Z . . . 102-j,Z . . . 102-J,Z. Accordingly, this arrangement comprises Z layers of processing nodes 102, with the first, second and Z-th layers comprising N, L and J processing nodes, respectively. A wide variety of other arrangements of one or more layers of processing nodes 102 can be used in other embodiments. For example, the processing nodes in some embodiments are arranged in multiple distributed processing node clusters associated with respective distinct geographic regions or other types of data zones.

Each of the processing nodes 102 communicates either directly or via one or more other ones of the processing nodes 102 with one or more metagenomics sequencing centers, individually denoted as 104-1, 104-2, . . . 104-m, . . . 104-M. The processing nodes 102 are configured to communicate with one another and with their associated metagenomics sequencing centers 104 over one or more networks that are not explicitly shown.

Although the FIG. 1 embodiment and other embodiments herein advantageously utilize metagenomics sequencing centers, other embodiments can utilize other types of sequencing centers. Accordingly, embodiments of the invention are not limited to use with metagenomics sequencing. For example, some embodiments can utilize information obtained through culture-based isolation sequencing or other mechanisms, in place of or in addition to information obtained through metagenomics sequencing.

The processing nodes 102 are illustratively implemented as respective worldwide data nodes, and more particularly as respective worldwide Hadoop (WWH) nodes, although numerous alternative processing node types can be used in other embodiments. The WWH nodes are assumed to be configured to perform operations in accordance with any framework supported by an Apache Hadoop YARN (“Yet Another Resource Negotiator”) cluster on one or more corresponding portions of metagenomics sequencing results received from one or more of the metagenomics sequencing centers 104. Examples of frameworks supported by the Hadoop YARN platform include MapReduce, Spark, Hive, MPI and numerous others. Apache Hadoop YARN is also referred to as Hadoop 2.0, and is described in, for example, V. K. Vavilapalli et al., “Apache Hadoop YARN: Yet Another Resource Negotiator,” Proceedings of the 4th Annual Symposium on Cloud Computing, SOCC '13, pp. 5:1-5:16, ACM, New York, N.Y., USA, 2013, which is incorporated by reference herein.

In the FIG. 1 embodiment, the processing nodes 102 may collectively implement a multi-cluster distributed data processing platform. Such a platform may comprise a WWH platform that includes a plurality of potentially geographi-

cally-distributed YARN clusters each comprising a corresponding cluster of distributed data processing nodes. The WWW platform is illustratively configured for worldwide scale, geographically-dispersed computations and other types of cluster-based processing based on locally-accessible data resources.

The acronym WWW as used herein is additionally or alternatively intended to refer to a “worldwide herd” arrangement where the term “herd” in this context illustratively connotes multiple geographically-distributed Hadoop platforms. More generally, WWW is used to denote a worldwide data processing platform potentially comprising multiple clusters.

Additional details regarding WWW platforms that can be used in the FIG. 1 embodiment and other embodiments of the present invention are disclosed in U.S. patent application Ser. No. 14/982,341, filed Dec. 29, 2015 and entitled “Multi-Cluster Distributed Data Processing Platform,” and U.S. patent application Ser. No. 14/982,351, filed Dec. 29, 2015 and entitled “Distributed Catalog Service for Multi-Cluster Data Processing Platform,” both commonly assigned herewith and incorporated by reference herein.

Illustrative embodiments disclosed in these two patent applications provide information processing systems that are configured to execute distributed applications over multiple distributed data processing node clusters associated with respective distinct data zones. Each data zone in a given embodiment illustratively comprises a Hadoop YARN cluster configured to support multiple distributed data processing frameworks, such as MapReduce and Spark. These and other similar arrangements disclosed herein can be advantageously configured to provide analytics functionality in a decentralized and privacy-preserving manner, so as to overcome the above-noted drawbacks of conventional systems. This is achieved in some embodiments by orchestrating execution of distributed applications across the multiple YARN clusters. Computations associated with data available locally within a given YARN cluster are performed within that cluster. Accordingly, instead of moving data from local sites to a centralized site, computations are performed within the local sites where the needed data is available. This provides significant advantages in terms of both performance and privacy. Additional advantages are provided in terms of security, governance, risk and compliance.

In one embodiment, a method comprises initiating a first application in a first one of a plurality of distributed processing node clusters associated with respective data zones, each of the clusters being configured to perform processing operations utilizing local data resources locally accessible within its corresponding data zone, and determining a plurality of data resources to be utilized by the application. The method further includes identifying for each of the plurality of data resources to be utilized by the application whether the data resource is a local data resource that is locally accessible within the data zone of the first distributed processing node cluster or a remote data resource that is not locally accessible within the data zone of the first distributed processing node cluster.

For one or more of the plurality of data resources that are identified as local data resources, processing operations are performed utilizing the local data resources in the first cluster in accordance with the first application.

For one or more of the plurality of data resources that are identified as remote data resources, respective additional applications are initiated in one or more additional ones of the plurality of distributed processing node clusters and processing operations are performed utilizing the remote

data resources in the corresponding one or more additional clusters in accordance with the one or more additional applications.

The process is repeated recursively for each additional application until all processing required by the first application is complete.

Processing results from the first cluster and the one or more additional clusters are aggregated and the aggregated processing results are provided to a client.

In another embodiment, a method comprises implementing a first portion of a distributed catalog service for a given one of a plurality of distributed processing node clusters associated with respective data zones, each of the clusters being configured to perform processing operations utilizing local data resources locally accessible within its corresponding data zone. The method further comprises receiving in the first portion of the distributed catalog service a request to identify for each of a plurality of data resources to be utilized by an application initiated in the given cluster whether the data resource is a local data resource or a remote data resource relative to the given cluster, and providing from the first portion of the distributed catalog service a response to the request. The first portion of the distributed catalog service in combination with additional portions implemented for respective additional ones of the plurality of distributed processing node clusters collectively provide the distributed catalog service with capability to resolve local or remote status of data resources in the data zones of each of the clusters responsive to requests from any other one of the clusters.

It is to be appreciated that a wide variety of other types of processing nodes **102** can be used in other embodiments. Accordingly, the use of WWW nodes in the FIG. 1 embodiment and other embodiments disclosed herein is by way of illustrative example only, and should not be construed as limiting in any way.

For example, additional or alternative types of processing node functionality that may be incorporated in at least a subset of the processing nodes of an information processing system in illustrative embodiments are described in U.S. Pat. No. 9,020,802, entitled “Worldwide Distributed Architecture Model and Management,” and U.S. Pat. No. 9,158,843, entitled “Addressing Mechanism for Data at World Wide Scale,” which are commonly assigned herewith and incorporated by reference herein.

Each of the metagenomics sequencing centers **104** in the system **100** is associated with a corresponding set of sample sources **110**, individually denoted as sample source sets **110-1**, **110-2**, . . . **110-m**, . . . **110-M**. The sample sources each provide one or more biological samples to the corresponding metagenomics sequencing center for metagenomics sequencing. Results of the metagenomics sequencing performed on a given biological sample are illustratively provided by the metagenomics sequencing center to an associated one of the processing nodes **102** for additional processing associated with provision of biological surveillance functionality within the system **100**.

The sample sources of each of the sets **110** of sample sources are individually identified using the letter S in FIG. 1. Although these sample sources are illustratively shown as being external to the metagenomics sequencing centers **104**, this is by way of example only and it is assumed in some embodiments that at least a subset of the sample sources of a given set **110** are within the corresponding metagenomics sequencing center **104**. Accordingly, a given metagenomics

sequencing center can perform metagenomics sequencing operations using a combination of internal and external local sample sources.

The results of the metagenomics sequencing performed by a given one of the metagenomics sequencing centers **104** illustratively comprise results of reading the genomic material of one or more organisms in each of a plurality of biological samples obtained from corresponding ones of the sample sources **110**. For example, the genetic material of a particular organism in a biological sample may comprise billions of base pairs. This genetic material may therefore be separated into readable chunks each of about 50 to 1000 base pairs in length. Such readable chunks are examples of what are more generally referred to as “reads” of a given biological sample. The biological sample can comprise a single organism or multiple organisms within a given environment from which the sample is taken. For example, a biological sample may be taken from a patient.

It should be understood that the above-noted reads are merely examples of what are more generally referred to herein as “metagenomics sequencing results.” Such results can take different forms in different embodiments, as will be readily appreciated by those skilled in the art. For example, such metagenomics sequencing results can comprise reads that have been processed in a variety of different ways within a metagenomics sequencing center before being provided to one of more of the processing nodes **102** for additional processing. Numerous other types of metagenomics sequencing results can be used in other embodiments.

In some embodiments, the reads of biological samples are subject to mapping operations in the processing nodes **102** or the metagenomics sequencing centers **104**. For example, one or more reads of a given biological sample may be subject to mapping based on string resemblance to target genomic sequences. Such a mapping arrangement is illustratively used to generate what is referred to herein as a hit abundance score vector for the given biological sample. Multiple such hit abundance score vectors generated for different biological samples are combined into a hit abundance score matrix that is processed by multiple ones of the processing nodes **102** in characterizing a disease, infection or contamination, or otherwise providing metagenomics-based biological surveillance functionality within the system **100**, as will be described in more detail below.

Each of the processing nodes **102** is coupled directly or indirectly via one or more other ones of the processing nodes **102** to one or more clients **112**. By way of example, the set of clients **112** may include one or more desktop computers, laptop computers, tablet computers, mobile telephones or other types of communication devices or other processing devices in any combination. The clients are individually denoted in the figure as clients **112-1**, **112-2**, **112-3**, . . . **112-k**, . . . **112-K**.

The variables J, K, L, M, N and Z used in FIG. 1 denote arbitrary values, as embodiments of the invention can be configured using any desired number of processing nodes **102**, processing node layers, metagenomics sequencing centers **104** and clients **112**. For example, some embodiments may include multiple metagenomics sequencing centers **104** and multiple clients **112** but only a single processing node **102**, or multiple processing nodes **102** and clients **112** but only a single metagenomics sequencing center **104**. Numerous alternative arrangements are possible, including embodiments in which a single system element combines functionality of at least a portion of a processing node and functionality of at least a portion of a metagenomics sequencing center. Thus, alternative embodiments in which

the functions of a WWH node and a metagenomics sequencing center are at least partially combined into a common processing entity are possible.

The processing nodes **102** in some embodiments are implemented at least in part as respective analysis nodes. The analysis nodes may comprise respective computers in a cluster of computers associated with a supercomputer or other high performance computing (HPC) system. The term “processing node” as used herein is intended to be broadly construed, and such nodes in some embodiments may comprise respective compute nodes in addition to or in place of providing analysis node functionality.

The system **100** may include additional nodes that are not explicitly shown in the figure. For example, the system **100** may comprise one or more name nodes. Such name nodes may comprise respective name nodes of a Hadoop Distributed File System (HDFS), although other types of name nodes can be used in other embodiments. Particular objects or other stored data of a storage platform can be made accessible to one or more of the processing nodes **102** via a corresponding name node. For example, such name nodes can be utilized to allow the processing nodes **102** to address multiple HDFS namespaces within the system **100**.

Each of the processing nodes **102** and metagenomics sequencing centers **104** is assumed to comprise one or more databases for storing metagenomics sequencing results and additional or alternative types of data.

Databases associated with the processing nodes **102** or the metagenomics sequencing centers **104** and possibly other elements of the system **100** can be implemented using one or more storage platforms. For example, a given storage platform can comprise any of a variety of different types of storage including network-attached storage (NAS), storage area networks (SANs), direct-attached storage (DAS), distributed DAS and software-defined storage (SDS), as well as combinations of these and other storage types.

A given storage platform may comprise storage arrays such as VNX® and Symmetrix VIVIX® storage arrays, both commercially available from EMC Corporation. Other types of storage products that can be used in implementing a given storage platform in an illustrative embodiment include software-defined storage products such as ScaleIO™ and ViPR®, server-based flash storage devices such as DSSD™, cloud storage products such as Elastic Cloud Storage (ECS), object-based storage products such as Atmos, scale-out all-flash storage arrays such as XtremIO™, and scale-out NAS clusters comprising Isilon® platform nodes and associated accelerators in the S-Series, X-Series and NL-Series product lines, all from EMC Corporation. Combinations of multiple ones of these and other storage products can also be used in implementing a given storage platform in an illustrative embodiment.

Additionally or alternatively, a given storage platform can implement multiple storage tiers. For example, a storage platform can comprise a 2 TIERS™ storage system from EMC Corporation.

These and other storage platforms can be part of what is more generally referred to herein as a processing platform comprising one or more processing devices each comprising a processor coupled to a memory.

A given processing device may be implemented at least in part utilizing one or more virtual machines or other types of virtualization infrastructure such as Docker containers or other types of Linux containers (LXCs). The processing nodes **102** and metagenomics sequencing centers **104**, as

well as other system components, may be implemented at least in part using processing devices of such processing platforms.

Communications between the various elements of system **100** may take place over one or more networks. These networks can illustratively include, for example, a global computer network such as the Internet, a wide area network (WAN), a local area network (LAN), a satellite network, a telephone or cable network, a cellular network, a wireless network implemented using a wireless protocol such as WiFi or WiMAX, or various portions or combinations of these and other types of communication networks.

As a more particular example, some embodiments may utilize one or more high-speed local networks in which associated processing devices communicate with one another utilizing Peripheral Component Interconnect express (PCIe) cards of those devices, and networking protocols such as InfiniBand, Gigabit Ethernet or Fibre Channel. Numerous alternative networking arrangements are possible in a given embodiment, as will be appreciated by those skilled in the art.

It is to be appreciated that the particular arrangement of system elements shown in FIG. **1** is for purposes of illustration only, and that other arrangements of additional or alternative elements can be used in other embodiments. For example, numerous alternative system configurations can be used to implement metagenomics-based surveillance functionality as disclosed herein.

The operation of the system **100** will now be described in further detail with reference to the flow diagram of FIG. **2**. The process as shown includes steps **200** through **204**, and is suitable for use in the system **100** but is more generally applicable to other types of metagenomics-based biological surveillance systems.

In step **200**, a first processing node is configured for communication with one or more additional processing nodes and with one or more of a plurality of geographically-distributed metagenomics sequencing centers via one or more networks. Each of the metagenomics sequencing centers is assumed to be configured to perform metagenomics sequencing on biological samples from respective sample sources in a corresponding data zone. In the context of the FIG. **1** embodiment, a first one of the WWH nodes **102** is configured for communication with one or more additional ones of the WWH nodes **102** and with one or more of the metagenomics sequencing centers **104**. Each of the metagenomics sequencing centers **104** is configured to perform metagenomics sequencing on biological samples from its corresponding locally-accessible one of the sets **110** of sample sources. The sample sources providing the biological samples that are processed in the metagenomics sequencing centers illustratively comprise one or more of water sources, food sources, agricultural sources and clinical sources, as well as additional or alternative sources, in any combination.

In step **202**, metagenomics sequencing results obtained from one or more of the metagenomics sequencing centers are processed in the first processing node. Again, in the context of the FIG. **1** embodiment, a given one of the WWH nodes **102** can process metagenomics sequencing results from one or more of the metagenomics sequencing centers **104**. The processing of the metagenomics sequencing results in the given WWH node may comprise, for example, determining if genomic material in the metagenomics sequencing results is present in one or more known genomes.

The given WWH node and at least a subset of the remaining WWH nodes **102** can collectively form multiple YARN clusters with each such cluster being associated with

a corresponding one of the metagenomics sequencing centers **104**. Each of the WWH nodes **102** in such an arrangement is configured to perform operations in accordance with at least one supported framework of its YARN cluster on one or more corresponding portions of the metagenomics sequencing results.

The metagenomics sequencing results for a given one of the biological samples may comprise a complete sequencing of the biological sample performed without utilization of a culture-based pathogen isolation process. The complete sequencing in such an arrangement may comprise a set of reads for all organisms in the sample. Alternatively, the metagenomics sequencing results for a given one of the biological samples may comprise a subset of reads for the given biological sample that are determined to match existing reads from other samples. In some embodiments, the metagenomics sequencing results for a given one of the biological samples may comprise a subset of reads for the given biological sample that excludes any reads that match a human genome.

The processing of the metagenomics sequencing results may illustratively comprise generating a hit abundance score vector for a given one of the biological samples, with the hit abundance score vector comprising a plurality of entries corresponding to respective occurrence frequencies of at least one read of the given biological sample in respective target genomic sequences.

In some embodiments, the entries of the hit abundance score vector generated for the given one of the biological samples may each be normalized based at least in part on a length of the corresponding one of the target genomic sequences.

Additionally or alternatively, the occurrence frequency in a given one of the entries of the hit abundance score vector generated for the given one of the biological samples may comprise a cumulative occurrence frequency comprising a combination of respective individual occurrence frequencies for respective ones of a plurality of individual reads of the given biological sample in a corresponding one of the target genomic sequences. The plurality of individual reads may exclude reads associated with one or more host genomic sequences.

In step **204**, surveillance functionality relating to at least one designated biological issue is provided on behalf of one or more requesting clients based at least in part on the processing of metagenomics sequencing results performed by the first processing node and related processing performed by one or more of the additional processing nodes. For example, with reference to the FIG. **1** embodiment, a given one of the WWH nodes **102** can provide surveillance functionality to one or more of the clients **112** based on its processing of metagenomics sequencing results from one of more of the metagenomics sequencing centers **104** in combination with related processing performed by one or more other WWH nodes **102** utilizing metagenomics sequencing results from one or more other metagenomics sequencing centers **104**.

The surveillance functionality relating to at least one designated biological issue may comprise characterization of at least one of a disease, an infection and a contamination. For example, the characterization of at least one of a disease, an infection and a contamination may comprise characterizing the disease, infection or contamination as involving genomic material from multiple ones of the biological samples sequenced by different ones of the metagenomics sequencing centers **104**.

Provision of the surveillance functionality in some embodiments may involve generating a hit abundance score matrix, and performing a biclustering operation on the hit abundance score matrix. The hit abundance score matrix in such an embodiment may comprise, for example, a plurality of the hit abundance score vectors, with either the rows or the columns of the hit abundance score matrix corresponding to respective different ones of the biological samples and the other of the rows and columns of the hit abundance score matrix corresponding to respective different ones of the target genomic sequences.

The biclustering operation may be performed on the hit abundance score matrix by processing the hit abundance score matrix in the form of a bipartite graph in which a first set of nodes represents respective ones of the biological samples, a second set of nodes represents respective ones of the target genomic sequences, and edges between nodes in the first set and nodes in the second set represent hit abundance scores of the hit abundance score vectors of the hit abundance score matrix.

Numerous other types of surveillance functionality not necessarily involving hit abundance matrices and biclustering may be provided in other embodiments.

The particular processing operations and other system functionality described in conjunction with the flow diagram of FIG. 2 are presented by way of illustrative example only, and should not be construed as limiting the scope of the invention in any way. Alternative embodiments can use other types of processing operations for implementing metagenomics-based biological surveillance functionality. For example, the ordering of the process steps may be varied in other embodiments, or certain steps may be performed concurrently with one another rather than serially. Also, one or more of the process steps may be repeated periodically for different types of surveillance functionality, or multiple instances of the process can be performed in parallel with one another on different WWH nodes or other types of processing nodes implemented within a given metagenomics-based surveillance system.

It is to be appreciated that functionality such as that described in conjunction with the flow diagram of FIG. 2 can be implemented at least in part in the form of one or more software programs stored in memory and executed by a processor of a processing device such as a computer or server. As will be described below, a memory or other storage device having executable program code of one or more software programs embodied therein is an example of what is more generally referred to herein as a "processor-readable storage medium."

Additional details relating to the operation of metagenomics-based biological surveillance systems will now be described with reference to the FIG. 1 embodiment as well as other illustrative embodiments.

FIG. 3 illustrates distinctions between example metagenomics sequencing used in the metagenomics-based biological surveillance system of FIG. 1 and culture-based isolation sequencing.

The upper portion of the figure illustrates culture-based isolation sequencing. As mentioned previously, in accordance with typical culture-based isolation sequencing, a biological sample is subject to dilution with a growth medium and then incubated to promote isolation and growth of particular desired cells. The resulting culture is then subject to sequencing which produces a sequencing result comprising genomic reads of only one or more specifically

cultured organisms. Such culture-based isolation sequencing suffers from a number of significant drawbacks as outlined elsewhere herein.

The lower portion of the figure illustrates metagenomics sequencing such as that which is performed in one of the metagenomics sequencing centers 104 on a given biological sample obtained from a sample source in the corresponding one of the sample source sets 110. The metagenomics sequencing process advantageously avoids the drawbacks of culture-based isolation sequencing. More particularly, the metagenomics sequencing results for a given one of the biological samples as illustrated in the lower portion of FIG. 3 comprises a complete sequencing of the biological sample performed without utilization of a culture-based pathogen isolation process. The complete sequencing in this particular embodiment is assumed to comprise a set of reads for all organisms in the sample.

It should be noted that the metagenomics sequencing result for a given biological sample obtained from a single sample source may comprise millions of short reads. As noted above, the sample sources providing the biological samples that are processed in the metagenomics sequencing centers 104 in the FIG. 1 embodiment illustratively comprise one or more of water sources, food sources, agricultural sources and clinical sources, as well as additional or alternative sources, in any combination. For example, the sample source can comprise a patient, a specimen, or an environment.

FIG. 4 illustrates an example of collective processing of a genomic comparison component and an epidemiologic comparison component to further characterize a disease, infection or contamination. More particularly, in this embodiment, a metagenomics-based biological surveillance system 400 includes a distributed ecogenome monitoring and characterization block 410 and a distributed epidemiological interpretation block 420. The blocks 410 and 420 are assumed to operate at least in part in parallel with one another utilizing metagenomics sequencing results obtained from multiple ones of the metagenomics sequencing centers 104. Outputs of the blocks 410 and 420 are utilized as inputs to an iterative and distributed surveillance function block 430 of the surveillance system 400.

In some implementations of the system 400, the distributed ecogenome monitoring and characterization block 410 is used to provide functionality such as vaccine discovery and early warnings. This may illustratively involve characterizing a disease, infection or contamination as comprising genetic material from various gene units or other target genomic sequences. The distributed epidemiological interpretation block 420 can be utilized to detect spreading patterns and place of origin. For example, epidemiologic investigation may be utilized to establish a connection between two patients in a transmission tree or other type of graph based on a comparative index between those patients.

The iterative and distributed surveillance function block 430 can utilize such information from the blocks 410 and 420 to perform functions such as deploying the vaccine or controlling spread.

The FIG. 4 embodiment is an example of an arrangement that utilizes a genomic comparison component in combination with an epidemiological comparison component. In some arrangements of this type, results of metagenomics sequencing performed on biological samples from respective sample sources are obtained, and particular ones of the biological samples that are related to a disease, infection or contamination are identified based at least in part on the results of metagenomics sequencing. A genomic comparison

component may then be generated comprising hit abundance score vectors for respective ones of the identified samples. Additionally, an epidemiologic comparison component is generated, illustratively comprising a graph in which nodes corresponding to patients are connected in the graph based at least in part on patient comparative indexes. Portions of the genomic comparison component are collectively processed with portions of the epidemiologic comparison component to further characterize the disease, infection or contamination. A profile of the disease, infection or contamination, possibly in a data model of the type described elsewhere herein, can then be updated based at least in part on the further characterization. Also, one or more patient comparative indexes may be updated based at least in part on the further characterization. This process can be iteratively repeated for additional results of metagenomics sequencing performed on additional biological samples from respective additional sample sources.

The collective processing of portions of the genomic comparison component with portions of the epidemiologic comparison component may comprise combining portions of the genomic comparison component with portions of the epidemiologic comparison component to further characterize the disease, infection or contamination.

Additionally or alternatively, such collective processing may comprise generating an outbreak tree or other type of outbreak graph for the disease, infection or contamination utilizing both the genomic comparison component and the epidemiologic comparison component. In some embodiments, a community contact detection algorithm may be applied as a preprocessing operation prior to generating the outbreak graph.

As another example, the collective processing referred to above may comprise utilizing one or more of the portions of the epidemiologic comparison component in a preprocessing operation to reduce a biclustering sample space of the genomic comparison component. Such a preprocessing operation can more particularly utilize epidemiological data including at least one of time ranges, community contacts and symptoms to isolate subsets of samples to be subject to a biclustering operation.

As a further example, the collective processing of portions of the genomic comparison component with portions of the epidemiologic comparison component may comprise providing feedback from profile searching of a hit abundance score vector of a new biological sample against hit abundance score vectors of previous biological samples. In such an embodiment, if a match is found between the hit abundance score vector of the new biological sample and one of the hit abundance score vectors of the previous biological samples, the new biological sample may be subject to re-clustering based at least in part on the matching one of the previous biological samples.

It is also possible in these and other embodiments to associate a particular patient with a particular disease, infection or contamination based at least in part on statistical decision making utilizing respective portions of the genomic comparison component and the epidemiologic comparison component.

The above-described features of embodiments involving processing of both genomic comparison component and the epidemiologic comparison component are presented as illustrative examples only, and should not be considered as limiting in any way.

FIG. 5 illustrates the generation of global view information using metagenomics sequencing results from multiple metagenomics sequencing centers in different geographic regions.

In the FIG. 5 embodiment, a metagenomics-based biological surveillance system 500 comprises first, second and third metagenomics sequencing centers 504-1, 504-2 and 504-3. Each of the metagenomics sequencing centers 504 is configured to perform metagenomics sequencing on biological samples from respective sample sources in a corresponding data zone. These metagenomics sequencing centers are further assumed to be geographically distributed relative to one another. For example, each may correspond to a different one of a plurality of data centers distributed worldwide.

A clinician, researcher or other user 515 associated with a client 512-1 in this embodiment receives global view information that is generated using local view information associated with respective ones of the sequencing centers 504. The global view information is more particularly presented to the user 515 via a graphical user interface (GUI) of a computer terminal of the client 512-1.

The metagenomics sequencing centers 504 of the system 500 are configured to perform metagenomics sequencing on a respective sets of biological samples. For example, the first metagenomics sequencing center 504-1 is configured to perform metagenomics sequencing on a first set of biological samples. Metagenomics sequencing results from the first metagenomics sequencing center 504-1 are processed with additional metagenomics sequencing results from the other metagenomics sequencing centers 504-2 and 504-3 for respective additional sets of biological samples. The first and additional sets of biological samples may comprise, for example, patient samples from clinical sample sources. The metagenomics sequencing centers 504 are also assumed to have access to respective sets of local epidemiological data relating to the patient samples local to each of the centers.

The processing of metagenomics sequencing results in this embodiment is illustratively performed in conjunction with the associated epidemiological data accessible to respective ones of the first and additional metagenomics sequencing centers 504-1, 504-2 and 504-3 in order to generate the global view information that is provided to the client 512-1. The global view information illustratively characterizes epidemiological relationships between the metagenomics sequencing results from the first and additional metagenomics sequencing centers 504-1, 504-2 and 504-3.

For example, as illustrated in FIG. 5, each of the metagenomics sequencing centers 504 has access to a different portion of a graph, and the global view information provided to the client 512-1 comprises a complete graph. More particularly, sequencing centers 504-1, 504-2 and 504-3 have access to respective local portions of the graph that include respective sets of nodes {v1, v2, v3}, {v4, v5, v9} and {v6, v7, v8}. The global view information comprises the complete graph that includes all of these sets of nodes and their associated interconnections.

By way of example, the nodes of the complete graph may correspond to respective biological samples sequenced by respective ones of the metagenomics sequencing centers 504 with the edges between the nodes are weighted by sample-to-sample comparison scores of the metagenomics sequencing results.

Numerous other types and arrangements of graphs may be used in these and other embodiments. The term "graph" as used herein is intended to be broadly construed so as to encompass other similar arrangements such as trees.

As another example, the global view information may comprise a global epidemiological tree generated utilizing a plurality of local epidemiological trees provided as respective portions of the metagenomics sequencing results from different ones of the first and additional metagenomics sequencing centers **504**. Again, such trees are considered examples of what are more generally referred to herein as “graphs.”

A global epidemiological tree of this type may comprise a transmission tree in which each node corresponds to a different biological sample and a directed edge from one node to another node within the transmission tree is indicative of an epidemiological relationship between those two nodes. Another example of a graph of this type will be described below in conjunction with FIG. **30**.

The global epidemiological tree may alternatively comprise, for example, a phylogenetic tree in which the biological samples correspond to respective leaf nodes and are hierarchically clustered within the phylogenetic tree.

In the FIG. **5** embodiment, the processing of metagenomics sequencing results from multiple ones of the sequencing centers **504** can be repeated periodically in order to update the global view information provided to the client **512-1**.

For example, the processing may be periodically repeated in accordance with a sliding time window. In conjunction with a given repetition of the processing one or more nodes corresponding to new biological samples falling within the sliding time window may be added to the graph and one or more nodes corresponding to previous biological samples falling outside the sliding time window may be removed from the graph.

In some embodiments, a given one of the metagenomics sequencing centers **504** generates the global view information global view information responsive to a topological query from a requesting client. Additionally or alternatively, at least portions of the global view information can be generated in one or more WWH nodes of the system that are in communication with the metagenomics sequencing centers.

The global view information may characterize an actual or potential outbreak of a disease, an infection or a contamination. Accordingly, the global view information may be used in some embodiments to predict a spread pattern for an actual or potential outbreak of a disease, an infection or a contamination. This may be facilitated in some embodiments by applying a community contact detection algorithm in conjunction with generating the global view information.

The global view information can additionally or alternatively be used for other purposes, such as identifying failures in one or more preventive or sanitary controls.

The FIG. **5** embodiment may be viewed as one possible example of an automation of at least a portion of the distributed epidemiological interpretation block **420** of FIG. **4**. Accordingly, it may be used in separate from or in combination with distributed ecogenome monitoring and characterization.

It is to be appreciated that the FIG. **5** embodiment and other embodiments herein can be implemented using a WWH application running on a WWH platform. In such an arrangement, metagenomics sequencing results may be obtained in a first processing node from one or more metagenomics sequencing centers in a first data zone associated with the first processing node, and the first processing node configured for communication with one or more additional processing nodes via one or more networks. In such an arrangement, each of the additional processing nodes may obtain additional metagenomics sequencing results

from one or more metagenomics sequencing centers in respective additional data zones associated with the additional processing nodes. The additional metagenomics sequencing results are received in the first processing node from the one or more additional processing nodes via the one or more networks. The metagenomics sequencing results obtained from the one or more metagenomics sequencing centers in the first data zone are processed with the additional metagenomics sequencing results from the one or more metagenomics sequencing centers in the respective additional data zones to generate the global view information. Such global view information characterizing relationships between the metagenomics sequencing results from the metagenomics sequencing centers in the first and additional data zones. The global view information is then provided to a requesting client.

In an embodiment of this type, each of at least a subset of the processing nodes comprises at least one WWH node configured to perform operations in accordance with at least one supported framework of a YARN cluster on one or more corresponding portions of the metagenomics sequencing results. Such WWH nodes of a WWH platform are considered examples of what are more generally referred to herein as “worldwide data nodes” or still more generally as “processing nodes.”

By way of example, a WWH application running on a WWH platform may be used to automate the generation of a global epidemiological tree or other type of global view information from multiple local epidemiological trees or other types of local view information associated with respective sequencing centers. Each such sequencing center may be associated with a different WWH node and corresponding YARN cluster in a multi-cluster distributed data processing platform.

A WWH platform can be used to automatically infer the connections between the local partial views of the different sequencing centers **504** in the FIG. **5** embodiment. In such an arrangement, for example, each of the sequencing centers **504** can have an associated WWH node with the multiple WWH nodes cooperating with one another to compile and deliver the global view information to the client.

Each WWH node associated with a corresponding one of the metagenomics sequencing centers **504** illustratively computes the local portion of the graph for that sequencing center. This includes the computations for all nodes and edges residing within the corresponding cloud of that sequencing center as illustrated in FIG. **5**. The edges between the different local portions can be computed by a particular one of the WWH nodes based on information provided by other ones of the WWH nodes.

Such functionality may include operations such as graph computation based on comparative metagenomics, and dynamic graph recalculation including node addition and deletion. The WWH platform in embodiments of the type described above facilitates the automation of the process by permitting processing results from one WWH node to be aggregated with processing results from other WWH nodes and by providing the corresponding aggregated results back to the requesting client.

In some embodiments, a metagenomics-based biological surveillance system is configured to leverage Big Data profiles and associated Big Data analytics in processing metagenomics sequencing results in order to more accurately and efficiently predict, detect, track or otherwise characterize an outbreak of a disease, infection or contamination across multiple geographic regions or other types of data zones.

For example, in an illustrative embodiment involving use of Big Data profiles, a metagenomics-based biological surveillance system is configured to obtain results of metagenomics sequencing performed on biological samples from respective sample sources, to generate hit abundance score vectors for respective ones of the samples based at least in part on the metagenomics sequencing results, to obtain epidemiological data relating to at least one of a disease, infection or contamination characterized by one or more of the hit abundance score vectors, and to generate patient comparative indexes based at least in part on the epidemiological data. The system is further configured to obtain one or more Big Data profiles relating to one or more of the hit abundance score vectors and one or more of the comparative indexes, and to provide surveillance functionality utilizing a combination of the hit abundance score vectors and the patient comparative indexes based at least in part on information derived from the one or more Big Data profiles.

The hit abundance score vectors and the patient comparative indexes may be periodically or otherwise updated based at least in part on the one or more Big Data profiles. This may involve, for example, increasing or decreasing a given one of the comparative indexes in accordance with information derived from the one or more Big Data profiles.

A given one of the Big Data profiles may comprise at least one of location information, climate information, environment information and social media information associated with at least one of the hit abundance score vectors and the patient comparative indexes.

In some embodiments, the surveillance functionality comprises implementing a machine learning training process that associates particular ones of the hit abundance score vectors and the patient comparative indexes with particular types of information derived from the one or more Big Data profiles. Such surveillance functionality illustratively comprises detecting at least one characteristic of an actual outbreak of a particular disease, infection or contamination. Additionally or alternatively, the surveillance functionality may comprise predicting at least one characteristic of potential outbreak of a particular disease, infection or contamination, such as a location and an affected population of the potential outbreak.

The surveillance functionality in these and other embodiments may be configured to bound a search space of the hit abundance score vectors and the patient comparative indexes based at least in part on the information derived from the one or more Big Data profiles. For example, the hit abundance score vector search space may be bounded by limiting the search space to hit abundance score vectors associated with sample sources that are within a designated proximity to a location derived from the one or more Big Data profiles. This yields a more efficient search with increased precision.

These and other embodiments can be implemented utilizing distributed data processing nodes, such as WWH nodes arranged in multiple clusters associated with respective sequencing centers. Such WWH nodes are illustratively configured to perform operations in accordance with at least one supported framework of a YARN cluster on corresponding portions of metagenomics sequencing results.

In WWH embodiments that utilize Big Data profiles, a multi-cluster WWH platform can be configured to compute portions of Big Data profiles relating to climate, environment, social media and numerous other types of information and to characterize relationships of the Big Data profiles with other profiles maintained within the platform. Such

embodiments can continuously iterate and produce additional output results as Big Data profiles are updated or otherwise modified.

The use of Big Data profiles and associated profile characteristics advantageously allows for more accurate and efficient computation of hit abundance score vectors, comparative indexes and other types of information utilized in providing biological surveillance functionality in illustrative embodiments disclosed herein. For example, portions of a Big Data profile relating to climate, environment or social media can be used to increase or decrease the comparative index between two patients.

FIGS. 6-8 show examples of relationships between Big Data profiles and associated information elements in illustrative embodiments.

With reference initially to FIG. 6, a given Big Data profile is associated with a plurality of other profiles, including a disease profile, a medical history profile, travel logs, location information, a sample profile, an ecogenome profile and a patient profile.

FIGS. 7 and 8 each illustrates association between particular information of a Big Data profile and particular types of information in disease, patient and location profiles.

The associations between the Big Data profiles and other types of profiles as illustrated in FIGS. 6-8 can be based at least in part on machine learning or other types of automated training. For example, the Big Data environment relating to a flood F1 can be trained to be statistically associated with a particular disease such as pneumonia ST316 and a particular patient profile such as infants T1 as shown in FIG. 7. Based on the training data that is assembled from multiple sources, prediction can be made regarding types of diseases that have the potential to emerge, and affected populations, locations, etc. This kind of prediction can provide important benefits to public health authorities.

These are only examples, and numerous other types of Big Data profiles and other associated profiles can be used in other embodiments.

Additional details regarding Big Data profiles and associated Big Data analytics that can be implemented in illustrative embodiments of the present invention are described in U.S. Pat. No. 9,031,992, entitled "Analyzing Big Data," which is commonly assigned herewith and incorporated by reference herein.

The example profiles and corresponding associations illustrated in FIGS. 6-8 are illustratively configured in accordance with a data model.

In some embodiments, metagenomics sequencing results from a plurality of metagenomics sequencing centers associated with respective data zones are processed and a data model is configured based at least in part on the metagenomics sequencing results. One or more reasoning operations can then be performed over the data model to infer relationships between entities of the data model that are not directly expressed by the data model, and the data model updated based at least in part on the inferred relationships. These operations can be repeated as additional metagenomics sequencing results are obtained from one or more of the metagenomics sequencing centers.

Portions of the data model illustratively comprise respective profiles each characterizing at least one of a disease, infection or contamination based at least in part on the metagenomics sequencing results. For example, a given one of the profiles characterizing at least one of a disease, an infection and a contamination may comprise a characterization of the disease, infection or contamination as involving genomic material from multiple ones of a plurality of

biological samples sequenced in different ones of the data zones by corresponding different ones of the metagenomics sequencing centers.

The data model in some embodiments may be in the form of a graph in which nodes correspond to respective profiles and edges between the nodes denote relationships between the corresponding profiles.

Updating the data model based at least in part on the inferred relationships may include one or more of updating a node corresponding to one of the profiles, adding a node corresponding to a new profile, deleting a node corresponding to an existing profile, and inserting one or more additional edges between respective pairs of the profiles of the graph.

The performance of one or more reasoning operations over the data model may involve applying a graph traversal tool to the graph in conjunction with the performance of the one or more reasoning operations.

Numerous other types of data models can be used in other embodiments, including models not based on graphs.

For example, data models in illustrative embodiments can be configured to utilize combinations of one or more of metagenomes, ecogenomes, pan-genomes and other types of genomic information to characterize diseases, infections or contaminations. Such data models are advantageously configured to characterize a disease, infection or contamination as being associated with a combination of genomes that when present together in each of one or more samples yield a certain set of conditions.

This approach accommodates genome plasticity as well as a wide variety of known and unknown diseases, infections or contaminations that can be characterized as a combination of genomic sequences of microbial genomes observed in the past. The data model in a given embodiment can include model elements for core genomes, including multiple species or strains, as well as for accessory genes such as plasmids, phages, pathogenicity islands and operons. Such a data model is configured to recognize that accessory genes can be horizontally transferred across different strains of the same species.

The data models may be implementation-independent so as to be suitable for use on any genomic processing framework to support processing operations associated with reasoning, analyzing and dynamically classifying diseases, infections or contaminations as they emerge. This includes polymicrobial diseases, infections or contaminations that may be caused by combinations of viruses, bacteria, fungi and parasites. For example, one microorganism when present may provide a niche for other pathogenic microorganisms to colonize, or may otherwise predispose a host to colonization by other microorganisms. As another example, two or more non-pathogenic microorganisms when present together in a given sample may be identified as the cause of a disease, infection or contamination. The data models used in the illustrative embodiments are advantageously configured to support such characterizations.

Some embodiments perform metagenomics processing utilizing what are referred to herein as “gene units” where a given gene unit illustratively comprises a portion of an assembly or other processing of one or more samples. Each such assembly or processing may result in many gene units each potentially thousands to tens of thousands of nucleotides in length. It should be noted that a “gene unit” as the term is utilized herein is intended to be broadly construed so as to encompass, for example, arrangements of genomic information that do not meet the formal definition of a gene as they are not necessarily verified or fully annotated.

Accordingly, a given “gene unit” herein may but need not comprise a gene or other particular functional entity within a given genome. Gene units are considered to be an example of what is more generally referred to herein as “target genomic sequences.” Such target genomic sequences may be part of an ecogenome, a pan-genome or a metagenome, or other arrangements and groupings of genetic information.

In some embodiments, gene units comprise locally-available pre-processed sequenced genomic data of a given metagenomics sequencing center, such as assembled pathogen gene units collected locally and not yet shared with global databases. Gene units may be augmented with metadata such as patient symptoms, time and location.

As mentioned previously, the metagenomics sequencing applied to a given sample results in what are referred to herein as “reads.” Such reads may be utilized to generate a sample profile. For example, a sample profile can be generated by aligning the reads of a given sample to multiple gene units. The sample profile may therefore comprise a set of alignment histograms relative to respective gene units. Examples of such alignment histograms will be described below in conjunction with FIGS. 9 through 12.

It was noted above that each of the metagenomics sequencing centers **104** may comprise one or more databases for storing metagenomics sequencing results and additional or alternative types of data. For example, in some embodiments, it is assumed that each of the metagenomics sequencing centers **104** has both a sample database and a gene unit database, although other types and arrangements of databases can be used.

The sample profile in some embodiments comprises what is referred to herein as a “global” sample profile in that alignment histograms are generated for the reads of the sample against gene units from different ones of the metagenomics sequencing centers **104**. This is in contrast to a “local” sample profile which includes alignment histograms that are generated for the reads of the sample against only one or more gene units that are present in the local gene unit database of the single metagenomics sequencing center **104** that performed the metagenomics sequencing on the sample.

The above-noted sample database of a given one of the metagenomics sequencing centers may comprise local sample profiles, global sample profiles or both local and global sample profiles for each of the samples that are sequenced by that center.

More particularly, the sample database of a given one of the metagenomics sequencing centers **104** illustratively comprises, for each of the samples processed in that center, the set of reads for the sample, at least one sample profile for the sample, and a metadata file. The reads are the outputs of the metagenomics sequencing applied to the sample, and as indicated above there may be millions of reads for each sample. The sample profile may comprise a global sample profile generated using metagenomics sequencing results from multiple metagenomics sequencing centers. Such a global sample profile may therefore change each time any processing relating to the sample or its reads is performed within the biological surveillance system, and is influenced by variables such as the sequencing centers used, the content of the gene units that exist in the gene unit databases of those sequencing centers, and the specific algorithms used to calculate the alignment histograms. The metadata file illustratively contains any additional information that may have been obtained about the source of the sample or the sample itself, such as patient symptoms, time and location.

The above-noted gene unit database of a given one of the metagenomics sequencing centers **104** may comprise an

accumulated set of assembled or partially-assembled gene units that have been observed from samples collected locally in the given metagenomics sequencing center over some period of time or since the center started its activity. The gene units may not be unique to a specific sample and could in fact be assembled based on merging several samples together. The gene unit database in some embodiments comprises a local pathogen database or other types of local databases.

Accordingly, the gene unit database can include data from multiple sources, including data from metagenomics sequencing of multiple samples, possibly including sequencing samples that are collected locally for other purposes. It may include data that has not yet been shared with global databases such as NCBI, GenBank and others. Additionally or alternatively, the gene unit database can include copies of gene units that already exist in one or more of these global databases.

At least a subset of the gene units in the gene unit database may each have an associated metadata file that includes information such as the time and place of data collection, patient symptom measurements, etc. For example, some gene units may aggregate patient symptom measurements from multiple samples.

As noted above, a given sample profile may comprise a set of alignment histograms relative to respective gene units. Such an alignment histogram illustratively shows for each position of a nucleotide in a given gene unit the number of reads of the sample that map to that position. The positions are also referred to as “genomic sequence positions.”

FIGS. 9, 10 and 11 show examples of alignment histograms utilized in metagenomics-based biological surveillance systems in illustrative embodiments.

Referring initially to FIG. 9, an example alignment histogram for a given sequenced sample plots base count as a function of position. More particularly, the x-axis represents the gene unit genomic sequence positions, and the y-axis represents how many reads were mapped to each position. The positive (+) area of the histogram above the x-axis shows the base counts for reads that originated from the leading or “regular” DNA strand in the sample, and the negative (−) area of the histogram below the x-axis shows the base counts for reads that originated from the complementary strand in the sample. The sign of the base counts in the negative area does not have any meaning and should be ignored. This type of alignment histogram showing separate counts for regular and complementary strands on opposite sides of the x-axis is also referred to as a “stacking” histogram.

As seen in the figure, the alignment histogram includes several parameters including depth, coverage, integral and number of reads. These parameters will each be explained in more detail below.

FIG. 10 shows a simplified example of a shorter-length version of an alignment histogram of the type illustrated in FIG. 9, with five positions along the x-axis. For each position in the gene unit, the alignment histogram counts the number of reads from the sample that are aligned to that position. As noted above, each sample includes reads from the regular and complementary DNA strands, and the corresponding counts for those reads are separated in the respective positive and negative areas above and below the x-axis. The five positions in the FIG. 10 example are denoted A, A, C, T, G, where A, T, G and C denote respective nucleotide bases of adenine, thymine, guanine and cytosine.

The depth, coverage, integral and number of reads parameters characterize the correlation between the reads of a

sample and a gene unit. The number of reads represents the total number of reads that were mapped to the gene unit.

Depth is the average count per position of the reads aligned to positions in the gene unit. For example, with reference to the alignment histogram of FIG. 10, the total count for each of the five positions on both regular and complementary strands is given by A-25, A-25, C-24, T-17 and G-18. This results in an average count per position or depth of 21.8.

Coverage is the percentage of the gene unit that is covered by the sample reads, or in other words, the percentage of the gene unit positions that have reads aligned to them or a number of reads over a certain threshold aligned to them. In the FIG. 10 example, the coverage is 100% assuming a threshold of 10 reads. In some cases, the coverage can be low even though the depth is not low. Another version of the FIG. 10 example is shown in FIG. 11, and has the same depth of 21.8, but only 60% coverage.

Integral is the total area of the histogram, and represents the total of the base counts on each strand over the positions in the gene unit. For example, with reference again to the FIG. 10 example, the integral is the sum of the counts A-25, A-25, C-24, T-17 and G-18, which yields an integral of 109. Dividing the integral by the length of the gene unit yields the depth, which is 21.8 in this example.

The depth, coverage and integral of the alignment histogram are illustratively computed as follows:

$$\text{Depth: } \frac{\sum_{0 \leq i \leq n} \text{HistR}[i] + |\text{HistC}[i]|}{n}$$

$$\text{Coverage: } \frac{\sum_{0 \leq i \leq n} X_i}{n} * 100, \text{ such that } X_i = \begin{cases} 1, & \text{HistR}[i] + |\text{HistC}[i]| > t \\ 0, & \text{else} \end{cases}$$

$$\text{Integral: } \sum_{0 \leq i \leq n} \text{HistR}[i] + |\text{HistC}[i]|$$

In the above computations, HistR[i] and HistC[i] represent how many reads were mapped to base i on the regular strand and on the complementary strand, respectively, and |HistR|=|HistC|=n, where n is the length of the gene unit, and t denotes the above-described coverage threshold.

Alignment histograms and related parameters of the type described above can be provided to a client such as a given one of the clients 112 in the FIG. 1 embodiment via a GUI. Similar GUIs can be used to present corresponding sample profiles, abundance vectors, abundance matrices or other types of information based on metagenomics processing results to a given system user.

FIG. 12 shows an example of a sample profile based on multiple alignment histograms in an illustrative embodiment. In this embodiment, the sample profile is a local sample profile denoted Sample Profile 1, assumed to be constructed for a corresponding sample denoted Sample 1. Sample Profile 1 includes first and second alignment histograms of the type shown in FIG. 9, one relative to Gene Unit 1 and another relative to Gene Unit 2, and may include similar alignment histograms for each of one or more additional gene units. As Sample Profile 1 is assumed to be a local sample profile, both of the gene units Gene Unit 1 and Gene Unit 2 are assumed to be part of the local gene unit database of the metagenomics sequencing center that performed the metagenomics sequencing on the sample. Each of the alignment histograms may be viewed as a correspond-

ing “line” of the sample profile. The sample profile in some embodiments is created within a monitoring stage of the corresponding metagenomics sequencing center. For example, such a monitoring stage may be part of the distributed ecogenome monitoring and characterization block 410 of FIG. 4. Each line in the sample profile represents the results of application of a mapping process between the reads of the samples and a gene unit entry in the gene unit database of the specific sequencing center.

In addition to the alignment histogram, a given line in the sample profile can contain related information such as one or more of the above-noted parameters including depth, coverage, integral and number of reads.

FIG. 13 shows one possible file format for a sample profile of the type shown in FIG. 12. In this example file format, a sample profile file includes a gene unit identifier, a gene unit length, a strand type, histogram values, depth, coverage, integral and number of reads. The notation EOL denotes the end of a given line of the file format. It is assumed in this embodiment that the histogram values are range encoded for compression.

A particular row in this example format corresponds to a single gene unit and has the following format:

```
<ID> <start> <end> <strand type> <hist> <depth> <coverage> <integral> <# of reads>.
```

In this row, <ID> is a gene unit identifier, <start> is a starting index, <end> is an end index (<end>-<start>=gene unit length), <strand type> is either “+” for the leading or regular DNA strand, or “-” for the complementary DNA strand, <hist> is a compressed histogram representation (“range, value!”), and <depth>, <coverage>, <integral> and <# of reads> are histogram parameters as previously described.

Again, the above histogram file format is only an example, and numerous alternative file formats can be used for sample profiles in other embodiments.

Sample profiles of the type described above are utilized to generate hit abundance score vectors in illustrative embodiments. Hit abundance score vectors are also referred to herein as “abundance vectors.” These abundance vectors are utilized in generating corresponding hit abundance score matrices, also referred to herein as “abundance matrices,” in conjunction with the provision of metagenomics-based surveillance functionality such as characterization of a disease, infection or contamination. For example, abundance vectors in some embodiments form respective rows of an abundance matrix.

Referring now to FIG. 14, generation of an example abundance vector is illustrated for a sample profile of the type shown in FIG. 12. As shown in the figure, Sample Profile 1 is used to extract an abundance vector. It is assumed for this embodiment that the Sample Profile 1 includes alignment histograms for Gene Unit 1 and Gene Unit 2 as previously described, as well as three additional gene units, denoted Gene Unit 3, Gene Unit 4 and Gene Unit 5. The five gene units utilized in generating Sample Profile 1 are denoted in the context of the present example as GU-1, GU-2, GU-3, GU-4 and GU-5, respectively.

It should be noted that the abundance vector can be built in many different ways from a given sample profile. For example, different abundance vectors can be built based on respective different ones of the depth, coverage and integral parameters previously described. Combinations of these and other parameters can also be used to construct an abundance vector. In the FIG. 14 example, it is assumed that the abundance vector is generated for Sample 1 using the depth parameter. More particularly, the abundance vector com-

prises a plurality of entries with each such entry corresponding to a different gene unit and indicating how abundant that gene unit was in the reads of the sample.

The abundance vector in the present example is illustratively denoted as the Sample 1 Abundance Vector or AV1, and has the following format:

```
AV1=[1.1 9.7 8.3 0.1 4.9]
```

This particular example of an abundance vector has as its five entries the corresponding depth values determined from the respective alignment histograms for the respective gene units GU-1, GU-2, GU-3, GU-4 and GU-5. These individual entries are as follows:

```
AV1[1]=1.1
```

```
AV1[2]=9.7
```

```
AV1[3]=8.3
```

```
AV1[4]=0.1
```

```
AV1[5]=4.9
```

Again, numerous other types of abundance vectors may be generated using the techniques disclosed herein.

It was assumed in the context of the present example that Sample Profile 1 from which the abundance vector AV1 is extracted is a local sample profile.

A global sample profile may be constructed in some embodiments by aggregating a plurality of local sample profiles each of which is based on a set of gene units locally accessible to a corresponding one of a plurality of metagenomics sequencing centers.

It is possible that a given gene unit may appear in multiple local sample profiles. In this case, the alignment histogram between the sample reads and the gene unit should be exactly or substantially the same in each of the multiple local sample profiles. Accordingly, the global sample profile can be configured to include only a single entry for the repeated gene unit, and may be supplemented with additional information indicating the number of metagenomics sequencing centers for which that gene unit was utilized in generating a corresponding portion of a local sample profile.

If the gene unit is present in only one sequencing center, the local sample profile based on that gene unit is added to the global sample profile.

Similarity between two gene units A and B in different sequencing centers can be measured in different ways. For example, similarity between A and B can be based on A and B exhibiting a sufficiently low number of single nucleotide polymorphisms (SNPs) between them, or similar lengths or other features.

In the generation of local or global sample profiles, gene units may be combined into one or more groups of similar gene units and the local or global sample profile can have a single entry for each such group of gene units rather than a single entry for each gene unit. Such arrangements may involve the sharing of gene units between multiple metagenomics sequencing centers in order to facilitate grouping of similar gene units. Publically available gene units from global databases such as NCBI, GenBank and others can be used for this purpose. Other embodiments can be configured to simply assume that the gene units are unique between metagenomics sequencing centers.

It is possible in some embodiments to use a general representation of a cluster of genes that is globally shared. Every gene unit that is sufficiently similar to the cluster can be tagged as being a gene unit of that cluster without the tagging metagenomics sequencing center being aware of other gene units that are tagged in the same way.

Additional details of illustrative embodiments will now be described with reference to FIGS. 15 through 28.

FIGS. 15 and 16 illustrate generation of reads from a given biological sample in one of the sequencing centers such as one of the sequencing centers 104 in the FIG. 1 embodiment. Referring initially to FIG. 15, a metagenomics processing block 1500 includes a sample collection block 1502 and a sequencing block 1504. The sample collection block 1502 collects a sample from a sample source such as one of the locally-accessible sample sources in one of the sets 110 in the FIG. 1 embodiment. The sample may comprise, for example, blood, saliva, water, food, or any of a wide variety of other sample types. The sample is subject to metagenomics sequencing in the sequencing block 1504 in order to generate metagenomics sequencing results comprising a plurality of reads as illustrated.

FIG. 16 shows a more detailed view of the sequencing block 1504 of the FIG. 15 embodiment. As shown, the sequencing block 1504 comprises a metagenomics sequencing block 1600, a post-processing block 1602 and a full or partial assembling block 1604. The post-processing block 1602 illustratively encompasses operations such as re-alignment, assembling, cleansing, removal of human reads and possibly other types of operations that can be applied to the output of the metagenomics sequencing block 1600. The output of the metagenomics sequencing block 1600 provides output reads for the sample, and such output reads can also be applied to the full or partial assembling block 1604 and stored in a sample database 1605. The post-processing block 1602 can generate a separate additional output of reads as illustrated. The full or partial assembling block can be used to generate one or more gene units that are stored in a gene unit database 1610.

Although the post-processing and assembling blocks 1602 and 1604 are shown in dashed outline indicating optional blocks for this embodiment, such an indication should not be construed as an indication that any other blocks are requirements of any particular implementation. For example, other embodiments can be configured which utilize different arrangements of additional or alternative processing blocks.

In some embodiments, metagenomics-based surveillance functionality is utilized to implement what is referred to herein as a “future clinic pipeline” for characterization of a disease, infection or contamination. It is to be appreciated, however, that this and many other aspects of illustrative embodiments disclosed herein are not limited to use with metagenomics sequencing arrangements, but can more generally be applied to ecogenomic information obtained through a wide variety of other mechanisms, including, for example, conventional culture-based isolation sequencing.

By way of example, in some embodiments, a distributed ecogenome monitoring and characterization block such as block 410 of FIG. 4 is configured to compare reads from a single sample against previous gene units collected at different sequencing centers scattered all over the world. The resulting global sample profile can include, for example, information about the sample itself as well as the comparison of its reads against gene units from multiple gene unit databases associated with respective ones of the sequencing centers. Such an arrangement advantageously provides a clinician or other user with access to processing results from multiple distributed sequencing centers. This allows a given sample to be compared against multiple distinct gene unit databases.

FIG. 17 shows one possible implementation of a sequencing center in an illustrative embodiment. In this embodiment, a sequencing center 1700 implements a sequencing block 1704 that may be similar to the sequencing block 1504

previously described in conjunction with FIGS. 15 and 16. The sequencing block 1704 generates a set of reads for a given sample. The reads are stored in a sample database 1705 and applied to a global early warning and monitoring system 1710. The global early warning and monitoring system 1710 receives a list of sequencing centers including identifiers of one or more additional sequencing centers as well as related information such as local sample profiles generated by those sequencing centers. The global early warning and monitoring system 1710 generates a global sample profile of the type previously described. Outputs of the global early warning and monitoring system 1710 are also used to update entries of the sample database 1705.

In some embodiments, as additional samples become available within the sequencing centers of the system, a disease characterization can be performed based on those samples. The entity interested in a disease characterization may be a clinician, a researcher or other system user. A given such user may comprise a human user or an application or other hardware or software entity that triggers the characterization process. Accordingly, the term “user” is intended to be broadly construed herein. Similarly, a client may be viewed as a type of human user or an associated processing device or similar entity.

By way of example, a hospital may utilize techniques disclosed herein to implement a patient administration system that automatically triggers the characterization process responsive to a threshold number of arriving patients presenting the same or similar symptoms within a given period of time. Similarly, a disease-monitoring organization such as the National Institutes of Health (NIH) can trigger the characterization process for a particular monitored disease under certain conditions. This may additionally or alternatively involve triggering of an automated request for sample donations from members of a wider population that may be suffering from a particular set of symptoms.

A given disease characterization process in illustrative embodiments can be configured as a multi-stage process that can be initiated at multiple ones of the stages depending upon the availability of inputs for those stages.

FIG. 18 shows an example of a multi-stage disease characterization process in an illustrative embodiment. In this embodiment, a multi-stage disease characterization process 1800 comprises four stages denoted Stage 1, Stage 2, Stage 3 and Stage 4. The characterization process 1800 may be viewed as implementing P instances of the arrangement previously described in conjunction with FIG. 17. More particularly, the characterization process 1800 comprises sample collection blocks 1802-1, . . . 1802-p, . . . 1802-P coupled to respective sequencing blocks 1804-1, . . . 1804-p, . . . 1804-P. The sample collection blocks provide respective samples that are sequenced in respective ones of the sequencing blocks to provide respective sets of reads for the corresponding samples. The characterization process 1800 further comprises global early warning and monitoring systems 1810-1, . . . 1810-p, . . . 1810-P that receive the respective sets of reads for the P samples and generate respective global sample profiles for those samples for application to a characterization block 1812. The characterization block generates partitions of an abundance matrix of the type previously described. The partitioning of the abundance matrix may utilize a biclustering algorithm.

The abundance matrix partitions in some embodiments comprise what are referred to elsewhere herein as respective “outbreak modules” that characterize the outbreak of a

disease, infection or contamination. Numerous other types of abundance matrix partitions can be utilized in other embodiments.

In Stage 1 of the characterization process **1800**, samples are collected utilizing the sample collection blocks **1802**. In Stage 2, the collected samples are sequenced by the sequencing blocks **1804** in order to generate reads for each sample. In Stage 3, global early warning and monitoring is performed utilizing the systems **1810** in order to generate global sample profiles. In Stage 4, the set of global sample profiles is used to characterize the disease in the characterization block **1812**.

In the FIG. **18** embodiment, the characterization process **1800** utilizes selected samples that can be located in different sequencing centers. The selection of samples via the respective sample collection blocks **1802** can be performed manually or in an automated manner. For example, sample selection can be automated using an application program that selects as the set of samples to be processed those samples that share certain common characteristics and should therefore be considered related. As mentioned previously, the samples in this embodiment can be collected in the same or different sequencing centers.

In some embodiments, a WWH application configured to run on a WWH platform is utilized to provide this sample selection functionality as well as other related functionality of the characterization process **1800**.

It should be noted that the characterization process **1800** can be started from various initiation points in different ones of the stages, again depending upon the availability of at least a portion of the required inputs for that stage. For example, the process can start at Stage 2, utilizing only samples that have been previously collected but without triggering the collection of any additional samples. As another example, it can start at Stage 3, utilizing only reads of samples that have previously been sequenced. As yet another example, it can start at Stage 4, by leveraging a set of global sample profiles that have been previously generated. Numerous alternative arrangements involving more or fewer processing stages and different variations in initiating point can be used in other embodiments.

The various processing operations performed within a given stage can be performed at least in part in parallel with one another. Alternatively, it is possible for each sample to be analyzed at a different instant in time. For example, Sample 1 may have been collected three months prior to Sample p, or at the same time as Sample p. The particular subsets of processing blocks **1802**, **1804** and **1810** applied to respective ones of the samples can therefore execute in distinct, potentially non-overlapping time periods. As another example, the transitions from stage to stage can be highly sequential. For example, the process **1800** can be configured such that each one of the stages is completely finished before the next one starts. Again, these are only examples, and numerous alternative arrangements are contemplated.

FIG. **19** shows a more detailed view of a given one of the global early warning and monitoring systems **1810-1** of FIG. **18**. The global early warning and monitoring systems **1810-1** receives reads from a single sample, and a list of O sequencing centers. A distributed monitoring component **1900** generates O local sample profiles for the single sample. These local sample profiles are denoted Local Sample Profile 1, . . . Local Sample Profile o, . . . Local Sample Profile O, and are applied to a global sample profile generator **1902**. In this embodiment, the global sample profile generator **1902** generates a global sample profile as an

aggregation of the O local sample profiles provided to it by the distributed monitoring component **1900**. The other global early warning and monitoring systems **1810-2** through **1810-P** of the FIG. **18** embodiment are assumed to be configured in a similar manner.

Referring now to FIG. **20**, the distributed monitoring component **1900** can be seen in greater detail. As illustrated in the figure, the distributed monitoring component **1900** comprises a plurality of ecogenome monitoring components **2000-1**, . . . **2000-o**, . . . **2000-O**, each associated with a different one of a plurality of sequencing centers. The ecogenome monitoring components **2000** produce respective ones of the local sample profiles denoted Local Sample Profile 1, . . . Local Sample Profile o, . . . Local Sample Profile O. The local sample profiles are generated by mapping the reads for the single sample to gene units that are local to the gene unit database of the corresponding sequencing center. These local sample profiles are subsequently applied to the global sample profile generator **1902** and utilized to generate a global sample profile in the manner previously described.

FIG. **21** shows a more detailed view of a given one of the ecogenome monitoring components **2000-1** of FIG. **20**. The ecogenome monitoring component **2000-1** receives reads from a single sample, and processes the reads using a pre-processing block **2115** and a read mapping block **2116**. The pre-processing block **2115** organizes the reads into gene units, for example, using FASTA format or another suitable format.

The read mapping block **2116**, which may illustratively implement a modified Cloud Burst mapping algorithm, maps the reads to target gene units from a gene unit database **2110** local to the corresponding sequencing center. The target gene units from the gene unit database illustratively utilize a multi-FASTA format, although numerous alternative target gene unit formats can be used in other embodiments. The output of the read mapping block **2116** illustratively comprises a list of hits, possibly in a BED format. An example of the BED format is shown in FIG. **29** and will be described in more detail below.

The list of hits from the read mapping block **2116** is applied to a crude sample profile generator **2117** which generates a crude local sample profile in a manner to be described in conjunction with FIG. **24**. The term "crude" in the context of this embodiment refers to any form of sample profile that has not been normalized, aligned or subject to one or more other similar operations. The crude local sample profile is further processed in a sample profile generator **2118** to generate a local sample profile. In other embodiments, the crude local sample profile generator **2117** can be eliminated such that the ecogenome monitoring component **2000-1** includes only a single profile generator suitable for generating a local sample profile of the type described elsewhere herein. It is to be appreciated that a wide variety of different types of local sample profiles can be used in illustrative embodiments.

The other ecogenome monitoring components **2000-2** through **2000-O** of the FIG. **20** embodiment are assumed to be configured in a manner similar to that illustrated in FIG. **21** and described above.

Referring now to FIG. **22**, the operation of the read mapping block **2116** is illustrated in more detail. In this embodiment, a set of reads **2200** from a single sample are mapped by the read mapping block **2116** against gene units from the gene unit database **2110**. The set of reads **2200** includes reads denoted Read 1, Read 2, Read 3 and Read 4. The gene unit database **2110** comprises gene units denoted

Gene 1 and Gene 2. The resulting output of the read mapping block **2116** comprises a list of hits **2202**, possibly in BED file format, of the reads against the gene units. The list of hits **2202** includes, for example, a hit of the first read denoted Read 1 against Gene Unit 1 associated with Genome 1.

FIG. **23** shows a more detailed view of the read mapping block **2116** of FIGS. **21** and **22**. In this embodiment, the read mapping block **2116** comprises a read mapping component **2300** comprising a plurality of individual read mapping units **2302-1**, . . . **2302-t**, . . . **2302-T** configured to perform read mapping functions for a set of reads of a given sample against respective gene units denoted Gene Unit 1, . . . Gene Unit t, . . . Gene Unit T from gene unit database **2110** in order to generate respective lists of hits denoted List of Hits 1, . . . List of Hits t, . . . List of Hits T. The lists of hits from read mapping component **2300** are applied to a read mapping aggregator and re-alignment block **2304** in order to generate the list of hits at the output of the read mapping block **2116**, which as mentioned previously may be in BED format. It should be noted that the term "re-alignment" as used in this context may include any of a number of different operations relating to adjustments associated with read mapping.

With reference now to FIG. **24**, one possible implementation of the crude sample profile generator **2117** is shown. The sample profile generator **2117** in this embodiment comprises a histogram generation block **2400** for a set of S gene units. The histogram generation block **2400** comprises a plurality of individual histogram generators **2402-1**, . . . **2402-s**, . . . **2402-S** each generating an alignment histogram of the type described elsewhere herein for hit files corresponding to respective gene units denoted Gene Unit 1, . . . Gene Unit s, . . . Gene Unit S. The resulting histograms are applied to a histogram combiner and profile assembler **2404** which processes the histograms to generate the crude local sample profile. Additional processing is subsequently applied to the crude local sample profile in order to generate the local sample profile. An arrangement similar to that shown in FIG. **24** can be used as a singular sample profile generator in an embodiment without a crude sample profile generator.

Additional illustrative embodiments involving distributed ecogenomic monitoring and characterization will now be described with reference to FIGS. **25** through **27**.

Referring initially to FIG. **25**, a distributed ecogenomic monitoring and characterization block **2500** comprises a distributed monitoring component **2502** providing distributed monitoring across many samples. The distributed monitoring component **2502** includes individual distributed ecogenomic monitoring blocks denoted **2504-1**, . . . **2504-p**, . . . **2504-P**, configured to process reads from respective samples denoted Sample 1, . . . Sample p, . . . Sample P in order to generate respective sample profiles denoted Sample Profile 1, . . . Sample Profile p, . . . Sample Profile P. These sample profiles are applied to a characterization block **2510** to generate abundance matrix partitions of the type described elsewhere herein.

It should be noted that the characterization block **2510** of the distributed ecogenomic monitoring and characterization of the type illustrated in FIG. **25** can be triggered in a wide variety of different ways. For example, the characterization can be triggered by an automated determination that a set of samples has certain designated characteristics in common or that the samples are from patients experiencing similar symptoms or other characteristics such as location. It is also possible that a clinician, researcher or other user may simply decide to explore the existence or absence of certain char-

acteristics in a set of samples utilizing the surveillance functionality disclosed herein.

FIG. **26** shows a more detailed view of the characterization block **2510**. In this embodiment, the characterization block **2510** more particularly comprises an abundance matrix generator **2600** that receives as its inputs the sample profiles denoted Sample Profile 1, . . . Sample Profile p, . . . Sample Profile P. These are processed in the abundance matrix generator **2600** to generate a global abundance matrix that is applied to a matrix partition generator **2602** that illustratively implements a biclustering algorithm, although other types of matrix partitioning algorithms can be used in other embodiments. For example, alternative matrix partitioning algorithms implemented in other embodiments can include any of a number of known matrix subgrouping algorithms. The matrix partition generator **2602** generates as its outputs a set of abundance matrix partitions denoted Abundance Matrix Partition 1, . . . Abundance Matrix Partition r, . . . Abundance Matrix Partition R.

The abundance matrix generator **2600** of FIG. **26** is shown in a more detailed view in FIG. **27**. In this embodiment, the abundance matrix generator comprises an abundance vector generator component **2700** operating across many samples. The abundance vector generator component **2700** comprises individual abundance vector generators **2702-1**, . . . , **2702-p**, . . . **2702-P**, configured to process respective ones of the sample profiles Sample Profile 1, . . . Sample Profile p, . . . Sample Profile P in order to generate respective abundance vectors as illustrated. These abundance vectors are applied to an aggregation block **2704** that combines the abundance vectors to form the global abundance matrix.

The abundance matrix in some embodiments is configured such that the rows of the matrix are respective abundance vectors generated for respective samples, and the columns are respective gene units. In such an arrangement, each entry [i,j] of the abundance matrix represents how abundant gene unit j was in sample i. For an embodiment with N abundance vectors and M gene units, the abundance matrix is an N×M matrix. Alternative types and arrangements of abundance matrices can be used in other embodiments. For example, in other embodiments, the abundance vectors can be respective columns of the matrix and the gene units can be respective rows of the matrix. FIG. **26** illustrates that a biclustering algorithm or other type of matrix partitioning operation is applied to the abundance matrix in conjunction with the characterization of a disease, infection or contamination.

The matrix partition generator **2602** of FIG. **26** is shown in a more detailed view in FIG. **28**. In this embodiment, the matrix partition generator **2602** comprises a submatrix generator component **2800** that includes individual submatrix generators **2802-1**, . . . , **2802-r**, . . . **2802-R**, each configured to process the global abundance matrix from the abundance matrix generator **2600**. The matrix partition generator **2602** further comprises a submatrix processor **2804** which processes the submatrices to provide the corresponding output abundance matrix partitions denoted Abundance Matrix Partition 1, . . . Abundance Matrix Partition r, . . . Abundance Matrix Partition R.

In some embodiments, the submatrix processor **2804** comprises an outbreak module generator and the abundance matrix partitions comprise respective outbreak modules. Each abundance matrix partition in such an embodiment illustratively comprises a submatrix (S',G') where S' denotes a subset of the samples and G' denotes a subset of the gene units. For example, such a submatrix illustratively represents a group of diseased patients that share the common denomi-

nator G' denoting the gene units of a corresponding disease. The common denominator G' is an example of what is referred to herein as an outbreak module and may be stored for future computations and comparison. Each characterization event on an abundance matrix can produce multiple outbreak modules.

An outbreak module score may be attached by the submatrix processor **2804** to the corresponding submatrix, with the attached score representing the statistical significance of that submatrix among all possible submatrices. Based on S' an outbreak participants module can be generated, illustratively comprising a vector of all samples in the outbreak module having the attached score. A similar vector may be created based on the outbreak module G' to denote the possible genetic composition of the outbreak.

Other types and configurations of outbreak modules and participants modules can be used in other embodiments.

In conjunction with the characterization process, various reports can be generated by the submatrix processor **2804** and possibly presented to a client via a GUI of the system. Such reports can illustrate the abundance matrix partitions resulting from the biclustering algorithm or other type of abundance matrix partitioning algorithm. For example, a heat map can be generated in which the matrix entries are represented by colors with the color of each matrix entry being consistent with the corresponding abundance value of that entry so as to highlight the partitioned submatrices and their associated participants module and outbreak module. Additionally or alternatively, the participants module can be projected on a map displayed within the GUI, showing where the diseased patients are located.

As mentioned previously, certain designated alignment histogram characteristics such as depth can be used as the abundance measure utilized in generating the abundance vectors. Numerous other types and arrangements of information derived from the alignment histograms, including one or more of depth, coverage and integral, as well as additional or alternative metrics not necessarily based on alignment histograms, can also be used to generate abundance vectors utilizing the techniques disclosed herein.

FIG. **29** shows an example of a BED file utilized in conjunction with the read mapping and histogram generation processes described above. As mentioned previously, the BED file illustratively represents an output of the Cloud Burst mapping algorithm used in the read mapping block **2116** of FIGS. **21** and **22**, and an input to the abundance vector generator. Each line in the BED file represents a hit of a particular read from the sample on one of the gene units in the gene unit database. For example, as illustrated, the BED file in this embodiment includes a reference gene unit identifier, a starting offset in the reference, an ending offset in the reference, a read number, and an indication of the number of mismatches in the alignment. This particular read mapping file format is presented by way of example only, and numerous other formats can be used in other embodiments.

As mentioned previously, some embodiments implement surveillance functionality utilizing a combination of distributed ecogenome monitoring and characterization with distributed epidemiological interpretation. The illustrative embodiment of FIG. **4** is an example of such an arrangement.

In these and other embodiments involving distributed epidemiological interpretation, transmission trees may be used.

FIG. **30** shows a transmission graph **3000** for use in conjunction with distributed epidemiological interpretation

in an illustrative embodiment. Such a graph may be utilized, for example, in block **420** of the FIG. **4** embodiment, or in other embodiments involving utilization of an epidemiologic comparison component.

The transmission graph **3000** is an example of what is more generally referred to herein as an “epidemiological graph.” In the embodiment illustrated, each node of the transmission graph **3000** corresponds to a different biological sample (“S”) and a directed edge from one node to another node within the transmission graph is indicative of an epidemiological relationship between those two nodes. For example, a directed edge from one node to another node may be an indication of infection. The directed edges are illustratively weighted using respective weights (“W”) that further characterize the strength of the relationship between the corresponding pair of nodes within the transmission graph. The weights are also referred to as respective sample-to-sample comparison scores.

A transmission graph of the type illustrated in FIG. **30** can be used to provide a wide variety of different types of surveillance functionality. For example, such a graph can be utilized to characterize spread of a disease, infection or contamination, and to support functions such as identification of impacted communities via contact tracing, computation of hubs and super-spreaders, generation of outbreak spread predictions, generation of risk ranking decisions, and many others.

In some embodiments, a transmission graph such as transmission graph **3000** represents an example of a global epidemiological graph generated utilizing a plurality of local epidemiological graphs provided by different sequencing centers. Such a global epidemiological graph can be used to provide global view information to a client as previously described in conjunction with the embodiment of FIG. **5**. Other types of graphs can be used in a given embodiment. For example, a global epidemiological graph in some embodiments may alternatively comprise a phylogenetic tree in which the biological samples correspond to respective leaf nodes that are hierarchically clustered within the phylogenetic graph. As mentioned previously, the term “graph” as used herein is intended to be broadly construed.

Additional examples of graphs that can be used in illustrative embodiments include directed acyclic graphs, also referred to as phylogenetic networks. For example, such a graph can be used to model the evolution of a “super clone” outbreak via horizontal transfer of virulent gene units. The phylogenetic network allows both horizontal and vertical transfer of gene units to be effectively modeled. It should be noted that trees referred to in certain illustrative embodiments herein can in other embodiments be replaced with phylogenetic networks or other types of network or graph arrangements. For example, outbreak trees can in other embodiments be replaced with outbreak networks.

Transmission trees, phylogenetic trees and other similar tree, network or graph structures referred to herein are illustratively utilized in conjunction with provision of analytics processing or other types of surveillance functionality within a given system. For example, the surveillance functionality may be configured to provide topological queries on a global epidemiological graph formed using multiple local epidemiological graphs provided by respective geographically-distributed sequencing centers.

Each individual sequencing center in such an arrangement generally has only limited visibility of the global epidemiological graph. For example, a given sequencing center may only have a view of respective local portions of the graph relating to gene units in its local gene unit database. How-

ever, as noted above, global view information comprising substantially the entire global epidemiological graph can be provided as part of the surveillance functionality offered to a client. Such arrangements can be configured in some embodiments to protect the privacy of the sequencing centers in at least portions of the local information utilized in generating their respective local graphs.

Illustrative embodiments can provide a number of significant advantages relative to conventional arrangements.

For example, some embodiments provide metagenomics-based biological surveillance systems that are faster and more accurate than conventional biological surveillance systems. Moreover, metagenomics-based biological surveillance systems in some embodiments are implemented in a decentralized and privacy-preserving manner. These and other metagenomics-based biological surveillance systems advantageously overcome disadvantages of conventional practice, which as indicated previously often relies primarily on culture-based isolation sequencing and furthermore fails to provide mechanisms for coordinated processing over multiple geographically-distributed sequencing facilities.

Such arrangements are highly useful in providing rapid detection and control of geographically-dispersed waterborne or food-borne diseases, infections or contaminations that may be accelerated due to climate change, as well as in numerous other contexts, such as other contexts relating to public health, vaccine development, clinical diagnosis and treatment of patients, and product safety and compliance. For example, global warming is extending the geographic range of mosquitoes and ticks that harbor and transmit infectious diseases, resulting in outbreaks of malaria, dengue and yellow fever in new locations. In addition, due to its disastrous effect on local agricultural produce as well as weather-induced disasters such as river flooding, climate change is causing mass migration, leading to increased population density, not only of humans, but of disease vectors like rodents and skin parasites that carry pathogenic viruses and bacteria. These factors, along with poor sanitation, malnutrition, lack of access to vaccines, and exposure to contaminated water and food have created a favorable setting for the emergence and transmission of infectious diseases. Metagenomics-based surveillance functionality as disclosed herein advantageously helps to combat these and other emerging issues relating to global warming and climate change.

A metagenomics-based surveillance system in an illustrative embodiment can utilize the data scattered across multiple sequencing centers located worldwide, while preserving data privacy and adjusting for genome plasticity.

The use of WWH nodes in some embodiments leverages one or more frameworks supported by Hadoop YARN, such as MapReduce, Spark, Hive, MPI and numerous others, to support distributed computations while also minimizing data movement, adhering to bandwidth constraints in terms of speed, capacity and cost, and satisfying security policies as well as policies relating to governance, risk management and compliance.

It is to be appreciated that the particular types of system features and functionality as illustrated in the drawings and described above are exemplary only, and numerous other arrangements may be used in other embodiments.

It was noted above that portions of an information processing system as disclosed herein may be implemented using one or more processing platforms. Illustrative embodiments of such platforms will now be described in greater detail. These and other processing platforms may be used to implement at least portions of other information processing

systems in other embodiments of the invention. A given such processing platform comprises at least one processing device comprising a processor coupled to a memory.

One illustrative embodiment of a processing platform that may be used to implement at least a portion of an information processing system comprises cloud infrastructure including virtual machines implemented using a hypervisor that runs on physical infrastructure. The cloud infrastructure further comprises sets of applications running on respective ones of the virtual machines under the control of the hypervisor. It is also possible to use multiple hypervisors each providing a set of virtual machines using at least one underlying physical machine. Different sets of virtual machines provided by one or more hypervisors may be utilized in configuring multiple instances of various components of the system.

These and other types of cloud infrastructure can be used to provide what is also referred to herein as a multi-tenant environment. One or more system components such as processing nodes **102** and metagenomics sequencing centers **104**, or portions thereof, can be implemented as respective tenants of such a multi-tenant environment.

In some embodiments, the cloud infrastructure additionally or alternatively comprises a plurality of containers implemented using container host devices. For example, a given container of cloud infrastructure illustratively comprises a Docker container or other type of LXC. The containers may be associated with respective tenants of a multi-tenant environment of the system **100**, although in other embodiments a given tenant can have multiple containers. The containers may be utilized to implement a variety of different types of functionality within the system **100**. For example, containers can be used to implement respective cloud compute nodes or cloud storage nodes of a cloud computing and storage system. The compute nodes or storage nodes may be associated with respective cloud tenants of a multi-tenant environment of system **100**. Containers may be used in combination with other virtualization infrastructure such as virtual machines implemented using a hypervisor.

Another illustrative embodiment of a processing platform that may be used to implement at least a portion of an information processing system comprises a plurality of processing devices which communicate with one another over at least one network. The network may comprise any type of network, including by way of example a global computer network such as the Internet, a WAN, a LAN, a satellite network, a telephone or cable network, a cellular network, a wireless network such as a WiFi or WiMAX network, or various portions or combinations of these and other types of networks.

As mentioned previously, some networks utilized in a given embodiment may comprise high-speed local networks in which associated processing devices communicate with one another utilizing PCIe cards of those devices, and networking protocols such as InfiniBand, Gigabit Ethernet or Fibre Channel.

Each processing device of the processing platform comprises a processor coupled to a memory. The processor may comprise a microprocessor, a microcontroller, an application-specific integrated circuit (ASIC), a field-programmable gate array (FPGA) or other type of processing circuitry, as well as portions or combinations of such circuitry elements. The memory may comprise random access memory (RAM), read-only memory (ROM) or other types of memory, in any combination. The memory and other memories disclosed herein should be viewed as illustrative

examples of what are more generally referred to as “processor-readable storage media” storing executable program code of one or more software programs.

Articles of manufacture comprising such processor-readable storage media are considered embodiments of the present invention. A given such article of manufacture may comprise, for example, a storage array, a storage disk or an integrated circuit containing RAM, ROM or other electronic memory, or any of a wide variety of other types of computer program products. The term “article of manufacture” as used herein should be understood to exclude transitory, propagating signals.

Also included in the processing device is network interface circuitry, which is used to interface the processing device with the network and other system components, and may comprise conventional transceivers.

Again, these particular processing platforms are presented by way of example only, and other embodiments may include additional or alternative processing platforms, as well as numerous distinct processing platforms in any combination, with each such platform comprising one or more computers, servers, storage devices or other processing devices.

It should therefore be understood that in other embodiments different arrangements of additional or alternative elements may be used. At least a subset of these elements may be collectively implemented on a common processing platform, or each such element may be implemented on a separate processing platform.

Also, numerous other arrangements of computers, servers, storage devices or other components are possible in an information processing system as disclosed herein. Such components can communicate with other elements of the information processing system over any type of network or other communication media.

As indicated previously, components of an information processing system as disclosed herein can be implemented at least in part in the form of one or more software programs stored in memory and executed by a processor of a processing device. For example, at least portions of the functionality of a given metagenomics sequencing center or worldwide data node in a particular embodiment are illustratively implemented in the form of software running on respective processing devices.

It should again be emphasized that the above-described embodiments of the invention are presented for purposes of illustration only. Many variations and other alternative embodiments may be used. For example, the disclosed techniques are applicable to a wide variety of other types of information processing systems, processing and storage platforms, biological surveillance systems, processing nodes, sequencing centers, sample sources and other components. Also, the particular configurations of system and device elements, associated processing operations and other functionality illustrated in the drawings can be varied in other embodiments. Moreover, the various assumptions made above in the course of describing the illustrative embodiments should also be viewed as exemplary rather than as requirements or limitations of the invention. Numerous other alternative embodiments within the scope of the appended claims will be readily apparent to those skilled in the art.

What is claimed is:

1. A method comprising:
 - configuring a first processing node for communication with one or more additional processing nodes and with

one or more of a plurality of geographically-distributed metagenomics sequencing centers via one or more networks;

processing metagenomics sequencing results obtained from one or more of the metagenomics sequencing centers in the first processing node; and

providing surveillance functionality relating to at least one designated biological issue on behalf of one or more requesting clients based at least in part on the processing of metagenomics sequencing results performed by the first processing node and related processing performed by one or more of the additional processing nodes;

wherein each of the metagenomics sequencing centers is configured to perform metagenomics sequencing on biological samples from respective sample sources in a corresponding data zone;

wherein processing the metagenomics sequencing results further comprises generating a hit abundance score vector for a given one of the biological samples wherein the hit abundance score vector comprises a plurality of entries corresponding to respective occurrence frequencies of at least one read of the given biological sample in respective target genomic sequences;

wherein providing surveillance functionality further comprises:

performing a preprocessing operation to reduce a biclustering sample space of a genomic comparison component;

generating a hit abundance score matrix for the genomic comparison component comprising a plurality of the hit abundance score vectors wherein one of rows and columns of the hit abundance score matrix correspond to respective different ones of the biological samples and the other of the rows and columns of the hit abundance score matrix correspond to respective different ones of the target genomic sequences; and

performing a biclustering operation on the hit abundance score matrix; and

wherein the method is implemented by at least one processing device comprising a processor coupled to a memory.

2. The method of claim 1 wherein each of at least a subset of the processing nodes comprises at least one worldwide data node configured to perform operations in accordance with at least one supported framework of a YARN cluster on one or more corresponding portions of the metagenomics sequencing results.

3. The method of claim 1 wherein the sample sources comprise one or more of water sources, food sources, agricultural sources and clinical sources.

4. The method of claim 1 wherein the surveillance functionality relating to at least one designated biological issue comprises characterization of at least one of a disease, an infection and a contamination.

5. The method of claim 4 wherein the characterization of at least one of a disease, an infection and a contamination comprises characterizing said disease, infection or contamination as involving genomic material from multiple ones of the biological samples sequenced by different ones of the metagenomics sequencing centers.

6. The method of claim 1 wherein the processing of the metagenomics sequencing results in the first processing node comprises determining if genomic material in the metagenomics sequencing results is present in one or more known genomes.

7. The method of claim 1 wherein the metagenomics sequencing results for a given one of the biological samples comprises a complete sequencing of the biological sample performed without utilization of a culture-based pathogen isolation process.

8. The method of claim 7 wherein the complete sequencing of the biological sample comprises a set of reads for all organisms in the sample.

9. The method of claim 1 wherein the metagenomics sequencing results for a given one of the biological samples comprises a subset of reads for the given biological sample that are determined to match existing reads from other samples.

10. The method of claim 1 wherein the metagenomics sequencing results for a given one of the biological samples comprises a subset of reads for the given biological sample that excludes any reads that match a human genome.

11. The method of claim 1 wherein performing a biclustering operation on the hit abundance score matrix comprises processing the hit abundance score matrix in the form of a bipartite graph in which a first set of nodes represents respective ones of the biological samples, a second set of nodes represents respective ones of the target genomic sequences, and edges between nodes in the first set and nodes in the second set represent hit abundance scores of the hit abundance score vectors of the hit abundance score matrix.

12. A computer program product comprising a non-transitory processor-readable storage medium having stored therein program code of one or more software programs, wherein the program code when executed by at least one processing device causes said at least one processing device:

to configure a first processing node for communication with one or more additional processing nodes and with one or more of a plurality of geographically-distributed metagenomics sequencing centers via one or more networks;

to process metagenomics sequencing results obtained from one or more of the metagenomics sequencing centers in the first processing node; and

to provide surveillance functionality relating to at least one designated biological issue on behalf of one or more requesting clients based at least in part on the processing of metagenomics sequencing results performed by the first processing node and related processing performed by one or more of the additional processing nodes;

wherein each of the metagenomics sequencing centers is configured to perform metagenomics sequencing on biological samples from respective sample sources in a corresponding data zone;

wherein processing the metagenomics sequencing results further comprises generating a hit abundance score vector for a given one of the biological samples wherein the hit abundance score vector comprises a plurality of entries corresponding to respective occurrence frequencies of at least one read of the given biological sample in respective target genomic sequences; and

wherein providing surveillance functionality further comprises:

performing a preprocessing operation to reduce a biclustering sample space of a genomic comparison component;

generating a hit abundance score matrix for the genomic comparison component comprising a plurality of the hit abundance score vectors wherein one of rows and

columns of the hit abundance score matrix correspond to respective different ones of the biological samples and the other of the rows and columns of the hit abundance score matrix correspond to respective different ones of the target genomic sequences; and performing a biclustering operation on the hit abundance score matrix.

13. The computer program product of claim 12 wherein each of at least a subset of the processing nodes comprises at least one worldwide data node configured to perform operations in accordance with at least one supported framework of a YARN cluster on one or more corresponding portions of the metagenomics sequencing results.

14. The computer program product of claim 12 wherein the surveillance functionality relating to at least one designated biological issue comprises characterization of at least one of a disease, an infection and a contamination.

15. The computer program product of claim 12 wherein performing a biclustering operation on the hit abundance score matrix comprises processing the hit abundance score matrix in the form of a bipartite graph in which a first set of nodes represents respective ones of the biological samples, a second set of nodes represents respective ones of the target genomic sequences, and edges between nodes in the first set and nodes in the second set represent hit abundance scores of the hit abundance score vectors of the hit abundance score matrix.

16. An apparatus comprising:

a first processing node configured for communication with one or more additional processing nodes and with one or more of a plurality of geographically-distributed metagenomics sequencing centers via one or more networks;

the first processing node being further configured: to process metagenomics sequencing results obtained from one or more of the metagenomics sequencing centers; and

to provide surveillance functionality relating to at least one designated biological issue on behalf of one or more requesting clients based at least in part on the processing of metagenomics sequencing results performed by the first processing node and related processing performed by one or more of the additional processing nodes;

wherein each of the metagenomics sequencing centers is configured to perform metagenomics sequencing on biological samples from respective sample sources in a corresponding data zone; and

wherein the first processing node is implemented using at least one processing device comprising a processor coupled to a memory;

wherein processing the metagenomics sequencing results further comprises generating a hit abundance score vector for a given one of the biological samples wherein the hit abundance score vector comprises a plurality of entries corresponding to respective occurrence frequencies of at least one read of the given biological sample in respective target genomic sequences; and

wherein providing the surveillance functionality further comprises:

performing a preprocessing operation to reduce a biclustering sample space of a genomic comparison component;

generating a hit abundance score matrix for the genomic comparison component comprising a plurality of the hit abundance score vectors wherein one of rows and

columns of the hit abundance score matrix correspond to respective different ones of the biological samples and the other of the rows and columns of the hit abundance score matrix correspond to respective different ones of the target genomic sequences; and performing a biclustering operation on the hit abundance score matrix. 5

17. The apparatus of claim **16** wherein each of at least a subset of the processing nodes comprises at least one worldwide data node configured to perform operations in accordance with at least one supported framework of a YARN cluster on one or more corresponding portions of the metagenomics sequencing results. 10

18. The apparatus of claim **16** wherein the surveillance functionality relating to at least one designated biological issue comprises characterization of at least one of a disease, an infection and a contamination. 15

19. A metagenomics-based biological surveillance system comprising the apparatus of claim **16**.

20. The apparatus of claim **16** wherein performing a biclustering operation on the hit abundance score matrix comprises processing the hit abundance score matrix in the form of a bipartite graph in which a first set of nodes represents respective ones of the biological samples, a second set of nodes represents respective ones of the target genomic sequences, and edges between nodes in the first set and nodes in the second set represent hit abundance scores of the hit abundance score vectors of the hit abundance score matrix. 20 25

* * * * *