



US 20040156564A1

(19) **United States**

(12) **Patent Application Publication**
Glasser

(10) **Pub. No.: US 2004/0156564 A1**

(43) **Pub. Date: Aug. 12, 2004**

(54) **EASY-OPENING SYSTEM FOR
DRAWSTRING BAGS**

Related U.S. Application Data

(76) Inventor: **Jerome Glasser**, Maplewood, NJ (US)

(60) Provisional application No. 60/398,129, filed on Jul. 25, 2002.

Correspondence Address:
JEROME GLASSER
16 SUNSET TERRACE
MAPLEWOOD, NJ 07040 (US)

Publication Classification

(51) **Int. Cl.⁷ B65D 33/28**

(52) **U.S. Cl. 383/72; 383/73**

(21) Appl. No.: **10/627,060**

(57) **ABSTRACT**

(22) Filed: **Jul. 25, 2003**

At least one graspable element is attached substantially at the main aperture of a drawstring bag, thereby affording a superior, more comfortable bag-opening experience in comparison to that of traditional drawstring bags.

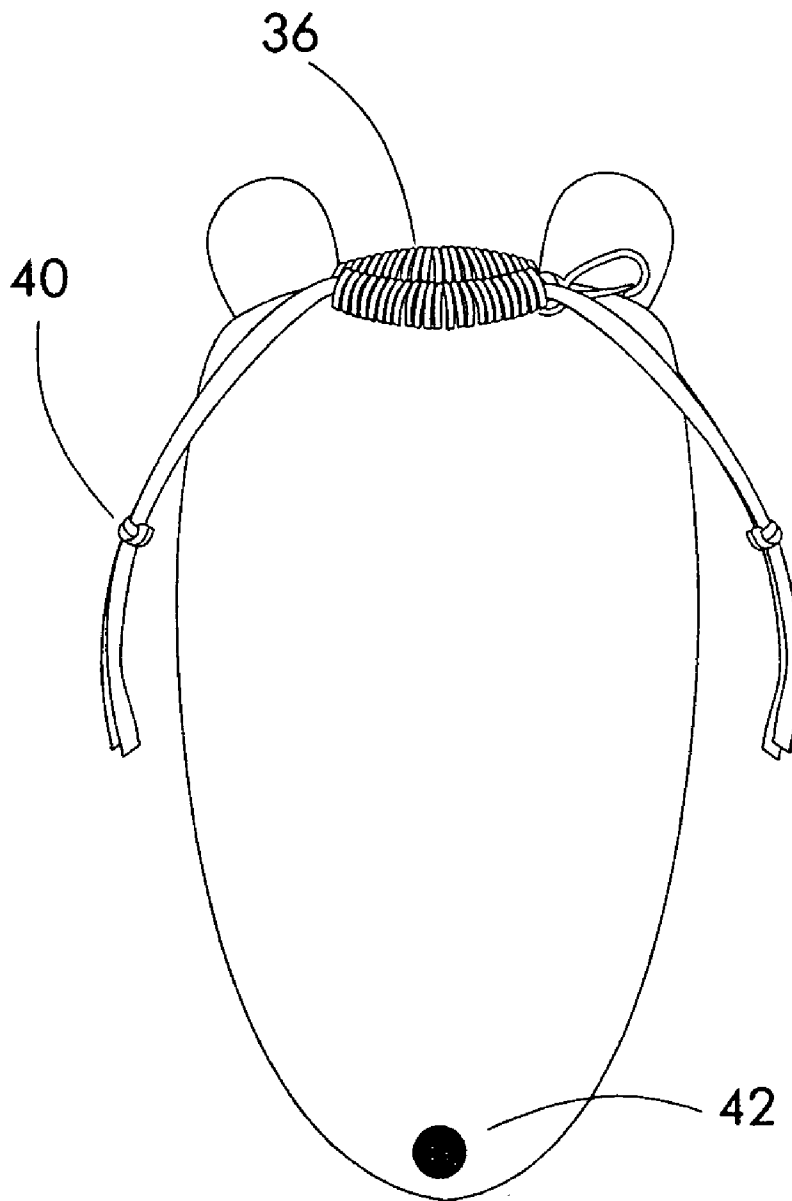

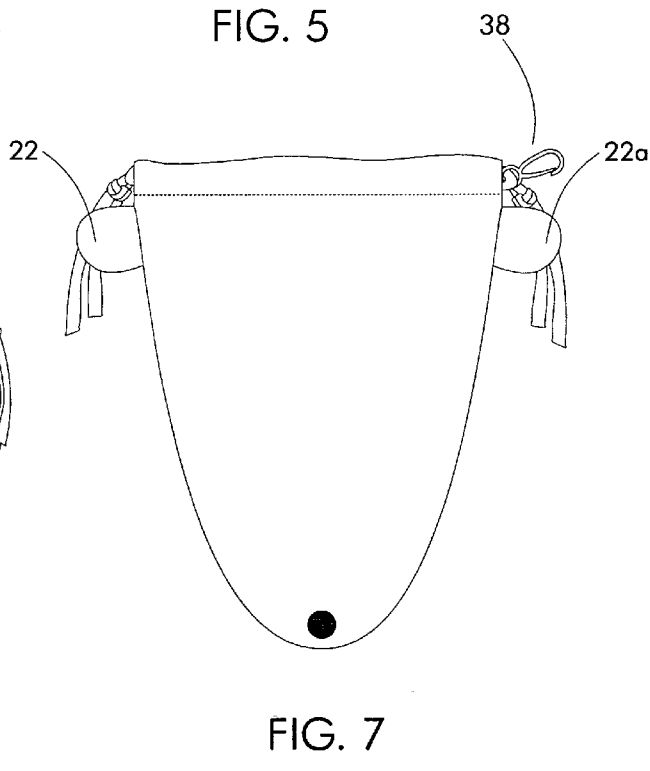
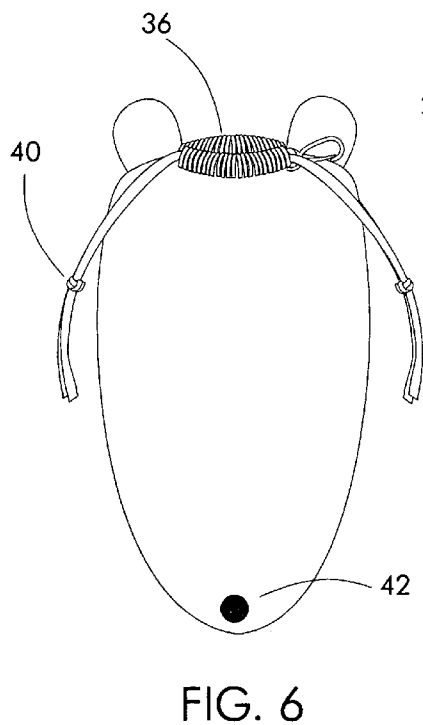
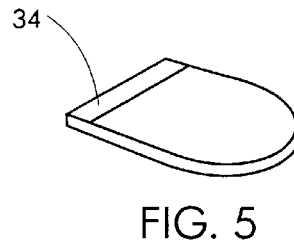
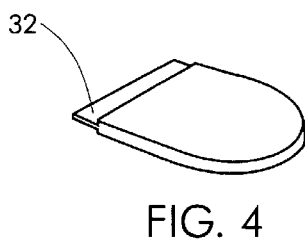
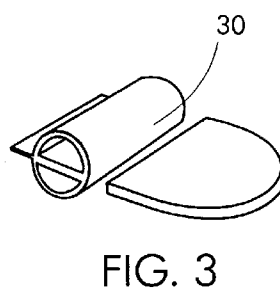
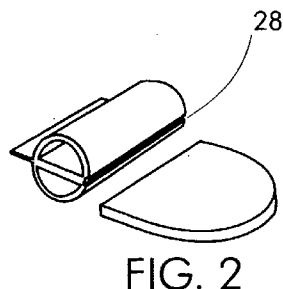
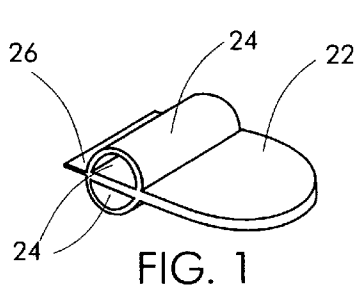

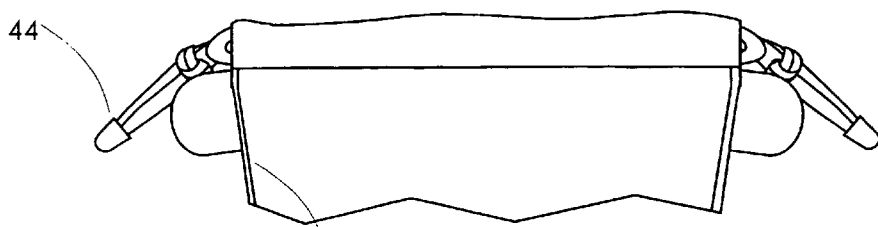

FIG. 8

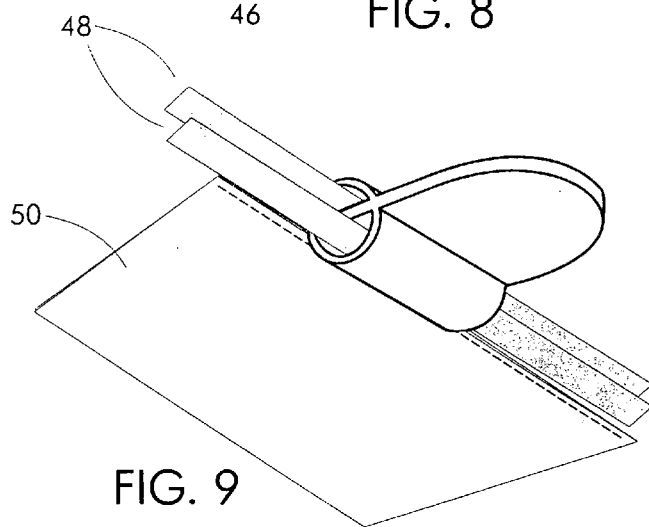

FIG. 9

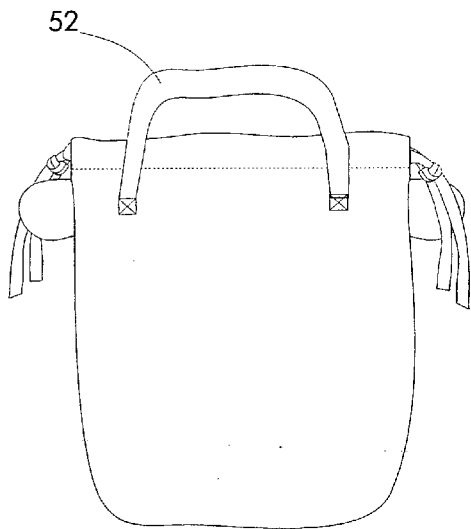

FIG. 10

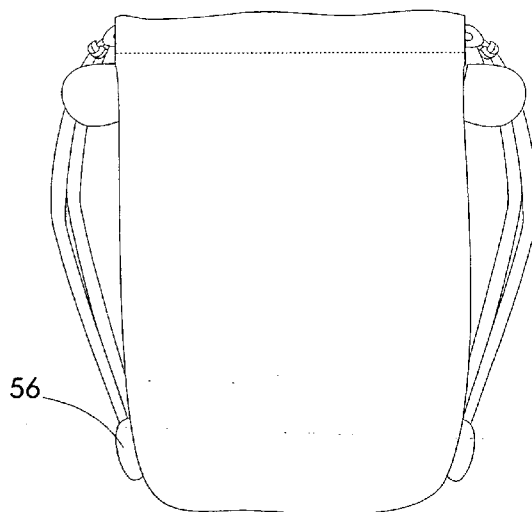

FIG. 11

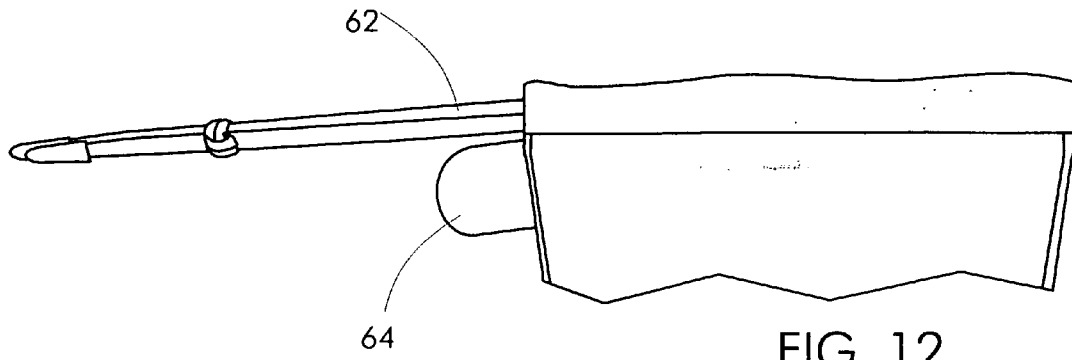

FIG. 12

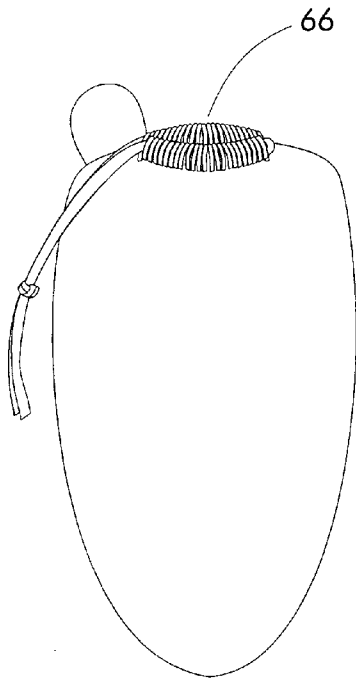

FIG. 13

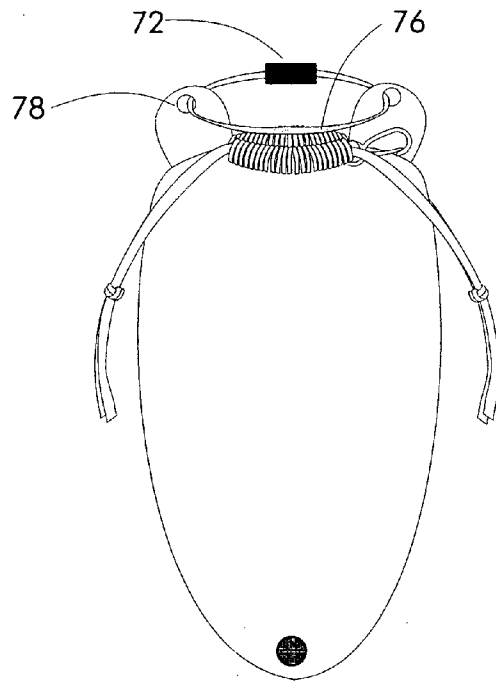

FIG. 14

EASY-OPENING SYSTEM FOR DRAWSTRING BAGS

FIELD OF THE INVENTION

[0001] The present invention relates to devices for opening and closing bags.

BACKGROUND OF THE INVENTION

[0002] This Non-Provisional Patent Application is based on Provisional Patent Application No. 60/398,129 filed Jul. 25, 2002. There is a need for an enhanced means for opening a drawstring bag. The means for closing this type of bag are well-known in the art and are relatively easy for the average user to operate: The drawstring(s) of a conventional bag simply is/are grasped, and one side of the "neck" of the bag aperture is forced to meet the other side as closely as possible. By so doing, the neck of the aperture is easily constricted and closed.

[0003] Unlike the closing operation, however, the means for opening the simple and usually inexpensively produced drawstring bag, are rather difficult and cumbersome. Until the disclosure of the system of this invention, the few opening methods for this style of bag have been well known in the art because they are extremely elemental. All have the drawback, however, that, while ultimately functional, the opening experience is not the most comfortable one possible.

[0004] Traditionally, a user attempts to open a closed drawstring bag by forcing at least one index finger, and usually both, into the tightly compressed middle of the constricted aperture of the bag. Then begins the strenuous effort of prying apart the bag's bunched material by moving hands in opposite directions away from each other. The primary disadvantage with the traditional means for opening a conventional drawstring bag is as follows: When the bag is in the closed position, the aperture-constricting element, usually a string or cord located around the circumference, about the "neck" of the bag's aperture, is, naturally, most often drawn very tightly. This serves to crimp the aperture in an attempt to best ensure that the contents of the bag are prevented from spilling out. Consequently, the a task of trying to wedge fingers into this tightly constricted aperture most often requires the exertion of a significant force. In many cases it even requires excessive force, which can lead to carpal-tunnel causing strains, or, particularly in the case of women, to an even more calamitous event: finger nail breakage. Forcing one's digits into a tightly constricted neck, certainly is not as simple, easy and comfortable an opening action as, for example, the operation of Velcro™ or a traditional zipper.

[0005] Nevertheless, prior art opening methods have remained unchanged and unenhanced since the first production of drawstring containers and bags. Perhaps the main reason that few enhancements have rarely, if ever, been made to the opening system for drawstring bags is that the simple and inexpensive general nature of the bag does not invite innovation. Historically, the contention among drawstring bag manufacturers has been that any improvements incorporated into the manufacturing process would likely increase production costs. Manufacturers have felt that any research and development costs could not be justified for the simple, drawstring-type bag which is designed to be sold

inexpensively. There has been yet another important factor that has inhibited developmental enhancements to the drawstring bag. Retail store buyers' fear of the potential for their end-user consumers to be confused by the requirement for learning to operate a new opening system is another barrier to drawstring bag innovation. The fear of conceivably confusing the end-using consumers and thereby making the traditional-style drawstring bag less desirable to purchase, has removed the demand by bag retailers to invite drawstring bag manufacturers to innovate. Moreover, since drawstring bags in the past have not been designed to be lockable, furthermore, significantly less attention has been given to the use and operation of drawstring bags than other types of bags.

[0006] The invention disclosed herein affords users a more comfortable means for opening a drawstring bag by providing a graspable opening system which may include a tab-like, handle or handles. These tabs, which may also display brand indicia, are designed to be easily gripped and pulled apart—in directions opposite to one another. Since, in a preferred embodiment, the handles are attached substantially around the "neck" area of the drawstring bag, they offer leverage in the opening process and remove the need for users to wedge fingers into constricted bag apertures.

[0007] The easy-opening system for drawstring bags affords easy grasping for the hands when it is desirable to open a drawstring bag. These and other objects and advantages of the invention will become more apparent from the following detailed description and claims.

SUMMARY AND OBJECTS OF THE INVENTION

[0008] The present invention is a system which improves the ease-of-opening process for a drawstring bag.

[0009] An object of this invention is to provide an opening system which offers handle-like elements which can be easily grasped in order to facilitate the opening of a closed drawstring bag.

[0010] Another object of this invention is to provide an opening system which is relatively simple and inexpensive to manufacture, and also to incorporate into a drawstring bag's construction.

[0011] Yet still another object of this invention is to provide an opening system which is suitable for displaying messages such as trademark indicating indicia.

[0012] Yet still another and further object of this invention is to provide an opening system which can offer the extra value as to function as part of a locking system for a drawstring bag.

[0013] Yet another, further object of this invention is to produce a system which, if so desired could be adapted to be impregnable with scent in order to afford a pleasant aroma to the drawstring bag over a prolonged period of time.

[0014] Yet still another, further object of this invention is to provide a packaging format that includes a vapor-barrier properties which can substantially contain a scent trapped within the packaging until product use is desired.

BRIEF DESCRIPTION OF THE DRAWINGS

[0015] FIG. 1 is a side view of a tab that has built-in cord-channels that are integrally molded with the tab;

- [0016] FIG. 2 is a side view of a cord-channel that has a ridge into which a tab may be glued or sonically-welded;
- [0017] FIG. 3 is a side view of a cord-channel with no ridge onto which a tab may be glued or sonically-welded;
- [0018] FIG. 4 is a side view of a tab that has a thinner section that a sewing needle may more easily penetrate;
- [0019] FIG. 5 is a side view of a tab that is of a uniform thickness;
- [0020] FIG. 6 is a frontal view of a closed bag with a rounded end and an air hole vent;
- [0021] FIG. 7 is a frontal view of an opened bag with a rounded end and an air hole vent;
- [0022] FIG. 8 is a cutaway frontal view of an opened bag having plastic end clips;
- [0023] FIG. 9 is a side view of a tab having built-in cord-channels which is sewn into the bag material and having inserted cords;
- [0024] FIG. 10 is a frontal view of an opened bag with sewn-in handles;
- [0025] FIG. 11 is a frontal view of an opened bag with means to attach cord ends to the bag body;
- [0026] FIG. 12. is a cutaway frontal view of an opened bag with only one drawstring and tab handle;
- [0027] FIG. 13. is a frontal view of a closed version of FIG. 12;
- [0028] FIG. 14. is a frontal view of a locking system which can be incorporated into the opening system.

-
- Tab 22
 - Tab 22a
 - Cord-Channel 24
 - Cord-Channel Ridge 26
 - Cord-Channels Insertion Ridge 28
 - Ridgeless Cord-Channel 30
 - Tab Ridge 32
 - Ridgeless Tab 34
 - Closed Bag Neck 36
 - Bag Clip 38
 - Cord Knot 40
 - Air Vent 42
 - Cord End Clips 44
 - Bag Seam 46
 - Cords 48
 - Bag Material 50
 - Bag Handles 52
 - Cord Tip Securing Tabs 56
 - Single Cord 62
 - Single Integral Tab 64
 - Closed Aperture Bag Neck 66
 - Locking Mechanism 72
 - Securing Lock-Cord 76
 - Tab Hole 78
-

DESCRIPTION OF THE PREFERRED EMBODIMENT

[0029] The most common construction of a drawstring bag, the typical preferred embodiment, takes the form of a substantially square or rectangular piece of fabric folded in half to form a rectangular or square shape; and after this fold,

at least one seam 46 is sewn on each side of the folded material. These two side-seams 46 provide for the creation of a material “envelope” which constitutes the “body” of the bag. The “top” or “neck” of the bag defines an open, as yet unsewn side.

[0030] Along each of the open, unstitched edges of the bag neck a “downwards” fold is made in the material. These folds can be approximately 1 inch from the top edge of each “side” the material of the neck. These folds are sewn in order to form a tubular canal through which a constricting elements, Cords 48 or Single Cord 62 may be drawn. This/ These constricting element(s) is/are slidably disposed within the tubular canal and are integral to the closing process for a drawstring bag. This is commonly known to those skilled in the art.

[0031] Prior to molding or extruding some prospective elements of the system of this invention, such as Tab 22, a traditional, common, conventional plastic pelletized resin is obtained. This information is also well known to one skilled in the art. If a scent is desired to be imparted to Tab 22, an essential oil-impregnated resin is obtained and then fed into a conventional molding machine. The one utilizable plastic is a 50% PVC. This material is strong enough to withstand ripping away from Bag Material 50 when subjected to the pressure of being pulled by human hands, and yet, if Tab 22 is to be sewn to the body of the bag, soft enough to permit conventional sewing needles to puncture its body. In this case, the thickness of Tab 22 should be about 1-2 mm. Of course, a thicker Tab 22 may be used if the tab will be glued instead of sewn when attached to Bag Material 50. If sewn, Tab 22 should be sewn as close to the neck of the bag as possible in order to provide the greatest amount of leverage towards opening a closed bag, which is usually closed very tightly. When opening the bag of the preferred embodiment having two graspable handles, Tab 22 and Tab 22a, flanking the sides of Bag Seams 46, and located essentially adjacent to Closed Bag Neck 36 are grasped, and pressure is then applied in opposing directions to move Tabs 22 and 22a away and apart from each other. In so doing, Closed Bag Neck 36, must necessarily open since Bag Material 50 is attached to Tabs 22 and 22a.

[0032] By inserting Cords 48 into Cord-Channels 24 on either side of one version of Tabs 22, it is possible to reduce the chances for the Cords 48 and, consequently, Cord End Clips 44 to flail about uncontrollably. The Cords 48 should be at least as long and preferably at least slightly longer than the circumference of the tubular envelope around the neck of the drawstring bag. Bag Clip 38 is used to allow two bags to be separable if separation is desired when they are clipped together. Air Vent 42 is useful for allowing air to penetrate a bag. This is particularly relevant to shoe-holding bags.

[0033] Cord Tip Securing Tabs 56 are primarily decorative, however, they can prevent scratching of clothing and skin. Single Cord 62 represents one cord only, as opposed to the two-cord closure method of the preferred embodiment. Likewise, Single Integral Tab 64 discloses an alternate embodiment using only one single Tab 22. Closed Aperture Bag Neck 66 features what the drawstring bag looks like when tightly closed. Locking Mechanism 72 represents any traditional lock means, and Securing Lock-Cord 76 demonstrates one preferred embodiment for preventing Tabs 22 and

22a from separating, thereby “locking” the drawstring bag. Tab Hole 78 is the aperture through which the locking mechanism may function.

[0034] When Tab 22 is molded, logos may be silk-screened, embossed or molded into its body. After the Tabs 22 molding process is completed and it is sewn or glued in place, the completed drawstring bag is overwrapped in a conventional fashion by any traditional plastic, or in a special case of scented materials, a film having vapor-barrier characteristics made of plastic or metallized packaging materials that will contain a fragrance preferably composed of a plastic polymer material such as EVOH™ which is extremely resistant to scent dissipation.

[0035] Disclosed FIGS. 1-5 illustrate some different methods of creating Tab 22; Tab 22 can be made with the tab section integrally produced with Cord Channel 24, or attached to Cord Channel 24 via Cord Channels Insertion Ridge 28. Cord Channel Ridge 26 is useful in the sewing or gluing process of Tab 22 to Bag Material 50. Alternatively, the primary body of Tab 22 may simply be welded in a sonic-welding format to Cord Channel 24 without any Cord Channels Insertion Ridge 28, as disclosed by Ridgeless Cord Channel 30. Simpler forms of Tab 22 are Tab Ridge 32 and Ridgeless Tab 34 which are designed to be either glued or sewn into Bag Material 50.

[0036] While the preferred embodiment of the present invention has been described and illustrated, it is understood by one skilled in the art that the preferred embodiment is capable of variation, addition, omission and modification without departing from the spirit and scope of the invention.

What is claimed is:

1. A system for opening a drawstring container comprising:

material constructed to form a container having at least one aperture;

a material-constricting element;

a means to hold said material-constricting element substantially around the circumference of said at least one aperture;

at least one graspable element having an outer surface constructed and arranged to be gripped by a user.

2. The system of claim 1, wherein:

said material is substantially planar;

said means to hold said material-constricting element substantially around the circumference of said at least one aperture is tube-like;

said material-constricting element is slidably disposed within said tube-like means to hold a material-constricting element;

said at least one graspable elements is integrally made from said container’s substantially planar material.

3. The system of claim 2, wherein:

said substantially planar material is pliable;

said means to hold said material-constricting element substantially around the circumference of said at least one aperture is a tube-like envelope of pliable material;

said material-constricting element is at least as long as the circumference of said container aperture.

4. The system of claim 3, wherein:

said substantially planar pliable material is synthetic textile fabric;

said means to hold said material-constricting element substantially around the circumference of said at least one aperture is a tubular envelope of pliable material constructed from the same material as that which forms the container itself;

said material-constricting element held substantially around the circumference of said at least one aperture and slidably disposed within said tube-like envelope of pliable material is longer than the circumference of said at least one aperture, so that it may be easily grasped.

5. The system of claim 4, wherein:

said substantially planar pliable material is natural;

said means to hold said material-constricting element substantially around the circumference of said at least one aperture is a tube-like envelope of pliable material constructed from at least one unconnected element of material to that which forms the container itself;

said material-constricting element held substantially around the circumference of said at least one aperture and slidably disposed within said tube-like envelope of pliable material is formed of a textile fabric.

6. The device of claim 5, wherein:

said substantially planar pliable material is natural, and suitable for conventional sewing;

said means to hold said material-constricting element substantially around the circumference of said at least one aperture is tubular loops of pliable material constructed from multiple, unconnected elements of material separate from that which forms the container itself;

said material-constricting element held substantially around the circumference of said at least one aperture and slidably disposed within said tubular envelope of pliable material is cord-like.

7. A system for opening a drawstring container comprising:

material constructed to form a container having at least one aperture;

a material-constricting element;

a means to hold said material-constricting element substantially around the circumference of said at least one aperture;

at least one graspable element having an outer surface constructed and arranged to be gripped by a user.

8. The system of claim 7, wherein:

said material is substantially planar;

said means to hold said material-constricting element substantially around the circumference of said at least one aperture is tube-like;

said material-constricting element is slidably disposed within said tube-like means to hold a material-constricting element;

said at least one graspable elements is made of material different from that of said container material.

9. The system of claim 8, wherein:

said substantially planar material is pliable;

said means to hold said material-constricting element substantially around the circumference of said at least one aperture is a tube-like envelope of pliable material;

said material-constricting element is at least as long as the circumference of said container aperture;

said graspable element is made of plastic.

10. The system of claim 9, wherein:

said substantially planar pliable material is synthetic textile fabric;

said means to hold said material-constricting element substantially around the circumference of said at least one aperture is a tubular envelope of pliable material constructed from the same material as that which forms the container itself;

said material-constricting element held substantially around the circumference of said at least one aperture and slidably disposed within said tube-like envelope of pliable material is longer than the circumference of said at least one aperture, so that it may be easily grasped;

said at least one graspable element having an outer surface constructed and arranged to be gripped by a user is made of plastic through an injection-molding process.

11. The system of claim 10, wherein:

said substantially planar pliable material is natural;

said means to hold said material-constricting element is a tube-like envelope of pliable material constructed from at least one unconnected element of material to that which forms the container itself;

said material-constricting element is formed of a textile fabric;

said graspable element is made of a plastic which can be impregnated with a scent.

12. A system for opening a drawstring container comprising:

material constructed to form a container having at least one aperture;

at least a first material-constricting element;

at least a second material constricting element;

a means to hold said material-constricting element substantially around the circumference of said at least one aperture;

at least one graspable element having an outer surface constructed and arranged to be gripped by a user;

at least a second graspable element having an outer surface constructed and arranged to be gripped by a user.

13. The device of claim 12, wherein:

said material is substantially planar;

said means to hold said material-constricting element substantially around the circumference of said at least one aperture is tube-like;

said first and second material-constricting elements are slidably disposed within said tube-like means to hold at least one material-constricting element;

said first and second graspable elements having outer surfaces constructed and arranged to be gripped by a user are integrally made from said container's substantially planar material.

14. The device of claim 13, wherein:

said substantially planar material is pliable;

said means to hold said material-constricting element substantially around the circumference of said at least one aperture is a tubular envelope of pliable material;

said material-constricting elements slidably disposed within said tubular envelope of pliable material are at least as long as the circumference of said at least one aperture;

said graspable element having an outer surface constructed and arranged to be gripped by a user is made of plastic.

said at least a second graspable element having an outer surface constructed and arranged to be gripped by a user is made of different material than that of said first graspable element;

said means for attaching said graspable elements to opposite sides of said at least one aperture is conventional sewing.

15. The device of claim 14, wherein:

said substantially planar pliable material is synthetic textile fabric;

said means to hold said material-constricting element is a tubular envelope of pliable material constructed from the same material as that which forms the container itself;

said material-constricting elements are longer than the circumference of said at least one aperture so that they may be easily grasped;

said graspable element having an outer surface constructed and arranged to be gripped by a user is made of plastic and through an injection-molding process.

16. The device of claim 15, wherein:

said substantially planar pliable material is natural;

said means to hold said material-constricting element is a tubular envelope of pliable material constructed from at least one unconnected element of material to that which forms the container itself;

said material-constricting elements are of fabric-like textile;

said graspable element having an outer surface constructed and arranged to be gripped by a user is natural;

said means for attaching said graspable elements to opposite sides of said at least one aperture is conventional sewing.

17. The device of claim 16, wherein:

said substantially planar pliable material is natural, suitable for conventional sewing;

said means to hold said material-constricting element is tubular loops of pliable material constructed from multiple, unconnected elements of material separate from that which forms the container itself;

said material-constricting element held substantially around the circumference of said at least one aperture and slidably disposed within said tubular envelope of pliable material is string-like;

said graspable element having an outer surface constructed and arranged to be gripped by a user is made of some form of metal;

said first and said at least a second graspable elements' at least one aperture suited to receive a conventional lock inserted therethrough;

said means for attaching said graspable elements to opposite sides of said at least one aperture is gluing.

18. The device of claim 17, wherein:

said substantially planar pliable material is natural, suitable for conventional sewing;

said means to hold said material-constricting element is a fabric envelope formed through sewing a fabric tunnel envelope from an integral edge of the material forming the outer edge of said pliable material of said container at the edge of said container aperture;

said material-constricting element is slightly longer than the circumference of said aperture and fabricated of pliable synthetic or natural cord;

said graspable elements having outer surface constructed and arranged to be gripped by a user are made of metal;

said first and said at least a second graspable elements' at least one aperture suited to receive a conventional lock inserted therethrough is reinforced to prevent damage to or destruction of said lock aperture;

said means for attaching said graspable elements to opposite sides of said at least one aperture is a combination of sewing and gluing.

19. The device of claim 18, wherein:

said substantially planar pliable material is natural, suitable for conventional sewing;

said means to hold said material-constricting element is a fabric envelope formed through sewing a fabric tunnel envelope from an integral edge of the material forming the outer edge of said pliable material of said container at the edge of said container aperture;

said material-constricting element is slightly longer than the circumference of said aperture and fabricated of pliable synthetic or natural cord;

said graspable elements having outer surface constructed and arranged to be gripped by a user are made of plastic and through an injection molding process suitable for having a scent impregnated within the plastic;

said first and said at least a second graspable elements' at least one aperture suited to receive a conventional lock inserted therethrough is reinforced to prevent damage to or destruction of said lock aperture;

said means for attaching said graspable elements to opposite sides of said at least one aperture is a combination of sewing and gluing.

* * * * *