

(19) World Intellectual Property Organization
International Bureau



(43) International Publication Date
28 March 2002 (28.03.2002)

PCT

(10) International Publication Number
WO 02/25035 A2

- (51) International Patent Classification⁷: **E04G**
- (21) International Application Number: PCT/US01/29741
- (22) International Filing Date: 21 September 2001 (21.09.2001)
- (25) Filing Language: English
- (26) Publication Language: English
- (30) Priority Data: 60/234,624 22 September 2000 (22.09.2000) US
- (71) Applicant: TOWER SOLUTIONS, INC. [US/US]; 1300 Holstein Drive, Pine City, MN 55063 (US).
- (72) Inventor: OLSEN, Steven, A.; 565 Crestview Lane, Owatonna, MN 55060 (US).
- (74) Agent: MARKS, Scott, A.; Dorsey & Whitney LLP, Pillsbury Center South, 220 South Sixth Street, Minneapolis, MN 55402-1498 (US).
- (81) Designated States (*national*): AE, AG, AL, AM, AT, AU, AZ, BA, BB, BG, BR, BY, BZ, CA, CH, CN, CO, CR, CU, CZ, DE, DK, DM, DZ, EC, EE, ES, FI, GB, GD, GE, GH, GM, HR, HU, ID, IL, IN, IS, JP, KE, KG, KP, KR, KZ, LC, LK, LR, LS, LT, LU, LV, MA, MD, MG, MK, MN, MW, MX, MZ, NO, NZ, PH, PL, PT, RO, RU, SD, SE, SG, SI, SK, SL, TJ, TM, TR, TT, TZ, UA, UG, UZ, VN, YU, ZA, ZW.
- (84) Designated States (*regional*): ARIPO patent (GH, GM, KE, LS, MW, MZ, SD, SL, SZ, TZ, UG, ZW), Eurasian patent (AM, AZ, BY, KG, KZ, MD, RU, TJ, TM), European patent (AT, BE, CH, CY, DE, DK, ES, FI, FR, GB, GR, IE, IT, LU, MC, NL, PT, SE, TR), OAPI patent (BF, BJ, CF,

[Continued on next page]

(54) Title: RETRACTABLE COLUMN AND METHOD OF FORMING

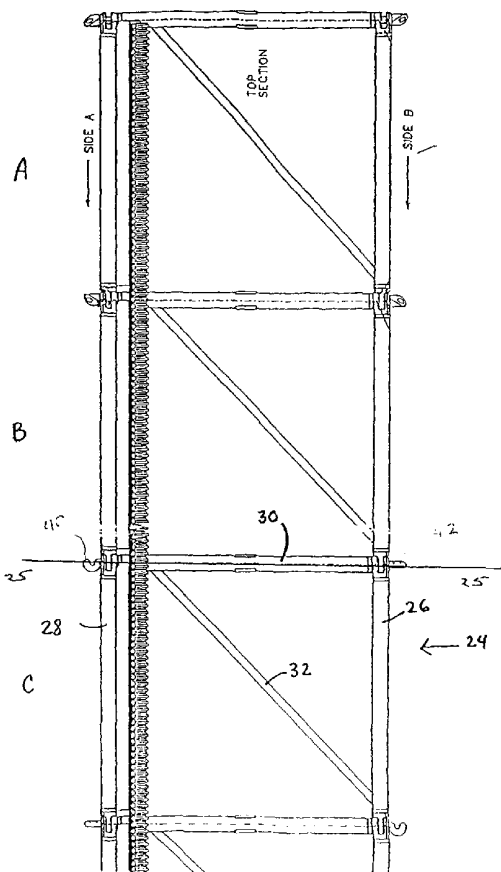

(57) Abstract: The present invention is an improved apparatus and method for forming a retractable tower or column. The present invention includes pointed hooks wherein the hooks are attached to each section of a section chains are placed on a take up mechanism in an operable position and then raised utilizing a motor. As the section chains are raised, they are guided by a guide tower, rollers, shims, and gear racks into a position whereby hooks from adjacent sections of the section chains form coupled engagements. The coupled engagement of the hooks of the sections of each adjacent section chains thereby from the column.

WO 02/25035 A2



CG, CI, CM, GA, GN, GQ, GW, ML, MR, NE, SN, TD, TG).

For two-letter codes and other abbreviations, refer to the "Guidance Notes on Codes and Abbreviations" appearing at the beginning of each regular issue of the PCT Gazette.

Published:

— *without international search report and to be republished upon receipt of that report*

RETRACTABLE COLUMN AND METHOD OF FORMING**PRIORITY**

This application claims the benefit of Provisional Application Serial No. 60/234,624, filed September 22, 2000.

5

FIELD OF THE INVENTION

This invention relates generally to support columns, and more specifically, to an improved retractable support column for use in supporting overhead structures that can be extended from a portable or fixed in place

10 platform.

BACKGROUND

Link structures that can be linked together to form a rigid structure are well known in the art. Structures of this kind may be used to form a platform to elevate a person or equipment, to form a bridge to permit a user to pass over an
15 obstacle, or to form a dock. Additionally, such structures have been used in space applications to extend a flexible sheet of material or to form a tower as a structure in space. See U.S. Patent Nos. 2,661,082, 3,397,546, 4,024,595, 4,089,147, and 4,237,662.

Retractable towers of this kind may be further utilized as a portable
20 telecommunications tower, wherein various sights can be tested without constructing a costly test tower at a location to discover it was not effective for the intended purpose. Retractable towers may also be used as a temporary lighting systems for sporting events, emergencies, or on ships. Other applications may also be present in a variety of other fields and a variety of other situations.

The formation of retractable columns has been previously described. U.S. Patent No. 4,920,710 to David L. Paine previously described a retractable support column for use in lifting and suspending overhead structures, which is herein incorporated by reference for everything it discloses. The structures that were formed using this apparatus and method, however, were subject to poor interconnection of the tower sections. The poor connection of the sides of the tower was caused in part by poor alignment of the section chains, and through the hooks, as the sides were raised. Poor alignment of the adjacent sections resulted in a poorly constructed tower; when a large amount of stress was placed on the poorly aligned tower, it sometimes resulted in the sheering of the pins holding the tower. The sheering of the pins resulted in a low structural integrity for the tower. These problems increased the difficulty in using towers systems of this type and also increased safety concerns and dangers.

Accordingly, there is a need for an improved retractable tower structure that provides greater structural integrity. There is a further need for a retractable tower which is more reliable, which provides a sturdier tower under adverse conditions, and which increases the load bearing characteristics of towers.

SUMMARY OF THE INVENTION

The present invention is an improved retractable tower which fills a variety of useful functions known in the art and which meets the needs in the art by providing greater stability and resistance to sheer caused by wind, ice, snow, and other adverse weather conditions, which provides a sturdier structure and wd which increases the load bearing capacity. The present embodiment

accomplishes these needs by incorporating a number of new features, among others, an improved chain connection member, an improved guide system, an improved support and connection system, and an improved take up mechanism. These systems function individually and in combination to form a more secure locking engagement with the adjacent section chains, and to form a more structurally sound and stable tower.

A retractable column comprising at least two section chains arranged in an adjacent manner, each section chain having a plurality of sections pivotally connected to each other, an at least one chain connection member extending in an outward direction from each section whereby the chain connection members have a surface, the surface of the chain connection members converging towards a point, and whereby the chain connection members couple to one another to link each section chain to the adjacent section chain in such a manner as to form a rigid column.

A retractable column that can be stored on a take up mechanism, the column further comprising, an at least one section chain, each section chain comprising a plurality of sections pivotally connected in a line, the section chains being attached in such a manner that they can be rolled up on the take mechanism in a compact fashion and wherein each section is layered upon previous sections, a first connection member operably attached to each section wherein the first connection member extends in a horizontal manner from the section, a second connection member operably attached to each section wherein the second connection member extends in an off-set manner from the section, wherein the

connection members are curved and wherein when the section chains are extended from the take up mechanism and into a corresponding position the section chains operably couple by attachment of the sequential attachment of first connection members to second connection members.

5 An apparatus for raising a retractable column, the apparatus comprising an at least one section chain, the section chains operably positioned so that they may be raised and lowered concurrently, the raising and lowering of each section chain acting to couple each section chain to the adjacent section chains to form a column, a guide tower, the guide tower situated so that as the section chains are
10 raised, the section chains move up the length of the guide tower and are guided into a position that facilitates the coupling of each section chain to the adjacent section chains to form a column, an at least one guide roller, the guide roller operably attached to the guide tower so that the guide roller operatively interacts with a portion of the sections of the section chains to guide the section chains into
15 position where each section chain may be physically coupled to the section chains adjacent to it, an at least one shim each shim operably attached to the guide tower, the shims providing an adjustable platform for guiding the sections of the section chains into a position whereby the coupling of the adjacent section chains will be accomplished, and further comprising a motor operably affixed to
20 the guide tower, the motor effectuating the raising and lowering of each section chain.

A retractable column for supporting an overhead structure, the column further comprising, an at least one section chain, each section chain comprising a

plurality of sections pivotally connected in a line, the section chains being attached in such a manner that they can be rolled up on a take mechanism in a compact fashion with each section layered upon prior sections, a first hook attached to each section of the section chains, the first hook extending in a horizontal manner from each section, a second hook attached to the opposite side of each section from the first hook and in an off-set manner whereby each on a section is adjacent to an offset hook on an adjacent section, whereby when the section chains are raised in a concurrent manner, the first hooks from adjacent sections form an interlocking engagement with the second hooks from adjacent sections, the interlocking engagement binding each section chain to the adjacent section chains.

A method for erecting a retractable tower, the method comprising, providing adjacent section chains, each chain further comprising a series of pivotally connected sections, coupling the adjacent sections of adjacent section chains by linking corresponding mating hooks from each section chain, lifting the coupled section chains in a vertical manner as the adjacent section chains are coupled thereby forming each section chain into the face of a tower.

BRIEF DESCRIPTION OF THE ACCOMPANYING FIGURES

Figure 1a is an elevational rear view of a portion of the section chain of the present invention.

Figure 1b is an elevational rear view of one of the sections of the section chain of the present invention.

Figures 2 is a front view of the a chain connection member.

Figure 3 is a rear view of the chain connection member of Figure 2.

Figure 4 is an end on view of the chain connection member of Figure 2.

Figure 5 is an isometric view of the chain connection member of Figure 2.

5 Figure 6 is an isometric view of the guide tower with guide column of the present invention.

Figure 7 is a rear view of a section of the section chain of the present invention.

Figure 8 is a rear view of a section of the section chain of the present invention.

10 Figure 9 is a front view of the blade of the present invention.

Figure 10 is an isometric cut-away view of a portion of a vertical strut of the present invention with the teeth of the gear rack.

Figure 11 is a cut away sectional view of the gear rack, section, and the chain connection member of the present embodiment.

15 Figure 12 is an isometric view of the saddle of the present invention.

Figure 13a is a rear view of the gear rack.

Figure 13b is an isometric view of one end of the gear rack.

Figure 13c is an end view of the gear rack.

20 Figure 14 is a view of the end of the gear rack attached to the vertical strut.

Figure 15 is an isometric view of a section of the present invention.

Figure 16 is a side cut away view of the vertical strut with the gear rack attached.

Figure 17 is a side view of one side of the guide column of the present invention.

Figure 18 is an isometric view of one corner of the guide column of the present invention.

5 Figure 19 is an over the top cut away view of the guide column of the present invention.

Figure 20 is a cut away view of the gear rack of the present invention.

Figure 21 is an isometric view of the gear rack of the present invention.

10 Figure 22 is a front view of the take up mechanism of the present invention with sections of a section chain stored on the same.

Figure 23 is a front view of section chain of the present invention with the rollers and the guide rod attached to one end.

Figure 24 is a side view of the guide tower of an alternative embodiment of the present invention.

15 Figure 25 is an elevational isometric view of the alternative embodiment of Figure 24.

Figure 26a is a cut away view of the section ring of an alternative embodiment.

20 Figure 26b is an over the top sectional view of the tongue of an alternative embodiment.

Figure 27a is an isometric view of the fixed in place embodiment of the present invention in the non-extended position.

Figure 27b is an isometric view of the fixed in place embodiment of the present invention in the extended position.

Figure 27c is an isometric view of the fixed in place embodiment of the present invention in the extended position.

5 Figure 28 is an isometric view of several towers of the present invention in the extended position with a light assembly interconnecting the top of each tower.

Figure 29 is a top view of an alternative embodiment tower.

DESCRIPTION OF THE EMBODIMENTS

10 Additional features of the apparatus of the present invention will become more fully apparent and understood with reference to the above-referenced drawings, this description, and the appended claims, including the described embodiments of the extendable support column, and the description of erecting the device.

15 The accompanying Figures and descriptive material depict and describe embodiments of the present invention, including features and components thereof. With regard to fastening, mounting, attaching or connecting the components of the present invention to form the device or apparatus as a whole, unless specifically described otherwise, the invention may incorporate or use
20 conventional fasteners such as screws, nut and bolt connectors, etc. Unless specifically otherwise disclosed or taught, materials for making components of the present invention are selected from appropriate materials such as metal, metallic alloys, fibers, fabrics, plastics and the like, natural or synthetic, and

appropriate manufacturing or production methods including casting, extruding, molding and machining may be used. Furthermore, the members and components of the present invention may be constructed of solid formed pieces or hollow pieces, depending on the weight placed upon the tower while in use
5 and the structural strength of the material used to make the tower.

Any references to front and back, right and left, top and bottom, and upper and lower are intended for convenience of description, not to limit the present invention or its components to any one positional or spatial orientation. As used herein, the terms "tower," "extendable tower," or "retractable tower" are
10 intended to mean and/or encompass structures and/or apparatuses raised or raisable above a surface for providing a support column. Furthermore, each repetitive unit of the extendable tower may be referred to as a "section" or "link." Each section or link may be of increasing length for reasons described further herein. The strip of sections placed together may be referred to as a section
15 chain.

As illustrated in Figures 1b and 7, the retractable column 20 of the present invention in the extended position will be herein described. Figure 1 shows a front view of a portion of one section chain 22. The section chain is comprised of a series of successive sections or links 24 connected in a pivotal relationship.
20 The pivotal relationship of the successive sections 24 allows the sections 24 to pivot about a central axis extending through the space between the sections 24, as represented by line 25-25 in Figure 1.

As illustrated in Figure 7, each section 24 further comprises vertical struts 26 and 28, a crossbar 30, a cross brace 32, a cross bar kicker 34, and a gear rack 36. The vertical struts 26 and 28 are disposed on each side of the section 24 and fixedly connected in a rectangular shape with the crossbar 30. The struts 26 and 28 may also be referred to by other names or constructed in other manners known to those reasonably skilled in the art. The cross brace 32 is fixedly secured across the interior of the section 24 to provide further structural support. The cross bar kicker 34 of the present embodiment is a triangular shaped protrusion integrally formed on the surface of the crossbar 30. Operably connected parallel to the vertical strut 28 on one side is the gear rack 36. The struts 26 and 28, crossbar 30, cross brace 32, and cross bar kicker 34 of the present embodiment are formed of extruded aluminum. The vertical struts 26 and 28 and the crossbar 30 are formed of substantially one piece or, in an alternative embodiment, bolted together. As illustrated in Figures 7, 10, 11, and 16, the gear rack 36 may be an integral portion of the vertical strut 28 on one side of the present embodiment. Furthermore, as illustrated in Figure 10, one vertical strut 28 is further comprised of an indent guide 38. The indent guide 38 is formed out of one side of the strut 28. The utility of the indent guide 38 and the gear track 36 is further described herein.

As illustrated in Figures 1, 7, 11, and 15, each section of the section chain further comprises a chain connection member in the form of a pair of hooks 40 and a pair of blades 44. The blades 44 are rigidly secured to downwardly extend from the lower portion of each of the vertical struts 26 and 28. The chain

connection members of the present embodiment are in the form of a question mark, with a straight shaft portion and a hook portion on the distal end of the shaft. Furthermore, as seen in Figures 2-5, the distal hook portion of the present embodiment resembles a C shape. In other embodiments the C may be shorter, longer, or altered into various other shapes that can accomplish the desired result. In the present invention description the chain connection member 40 will be referred to as a 'hook 40,' but this in no way limits the scope of the present invention chain connection member.

As is further illustrated in Figures 2-5, the distal hook end of the hooks 40 of the present embodiment are skewed at an angle to the angle at which the elongated shaft rests. The angle at which the distal hook portion is set preferably less than ninety degrees. Even more preferably, the angle of the hook portion is approximately 30 degrees.

The hooks 40 of the present embodiment are furthermore secured to outwardly extend from the top portion of the crossbar 30. The blades 44, as illustrated in Figure 9, comprise an oblong shape with a rounded end 48, the entire blade 44 having a series of holes 50, 52, 54, and 56 disposed thereon. The rounded end 48 of the blades 44 protrude downwardly from the bottom portion of each vertical strut 26 and 28. A variety of pins are placed through corresponding holes in the strut to secure the rectangular portion of the blades 44 to the vertical strut 26 and 28.

As illustrated in Figures 2-5, the hook 40 further comprises a straight cylindrical rod 60, a hook portion 62, a tip 64, and a shoulder 66. The rod 60

may form the base of the hook 40 and the tip 64 is operably positioned on the end of the hook portion 62 which extends from the rod 60. The shoulder 66 juts outwardly from the rod 60. The shoulder 66 should be affixed in a position relative to the hook portion 62 so that the hook portion is presented at a desired
5 angle.

The tip 64 of the present embodiment is illustrated in Figures 2-5 as a pointed tip. The tip 64, however, may in fact be only slightly narrower than the hook 40 and thereby increase the interlocking engagement with other hooks 40. As may be appreciated, the tip 64 does not have to come to a point. A tip 64 that
10 narrows toward the distal end, however, may be preferable because it facilitates the coupling of the hook 40 with hooks 40 from the adjacent sections.

The shoulder portion 66 of the hooks 40 help to insure that the hooks 40 do not twist when pressure is placed upon the hook 40, either when the tower 20 is being raised or after the tower 20 is in position. Excessive pressure on the
15 prior art hooks caused by twisting of the locking pins often caused the pins to shear. The present invention adds a shoulder 66 to the cylindrical rods 60 of the hooks 40 to prevent all of the pressure from being placed on the locking pins and shearing them, thus preventing the degradation of the tower 20 stability.

As illustrated in Figures 1, 12, and 16, the successive sections 24 of the
20 tower 20 section chain 22 are overlapped in a blade and saddle fashion (similar to a tongue and groove). The blade 44 of the higher section 24 is inserted into a saddle 70 of the lower section. After the blade 44 is inserted into the saddle 70, the cylindrical rod 60 portion of the hook 40 is then placed through holes

disposed on either side of the saddle 70, through the blade 44, and then securely fastened by pins, bolts, or by any other manner known to those in the art. Figure 16 illustrates the rod 60 positioned through the holes disposed on either side of the saddle 70 without the blade 44. The manner in which the blade 44 interacts with the rod 60 and the saddle 70 may be easily imagined by those skilled in the art. The pivotal connections of the blade 44 and the rod 60 on either side of the crossbar permits the upper section 24 to pivot versus the lower section 24 along an axis extending between the successive sections 24 in the section chain 22, represented by line 25-25 in Figure 1. The gear teeth 36 of successive sections 24 are also be formed in such a way that enables them to pivot in relationship to one another.

The interaction of the cylindrical rod 60 with the blade 44 of the next successive section 24 also allows the sections 24 of the section chain 22 to be secured in a way that the whole section chain 22 can be drawn up by a drive mechanism 72, but still allowing the sections 24 to be in a pivotal relationship with one another. Each side of the section 24 in the section chain 22 has one of the hooks 40 for engaging a similar hook 40 on an adjacent section 24. The saddle 70 and blade 44 arrangement may present a hook 40 on both sides of each successive section 24 of the section chain 22. The blade 44 and saddle 70 combination increases the reliability and structural integrity of the present invention tower 20.

As illustrated in Figures 1-5, 7, 8 and 15, and as noted above, each section of the section chain 22 may comprise two hooks 40. The hooks 40 form a

locking engagement with a corresponding hook 40 on an adjacent section chain 22 to form the tower 20. The hooks 40 are shaped and positioned so that they can be readily hooked together by concurrently raising the adjacent sections of the section chains 22, thereby raising the hooks 40 into connected cooperation with one another. Once the hooks 40 are in connected cooperation, the hooks 40 securely bind the section chains 22 to one another, forming the rigid tower 20 of the present invention. Similarly, to unhook or decouple the hooks 40, the adjacent sections of the section chains 22 may be concurrently lowered, thereby allowing the hooks 40 to decouple and return to their original position. The removable connection of the adjacent section chains 22 permit each of the sections 24 that form the retractable tower 20 to be rolled up and stored on a separate take up mechanisms 80. The take up mechanisms 80 are further described below.

With reference to Figures 1-5, the hooks 40 will be further herein described. The hooks 40 extend laterally outward from the side of the crossbar 30 of each section in the section chain 22 and are fixedly connected to the same. Each section 24 of the section chain 22 further comprises one hook 40 that extends perpendicularly and co-planar with the plane of section 24 and one that is substantially perpendicular to the plane of section 24. Those hooks that extend directly perpendicular will be referred to herein as hooks 40, those that are offset will be referred to herein as 'offset hooks 42.' Figure 1 illustrates both the hooks 40 and the offset hooks 42 extending outward from the section chain 22.

As illustrated in Figures 1 and 23, the hook 40 on one side of the section 24 of the section chain 22 has an offset hook 42 on the other side. In the next successive section 24 of the section chain 22, the sides on which the offset hooks 42 and the hooks 40 are present may be reversed. The next successive set of 5 offset hooks 42 and hooks 40 may be fixedly connected in a similar manner to the first section 24, so that an alternating pattern results. The adjacent sections 24 to either side should have an offset hook 42 or a hook 40 to mate with the corresponding hook 40 or offset hook 42. Other arrangements of hooks 40 and offset hooks 42 may easily be implemented as long as the hooks 40 and 42 10 interact with the corresponding type to form the proper engagement.

The offset hooks 42 have one end extending upward and through the opening of the corresponding hook 40. It is the interlocking engagement formed between hook 40 and hook 42 that provides the lateral connection to hold adjacent section chains 22 in a position next to each other. The adjacent struts 26 15 and 28 contact each other to prevent the inward collapsing of the section chains 22 while the offset hooks 42 and the other hooks 40 prevent the sections of the section chains 22 from collapsing outward. In this way, successive couplings may be achieved in a more efficient manner. When multiple hooks 40 are connected to successive vertical struts as shown, the present invention tower may 20 be formed.

The rotational engagement of corresponding hooks 40 will be described. The struts 26 and 28 on the lower section 24 rotate in response to being driven up by a drive mechanism 72. In doing so, the hook 40 may be rotated about its

central axis. The adjacent offset hook 42 is also be rotated about its central axis in the same manner. The use of the hooks 40 and the offset hooks 42 permit the operator to actuate the drive mechanism 72 and thereby rotate the hooks 40 until they are coupled into interlocking engagement as the struts 26 and 28 reach a
5 vertical position. The present invention permits the user to couple the sections 24 of the section chains 22 into interlocking engagement through pivotal rotation of the section chains 22 from the horizontal to the vertical position. As may be appreciated by those skilled in the art, as the corresponding sections 24 of the section chain 22 rotate in different directions during the retraction of the tower
10 20, the hooks 40 decouple from their interconnecting engagement.

In the present invention, the point 64 on the end of the hook portion 62 of the hooks 40 and 42 facilitate the consistent and secure coupling engagement of corresponding hooks 40, as the blunt end of the prior art hooks were easily bound against the corresponding hook without effectuating the proper locking
15 attachment. Although both hooks 40 have a pointed C shape 62 for engaging with one another, the offsetting of one of the hooks 42 in a hook pair permits one to couple or decouple the hooks from one another solely through the pivotal rotation of the end of each section in the section chain 22 as the link chain 22 is lowered.

20 As illustrated in Figures 13, 14, 16, and 20-21, the attachment of the gear rack 36 to the strut 28 will be herein described. As illustrated in Figures 20 and 21, the gear rack 36 of the present invention is attached to the strut 28 utilizing recessed fasteners 77. The recessed fasteners 77 are placed in an alternating

manner so that some of the fasteners 77 have the head exposed between the teeth of the gear rack 36, as illustrated in Figure 21, and so that minimal gear rack 36 cross-sectional area is lost. Other fasters 77 are illustrated in Figure 20 where the head of the fastener 77 is exposed from the rearward side of the gear rack 36, as
5 illustrated in figure 16. This locking mechanism can be In this manner the gear rack 26 is affixed to the strut 28 is a secure fashion.

The fasteners 77 above are not able to take the entire sheer weight of the tower 20 alone. The present embodiment, as illustrated in Figures 13a-c, and 16, illustrate a T slot 79 machined in to the back side of the gear rack 36. This T slot
10 79 fits over a T fastener machined onto the gear rack 36 as illustrated in Figure 16. (The T fastener is not shown). When the gear rack 26 is placed against the strut 28 the T slot 79 fits over the T fastener. This T faster and T slot 79 combination help to secure the gear rack 36 to the section 24 and the strut 28.

In addition to the T slot 79 and corresponding T fastener, illustrated in
15 Figure 16 are a number of keys 81. The keys 81 of the present embodiment are quarter inch stainless steel slugs which are driven horizontally into corresponding grooves 83. The keys 81 of the present embodiment are designed to take the majority of the sheer stress placed upon the gear rack 26 when raising and lowering each section 24. As may be appreciated, each gear rack 26 will have
20 thereon the weight of tower 20 while that gear rack 36 is in connection with the driver motor and being raised. The bolts 77, and the T slot 79 and T fastener connections, of the present embodiment are therefore not designed to take the

entire sheer force generated by this weight. In addition, the strength of gear rack 36 is not reduced by welding.

The improved attachment of the gear rack 36 to the vertical strut 28 represents an improvement in the present invention over the prior art. The improved connection of the gear rack 36 insures that the gear rack 36 will not come lose even under the most adverse circumstances. If the gear rack 36 were to twist in any manner, come lose, or possibly even come off, then the section 24 would not be properly engaged by the drive mechanism 72 and would disrupt the coupling of the adjacent section chains 22 whereby reducing the strength of the resultant tower.

As illustrated in Figure 22, the take up mechanism 80 of the present invention will be herein further described. The nesting relationship of the take up mechanism 80 with the successive sections 24 of the section chain 22 present an advantage of the present invention tower 20. Figure 11 shows a sectioned portion of the nesting relationship of a series of sections of a section chain 22. Each of the successive sections 24 of the section chain fit over the earlier sections 24 already taken up on the square shaped box core 86. The nesting relationship of the successive sections 24 in the section chain 22 allow the tower 20 of the present invention to be stored in a relatively small area.

As illustrated in Figure 22, the take up mechanism 80 comprise a square box shaped core 86 with four face members 90, 92, 94, and 96. Each face member 90, 92, 94, and 96 support and store the sections 24 of the section chain in a square shaped roll as the tower is retracted. As illustrated in Figure 23,

extending through the center of take up mechanism is a pivot rod 97 that is rotatably supported on one end by a first roller brace 98 and on the opposite end by a second roller brace 100. As illustrated in Figure 22, the first and second roller braces 98 and 100 roll along a first track 102 and a second track 104 which extends in an upwardly slanted manner in an outwards direction from the tower 20 base. As sequential sections of the section chain 22 are rolled around the square box shaped core 86, the rollers 98 and 100 allow the rack to move in an outwards direction to receive the next section 24. When a complete section 24 is folded onto the square box shaped core 86, the pivot point between the sequential sections allows the box shaped core 86 to travel, via the rollers 98 and 100, back down the slanted tracks 102 and 104, readying the system for the take up of the next sequential section 24 of the tower 20. The slope of the first track 102 and the second track 104 provide an inward force to the take up mechanism 80. The interaction of the linked drive mechanism and the roller braces 102 and 104 provide a constant and concurrent take-up of each side of the tower 20 as the tower 20 is retracted. An identical system may connect the roller base to the take up mechanism and the section chain located that form the other sides of the retractable column.

In order to compactly store the sections of the of the tower 20 on the take up mechanism, the section chain 22 sections 24 may be of increasing length. In other words, as illustrated in Figure 1a, the sections 24 at the top of the section chain 22 may have a length A and the successive section 24 may have a length B, the length B being slightly shorter than length A. Similarly, the next successive

section 24 may have a length C that may be slightly shorter than length B. The purpose of the different size sections 24 is to permit the individual sections 24 to be wound on to the square take up mechanism 80 in a layered fashion, as illustrated in Figure 22. As more sections 24 of the section chain 22 are wound
5 on to the take up mechanism 80, the diameter of the square shaped box 86 increases, requiring a longer section 24 to extend across the face of the take up mechanism 80 to complete the next layer of the box 86. This may be easily seen by looking at Figure 22. As will be appreciated by one skilled in art, other take up mechanisms 80 may not be box shaped, for example such mechanisms may
10 have five or six sides instead of four.

As illustrated in Figures 7 and 22, the operation of the kicker 34 will be herein further described. The kicker 34 of the present invention facilitates the correct stacking of the successive sections 24 in the section chain 22 when being rolled up in the take up mechanism 80. As can be seen in Figure 22, each section
15 24 becomes stacked on a section 24 that is actually four sections lower down in the tower 20. As the stack as a whole rolls back down the slope by action of the pivot rod 97 and the first and second roller braces 98 and 100, the whole stack will rotate counterclockwise (from the perspective of Figure 22). As the stack rolls and rotates in this manner, the topmost edge will rotationally move toward
20 the section 24 being sequentially stacked. The kicker 34 ensures that the queued section 24 is properly aligned with the section 24 underneath it in the take up mechanism 80. The kicker 34 insures that the new section 24 is not askew, either too high or low, or rotated at an angle, relative to the section 24 below it in the

stack. As may be appreciated, this is accomplished because if the new section 24 on the stack aligns in an incorrect manner, it will slip off kicker 34 and seat itself correctly.

As illustrated in Figures 6, 7, 18, and 19, the present invention further
5 comprises a guide column 110, an upper guide roller 112, a lower guide roller 114, an at least one shim 116, and a guide tower 118. The guide tower 118 resides in the middle of the three section chains 32 of the tower 20 as it forms. The guide tower 118 is on top of and houses the drive mechanism and drive teeth (not shown). The guide column 110 is fixedly attached to the guide tower 118 so
10 that it operatively rests along the inside of each of the section chains 22. The upper guide roller 112 and the lower guide roller 114 are fixedly connected to the guide tower 118 to operably interact with the opposite edge from the indent guide 38. The shims 116 are fixedly attached to the guide tower 118 in a position behind the vertical struts 26 and 28 to insure the proper vertical alignment of the
15 sections of each section chain. The accompanying figures generally show the rollers 112 and 114, shim 116, etc., that interact with one section chain 22 of the three that may be connected to form the tower 20 of the present embodiment. It is generally understood that each section chain 22 will have the corresponding structures described herein for guiding the section chain 22 as it is erected by the
20 drive mechanism 70.

As illustrated in Figures 1, 6, 17, 18, and 19, the above described guide tower 118 and the attachments thereto improve the stability and performance of the present invention tower 20. The upper and lower guide rollers 112 and 114

act to operatively engage the sections 24 as they are raised. The guide rollers 112 and 114 are adjustable to insure that each section 24 is guided into the correct position, thus insuring the correct locking engagement of the corresponding hooks 40 and 42. In the present embodiment, the guide rollers 112 and 114
5 engage a rolling surface 113 on the back of the gear rack as illustrated in Figure 16. The rolling surface 113 of the gear rack 26 are substantially smooth and of a shape that allows the rollers 112 and 114 to rotationally engage and guide the same.

In alternative embodiments, a person skilled in the art may add a greater
10 number of guide rollers to insure the correct positioning of the section chains 22 as they are raised and coupled to one another. As may be appreciated by one skilled in the art, having a multiple roller system may distribute the stress of guiding the sections 24 of the section chains 22 among more rollers, thereby improving the alignment of the sections 24. In the present embodiment, the
15 guide rollers 112 and 114 may utilize a ceramic impregnate fiber roller bushing, a brass washer, a hard coated aluminum roller, and a steel roller shaft.

As illustrated in Figure 17, the present embodiment further comprises interior rollers 115 and 117. Rollers 115 and 117 are operably attached to jut from below the shim 116 of the present embodiment guide tower. Figure 19
20 illustrates the lower guide roller 114 and an interior roller 117. The lower guide roller 114 rotationally engage rolling surface 113 of the gear rack 36 which is pointed internally toward the guide tower 118. The rolling surface 115 is on the opposite side of, and operably connected to, the gear rack 36 from the rolling

surface 113 previously described. The interior roller 117 may rotationally engage a rolling surface 119 the other side of the gear rack 36 as illustrated in Figure 10. Between the two guide rollers 112 and 115, the gear rack 36, and thus the entire section 24 is guided into a position that insures the accurate coupling of the hooks 40 and 42. The lower guide roller 114 operates in substantially the same way at a position below that of the upper guide roller 112 with the interior roller 117, guiding each successive section 24 into a position that facilitates the coupling engagement required to form the tower 20.

The interior guide rollers 115 and 117 may present another advantage to the present invention in that it provides another surface with which to guide the sections 24 of the section chains 22 into the proper position to couple the hooks 40 and 42. Furthermore, the interaction of the interior guide rollers 115 and 117 with the rolling surface 119 may distribute more of the stress of guiding the section chains 20 into position, further reducing the wear on the other guide rollers 112 and 114, the shims 116, and the guide tower as a whole 118.

As illustrated in Figures 10 and 19, the gear rack 36 of the present embodiment further comprises an indentation 37. The indentation 37 operably interacts with a protrusion 39 (illustrated in Figure 19). The protrusion 39 is operably positioned to extend from the shim 116 and in a vertically offset manner from the interior guide rollers 115 and 117 so that it does not bind in any way with the same. The protrusion 39 may interact with the indentation 36 as yet another guide for the gear rack 36. The indentation 37 and protrusion 39 keep the gear rack 36, and thus each section 24, in the desired position and path for

optimum coupling along with the guide rollers, shims, etc. The corresponding shape of the protrusion 39 and the indentation 37 may be designed in any manner that will accomplish the guiding of the gear rack 36. While the rollers 112, 114, 115, and 117 operably engage the gear rack 26 on a fairly continuous basis across the rolling surface 113 of the guide rack 36, the protrusion 39 does not continually rub against the indentation 37, but rather is a step that presents the gear rack 36 from straying too far from the desired point.

The shim 116 may operably engage one or both of the vertical struts 26 and 28 and the guide tower 118 in such a manner to align the sections 24 into the correct position, acting in coordination with the guide rollers 112 and 114. The guide column 110 may furthermore be a structure placed in a fixed relationship with the guide tower 118 in such a manner so that some of the above rollers 112 and 114 and shims 116 may be affixed thereon. The taller the guide tower 118, the greater the assurance that the sections 24, and hence the hooks 40 and 42, will be in alignment as the tower 20 is raised into position. The interaction of the take up mechanism 80, which provides a stable and reliable platform for storing the section chains 22, and the improved alignment of the sections chains 22 as they are raised, provides for a reliable and structurally sound retractable tower.

As illustrated in Figure 17, the drive mechanism 72 is located within the confines of the guide tower 118 with the drive gear 73 located in such a manner to cooperatively interact with the gear rack 36 of each successive section 24, thereby pulling/pushing the tower 22- into an upright position. The drive

mechanism 72 may comprise an electric motor that drives the gears; alternatively, other types of drive motors and arrangements may also be utilized.

In alternative embodiments, a drive reduction mechanism with a drive motor, such as an electric motor, allows the user to lift the sections of the section
5 chain upward even though there may be a load on top of the retractable column. The mating hooks 40 and 42, the various rollers 112 and 114, guides 110, etc., allow an 80 foot tower of the present invention, with a 5000 pound payload, to withstand winds in excess of 50 miles an hour. Further refinements in material and manufacture of the present embodiment may increase the height and payload
10 capacities of the present invention without changing the nature and scope thereof.

In still another embodiment, as illustrated in Figure 30, the tower 20 may be formed by raising the sections in the inside of the tower walls. In this embodiment, the rollers, shims, etc. would point inwards and engage the sections as they pass through the inside of the tower.

15 As illustrated in Figures 27-29, in another alternative embodiment, the guide tower 112 may further comprise three posts 130, 132, 134 and three reaction rings 136, 138, and 140. In this embodiment, the three posts 130, 132, 134 are rigidly assembled in a three corner design and affixed to a base. The guide tower 112 further comprise three tongues 142, 144, and 146 which extend
20 horizontally from each corner of the guide tower 112. The guide tower 112 is connected to the three posts 130, 132, and 134 by the three reaction rings 136, 138, and 140 and the three tongues 142, 144, and 146. The reaction rings 136, 138, and 140 allow the guide tower 112 to move in a horizontal plane in both the

X and Y directions. Movement of the guide tower 112 in the X and Y directions allows a slight movement of the tower 20 as the tower 20 is being raised. When raising the tower 20 in windy conditions, stress on the tower 20 may cause the tower 20 to bind against the guide tower 112 and therefore interfere with the coupling of the hooks 40 and 42. The operation of the reaction rings 136, 138, and 140 will now be described in terms of reaction ring 136.

The reaction ring 136 is further illustrated in Figure 26. As illustrated in Figure 26, the reaction ring 136 may further comprise a nut 148 and a washer 150. The tongue 142 is placed on top of the post 130 and the washer 150 is placed on top. As illustrated in Figure 26, the tongue 142 has a circular cutout area that is wider than the shaft of the nut 148. The nut 148 is placed through the washer 150, through the tongue 142, and then threaded and securely fastened into the top of the post 130. The nut 148 firmly presses the washer 150 on top of the tongue 142 and to the top of the post 130. The tension exerted by the nut 148, however, is selected so that when certain stresses are placed on the tower, the tongue 142 will slide a given distance over the top of the post 130, but still be secured from sliding off of the post 130 by action of the nut 148. As may be appreciated, various additions or alterations could be made to such an arrangement without changing the nature and scope of the present invention, for example, the addition of a spring or other shock system to soften the force of contact between the inside diameter of the tongue 142 and the side of the nut 148. As may be appreciated, the reaction ring may be constructed in a number of different manner. For example, the bolt and the post may be substantially formed

of one solid piece whereby the bolt has a narrow head that allows for the placement of the tongue over the top of the head, and after which a vertical stop is attached to the head of the bolt to prevent the tongue from slipping off of the top. In addition, other ways of implementing X, Y horizontal movement in this
5 manner may be imagined by those skilled in the art.

As a safety measure, in an alternative embodiment solenoid activated dogs may be provided that engage the corresponding gear racks on the back of the link braces. The solenoid activated dogs may stop the downward movement of the tower should the power supply be cut. Dogs of this nature are well known
10 to those reasonably skilled in the art. The top end of the dog may contain teeth that are normally spaced apart from gear rack teeth. If power should be cut off to the system, a solenoid release dog may rotate clockwise and into interlocking engagement with the teeth, thereby stopping the downward motion of the retractable column. Similarly, a pivotal dog is located in a normally spaced
15 relationship to the gear rack teeth.

As illustrated in Figures 27-29, many set ups of the present invention may be utilized in different manners. Some of these set ups may incorporate a mobile platform, much like an ordinary trailer, to carry the tower 20 apparatus to a site where it is raised. The size of the trailer and the weight of such a mobile set up may depend on the height and structural load capability of the tower.
20 Furthermore, fixed in place retractable towers may also be constructed. These fixed in place embodiments may be ideal where a tower is considered unsightly when not in use. The retractable tower may be covered over, with doors that

open when the tower needs to be extended. Those reasonably skilled in the art may imagine a variety of ways to implement the present invention.

As illustrated in Figure 29, in another alternative embodiment the tower 20 may be moved upwards and guided through the interior of the guide tower

5 112. As may be seen in this illustration, the rollers may point to the interior and guide the tower as it is raised through the same. As may be appreciated, further design changes may be made in this manner without changing the nature and scope of the present invention.

The information and examples described herein are for illustrative
10 purposes and are not meant to exclude any derivations or alternative methods that are within the conceptual context of the invention. It is contemplated that various deviations can be made to this embodiment without deviating from the scope of the present invention. Accordingly, it is intended that the scope of the present
15 invention be dictated by the appended claims rather than by the foregoing description of this embodiment.

CLAIMS

1. A retractable column comprising:
at least two section chains arranged in an adjacent manner, each section chain having a plurality of sections pivotally connected to each other; and
5 an at least one chain connection member extending in an outward direction from each section wherein the chain connection members further comprise a surface which slopes toward a point and whereby the chain connection members couple to one another to link each section chain to the adjacent section chain in such a manner as to form a rigid column as the section
10 chains are raised in an operably position.
2. The apparatus of claim 1 wherein the chain connection member further comprises an elongated shaft and a distal hook portion wherein the surface of the chain connection member that converges towards a point is represented by the distal hook portion.
- 15 3. The apparatus of claim 2 wherein each section comprises a first chain connection member extending in a substantially outward direction from the section and a second chain connection member extending in a substantially outward direction from the section and wherein a plane running through the hook of the second chain connection member is set at an angle to the elongated shaft.
- 20 4. The apparatus of claim 3 wherein the elongated shaft of the chain connection member has a shoulder portion wherein the shoulder portion prevents twisting of the shaft in relation to its connection to the section.
5. The apparatus of claim 1 further comprising:

a guide tower operably positioned relative to the two section chains wherein the guide tower engages the sections and helps to guide the first and second hooks into coupled engagement; and

an at least one guide roller operably connected to the guide tower and
5 operably interacting with the section chains whereby the guide rollers engage the sections and helps to guide the first and second hooks into coupled engagement.

6. The apparatus of claim 2 further comprising an at least one shim, the shims operably affixed to the guide tower whereby the shims engage the sections and helps to guide the first and second hooks into coupled engagement.

10 7. The apparatus of claim 5 further comprising an at least one interior roller, the interior rollers operably affixed to the guide tower whereby the interior rollers engage the sections and helps to guide the first and second hooks into coupled engagement.

8. The apparatus of claim 7 further comprising a gear rack fixedly connected
15 to each section of the section chain, the gear rack affixed by an extruded T-slot to which fasteners are attached through the gear rack and into the section whereby the gear rack is positioned to engage a drive mechanism and an at least one guide roller.

9. The apparatus of claim 8 wherein an at least one key is inserted into an at
20 least one slot thereby affixing the gear rack to the section of the section chain.

10. The apparatus of claim 9 wherein the drive mechanism is operably attached to guide tower and operably interacts with the section chains whereby

actuation of the drive mechanism raises the section chains into position so that the first and second hooks engage to form the column.

11. The apparatus of claim 1 wherein the guide tower further comprises an at least one tongue, the tongues movably connected to an at least one post by an at least one reaction ring whereby the guide tower can move in an X, Y horizontal plane.

12. A retractable column that can be stored on a take up mechanism, the column further comprising:

an at least one section chain, each section chain comprising a plurality of sections pivotally connected in a line, the section chains being attached in such a manner that they can be rolled up on the take mechanism in a compact fashion and wherein each section is layered upon previous sections;

a first connection member operably attached to each section wherein the first connection member extends in a horizontal manner from the section; and

a second connection member operably attached to each section wherein the second connection member extends in an off-set manner from the section, wherein the connection members are curved and wherein when the section chains are extended from the take up mechanism and into a corresponding position the section chains operably couple by attachment of the sequential attachment of first connection members to second connection members.

13. The apparatus of claim 12 further comprising a kicker, the kicker operably attached to the crossbar of each section of the section chain whereby when the section is taken up by the take up mechanism, the kicker shunts the

section into a properly seated position relative to the section underneath it on the take up mechanism.

14. The apparatus of claim 13 further comprising a drive mechanism operably attached to the section chains whereby actuation of the drive mechanism raises
5 the section chains into position whereby the interlocking engagement of the first and second connection members to form the column.

15. The apparatus of claim 14 further comprising:
a guide tower operably positioned to the two section chains wherein the guide tower engage the sections and helps to guide the first and second
10 connection members into coupled engagement; and
an at least one guide roller operably connected to the guide tower and operably interacting with the section chains whereby the guide rollers engage the sections and helps to guide the first and second connection members into coupled engagement.

15 16. The apparatus of claim 15 further comprising an at least one shim, the shims operably attached to the guide tower whereby the shims engage the sections and helps to guide the first and second connection members into coupled engagement.

17. The apparatus of claim 16 further comprising an at least one interior
20 roller, the interior rollers operably positioned on the guide tower whereby the interior rollers engage the sections and helps to guide the first and second connection members into coupled engagement.

18. The apparatus of claim 15 further comprising:

a gear rack fixedly connected to each section of the section chain, the gear rack affixed an extruded T-slot to which fasteners are attached through the gear rack and into the section whereby the gear rack is positioned to engage a drive mechanism and an at least one guide roller; and

5 an at least one key inserted into the gear rack and the section of the section chain whereby the gear rack is affixedly connected to the section of the section chain.

19. The apparatus of claim 15 further comprising a drive mechanism operably attached to the section chains whereby actuation of the drive mechanism raises
10 the section chains into position whereby the interlocking engagement of the first and second connection members to form the column.

20. The apparatus of claim 19 wherein the guide tower further comprises an at least one tongue, the tongues movably connected to an at least one post by an at least one reaction ring whereby the guide tower can move in an X, Y
15 horizontal plane.

21. An apparatus for raising a retractable column, the apparatus comprising:
 an at least one section chain, the section chains operably positioned so that they may be raised and lowered concurrently, the raising and lowering of each section chain acting to couple each section chain to the adjacent section
20 chains to form a column;

 a guide tower, the guide tower situated so that as the section chains are raised, the section chains move up the length of the guide tower and are guided

into a position that facilitates the coupling of each section chain to the adjacent section chains to form a column;

an at least one guide roller, the guide roller operably attached to the guide tower so that the guide roller operatively interacts with a portion of the sections
5 of the section chains to guide the section chains into position where each section chain may be physically coupled to the section chains adjacent to it;

an at least one shim each shim operably attached to the guide tower, the shims providing an adjustable platform for guiding the sections of the section chains into a position whereby the coupling of the adjacent section chains will be
10 accomplished; and,

and further comprising a motor operably affixed to the guide tower, the motor effectuating the raising and lowering of each section chain.

22. A retractable column for supporting an overhead structure, the column further comprising:

15 an at least one section chain, each section chain comprising a plurality of sections pivotally connected in a line, the section chains being attached in such a manner that they can be rolled up on a take mechanism in a compact fashion with each section layered upon prior sections

a first hook attached to each section of the section chains, the first hook
20 extending in a horizontal manner from each section; and,

a second hook attached to the opposite side of each section from the first hook and in an off-set manner whereby each on a section is adjacent to an offset hook on an adjacent section, whereby when the section chains are raised in a

concurrent manner, the first hooks from adjacent sections form an interlocking engagement with the second hooks from adjacent sections, the interlocking engagement binding each section chain to the adjacent section chains.

23. The retractable column of claim 22 further comprising:

5 a guide tower operably positioned relative to each section chain whereby the guide tower helps to guide the first and second hooks into operably engagement;

an at least one roller, the rollers operably attached to a guide tower, the rollers rotationally engaging the sections of the section chain as the section chain
10 is raised in a manner to form the tower, the rollers guiding the section chains into a position whereby the sections chains may be coupled to the adjacent section chains to form the retractable tower;

a motor in operably connection with each section chain and operably affixed to the guide tower, the motor effectuating the raising and lowering of
15 each section chain; and

an at least one reaction ring operably attached to the guide tower and connected to an at least one post whereby the guide tower can move in an X, Y horizontal direction.

24. A method for erecting a retractable tower, the method comprising:

20 providing adjacent section chains, each chain further comprising a series of pivotally connected sections;

coupling the adjacent sections of adjacent section chains by linking corresponding mating hooks from each section chain; and,

lifting the coupled section chains in a vertical manner as the adjacent section chains are coupled thereby forming each section chain into the face of a tower.

5

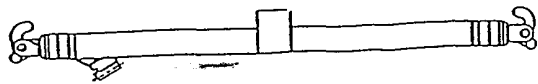

Figure 1b

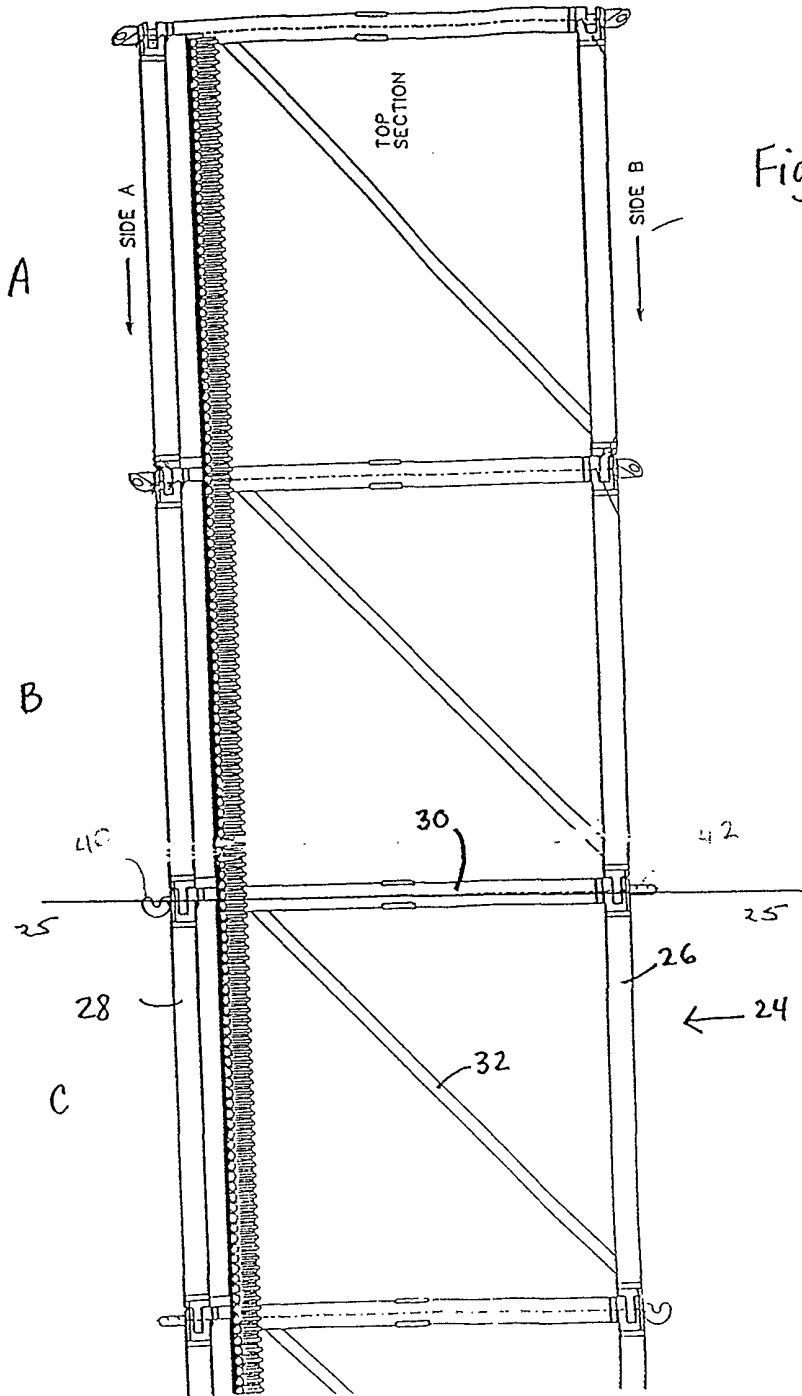

Figure 1a

22

Figure 2



Figure 3

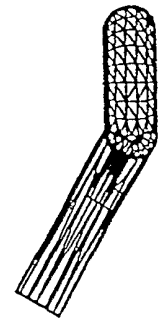

Figure 4

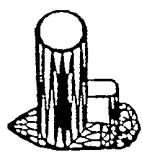

Figure 5

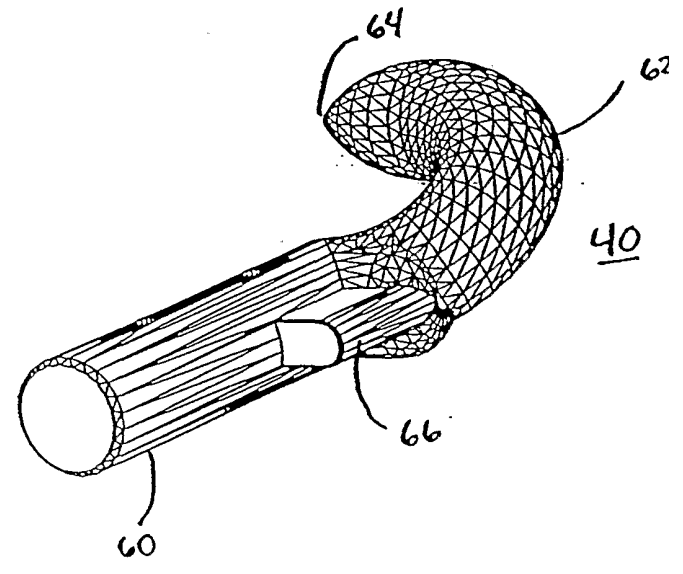

Figure 6

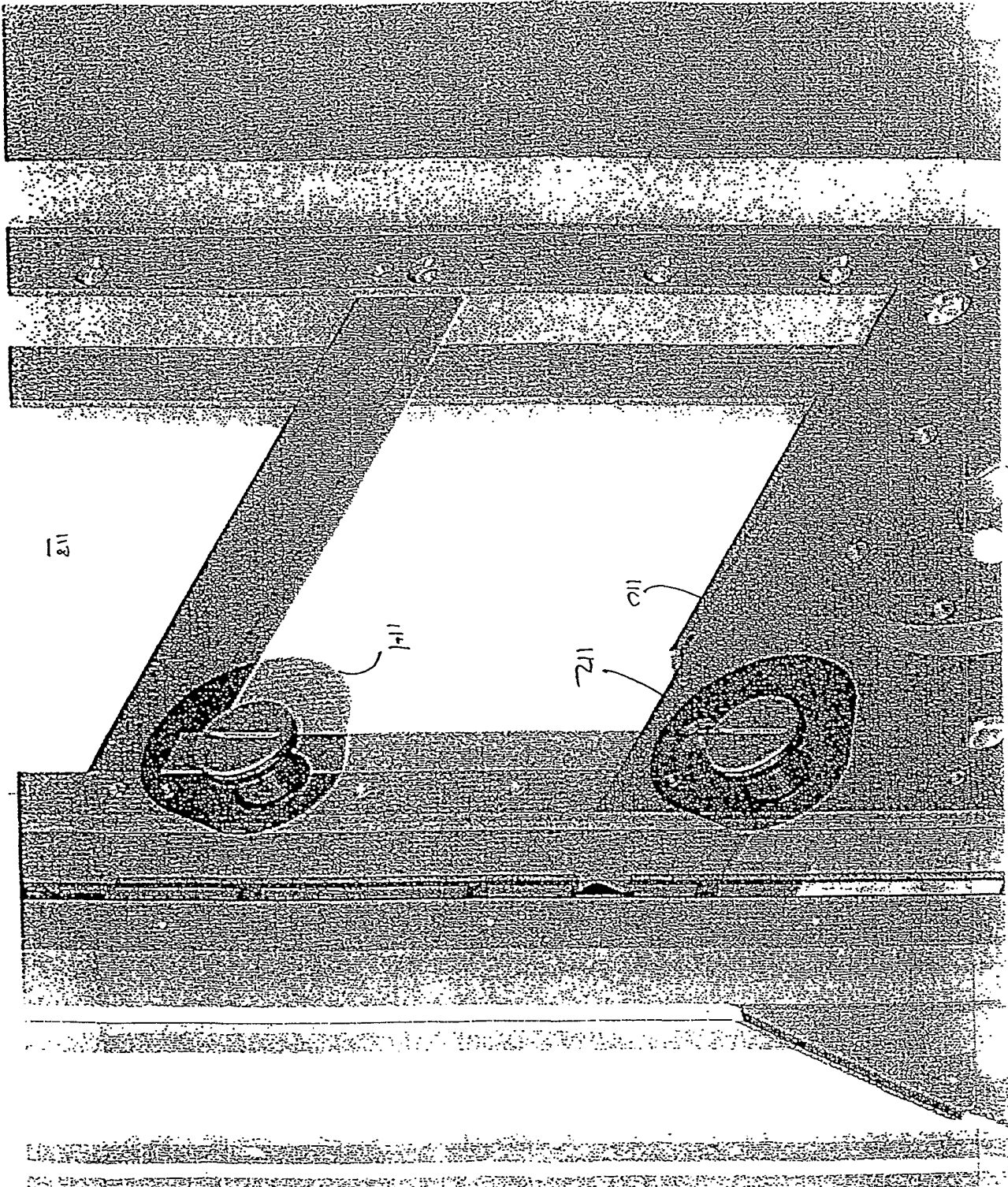
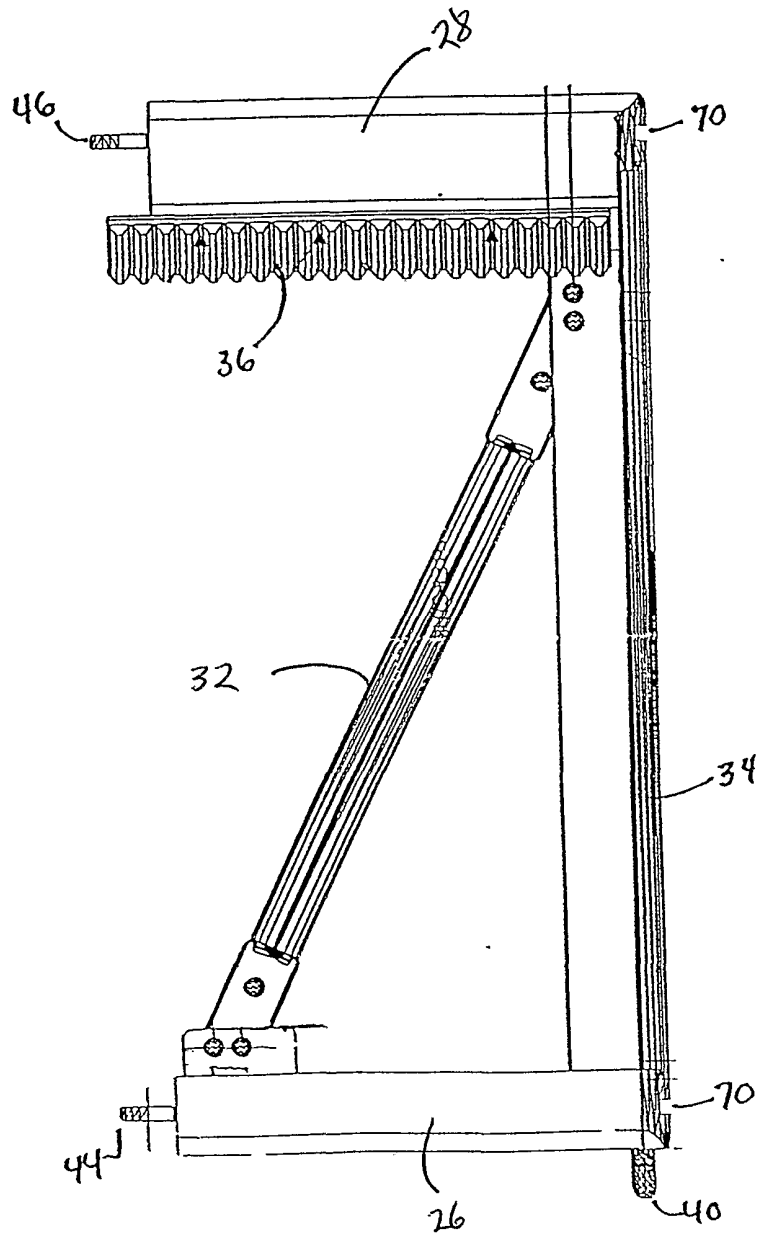

Figure 7



24

Figure 8

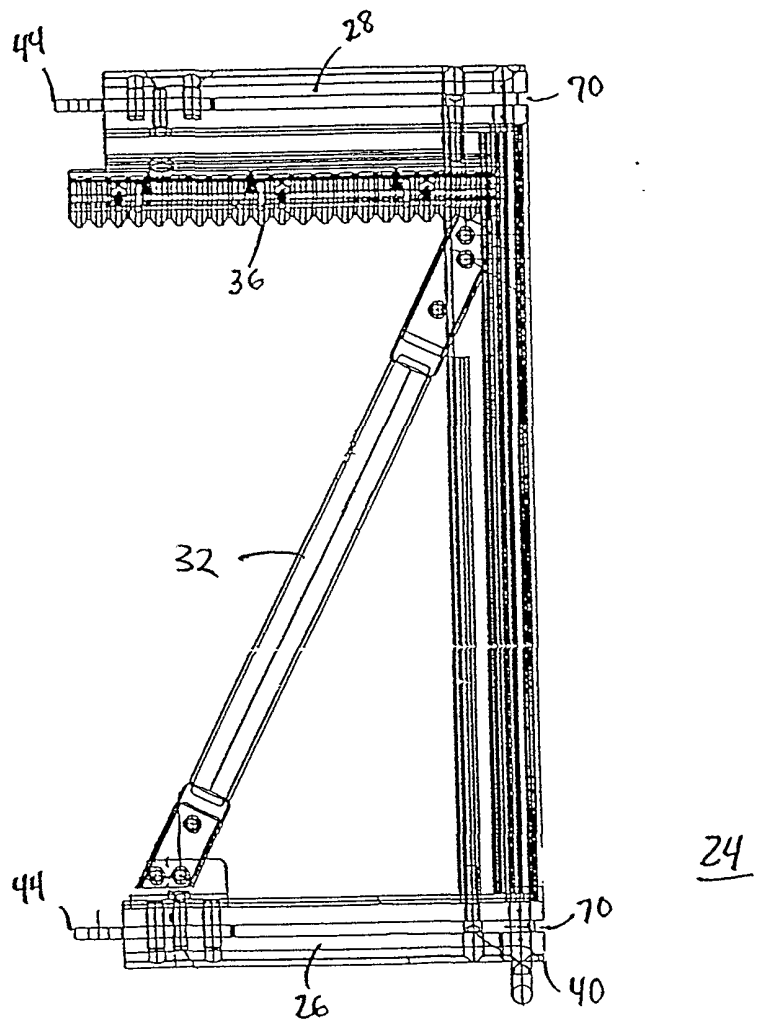

Figure 9

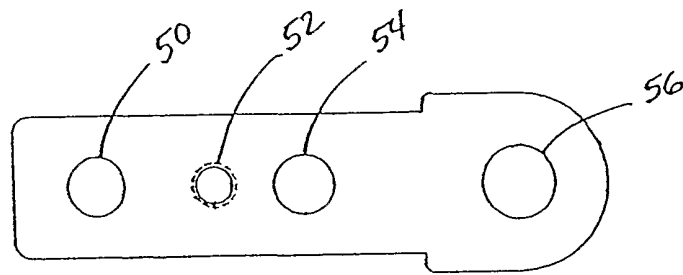
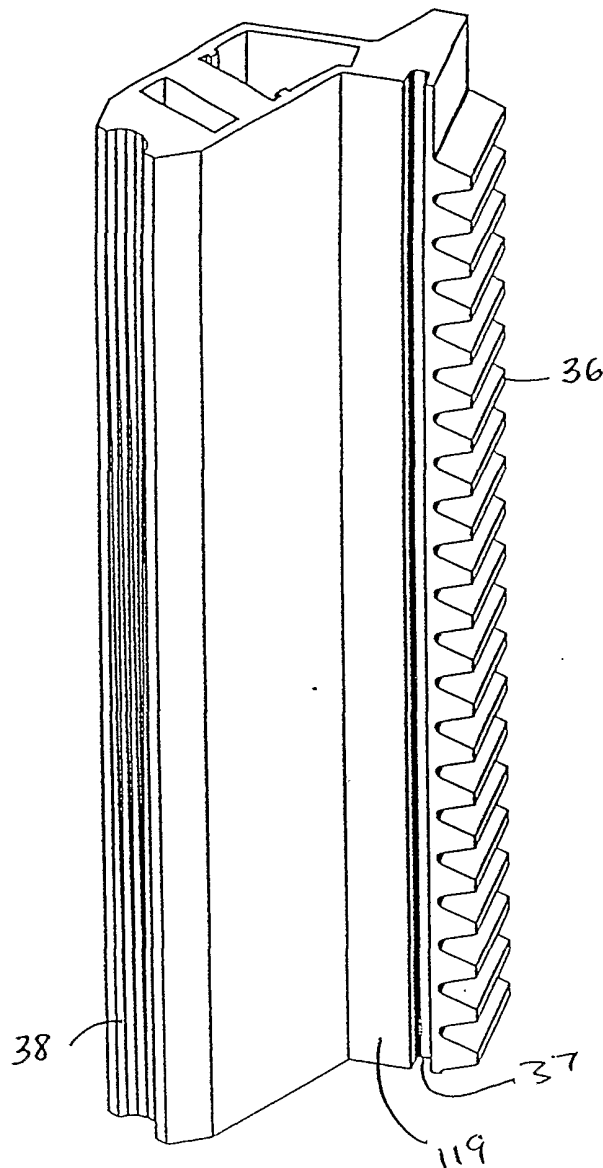

Figure 10



28

Figure 11

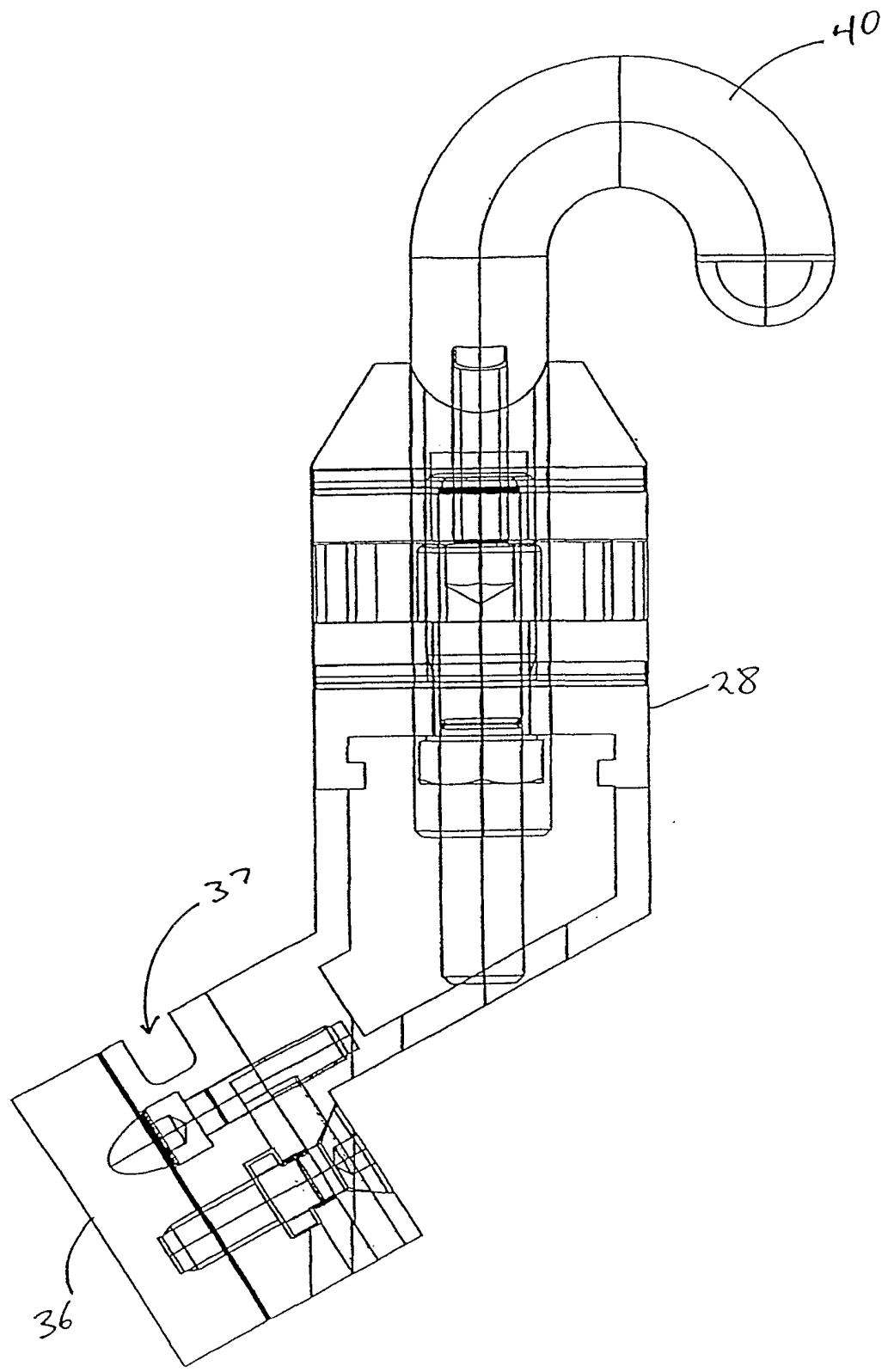

Figure 12

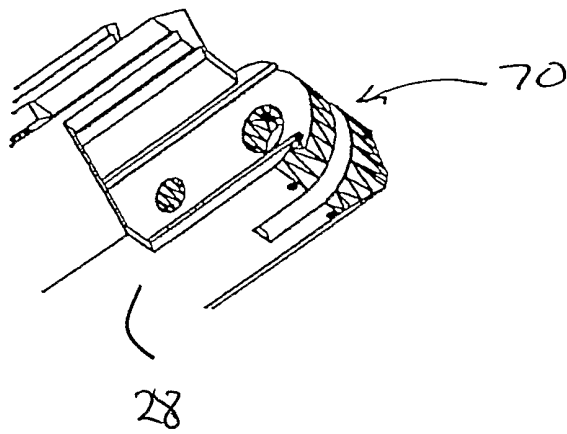

Figure 13a

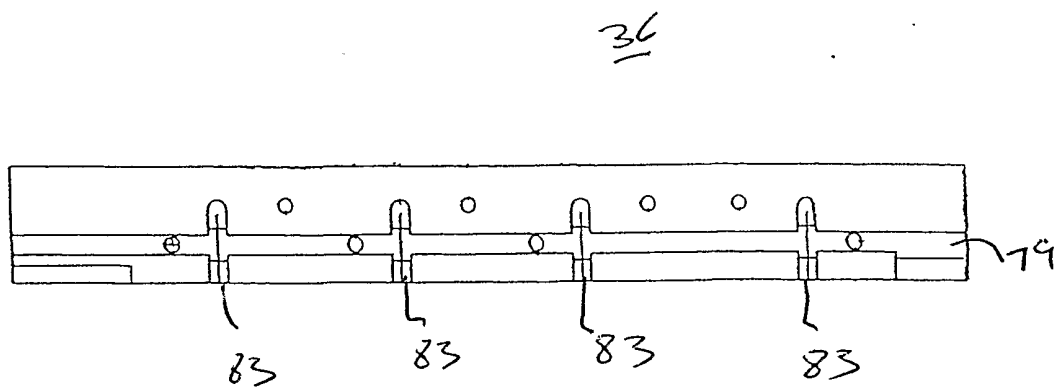

Figure 13b

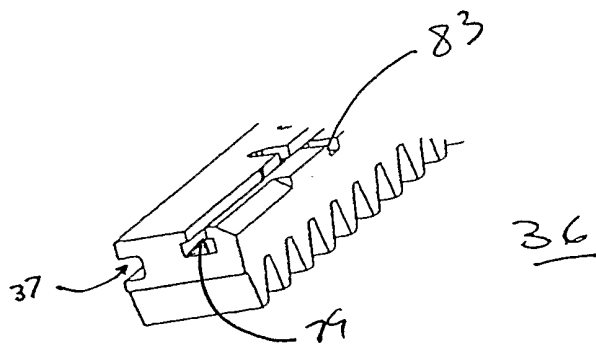
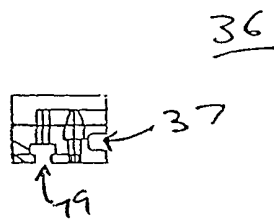

Figure 13c



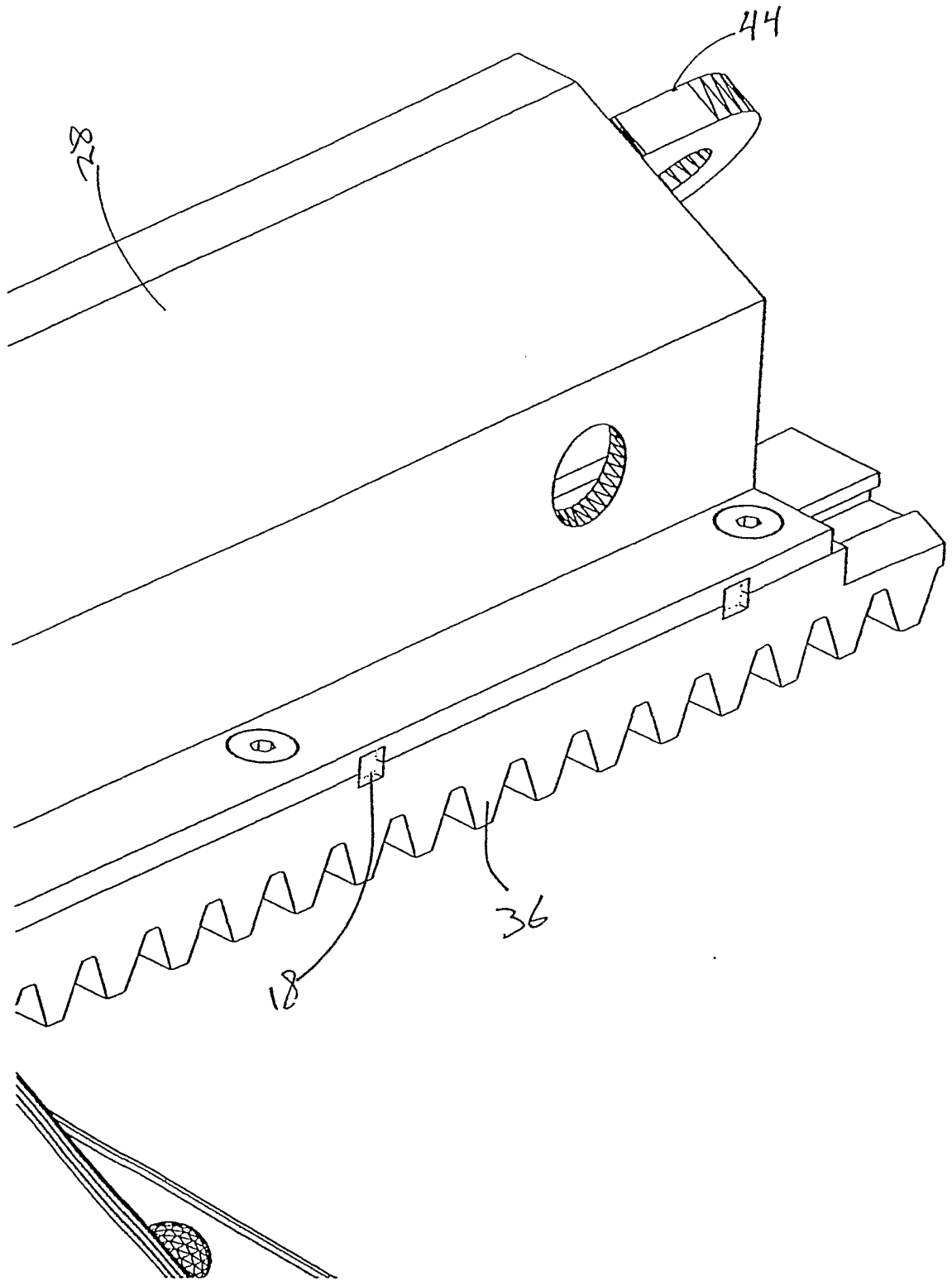

Figure 14

Figure 15

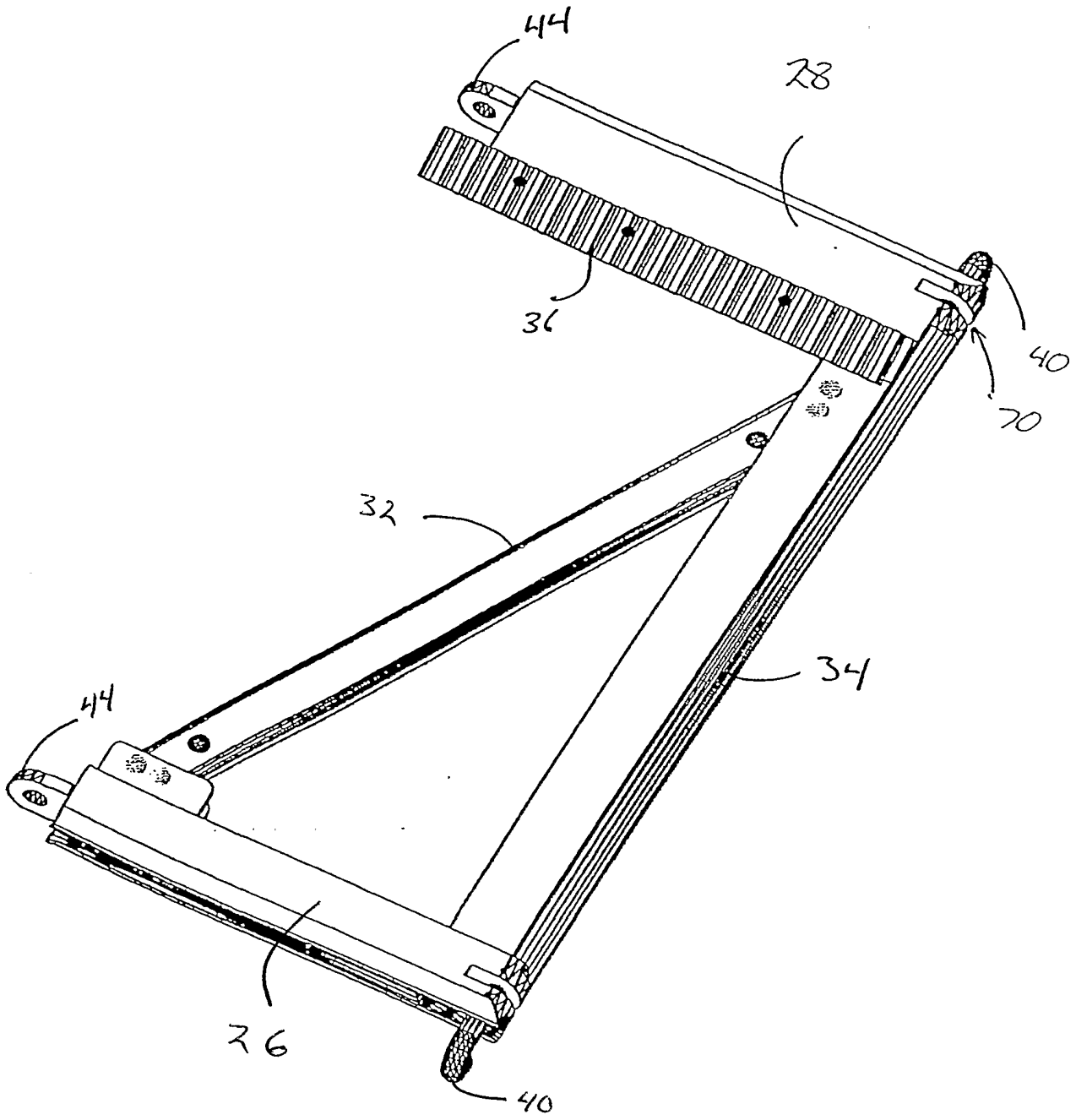

Figure 16

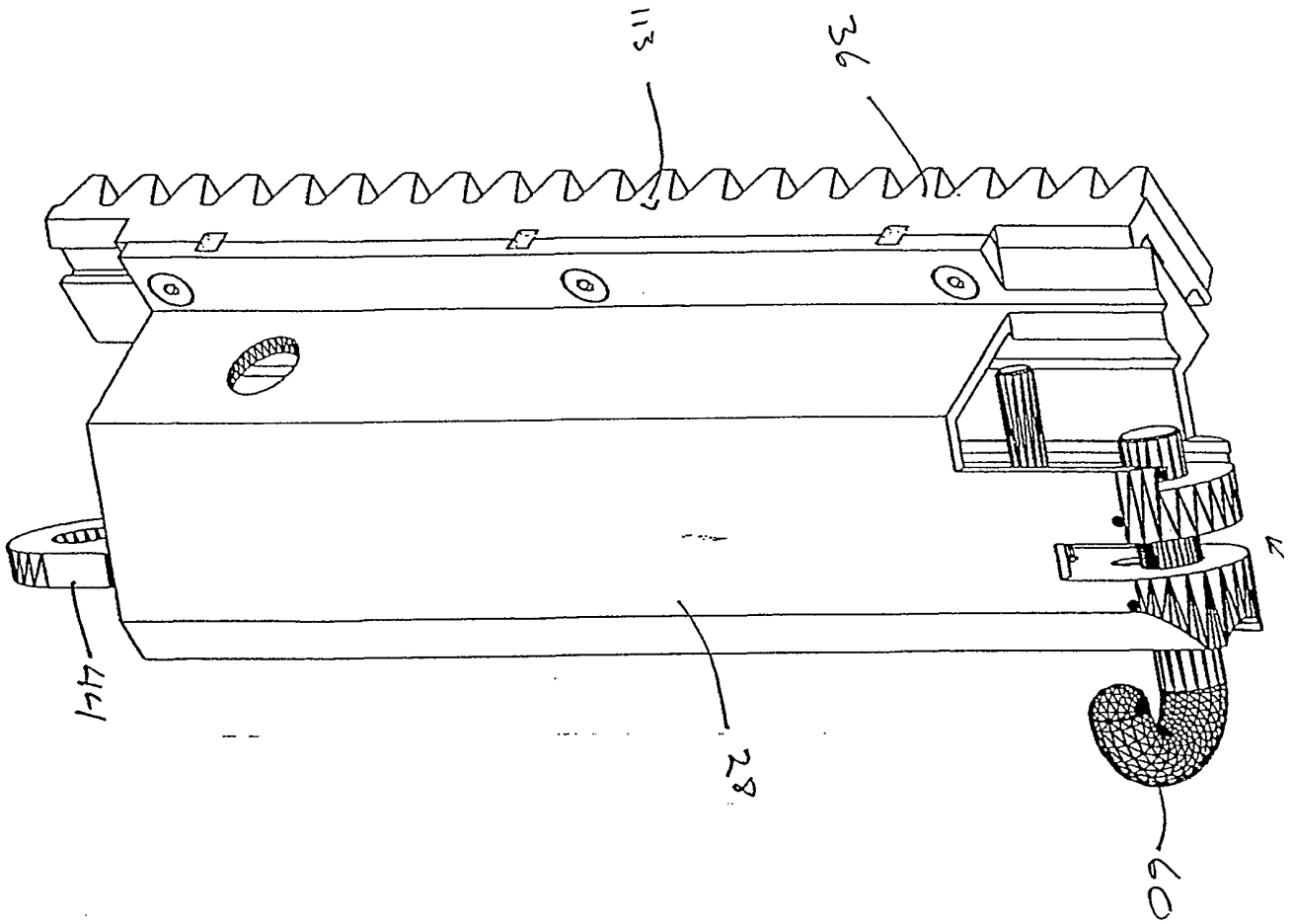

Figure 17

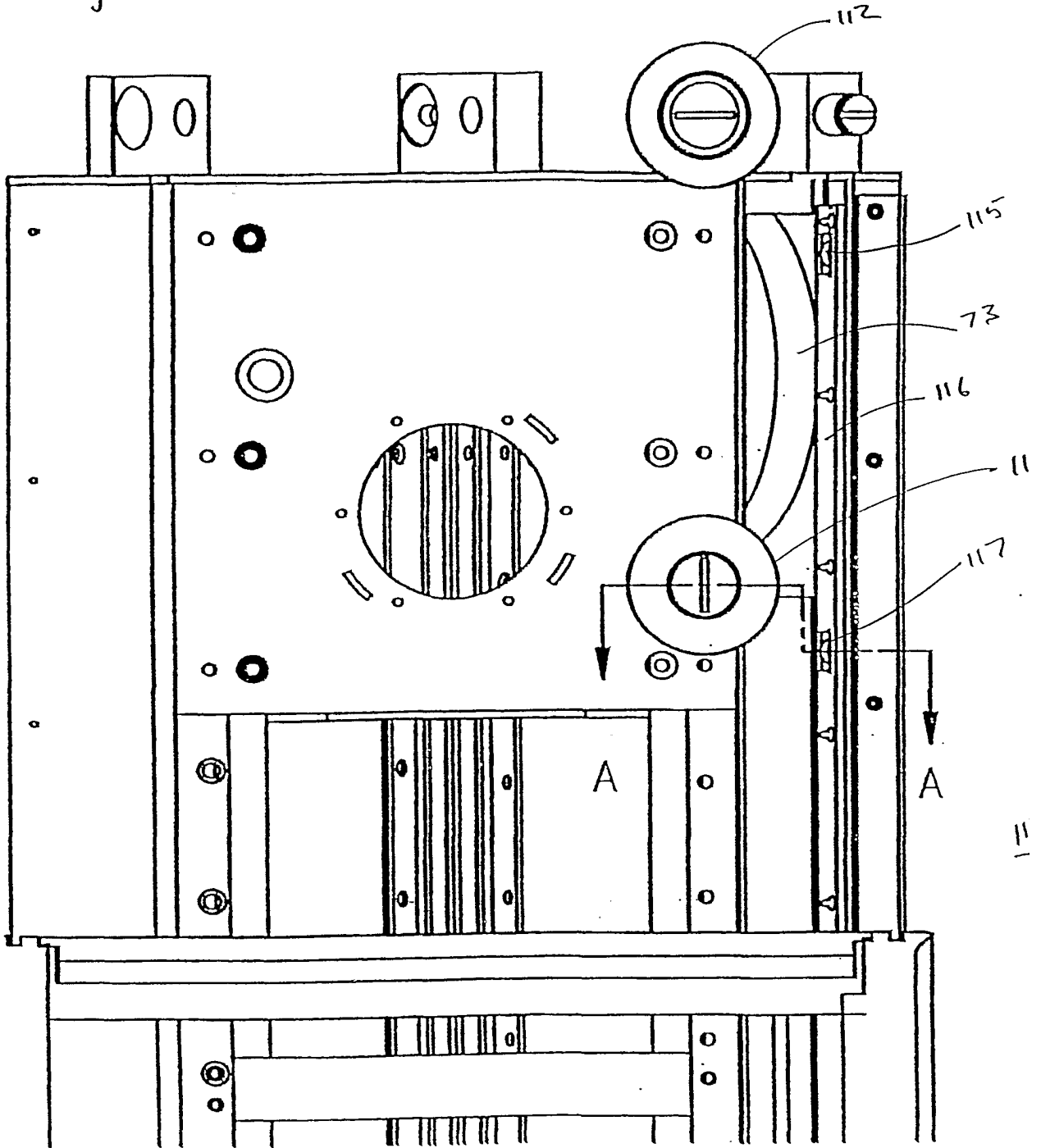

Figure 19

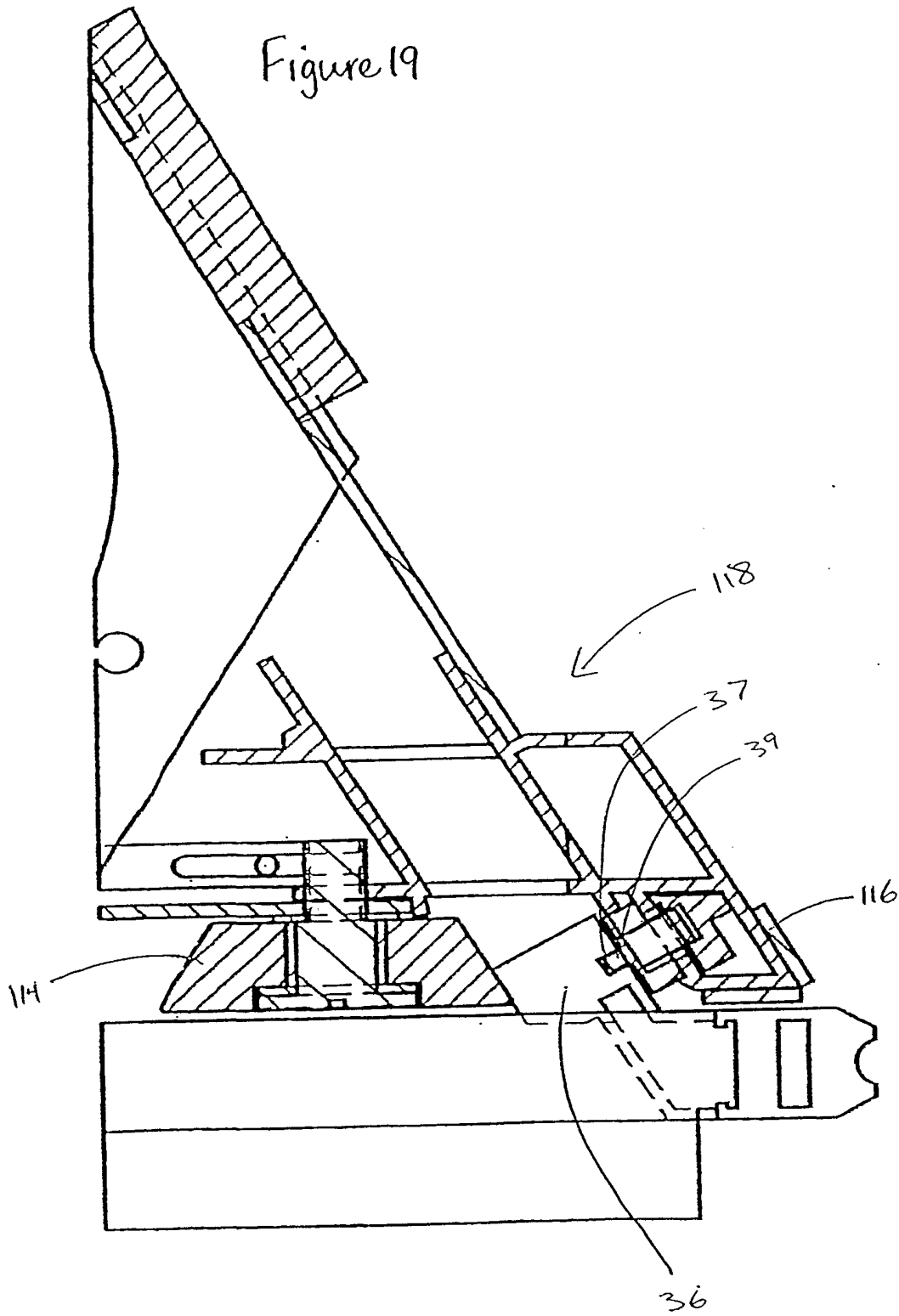

Figure 20

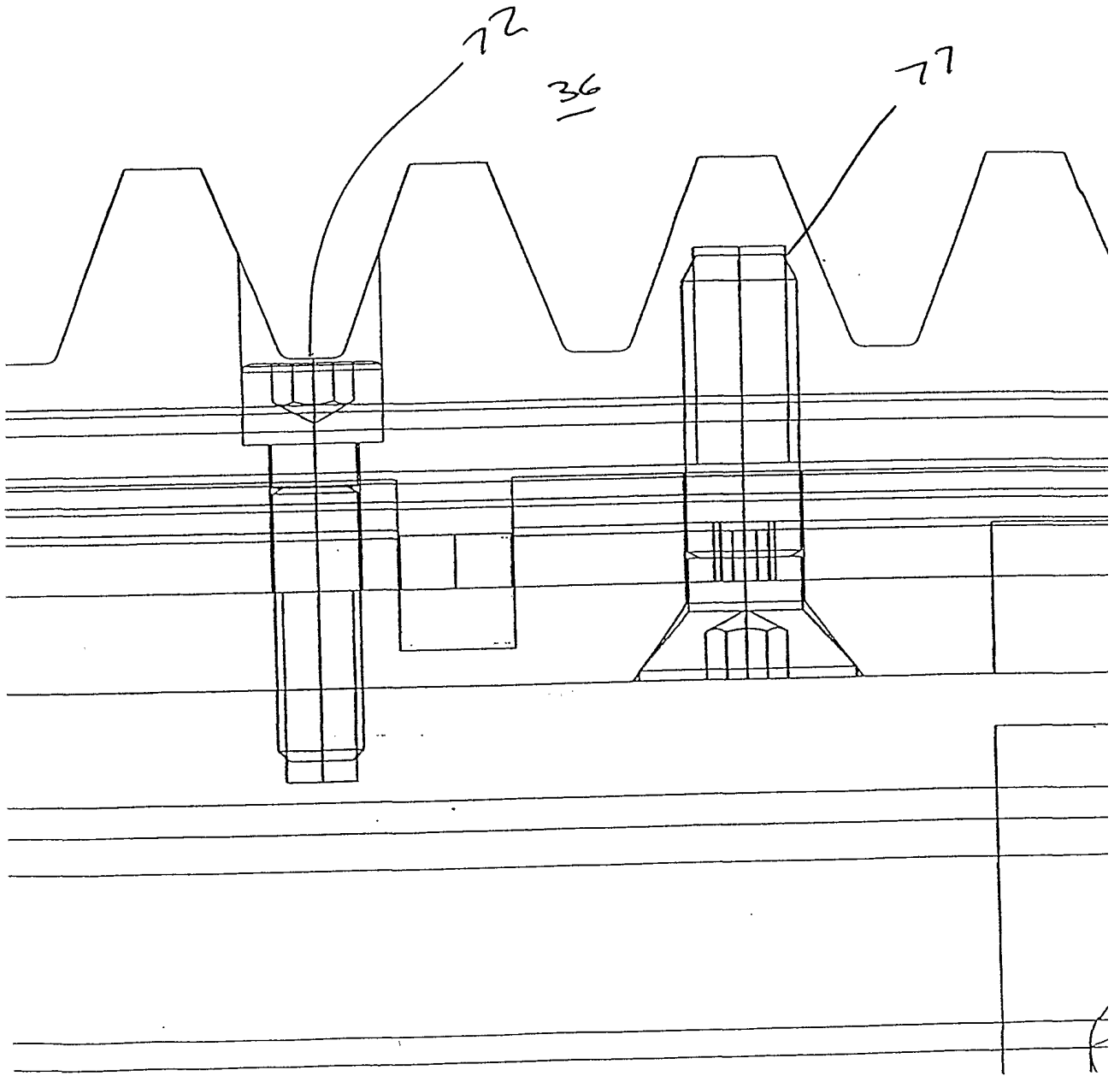

Figure 21

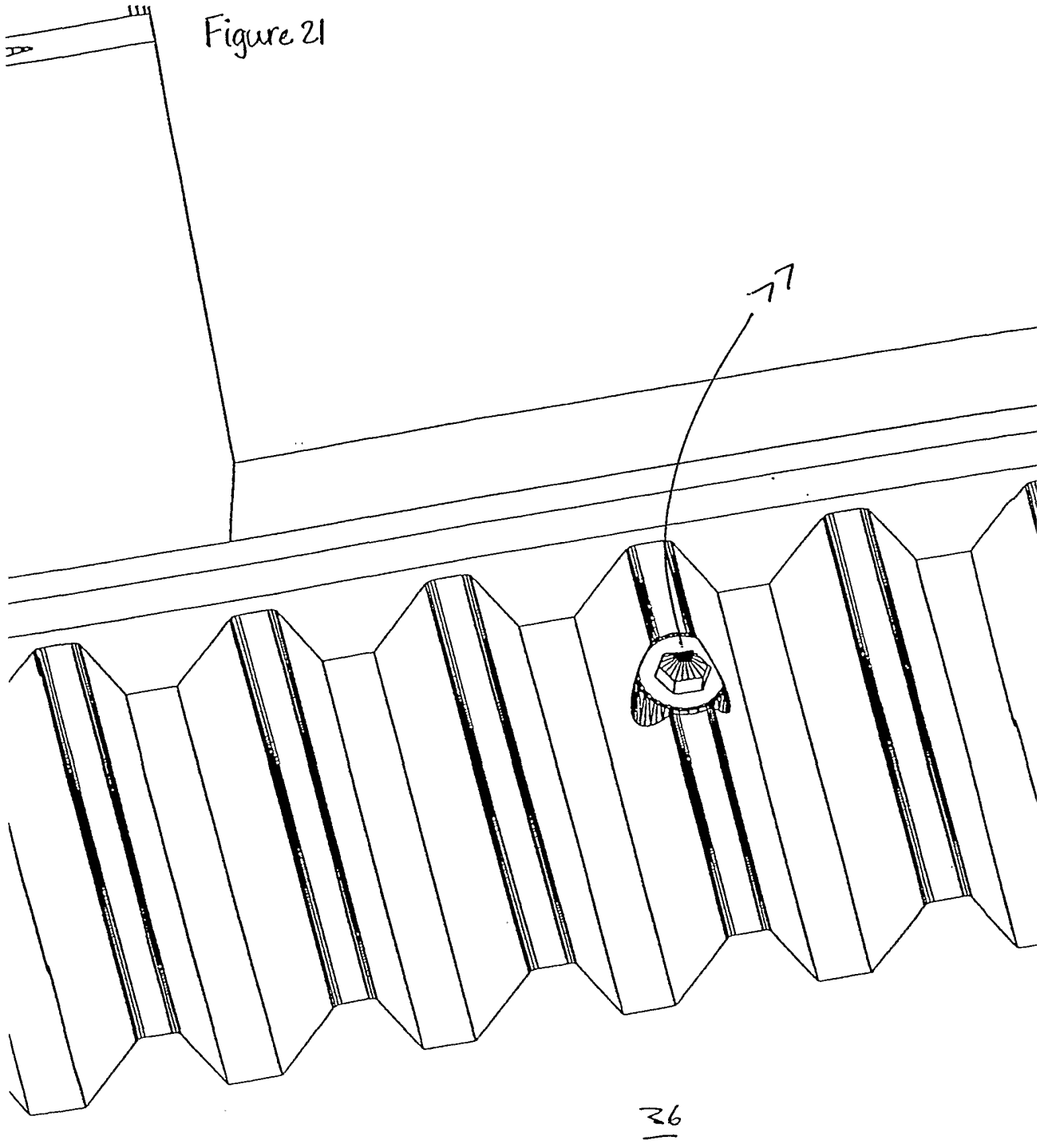

Figure 22

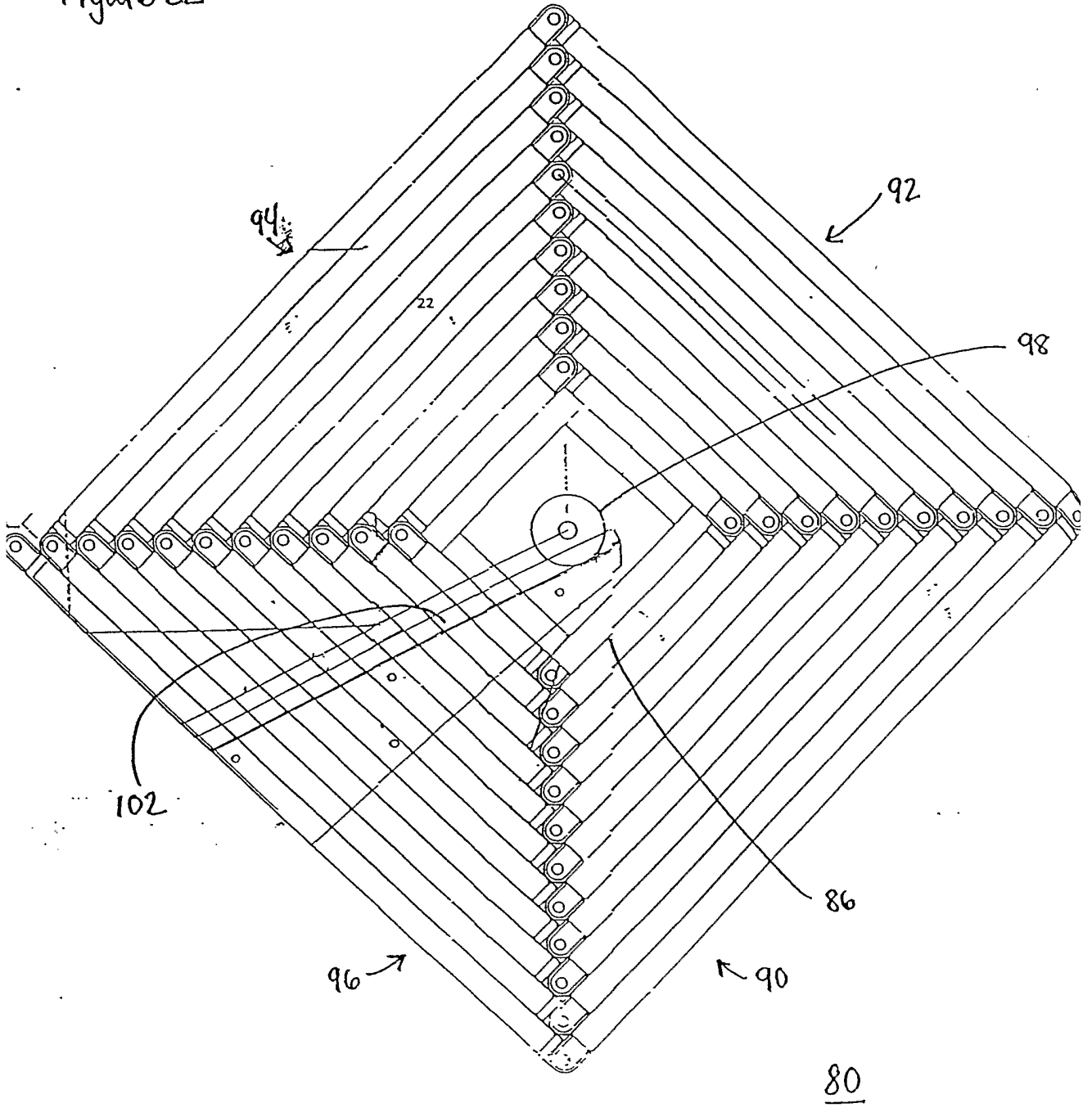

Figure 23

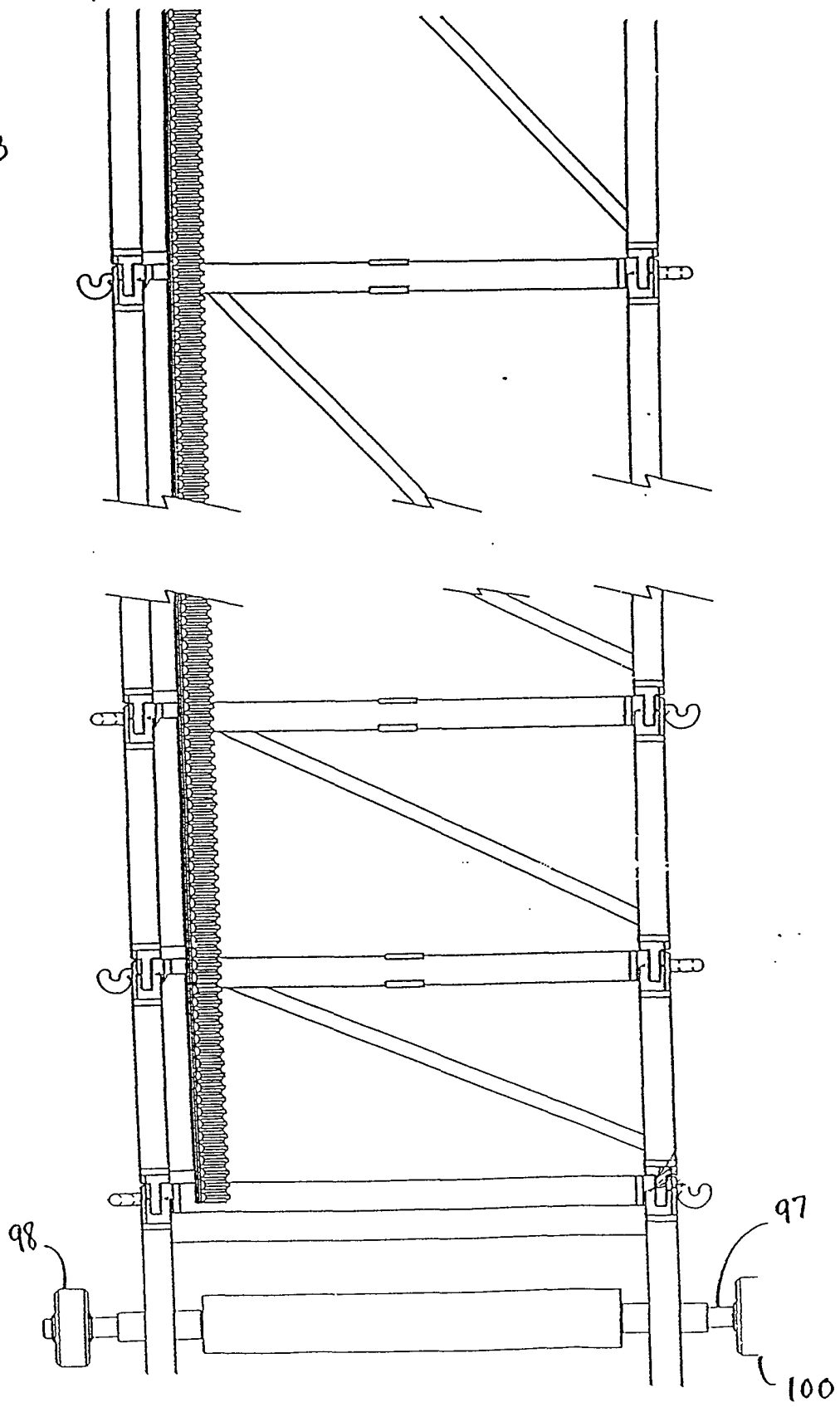
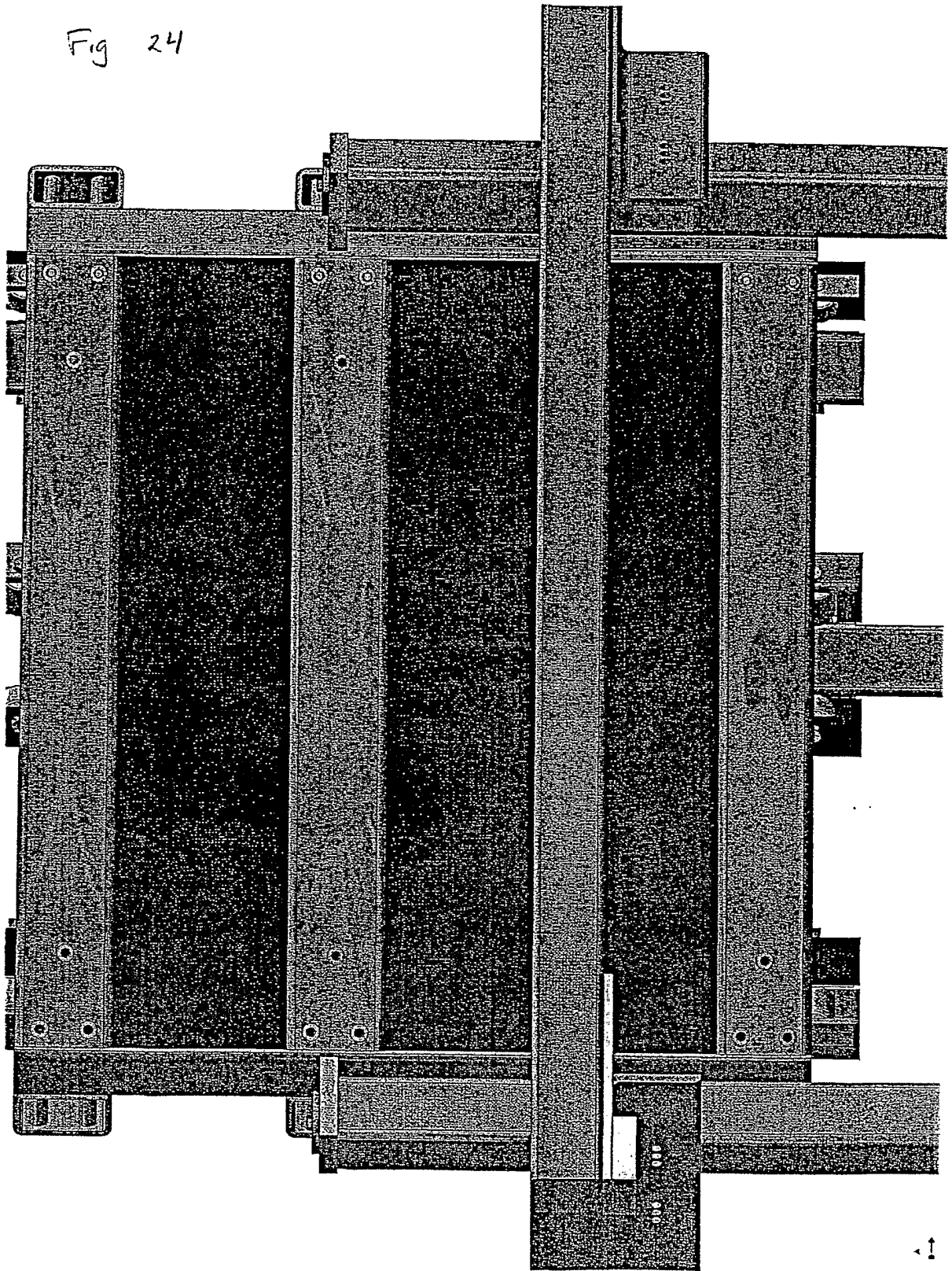

Fig 24



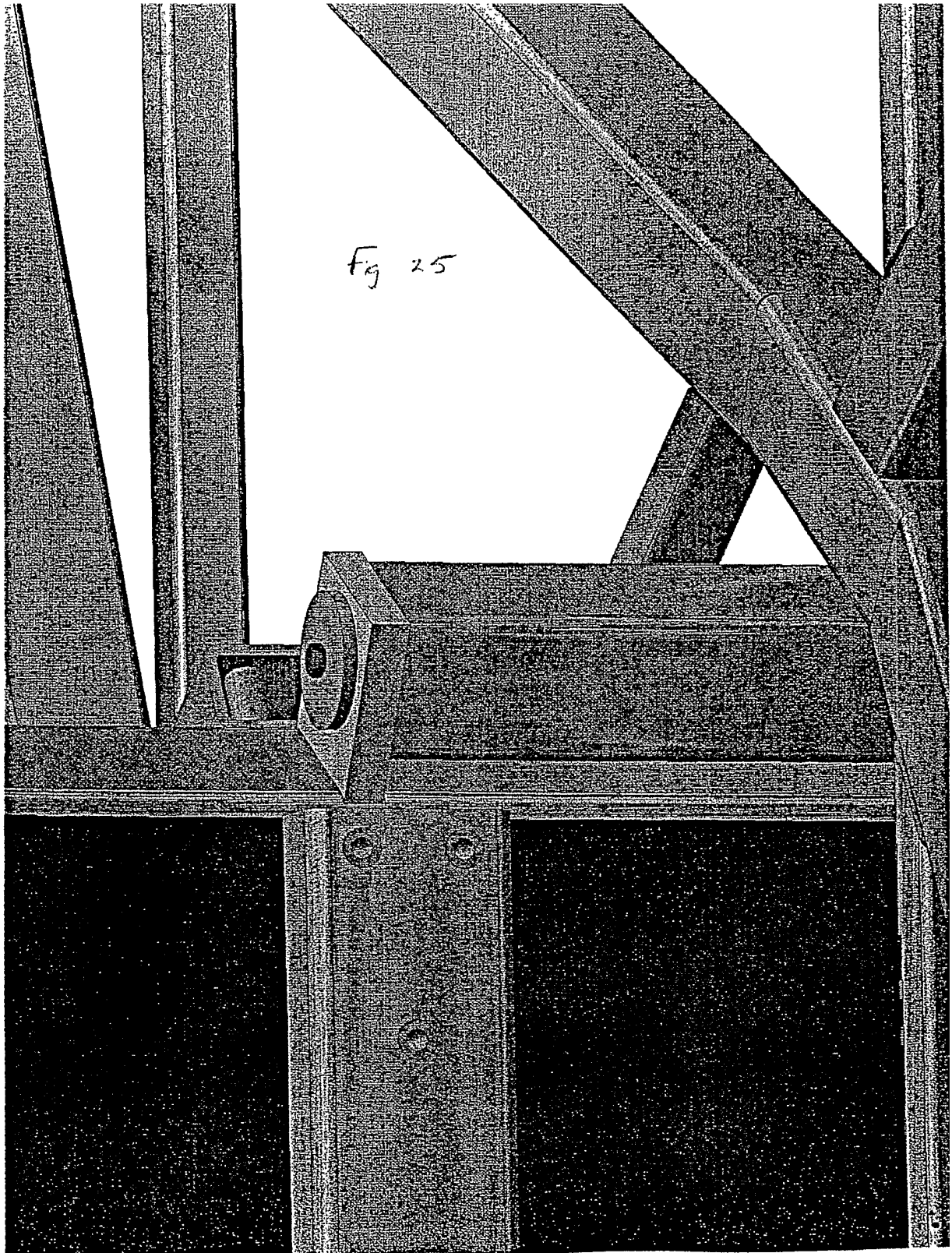

Fig. 26a

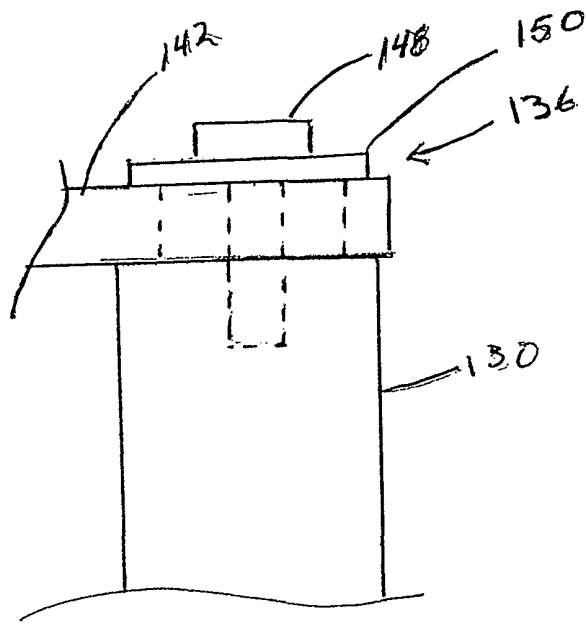
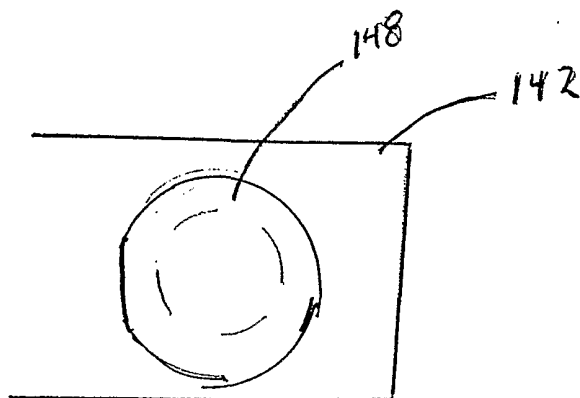

Fig. 26b



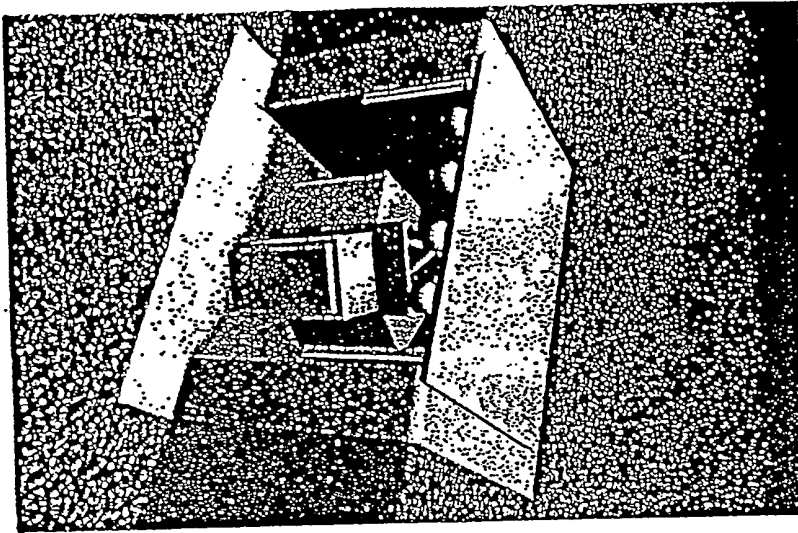

Figure 27a

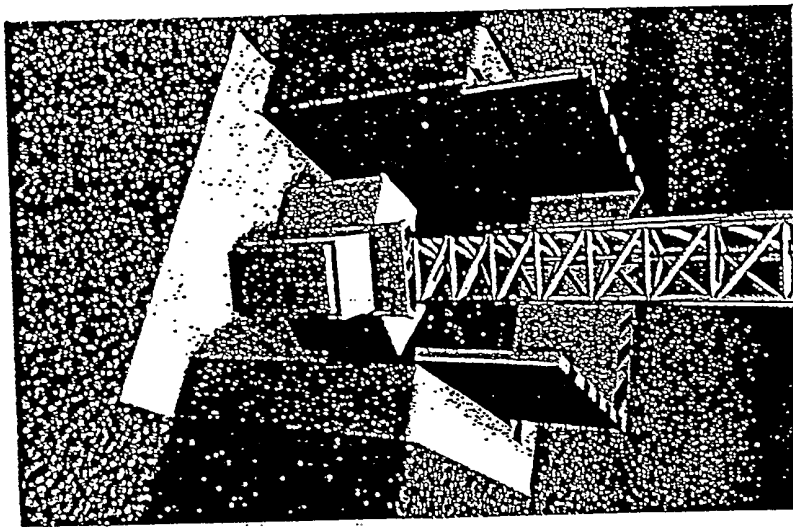

Figure 27b

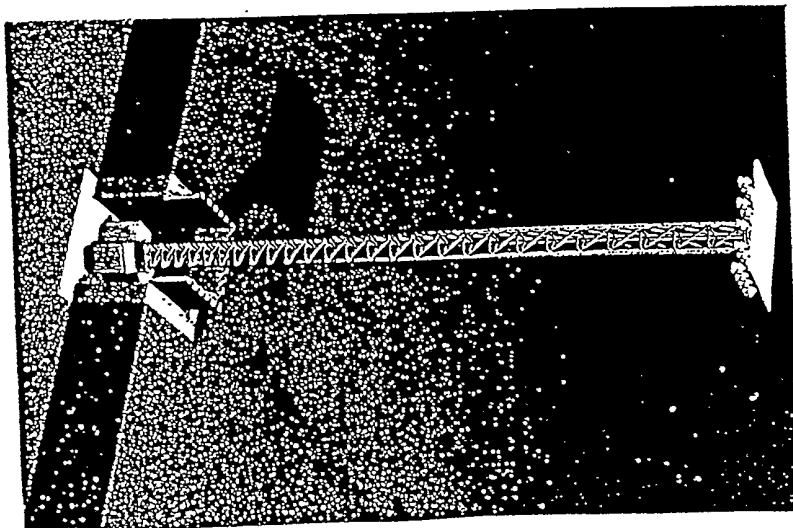

Figure 27c

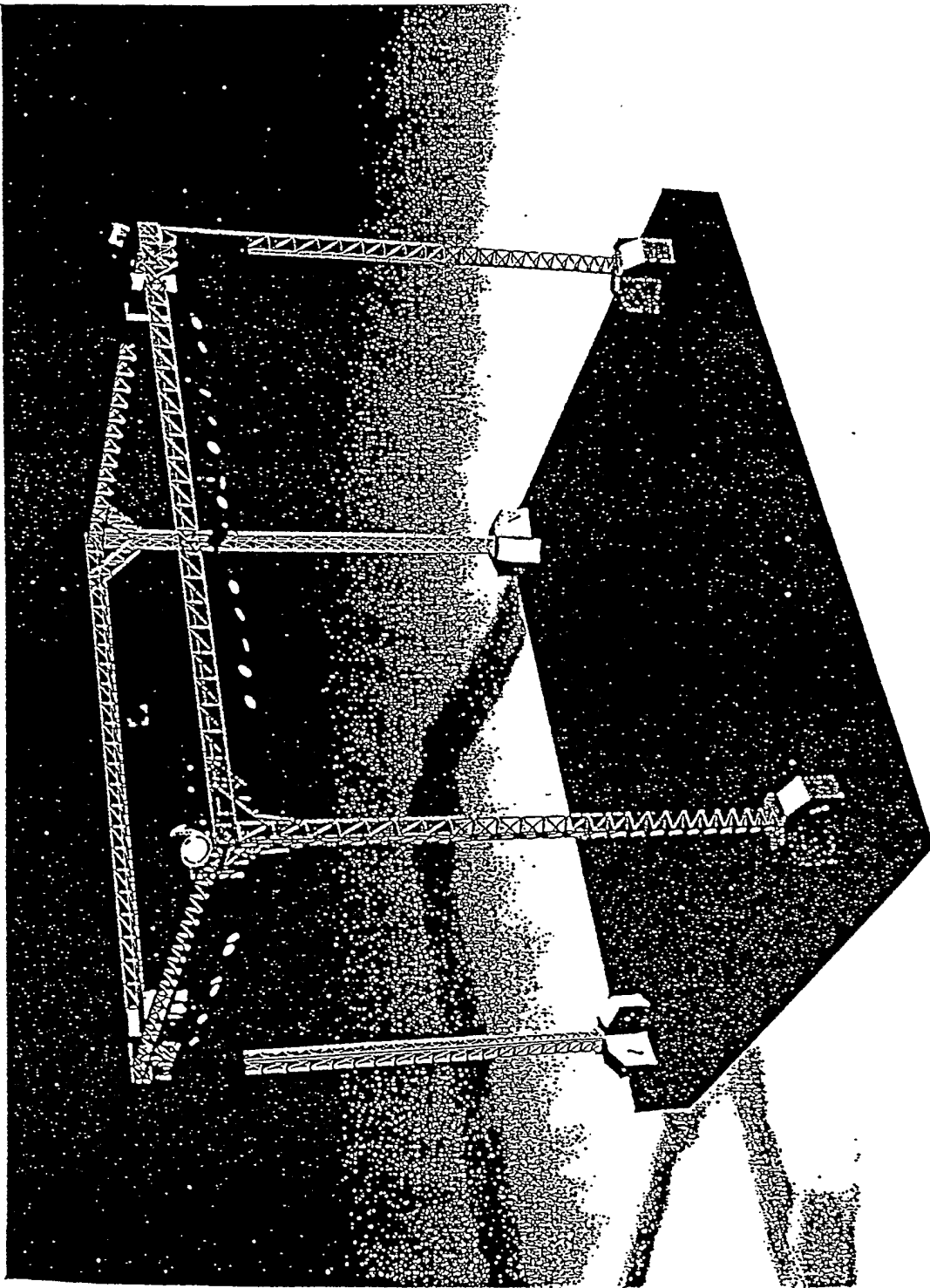

Figure 28

