

(19)  
(12)

(KR)  
(B1)

(51) 。 Int. Cl.<sup>7</sup>  
H02K 7/116

(45)  
(11)  
(24)

2004 11 10  
10-0456917  
2004 11 03

(21) 10-2002-0009814  
(22) 2002 02 25

(65)  
(43)

10-2002-0070811  
2002 09 11

(30) JP-P-2001-00058331 2001 03 02 (JP)

(73) 가 가  
가 5329

(72) 가 5239 가 가

(74)

:

(54)

AC  
(11) (11c) (15a) (15b)  
(N,S) (N,S)  
(N,S) (11m) (11k) , (N,S) (11Nc,11Sc)  
(15a) 가 ,  
(11Nc,11Sc) (15b)

4

1  
2  
3  
4  
5 4  
6  
7 6  
8 (a)

(a) , (b)  
(a) , (b)

, (b)

AC  
(100)

가

8(b)

AC  
(w)

AC

8(b)  
(101)  
8(a)

(100)가

(100)

가  
가

(103)  
(104N)(104S) (102)

(102)

가

(104N)(104S) (w)  
(102) (w)

가 (102)

가

가

가가

가

가 가

AC

AC

가

가가

가

( ) 1

AC (10) (11)가 2 1 (12), (13)

(14) 2 1

3 1 2 AC (10) (11) (11)가 (15)( 2 ) (11)

AC (10) (16) (17) (16) (12) (11)

(13) (14) (18) AC (

10) (19) (16) (30)( 2 ) (11)

(11) (11a) (11b)가 ( 3 ), (11)

(24) (20) (20a) (20a)가 (11) (11b)

(20) 가 (21) (20) 가 (22) (22a)

(20) (22a) (21) 가 (20) (11)

(20a) (11) (22b)

(22) (22a) (22c) (

24) (22) (16) (16a) (16b)

) (22d) (16a) (16b)

(11b) (22d)가 (22) (22a) (11a) (20)

(15)가 (11b) (20a) (17) (17a)

(11) (20) (17) (17b) (23) (16a) (16)

(17c) (17a) (17d)

(17e) (17e) (17f) (14)

(14a) (14a) (14b) (26b) (26)

(13) (13a) (27) 가 (28)

( 1 ) (13) (11) (28) (28)

(27) 가 (26) (26a) 가 (26a) (28)

26) (14) (17) (17f) (17e)

(17c) (17c) (17) (17b)

(12) (23) (23b) (23c) (16a)

(16a)가 (16b) (22d)

(22)가 (20) (11b)

(20a) (20) 가 (12)

가 (20) (16) (21) 가 (20)

(20b)가 (22) (20)

(11)가 (28a) (26) (26a) (13) (28) (27) 가 (17)

(17f) (17e) (17b) 가 (17) (20) (12)

(17d)가 (16) (17b) (12)

(15) (11) (13) (28)

(27) 가 (26) (17d) (14)

(16) (17d)

(17c)가 , (17f)가 (14) (26) (1  
6) (16) (16a) (16b)  
(22d) (22) (22a) (22b) (20)  
(11b) (20a) (15) (16) (30)  
(16b) (11)  
(13) ,  
가 가  
가 ,  
(閉止) AC (10) (11)가 (11)  
3 (24)( 1 ) (24a) (11a) (Nd-Fe-B) (11c)가  
(11c) (11d) (13b)  
(11a) (11d) (13c) , 가 (11) (1  
1a) (13) (11) (13) (13a) (13d)  
(11e) , (11a) (13) (11f)가  
4 (13) (11) 4(a)  
4(b) (a) B-B (11) (11) (N,S)  
(N,S) (15) (15a) (15b) , AC (10)  
가 (11N,11S) (W) 5(b) (H)  
4(a) (11m) (11k) (11) 가 (11c)  
(11Nc,11Sc)  
1N,11S) (11c) (W) (15) (15a) (11c) (15b) 가 (1  
(11Nc,11Sc) (C) 5(a)  
(F) (11) (11c) (Np, Sp)  
(15)가 (15b) (Np,Sp) (11Nc,11Sc) (11Nc,11Sc)  
(15) (11)  
6 (b) (a) B-B 2 (11-1) 6(a) 6  
1 (11Nc,11Sc) (11-1)  
6(a) (C)  
(Np, Sp) (15) (F) 가  
2 (11Nc-1,11Sc-1) (11m-1) (11k-1)  
(11Nc-1,11Sc-1) (11Nc-1,11Sc-1)  
(11) (11-1) (11N  
c-1,11Sc-1) (C-1) 7(b) (F-1)

가

1  
가

1

(57)

1.

가

2.

1

3.

가

4.

3

가

1

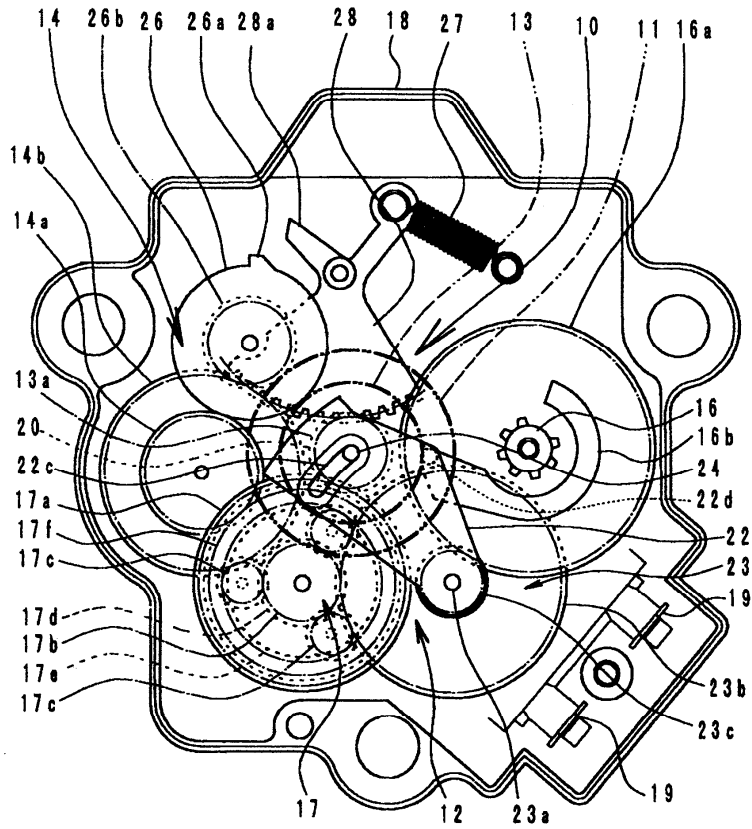

2

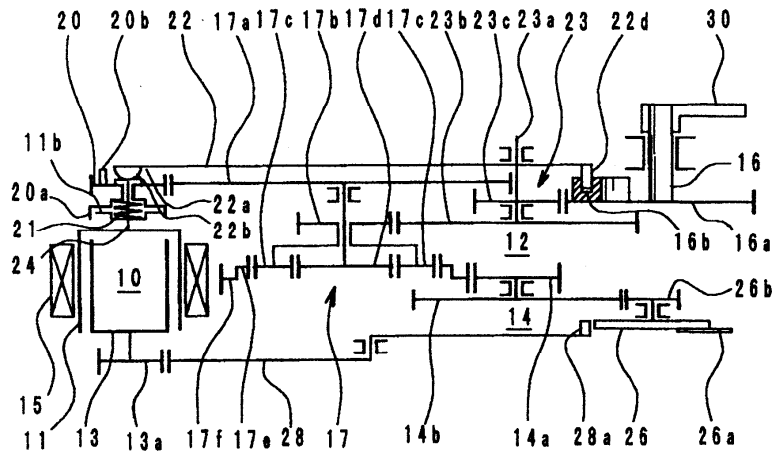

3

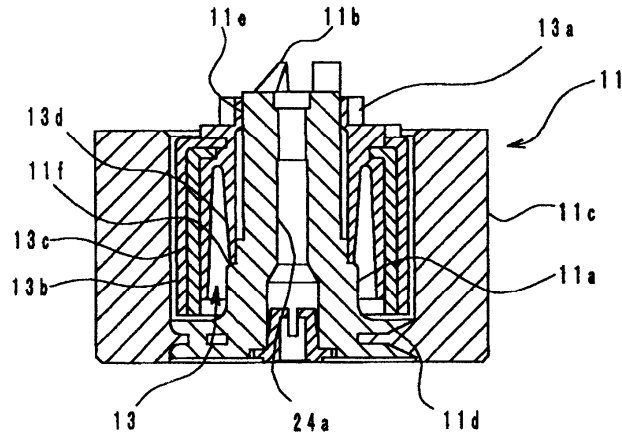

4

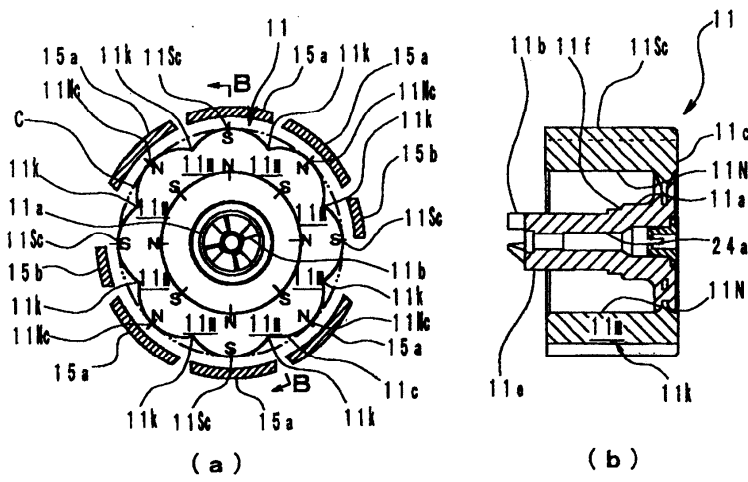

5

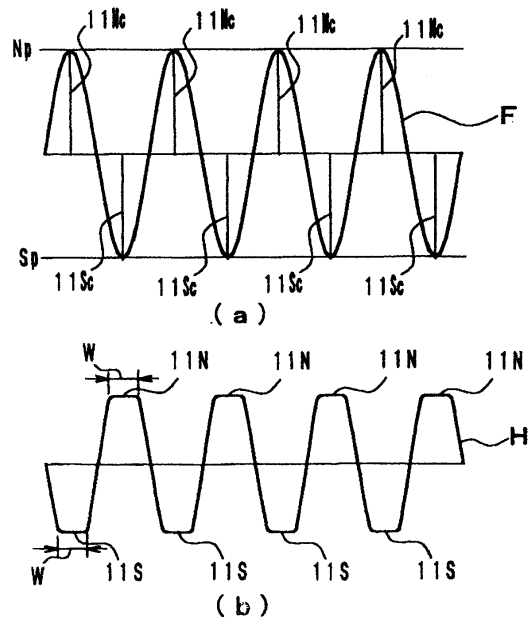

6

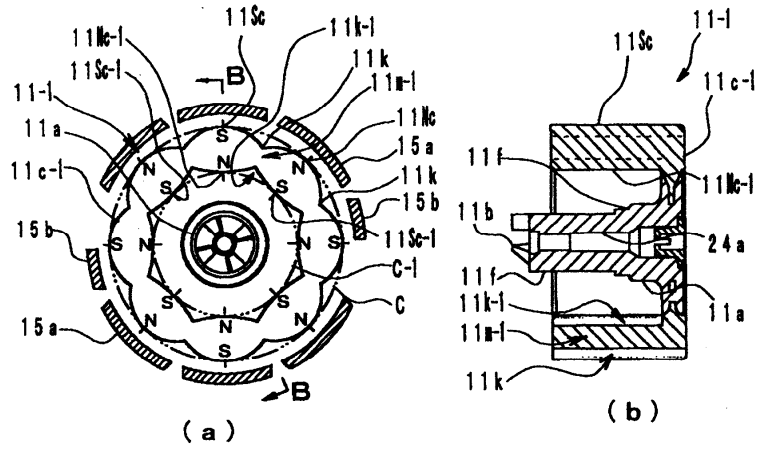

7

