

(19)



(11)

**EP 3 971 494 B1**

(12)

**EUROPEAN PATENT SPECIFICATION**

(45) Date of publication and mention of the grant of the patent:  
**27.12.2023 Bulletin 2023/52**

(51) International Patent Classification (IPC):  
**F25B 41/00** <sup>(2021.01)</sup> **F24F 1/32** <sup>(2011.01)</sup>  
**F16K 27/00** <sup>(2006.01)</sup>

(21) Application number: **19928505.7**

(52) Cooperative Patent Classification (CPC):  
**F25B 41/40; F24F 1/32; F25B 13/00; F25B 41/20; F25B 2313/006; F25B 2313/0231; F25B 2313/0272; F25B 2700/1931; F25B 2700/1933**

(22) Date of filing: **16.05.2019**

(86) International application number:  
**PCT/JP2019/019539**

(87) International publication number:  
**WO 2020/230321 (19.11.2020 Gazette 2020/47)**

(54) **AIR CONDITIONING DEVICE**

KLIMATISIERUNGSVORRICHTUNG

DISPOSITIF DE CLIMATISATION

(84) Designated Contracting States:  
**AL AT BE BG CH CY CZ DE DK EE ES FI FR GB GR HR HU IE IS IT LI LT LU LV MC MK MT NL NO PL PT RO RS SE SI SK SM TR**

(72) Inventor: **BABA, Yohei**  
**Tokyo 100-8310 (JP)**

(43) Date of publication of application:  
**23.03.2022 Bulletin 2022/12**

(74) Representative: **Witte, Weller & Partner**  
**Patentanwälte mbB**  
**Postfach 10 54 62**  
**70047 Stuttgart (DE)**

(73) Proprietor: **mitsubishi electric corporation**  
**Chiyoda-ku**  
**Tokyo 100-8310 (JP)**

(56) References cited:  
**JP-A- H04 217 760 JP-A- H06 137 591**  
**JP-A- 2002 277 003 JP-A- 2005 326 090**  
**JP-B2- 3 132 198 KR-A- 20150 072 991**  
**US-A1- 2012 031 130**

**EP 3 971 494 B1**

Note: Within nine months of the publication of the mention of the grant of the European patent in the European Patent Bulletin, any person may give notice to the European Patent Office of opposition to that patent, in accordance with the Implementing Regulations. Notice of opposition shall not be deemed to have been filed until the opposition fee has been paid. (Art. 99(1) European Patent Convention).

## Description

### Technical Field

**[0001]** The present disclosure relates to an air-conditioning apparatus including a relay unit installed between an outdoor unit and an indoor unit.

### Background Art

**[0002]** In an air-conditioning apparatus, refrigerant that carries heat is circulated through pipes that connects an outdoor unit and an indoor unit, to thereby generate conditioned air.

**[0003]** Recently, air-conditioning apparatuses capable of simultaneously performing cooling and heating have been developed. In such a kind of an air-conditioning apparatus, a plurality of indoor units are installed, and a relay unit is thus installed between an outdoor unit and the indoor units. The relay unit distributes refrigerant to the indoor units.

**[0004]** For example, an air-conditioning apparatus disclosed in Patent Literature 1 is an existing air-conditioning apparatus capable of simultaneously performing cooling and heating. The air-conditioning apparatus of Patent Literature 1 includes a heat source unit that operates as an outdoor unit, a plurality of indoor units, and a relay unit that is installed between the heat source unit and the indoor units. The relay unit of the air-conditioning apparatus has a plurality of branch ports that allow the relay unit to be connected to the respective indoor units.

**[0005]** In such a kind of air-conditioning apparatus, in general, the branch ports of the relay unit are connected using flare nuts to pipes that are installed at an actual place and connected to the indoor units. Each of the branch ports of the relay unit is formed such that a joint is brazed to a copper pipe. Each of the pipes at the actual place includes a flare nut provided at one end of each pipe. The flare nut of the pipe at the actual place is screwed onto the joint of the branch port using a spanner, whereby the pipe at the actual place is connected to the branch port of the relay unit.

**[0006]** Patent Literature 2, according to its abstract, states that, to resolve a problem in a conventional branch unit of a refrigerant circuit wherein maintainability is bad even when it is grounded in an underpart of a roof, under a floor, or in a high place, in the refrigerant circuit branch unit or the air conditioner, a single outdoor unit and a plurality of indoor units are connected by the refrigerant circuit via the branch unit, and refrigerant is supplied from the outdoor unit to the plurality of indoor units via the branch unit. The branch unit is composed of a casing composed of a lid body wherein a top face and a bottom face can be attached and detached.

**[0007]** Patent Literature 3, according to its abstract, states that, to minimize time for mounting and removing a refrigerant branching box by making joints capable of being easily connected and disconnected by providing a

plurality of refrigerant outlet pipes having greater lengths in proportion to their distances from an access cover, Outlet side pipes and an inlet side pipe are protruded from one side face of a main body of a refrigerant branching box: length differences (m) and (n) are provided between the outlet side pipes making the length of the pipes greater in proportion to their distances from an access cover of a container part for the refrigerant branching box. In relation to the access cover closing the container part the refrigerant branching box is contained such as to occupy a space close toward the side end. Joints can be easily connected and disconnected by a wrench without interference with the outlet side pipes.

### 15 Citation List

#### Patent Literature

#### **[0008]**

Patent Literature 1: Japanese Patent No. 3235189

Patent Literature 2: JP 2005 326090 A

Patent Literature 3: JP 3 132 198 B2

### 20 25 Summary of Invention

#### Technical Problem

**[0009]** In such an existing air-conditioning apparatus as described above, in a connection work of connecting the pipes at the actual place to the branch ports of the relay unit, each of the flare nuts is tightened while a hexagonal portion of an associated one of the joints is being fastened with a spanner. However, since liquid pipes and gas pipes are installed as the pipes at the actual place, the relay unit are formed to have a plurality of branch ports for the pipes at the actual place. Thus, the distance between any adjacent two of the branch ports in the relay unit is short. Therefore, in such a connection work as described above, when a pipe at the actual place is connected to an associated branch port of the relay unit, this connection may be obstructed by another branch port. If so, a spanner cannot be engaged with the hexagonal portion of the joint at an appropriate angle. In such a case, if the spanner is forcedly moved in such a manner as to apply a force to the hexagonal portion of the joint, the spanner may be slipped, thus deforming the joint. Consequently, a crack may be formed at the brazed portion of the joint, causing a leak of refrigerant.

**[0010]** The present invention is applied to solve the above problem, and relates to an air-conditioning apparatus that enables the workability of a connection work of connecting a relay unit to pipes connected to an indoor unit to be improved.

### 55 Solution to Problem

**[0011]** Therefore, there is provided an air-conditioning

apparatus according to independent claim 1.

#### Advantageous Effects of Invention

**[0012]** In the air-conditioning apparatus, it is possible to improve the workability of a connection work of connecting the relay unit to pipes connected to the indoor unit.

#### Brief Description of Drawings

##### **[0013]**

[Fig. 1] Fig. 1 is a diagram illustrating a configuration of an air-conditioning apparatus according to Embodiment 1.

[Fig. 2] Fig. 2 is a perspective view of the entire configuration of a relay unit included in the air-conditioning apparatus according to Embodiment 1.

[Fig. 3] Fig. 3 is a partial side view illustrating a configuration of each of refrigerant supply pipes of the relay unit in Embodiment 1.

[Fig. 4] Fig. 4 is a partial side view of the configuration of another example of the refrigerant supply pipe of the relay unit in Embodiment 1.

[Fig. 5] Fig. 5 is a diagram illustrating a spanner engaged with a joint included in the refrigerant supply pipe as illustrated in Fig. 4.

[Fig. 6] Fig. 6 is a partial side view illustrating a configuration of each of refrigerant supply pipes of a relay unit of a reference example.

[Fig. 7] Fig. 7 is a partial side view illustrating a configuration of a joint included in the refrigerant supply pipe of the relay unit of the reference example.

[Fig. 8] Fig. 8 is a diagram illustrating the joint included in the refrigerant supply pipe of the relay unit of the reference example in the case where the joint is deformed.

[Fig. 9] Fig. 9 is a diagram illustrating the spanner engaged with the joint in the reference example as illustrated in Fig. 7.

#### Description of Embodiments

**[0014]** An embodiment of an air-conditioning apparatus according to the present invention will be described with reference to the drawings.

##### Embodiment 1

**[0015]** An air-conditioning apparatus according to Embodiment 1 includes a plurality of indoor units and is capable of performing a cooling only operation, a heating only operation, and a simultaneous cooling and heating operation. Fig. 1 illustrates a configuration of an air-conditioning apparatus 100 according to Embodiment 1. The air-conditioning apparatus 100 includes an outdoor unit 51, indoor units 52a and 52b, and a relay unit 53. The

relay unit 53 is installed between the outdoor unit 51 and the indoor units 52a and 52b.

**[0016]** The outdoor unit 51 and the relay unit 53 are connected by a first liquid pipe 104 through which liquid refrigerant flows and a first gas pipe 103 through which gas refrigerant flows.

**[0017]** The relay unit 53 and the indoor unit 52a are connected by a second liquid pipe 105a through which the liquid refrigerant flows and a second gas pipe 106a through which the gas refrigerant flows. Similarly, the relay unit 53 and the indoor unit 52b are connected by a second liquid pipe 105b through which the liquid refrigerant flows and a second gas pipe 106b through which the gas refrigerant flows.

**[0018]** Although the air-conditioning apparatus 100 according to Embodiment 1 is an air-conditioning apparatus in which the indoor units 52a and 52b can perform a cooling operation or a heating operation independently of each other, Embodiment 1 is not limited to this example. In other words, Embodiment 1 is applicable to any type of air-conditioning apparatus as long as the air-conditioning apparatus includes the relay unit 53.

**[0019]** Components included in the air-conditioning apparatus 100 will be described.

##### [Outdoor Unit 51]

**[0020]** The outdoor unit 51 includes a compressor 1, a four-way valve 3, an outdoor heat exchanger 2, an accumulator 4, a refrigerant flow control unit 54, and an outdoor-side control unit 201. The compressor 1 sucks, compresses, and discharges refrigerant. As the compressor 1, a device whose capacity is controlled to change the amount of refrigerant to be sent per unit time, such as an inverter circuit, can be used. On a discharge side of the compressor 1, a first pressure sensor 31 is provided, and on a suction side of the compressor 1, a second pressure sensor 32 is provided. The first pressure sensor 31 detects a pressure  $P_d$  of discharged refrigerant. The second pressure sensor 32 detects a pressure  $P_s$  of refrigerant to be sucked into the compressor 1. The pressure  $P_d$  detected by the first pressure sensor 31 and the pressure  $P_s$  detected by the second pressure sensor 32 are transmitted as data to the outdoor-side control unit 201. The outdoor-side control unit 201 operates as a controller that performs a centralized control of the entire air-conditioning apparatus.

**[0021]** The outdoor heat exchanger 2 causes refrigerant to flow therein and causes heat exchange to be performed between the refrigerant and outdoor air. In the heating operation, the outdoor heat exchanger 2 operates as an evaporator to evaporate and gasify the refrigerant. In the cooling operation, the outdoor heat exchanger 2 operates as a condenser to condense and liquefy the refrigerant. The four-way valve 3 is a valve that switches the flow of the refrigerant between flows of the refrigerant for respective operations. That is, when the four-way valve 3 switches the flow of the refrigerant, the

operation is switched between, for example, the cooling operation and the heating operation. The accumulator 4 accumulates an excess of liquid refrigerant. The refrigerant flow control unit 54 includes check valves 7a, 7b, 7c, and 7d, which will be described later, and each of which permits the refrigerant to flow only in one direction.

[Refrigerant Flow Control Unit 54]

**[0022]** The refrigerant flow control unit 54 includes four connection pipes 130, 131, 132, and 133 that connect connection points a, b, c, and d and the four check valves 7a, 7b, 7c, and 7d each of which permits the refrigerant to flow in one direction. The refrigerant flow control unit 54 is one of the components of the outdoor unit 51. The connection pipe 130 is a pipe that connects the connection point c and the connection point a. The connection pipe 131 is a pipe that connects the connection point d and the connection point b. The connection pipe 132 is a pipe that connects the connection point c and the connection point d. The connection pipe 133 is a pipe that connects the connection point a and the connection point b. Furthermore, the connection pipe 132 connects the first gas pipe 103 connected to the relay unit 53 and a third gas pipe 102 connected to the compressor 1. In addition, the connection pipe 133 connects the first liquid pipe 104 connected to the relay unit 53 and a third liquid pipe 101 connected to the compressor 1.

**[0023]** The check valve 7a is provided at the connection pipe 132 and permits the refrigerant to flow in a direction from the connection point c toward the connection point d. The check valve 7b is provided at the connection pipe 133 and permits the refrigerant to flow in a direction from the connection point a toward the connection point b. The check valve 7c is provided at the connection pipe 131 and permits the refrigerant to flow in a direction from the connection point d toward the connection point b. The check valve 7d is provided at the connection pipe 130 and permits the refrigerant to flow in a direction from the connection point c toward the connection point a.

[Indoor Units 52a and 52b]

**[0024]** The indoor unit 52a includes an indoor heat exchanger 5a, an indoor expansion device 6a, and an indoor-side control unit 202a. The indoor unit 52b includes an indoor heat exchanger 5b, an indoor expansion device 6b, and an indoor-side control unit 202b. The second gas pipe 106a is connected to one end of the indoor heat exchanger 5a. The second gas pipe 106b is connected to one end of the indoor heat exchanger 5b. The indoor heat exchangers 5a and 5b each cause refrigerant that has passed through the relay unit 53 to flow therein, and cause heat exchange to be performed between the refrigerant and air to be conditioned. In the heating operation, the indoor heat exchangers 5a and 5b each operate as a condenser to condense and liquefy the refrigerant. In the cooling operation, the indoor heat exchangers 5a

and 5b each operate as an evaporator to evaporate and gasify the refrigerant. The other end of the indoor heat exchanger 5a is connected to the indoor expansion device 6a. The other end of the indoor heat exchanger 5b is connected to the indoor expansion device 6b. The indoor expansion device 6a is connected to the second liquid pipe 105a. The indoor expansion device 6b is connected to the second liquid pipe 105b. The indoor expansion devices 6a and 6b each operate as a pressure reducing valve and an expansion valve to reduce the pressure of the refrigerant and expand the refrigerant. Each of the indoor expansion devices 6a and 6b is only required to be capable of adjusting the pressure of the refrigerant, depending on an air-conditioning load. For example, as each of the indoor expansion devices 6a and 6b, a flow control device, such as an electronic expansion valve, can be used. In the indoor unit 52a, a first temperature sensor 33a and a second temperature sensor 34a are provided. In the indoor unit 52b, a first temperature sensor 33b and a second temperature sensor 34b are provided. The first temperature sensor 33a and the second temperature sensor 34a each detect the temperature of the refrigerant that flows into or out of the indoor heat exchanger 5a. The first temperature sensor 33b and the second temperature sensor 34b each detect the temperature of the refrigerant that flows into or out of the indoor heat exchanger 5b. The first temperature sensor 33a and the second temperature sensor 34a each transmit a signal indicating the detected temperature to the indoor-side control unit 202a. Furthermore, the first temperature sensor 33b and the second temperature sensor 34b each transmit a signal indicating the detected temperature to the indoor-side control unit 202b.

[Relay Unit 53]

**[0025]** The relay unit 53 includes a gas-liquid separator 8, first on-off valves 9a and 9b, second on-off valves 10a and 10b, a first expansion device 11, a second expansion device 12, a first heat exchanger 13, a second heat exchanger 14, check valves 15a, 15b, 16a, and 16b, and a relay-unit control unit 203. The components of the relay unit 53 are controlled by the relay-unit control unit 203. Furthermore, the components of the relay unit 53 are connected by a first bypass pipe 110, a first relay-unit liquid pipe 111, a first relay-unit gas pipe 112, and a second bypass pipe 113. The relay unit 53 is connected to the outdoor unit 51 by the first liquid pipe 104 and the first gas pipe 103. Furthermore, the relay unit 53 is connected to the indoor unit 52a by the second liquid pipe 105a and the second gas pipe 106a, and is connected to the indoor unit 52b by the second liquid pipe 105b and the second gas pipe 106b. The relay unit 53 controls the flow of the refrigerant between the outdoor unit 51 and each of the indoor units 52a and 52b. The indoor units 52a and 52b perform the simultaneous cooling and heating operation. The term "simultaneous cooling and heating operation" means an operation in which one of the

indoor units performs the cooling operation and the other performs the heating operation. Although Fig. 1 illustrates the two indoor units, the relay unit 53 can be connected to up to 16 indoor units 52 by increasing the number of on-off valves 9, that of on-off valves 10, that of check valves 15, and that of check valves 16. Also, although it is described by way of example that the maximum number of indoor units 52 that can be provided is 16, it is not limiting, and the maximum number of indoor units 52 may be any number larger than or equal to 1.

**[0026]** The gas-liquid separator 8 separates the refrigerant into liquid refrigerant and gas refrigerant, and is connected to the first liquid pipe 104, the first relay-unit liquid pipe 111, and the first relay-unit gas pipe 112. The first liquid pipe 104 connects the outdoor unit 51 and the gas-liquid separator 8. The first relay-unit liquid pipe 111 connects the gas-liquid separator 8 and each of the check valves 15a and 15b. The first relay-unit gas pipe 112 connects the gas-liquid separator 8 and each of the first on-off valves 9a and 9b.

**[0027]** The second gas pipe 106a branches and connects to the first on-off valve 9a and the second on-off valve 10a. Similarly, the second gas pipe 106b branches and connects to the first on-off valve 9b and the second on-off valve 10b. Each of the first on-off valves 9a and 9b is opened to permit the gas refrigerant that flows through the first relay-unit gas pipe 112 to flow out of the relay unit 53, or is closed to shut out the flow of the gas refrigerant. Each of the first on-off valves 9a and 9b is in the opened state while the indoor unit 52a or 52b connected to the valve by the second gas pipe 106a or 106b is in the heating operation. Each of the second on-off valves 10a and 10b is opened to permit gas refrigerant that flows from the second gas pipe 106a or 106b of the indoor unit 52a or 52b to flow into the relay unit 53, or is closed to shut out the flow of the gas refrigerant. Each of the second on-off valves 10a and 10b is in the opened state while the indoor unit 52a or 52b connected to the valve by the second gas pipe 106a or 106b is in the cooling operation. The second on-off valves 10a and 10b are connected to the first gas pipe 103.

**[0028]** The first heat exchanger 13 causes the liquid refrigerant separated by the gas-liquid separator 8 and liquid refrigerant that has passed through the second heat exchanger 14 to flow in the first heat exchanger 13, and cause heat exchange to be performed between the liquid refrigerants that flow in the first heat exchanger 13. The first expansion device 11 reduces the pressure of the liquid refrigerant that has passed through the first heat exchanger 13 and causes the refrigerant to flow into the second heat exchanger 14. The second heat exchanger 14 causes the refrigerant that has been reduced in pressure by the first expansion device 11 and liquid refrigerant that has been reduced in pressure by the second expansion device 12 to flow in the second heat exchanger 14, and cause heat exchange to be performed between the refrigerant and the liquid refrigerant that flow in the second heat exchanger 14. The first heat exchang-

er 13, the first expansion device 11, and the second heat exchanger 14 are interposed between the gas-liquid separator 8 and a relay-unit trifurcate portion 55, and are connected by the first relay-unit liquid pipe 111. The first bypass pipe 110 connects the relay-unit trifurcate portion 55 and the first gas pipe 103 via the second expansion device 12, the second heat exchanger 14, and the first heat exchanger 13. The first bypass pipe 110 collects liquid refrigerant and returns the liquid refrigerant to the outdoor unit 51. As the first expansion device 11 and the second expansion device 12, a flow control device whose opening degree can be changed to finely control the flow rate, such as an electronic expansion valve, may be used.

**[0029]** The check valve 16a permits the refrigerant to flow in a direction from the connection point f to the connection point e. The check valve 15a permits the refrigerant to flow in a direction from the connection point g to the connection point f. The check valve 16b permits the refrigerant to flow in a direction from the connection point h to the connection point e. The check valve 15b permits the refrigerant to flow in a direction from the connection point g to the connection point h. The first relay-unit liquid pipe 111 branches at the connection point g and connects to the check valves 15a and 15b. The second liquid pipe 105a branches at the connection point f and connects to the check valves 15a and 16a. The check valves 15a and 16a are connected to the second liquid pipe 105a such that refrigerant from the check valve 15a flows to the second liquid pipe 105a and refrigerant from the second liquid pipe 105a flows to the check valve 16a. Similarly, the second liquid pipe 105b branches at the connection point h and connects to the check valves 15b and 16b. The check valves 15b and 16b are connected to the second liquid pipe 105b such that refrigerant from the check valve 15b flows to the second liquid pipe 105b and refrigerant from the second liquid pipe 105b flows to the check valve 16b. The second bypass pipe 113 connects the first heat exchanger 13 and each of the check valves 16a and 16b. The second bypass pipe 113 branches at the connection point e and connects to the check valves 16a and 16b. The connection point g is connected to the first bypass pipe 110 and the first relay-unit liquid pipe 111 via the relay-unit trifurcate portion 55.

**[0030]** The configuration of the relay unit 53 in Embodiment 1 will be described with reference to Fig. 2. Fig. 2 is a perspective view of the entire configuration of the relay unit included in the air-conditioning apparatus according to Embodiment 1. Fig. 2 illustrates an appearance of the relay unit 53 that can be connected to up to 16 indoor units 52. As illustrated in Fig. 2, the relay unit 53 is formed in the shape of a cuboid. In other words, the relay unit 53 has an upper surface, a lower surface, and four side surfaces. Of the four side surfaces of the relay unit 53, one of two side surfaces that extend in a width direction will be referred to as "side surface A", and one of two side surfaces that extend in a longitudinal direction will be referred to as "side surface B". As illustrated in Fig. 2, the side surface A and the side surface B are

adjacent to each other and perpendicular to each other.

**[0031]** As illustrated in Fig. 2, at the side surface A, a second relay-unit gas pipe 141 and a second relay-unit liquid pipe 142 are provided. The second relay-unit gas pipe 141 and the second relay-unit liquid pipe 142 protrude outwardly from the side surface A in a direction perpendicular to the side surface A. The second relay-unit gas pipe 141 is joined by brazing to the first gas pipe 103 that extends as illustrated in Fig. 1. The second relay-unit liquid pipe 142 is joined by brazing to the first liquid pipe 104 (see Fig. 1).

**[0032]** As illustrated in Fig. 2, at the side surface B, 16 liquid-refrigerant supply pipes 143 and 16 gas-refrigerant supply pipes 144 are provided. The liquid-refrigerant supply pipes 143 and the gas-refrigerant supply pipes 144 protrude outwardly from the side surface B in a direction perpendicular to the side surface B. Each of the liquid-refrigerant supply pipes 143 is a first refrigerant supply pipe. Each of the gas-refrigerant supply pipes 144 is a second refrigerant supply pipe. To be more specific, a single first refrigerant supply pipe and a single second refrigerant supply pipe are provided as a single pair of refrigerant supply pipes. The single pair of refrigerant supply pipes are connected to a single indoor unit 52. Fig. 2 illustrates 16 pairs of refrigerant supply pipes, that is, 16 pairs of liquid-refrigerant supply pipes 143 and gas-refrigerant supply pipes 144. Thus, the relay unit 53 can be connected to up to 16 indoor units 52. However, as described above, each of the number of liquid-refrigerant supply pipes 143 and the number of gas-refrigerant supply pipes 144 is not limited to 16 and may be any number as long as it is larger than or equal to the number of indoor units 52 to which the relay unit is connected. The liquid-refrigerant supply pipes 143 are connected by flare nuts to the second liquid pipes 105a and 105b that extend as illustrated in Fig. 1. Furthermore, the gas-refrigerant supply pipes 144 are connected by flare nuts to the second gas pipes 106a and 106b that extend as illustrated in Fig. 1. The liquid-refrigerant supply pipes 143 are located above the gas-refrigerant supply pipes 144. Each of the liquid-refrigerant supply pipes 143 may be offset rightwards or leftwards from an associated one of the gas-refrigerant supply pipes 144 only by a predetermined distance, not directly above the associated gas-refrigerant supply pipe 144. The relay unit 53 further includes a hanging lug 145. When installed, the relay unit 53 is hung with the hanging lug 145, using, for example, hanging bolts in a space above a ceiling in a building, for example. Hereinafter, a direction in which the liquid-refrigerant supply pipes 143 and the gas-refrigerant supply pipes 144 extend, or the direction perpendicular to the side surface B, will be referred to as "axial direction" of the liquid-refrigerant supply pipes 143 and the gas-refrigerant supply pipes 144. Therefore, the axial direction is a horizontal direction when the relay unit 53 is hung.

**[0033]** In the case where the two indoor units 52a and 52b are installed, as described above, two liquid-refrigerant supply pipes 143 are connected to respective sec-

ond liquid pipes, that is, the second liquid pipes 105a and 105b, and two gas-refrigerant supply pipes 144 are connected to respective gas pipes, that is, the second gas pipes 106a and 106b. However, in order that the above configuration be simply described, the following description is made with respect to an example in which a single liquid-refrigerant supply pipe 143 is connected to the second liquid pipe 105a, and a single gas-refrigerant supply pipe 144 is connected to the second gas pipe 106a. That is, a description concerning the second liquid pipe 105b and the second gas pipe 106b will be omitted. Figs. 6 to 9 illustrate a relay unit 53R as a reference example to be referred to in an explanation of advantages of Embodiment 1. Similarly, a description concerning the configuration as illustrated in Figs. 6 to 9 will also be simplified and made with respect to an example in which a liquid-refrigerant supply pipe 143R is connected to the second liquid pipe 105a, and a gas-refrigerant supply pipe 144R is connected to the second gas pipe 106a. That is, regarding the configuration as illustrated in each of Figs. 6 to 9, a description concerning the second liquid pipe 105b and the second gas pipe 106b will be omitted.

**[0034]** Fig. 6 is a partial side view illustrating the configuration of each of the refrigerant supply pipes of the relay unit of the reference example. Fig. 6 is a side view of the relay unit 53R of the reference example as viewed side-on with respect to the side surface A. As illustrated in Fig. 6, the liquid-refrigerant supply pipe 143R and the gas-refrigerant supply pipe 144R protrude from the side surface B. The liquid-refrigerant supply pipe 143R is provided above the gas-refrigerant supply pipe 144R. The length L1 of a protruding portion of the liquid-refrigerant supply pipe 143R is less than or equal to the length L2 of that of the gas-refrigerant supply pipe 144R. The liquid-refrigerant supply pipe 143R includes a first pipe 161aR fixed to the side surface B of the relay unit 53R and a liquid-pipe joint 151aR located at a distal end of the first pipe 161aR. The liquid-pipe joint 151aR is a first joint. The liquid-pipe joint 151aR is connected to the second liquid pipe 105a using a liquid-pipe flare nut 152aR. The liquid-pipe flare nut 152aR is provided at a distal end of the second liquid pipe 105a. The gas-refrigerant supply pipe 144R includes a second pipe 161bR fixed to the side surface B of the relay unit 53R and a gas-pipe joint 151bR jointed at a distal end of the second pipe 161bR. The gas-pipe joint 151bR is a second joint. The gas-pipe joint 151bR is connected to the second gas pipe 106a using a gas-pipe flare nut 152bR. The gas-pipe flare nut 152bR is provided at a distal end of the second gas pipe 106a.

**[0035]** Fig. 7 is a partial side view illustrating a configuration of the joint provided in the refrigerant supply pipe of the relay unit in the reference example. Fig. 7 illustrates a configuration of the liquid-pipe joint 151aR of the reference example as illustrated in Fig. 6. As illustrated in Fig. 7, the liquid-pipe joint 151aR includes a first portion 155R that is a hexagonal pipe and a second portion 156R to be fitted in the liquid-pipe flare nut 152aR. Since the

first portion 155R is the hexagonal pipe, the first portion 155R has six outer side surfaces and six outer corners. An end of the first portion 155R in the axial direction is brazed and fixed to the first pipe 161aR of the liquid-refrigerant supply pipe 143R. This brazed portion will hereinafter be referred to as "brazed portion 154R". The outside diameter of the first portion 155R is larger than that of the second portion 156R. The second portion 156R is formed in the shape of a circular tube, and a distal end portion of the second portion 156R is tapered toward a distal end of the distal end portion.

**[0036]** Connection of the liquid-refrigerant supply pipe 143R of the relay unit 53R to the second liquid pipe 105a using the liquid-pipe flare nut 152aR will be described. Since the relay unit 53R is hung in a space above a ceiling, a spanner is engaged with the liquid-pipe joint 151aR from below the relay unit 53R to fasten the liquid-pipe joint 151aR, and the liquid-pipe flare nut 152aR is tightened using a torque wrench. Thus, the gas-refrigerant supply pipe 144R located below the liquid-refrigerant supply pipe 143R is an obstruction to a work of engaging the spanner with the liquid-pipe joint 151aR. That is, it is hard to engage the spanner with the liquid-pipe joint 151aR. In view of this point, the spanner is diagonally moved and engaged with the first portion 155R of the liquid-pipe joint 151aR, or is moved from above and engaged with the first portion 155R. In either case, the spanner is located to hold the first portion 155R of the liquid-pipe joint 151aR at an inappropriate angle. Figs. 8 and 9 illustrate a state in which the spanner is located to hold the first portion 155R. Fig. 8 is a diagram illustrating the joint included in the liquid-refrigerant supply pipe of the relay unit 53R of the reference example in the case where the joint is deformed. Fig. 9 is a diagram illustrating the state in which the spanner is located to hold the joint in the reference example as illustrated in Fig. 7. Fig. 8 illustrates the above state as viewed side-on with respect to the side surface B of the relay unit 53R. Fig. 9 illustrates the above state as viewed side-on view with respect to a side surface that is opposite to the side surface A of the relay unit 53R. As illustrated in Fig. 9, in the connection work, the first portion 155R of the liquid-pipe joint 151aR is held and fixed by a spanner 1000. In Figs. 8 and 9, arrows P each indicating a direction in which a force is applied to the liquid-pipe joint 151aR by the spanner 1000.

**[0037]** Fig. 8 illustrates a state in which the spanner 1000 is located to hold the first portion 155R of the liquid-pipe joint 151aR at an inappropriate angle and is slipped. Referring to Fig. 8, the spanner 1000 holds two opposite outer corners of the first portion 155R, not two opposite outer side surfaces of the first portion 155R. When the liquid-pipe flare nut 152aR is tightened while the spanner 1000 is kept located on the first portion 155R of the liquid-pipe joint 151aR at an inappropriate angle, an excessive force may be applied to the first portion 155R of the liquid-pipe joint 151aR, thus deforming the first portion 155R and the first pipe 161aR. Consequently, a crack may be

formed at the brazed portion 154R, causing a leak of the refrigerant.

**[0038]** In contrast, the above problem does not occur in the relay unit 53 according to Embodiment 1. Fig. 3 is a partial side view illustrating a configuration of each of the refrigerant supply pipes in the relay unit 53 of Embodiment 1. Fig. 3 illustrates the refrigerant supply pipes as viewed side-on with respect to the side surface A of the relay unit 53. As illustrated in Fig. 3, the liquid-refrigerant supply pipe 143 and the gas-refrigerant supply pipe 144 protrude from the side surface B in the direction perpendicular to the side surface B of the relay unit 53. The liquid-refrigerant supply pipe 143 is provided above the gas-refrigerant supply pipe 144. The length L1 of a protruding portion of the liquid-refrigerant supply pipe 143 is greater than the length L2 of that of the gas-refrigerant supply pipe 144. In an example as illustrated in Fig. 3, the length L1 of the protruding portion of the liquid-refrigerant supply pipe 143 is 120 mm. However, the length L1 is not limited to 120 mm. The length L1 may be appropriately set to fall within the range of, for example, 100 to 150 mm.

**[0039]** The liquid-refrigerant supply pipe 143 includes a first pipe 161a fixed to the side surface B of the relay unit 53 and a liquid-pipe joint 151a located at a distal end of the first pipe 161a. The liquid-pipe joint 151a is a first joint. The liquid-pipe joint 151a is connected to the second liquid pipe 105 using a liquid-pipe flare nut 152a. The gas-refrigerant supply pipe 144 includes a second pipe 161b fixed to the side surface B of the relay unit 53 and a gas-pipe joint 151b located at a distal end of the second pipe 161b. The gas-pipe joint 151b is a second joint. The gas-pipe joint 151b is connected to the second gas pipe 106 using a gas-pipe flare nut 152b.

**[0040]** The configuration of the liquid-pipe joint 151a in Embodiment 1 is basically the same as that in the reference example as illustrated in Fig. 7. That is, the liquid-pipe joint 151a of Embodiment 1 includes a first portion 155 that is a hexagonal pipe and a second portion 156 to be fitted in the liquid-pipe flare nut 152a. The first portion 155 and the second portion 156 are molded and formed integral with each other. Alternatively, the first portion 155 and the second portion 156 may be formed as separate portions, and then joined to each other. Since the second portion 156 is not illustrated in Fig. 3, the second portion 156R as illustrated in Fig. 7 or the second portion 156 as illustrated in Fig. 4, which will be described later, should be referred to. Since the first portion 155 is the hexagonal pipe, the first portion 155 has six outer side surfaces and six outer corners. The first portion 155 has a hexagonal outer peripheral portion and a circular inner peripheral portion. Furthermore, an end of the first portion 155 in the axial direction is brazed and fixed to the first pipe 161a of the liquid-refrigerant supply pipe 143. This brazed portion will hereinafter be referred to as "brazed portion 154". Since the brazed portion 154 is not illustrated in Fig. 3, the brazed portion 154R as illustrated in Fig. 7 or the brazed portion 154 as illustrated in

Fig. 4, which will be described later, should be referred to. The second portion 156 is provided at one of ends of the first portion 155 that is closer to the indoor unit 52a. The second portion 156 is connected to the indoor heat exchanger 5a of the indoor unit 52a by the second liquid pipe 105a and the indoor expansion device 6a. The second portion 156 is formed in the shape of a circular tube. A distal end portion of the second portion 156 is tapered toward a distal end of the distal end portion. Since the liquid-pipe flare nut 152a is screwed onto the second portion 156, an outer peripheral surface of the second portion 156 and an inner peripheral surface of the liquid-pipe flare nut 152a are processed to have threads as necessary. The outside diameter of the first portion 155 is larger than that of the second portion 156.

**[0041]** As is clear from the comparison between Figs. 3 and 6, the length L1 of the protruding portion of the liquid-refrigerant supply pipe 143 that protrudes from the side surface B in Embodiment 1 is greater than that of the protruding portion of the liquid-refrigerant supply pipe 143R of the reference example as illustrated in Fig. 6. In Embodiment 1, the length L1 of the liquid-refrigerant supply pipe 143 is, for example, double the length L1 of the liquid-refrigerant supply pipe 143R as illustrated in Fig. 6. The length L2 of the gas-refrigerant supply pipe 144 in Embodiment 1 is equal to the length L2 of the gas-refrigerant supply pipe 144R as illustrated in Fig. 6. Therefore, in Embodiment 1, as illustrated in Fig. 3, the length L1 of the liquid-refrigerant supply pipe 143 is greater than the length L2 of the gas-refrigerant supply pipe 144.

**[0042]** Because of provision of the above configuration, in Embodiment 1, the spanner 1000 is easily engaged with the first portion 155 of the liquid-pipe joint 151a from below the relay unit 53, and the liquid-pipe flare nut 152a is easily tightened. That is, when the spanner 1000 is moved and engaged with the first portion 155 of the liquid-pipe joint 151a from below the relay unit 53, the gas-refrigerant supply pipe 144 does not interfere with movement of the spanner 1000. The spanner 1000 can thus be engaged at an appropriate angle with the first portion 155 of the liquid-pipe joint 151a. It is therefore possible to prevent deformation of the first portion 155 of the liquid-pipe joint 151a and deformation of the liquid-refrigerant supply pipe 143. Also, it is therefore possible to prevent formation of a crack at the brazed portion 154 between the liquid-pipe joint 151a and the first pipe 161a of the liquid-refrigerant supply pipe 143, thus preventing occurrence of a leak of the refrigerant.

**[0043]** A method of setting the length L1 of the liquid-refrigerant supply pipe 143 as illustrated in Fig. 3 will be described. It should be noted that of the two ends of the first portion 155 of the liquid-pipe joint 151a in the axial direction, an end closer to the relay unit 53 will be referred to as "relay-unit-53-side end" and the other end will be referred to as "indoor-unit-52-side end". The length L1 may be set such that the distance from the side surface B to the indoor-unit-side end of the first portion 155 of

the liquid-pipe joint 151a is longer than the distance from the side surface B to the distal end of the gas-refrigerant supply pipe 144. To be more specific, as illustrated in Fig. 3, the difference between the distance from the side surface B to the indoor-unit-52-side end of the first portion 155 of the liquid-pipe joint 151a and the distance from the side surface B to the distal end of the gas-refrigerant supply pipe 144 is a distance D. Fig. 3 illustrates a state in which the gas-pipe flare nut 152b is fitted to the distal end of the gas-refrigerant supply pipe 144. Thus, strictly speaking, the position of the distal end of the gas-refrigerant supply pipe 144 is the position of one of ends of the gas-pipe flare nut 152b that is closer to the indoor unit 52. The distance D and the length L1 are set such that the distance D is longer than or equal to a predetermined first threshold Dth. As illustrated in Fig. 9, assuming that the spanner 1000 has a thickness T, the first threshold Dth is determined based on the thickness T of the spanner 1000. Specifically, it is preferable that the first threshold Dth be set to the value of the thickness T of the spanner 1000. For example, where the length S of the first portion 155 of the liquid-pipe joint 151a in the axial direction is 17 mm, the thickness T of a round spanner that is compliant with Japanese Industrial Standards (JIS) B 4630 is 8 mm. Thus, it suffices that the first threshold Dth is set to 8 mm, and the length L1 is set such that the distance D is longer than or equal to the first threshold Dth. When the length S of the first portion 155 of the liquid-pipe joint 151a is changed, the spanner 1000 to be used is also changed. Thus, needless to say, the thickness T of the spanner is changed. In this case also, it suffices that the first threshold Dth is appropriately set based on the thickness T of the changed spanner 1000, and the length L1 is set such that the distance D is longer than or equal to the first threshold Dth. Although in the above description, the spanner is used in the example described above, it is not limiting, and another tool may be used. If another tool is used, it suffices that the first threshold Dth is appropriately set based on the thickness T of the tool.

**[0044]** As illustrated in Fig. 2, in Embodiment 1, the liquid-refrigerant supply pipes 143 are arranged at regular intervals at the side surface B of the relay unit 53. When the spanner 1000 is used for a single liquid-refrigerant supply pipe 143, it is preferable that the spanner 1000 could be rotated without contacting another liquid-refrigerant supply pipe 143. It is therefore also preferable that any adjacent two of the liquid-refrigerant supply pipes 143 be arranged apart from each other by a distance longer than or equal to a predetermined second threshold Wth. As illustrated in Fig. 8, the spanner 1000 has a width W. The second threshold Wth is determined based on the width W of the spanner 1000. Specifically, it is preferable that the second threshold Wth be set to 1/2 of the width W of the spanner 1000. In such a manner, in the case where the distance between the adjacent liquid-refrigerant supply pipes 143 is set longer than or equal to the second threshold Wth, the spanner 1000

can be rotated without contacting another liquid-refrigerant supply pipe 143. The same is true of the gas-refrigerant supply pipes 144. In other words, it is preferable that any adjacent two of the gas-refrigerant supply pipes 144 be arranged apart from each other by a distance longer than or equal to the second threshold  $W_t$ . Although it is described above that the liquid-refrigerant supply pipes 143 are arranged at regular intervals, and the same is true of the gas-refrigerant supply pipes 144, it is not limiting. That is, it is not indispensable that the liquid-refrigerant supply pipes 143 are arranged at irregular intervals, and the gas-refrigerant supply pipes 144 are arranged at irregular intervals. Although the tool for use in the above example is the spanner, the tool is not limited to the spanner. Any other tool may be used. Regarding the second threshold  $W_{th}$ , if another tool is used, it suffices that the second threshold  $W_{th}$  is appropriately set based on the width  $W$  of the tool.

**[0045]** Fig. 4 is a partial side view of a configuration of another example of the refrigerant supply pipe of the relay unit 53 in Embodiment 1. Fig. 4 illustrates a liquid-pipe joint 151a of the refrigerant supply pipe in a modification of Embodiment 1. In the modification as illustrated in Fig. 4, the liquid-pipe joint 151a includes the first portion 155 that is a hexagonal pipe, the second portion 156 to be fitted in the liquid-pipe flare nut 152a, and a third portion 153 brazed to the first pipe 161a of the liquid-refrigerant supply pipe 143. Hereinafter, a portion that is brazed to the third portion 153 and the first pipe 161a of the liquid-refrigerant supply pipe 143 will be referred to as "brazed portion 154". The third portion 153 is located at one of ends of the first portion 155 that is closer to the relay unit 53. The second portion 156 is located at the other end of the first portion 155, that is, one of the ends of the first portion 155 that is closer to the indoor unit 52. The third portion 153 is formed in the shape of a circular tube. Thus, an outer circumferential portion and an inner circumferential portion of the third portion 153 are both circular. The shapes of the first portion 155 and the second portion 156 of the liquid-pipe joint 151a are basically the same as those of the first portion 155 and the second portion 156 of the liquid-pipe joint 151a in Embodiment 1. It should be noted that the outside diameter of the third portion 153 is smaller than that of the first portion 155. The outside diameter of the second portion 156 is smaller than that of the first portion 155. The outside diameter of the second portion 156 may be the same as or different from that of the third portion 153. As described above, the liquid-pipe joint 151a in the modification as illustrated in Fig. 4 includes the first portion 155, the second portion 156, and the third portion 153 that is formed in the shape of a circular tube.

**[0046]** As described above, in the modification as illustrated in Fig. 4, the third portion 153, which is brazed and fixed to the first pipe 161a of the liquid-refrigerant supply pipe 143 by the brazed portion 154, is formed in the shape of a circular tube, not a hexagonal tube. In Embodiment 1 as described above, the length  $S$  of the first portion 155

of the liquid-pipe joint 151a in the axial direction is 17 mm. In the modification as illustrated in Fig. 4, the length of the third portion 153 of the liquid-pipe joint 151a in the axial direction is 5 mm, and the length  $S$  of the first portion of the liquid-pipe joint 151a in the axial direction is 12 mm. Therefore, the sum of the length of the first portion 155 and the length of the third portion 153 in the modification is  $5 + 12 = 17$  mm, and is the same as the length of the first portion 155 in Embodiment 1. These widths are merely described as examples and are not limiting. The sum of the length of the first portion 155 and the length of the third portion 153 in the modification is the same as the length of the first portion 155 in Embodiment 1. The sum of the length of the first portion 155 and the length of the third portion 153 may be the same as or different from the length of the first portion 155 in Embodiment 1.

**[0047]** Advantages of the modification as illustrated in Fig. 4 will be described with reference to Figs. 5 and 9. Fig. 5 is a diagram illustrating the spanner located to hold the joint included in the refrigerant supply pipe as illustrated in Fig. 4. Fig. 5 illustrates the liquid-pipe joint 151a in the modification as illustrated in Fig. 4. Fig. 9 is a diagram illustrating the spanner located to hold the joint in the reference example as illustrated in Fig. 7. Fig. 9 illustrates the liquid-pipe joint 151aR in the reference example.

**[0048]** Fig. 9 illustrates the spanner 1000 located to hold the liquid-pipe joint 151aR in the reference example. Fig. 9 is a side view except for a hatched area, which is illustrated as a section. As illustrated in Fig. 9, in this example, the spanner 1000 is located close to the brazed portion 154R. Thus, if the first portion 155R of the liquid-pipe joint 151aR is deformed, this deformation easily affects the brazed portion 154R, and a crack may be formed in the brazed portion 154R. Furthermore, as is clear from the hatched area as illustrated as the section in Fig. 9, the spanner 1000 is located only on thin part of the first portion 155R of the liquid-pipe joint 151aR, as a result of which the first portion 155R may be easily deformed.

**[0049]** Fig. 5 illustrates the spanner 1000 located to hold the liquid-pipe joint 151a in the modification of Embodiment 1, which is illustrated in Fig. 4. Fig. 5 is a side view except for a hatched area, which is illustrated as a section. In Fig. 5, arrows  $P$  each indicate a direction in which a force is applied to the liquid-pipe joint 151a by the spanner 1000. As illustrated in Fig. 5, the liquid-pipe joint 151a in the modification includes the third portion 153 formed in the shape of a circular tube, as described with reference to Fig. 4. In this case, the spanner 1000 is located on the first portion 155 of the liquid-pipe joint 151a, but not on the third portion 153. Therefore, the distance between the brazed portion 154 and the spanner 1000 is longer than that in the reference example as illustrated in Fig. 9. Thus, even if the first portion 155 of the liquid-pipe joint 151a is deformed, this deformation does not affect the brazed portion 154. As is clear from the hatched area as illustrated as the section in Fig. 5,

the spanner 1000 is located on thick part of the first portion 155 of the liquid-pipe joint 151a. Accordingly, the first portion 155 is not easily deformed. Thus, it is possible to prevent formation of crack in the brazed portion 154, thus preventing occurrence of a leak of the refrigerant.

**[0050]** Although the liquid-pipe joint 151a is described above with reference to Figs. 4 and 5, the gas-pipe joint 151b may be also formed to have a third portion 153 formed in the shape of a circular tube. The following is a description concerning the case where the gas-pipe joint 151b is formed to have a third portion 153 formed in the shape of a circular tube. Since the configuration of the gas-pipe joint 151b is basically the same as that of the liquid-pipe joint 151a, the gas-pipe joint 151b formed in the above manner will also be described with reference to Figs. 4 and 5. In this description, reference signs 151a and 161a indicated in Figs. 4 and 5 are replaced by reference signs 151b and 161b. The gas-pipe joint 151b includes a first portion 155, a second portion 156, and a third portion 153. The first portion 155 of the gas-pipe joint 151b is provided at the distal end of the second pipe 161b. The second portion 156 of the gas-pipe joint 151b is provided at one of ends of the first portion 155 of the gas-pipe joint 151b that is closer to the indoor unit 52b, and is connected to the indoor heat exchanger 5b of the indoor unit 52b via the second liquid pipe 105b and the indoor expansion device 6b. The third portion 153 of the gas-pipe joint 151b is provided at an end portion of the first portion 155 of the gas-pipe joint 151b that is closer to the relay unit 53, and is brazed to the second pipe 161b of the gas-refrigerant supply pipe 144 by the brazed portion 154. Therefore, needless to say, in the case where the gas-pipe joint 151b includes the third portion 153, it is possible to obtain the same advantages as in the case where the liquid-pipe joint 151a includes the third portion 153.

**[0051]** As described above, the relay unit 53 of Embodiment 1 includes the liquid-refrigerant supply pipe 143, which is the first refrigerant supply pipe, and the gas-refrigerant supply pipe 144, which is the second refrigerant supply pipe. The liquid-refrigerant supply pipe 143 and the gas-refrigerant supply pipe 144 protrude from the side surface B of the relay unit 53, that is, from the same side surface. The liquid-refrigerant supply pipe 143 is provided above the gas-refrigerant supply pipe 144. The length L1 of the protruding portion of the liquid-refrigerant supply pipe 143 that protrudes from the side surface B is set longer than the length L2 of the protruding portion of the gas-refrigerant supply pipe 144 that protrudes from the side surface B. Thus, the gas-refrigerant supply pipe 144 does not interfere with the connection work of connecting the liquid-refrigerant supply pipe 143, and the spanner 1000 can be moved and engaged with to the liquid-pipe joint 151a at an appropriate angle and the liquid-pipe flare nut 152a can thus be tightened by the spanner 1000. Therefore, the spanner 1000 is not engaged with the liquid-pipe joint 151a at an inappropriate angle. It is therefore possible to prevent deformation

of the liquid-pipe joint 151a, thereby preventing damage to the brazed portion 154 and also occurrence of a refrigerant leak.

**[0052]** Regarding Embodiment 1, although it is described above that the first refrigerant supply pipe is the liquid-refrigerant supply pipe 143, and the second refrigerant supply pipe is the gas-refrigerant supply pipe 144, it is not limiting, and the relationship between these components may be reversed. That is, the first refrigerant supply pipe may be the gas-refrigerant supply pipe 144, and the second refrigerant supply pipe may be the liquid-refrigerant supply pipe 143. In either case, in the case where the first refrigerant supply pipe is provided above the second refrigerant supply pipe, the length L1 of the first refrigerant supply pipe is set longer than the length L2 of the second refrigerant supply pipe. As a result, the workability at the time of connecting the first refrigerant supply pipe can be improved.

**[0053]** In the modification of Embodiment 1 as illustrated in Figs. 4 and 5, the liquid-refrigerant supply pipe 143 includes the first pipe 161a and the liquid-pipe joint 151a, which is a first joint. The liquid-pipe joint 151a includes the first portion 155, the second portion 156, and the third portion 153. The first portion 155 of the first joint is provided at the distal end of the first pipe 161a. The second portion 156 is provided at one of the ends of the first portion 155 that is closer to the indoor unit 52a, and is connected to the indoor heat exchanger 5a of the indoor unit 52a. The third portion 153 is provided at one of the ends of the first portion 155 that is closer to the relay unit 53, and is fixed to the first pipe 161a by the brazed portion 154. The first portion 155, the second portion 156, and the third portion 153 are molded and formed integrally with each other. Alternatively, at least one of the first portion 155, the second portion 156, and the third portion 153 may be formed independently of the others, and then jointed to the others. Since the spanner 1000 is located on the first portion 155, the spanner 1000 is not located on the third portion 153. Since the third portion 153 is located between the first portion 155 and the brazed portion 154, in the connection work, the spanner 1000 is located apart from the brazed portion 154 by a longer distance. Thus, even if the first portion 155 of the liquid-pipe joint 151a is deformed, this deformation does not easily affect the brazed portion 154. It is therefore possible to prevent formation of a crack in the brazed portion 154, thus preventing occurrence of a leak of the refrigerant.

**[0054]** Similarly, the gas-pipe joint 151b, which is the second joint, may be formed to have the first portion 155, the second portion 156, and the third portion 153. In this case, the third portion 153 is fixed to the second pipe 161b by the brazed portion 154. Therefore, since the third portion 153 is located between the first portion 155 and the brazed portion 154, in the connection work, the spanner 1000 is located apart from the brazed portion 154 by a longer distance. Thus, even if the first portion 155 of the gas-pipe joint 151b is deformed, this deformation

does not easily affect the brazed portion 154. Therefore, it is possible to prevent formation of a crack in the brazed portion 154, thus preventing occurrence of a leak of the refrigerant.

#### Reference Signs List

**[0055]** 1: compressor, 2: outdoor heat exchanger, 3: four-way valve, 4: accumulator, 5a: indoor heat exchanger, 5b: indoor heat exchanger, 6a: indoor expansion device, 6b: indoor expansion device, 7a: check valve, 7b: check valve, 7c: check valve, 7d: check valve, 8: gas-liquid separator, 9: on-off valve, 9a: first on-off valve, 9b: first on-off valve, 10: on-off valve, 10a: second on-off valve, 10b: second on-off valve, 11: first expansion device, 12: second expansion device, 13: first heat exchanger, 14: second heat exchanger, 15: check valve, 15a: check valve, 15b: check valve, 16: check valve, 16a: check valve, 16b: check valve, 31: first pressure sensor, 32: second pressure sensor, 33a: first temperature sensor, 33b: first temperature sensor, 34a: second temperature sensor, 34b: second temperature sensor, 51: outdoor unit, 52: indoor unit, 52a: indoor unit, 52b: indoor unit, 53: relay unit, 53R: relay unit, 54: refrigerant flow control unit, 55: relay-unit trifurcate portion, 100: air-conditioning apparatus, 101: third liquid pipe, 102: third gas pipe, 103: first gas pipe, 104: first liquid pipe, 105: second liquid pipe, 105R: second liquid pipe, 105a: second liquid pipe, 105b: second liquid pipe, 106: second gas pipe, 106a: second gas pipe, 106b: second gas pipe, 110: first bypass pipe, 111: first relay-unit liquid pipe, 112: first relay-unit gas pipe, 113: second bypass pipe, 130: connection pipe, 131: connection pipe, 132: connection pipe, 133: connection pipe, 141: second relay-unit gas pipe, 142: second relay-unit liquid pipe, 143: liquid-refrigerant supply pipe, 143R: liquid-refrigerant supply pipe, 144: gas-refrigerant supply pipe, 144R: gas-refrigerant supply pipe, 145: hanging lug, 151a: liquid-pipe joint, 151aR: liquid-pipe joint, 151b: gas-pipe joint, 151bR: gas-pipe joint, 152a: liquid-pipe flare nut, 152aR: liquid-pipe flare nut, 152b: gas-pipe flare nut, 152bR: gas-pipe flare nut, 153: third portion, 154: brazed portion, 154R: brazed portion, 155: first portion, 155R: first portion, 156: second portion, 156R: second portion, 161a: first pipe, 161aR: first pipe, 161b: second pipe, 161bR: second pipe, 201: outdoor-side control unit, 202a: indoor-side control unit, 202b: indoor-side control unit, 203: relay-unit control unit, 1000: spanner, A: side surface B: side face, D: distance, Dth: first threshold, P: arrow, Pd: pressure, Ps: pressure, W: width, Wth: second threshold, a: connection point, b: connection point, c: connection point, d: connection point, e: connection point, f: connection point, g: connection point, h: connection point

#### Claims

1. An air-conditioning apparatus comprising:

an outdoor unit (51) including an outdoor heat exchanger (2);

an indoor unit (52) including an indoor heat exchanger (5a, 5b); and

a relay unit (53) provided between the outdoor unit (51) and the indoor unit (52), and including one or more first refrigerant supply pipes (143) and one or more second refrigerant supply pipes (144) that are connected to the indoor heat exchanger (5a, 5b) of the indoor unit (52),

wherein the one or more first refrigerant supply pipes (143) and the one or more second refrigerant supply pipes (144) protrude from a side surface (B) of the relay unit (53),

the one or more first refrigerant supply pipes (143) are each provided above an associated one of the one or more second refrigerant supply pipes (144),

a length (L1) of part of the one or more first refrigerant supply pipes (143) that protrudes from the side surface (B) is greater than a length (L2) of part of the one or more second refrigerant supply pipes (144) that protrudes from the side surface (B),

the one or more first refrigerant supply pipes (143) each include: a first pipe (161a) fixed to the side surface (B) of the relay unit (53); and a first joint (151a) located at a distal end of the first pipe (161a),

the first joint (151a) has: a first portion (155) located at the distal end of the first pipe (161a); a second portion (156) that is located at one of ends of the first portion (155) that is closer to the indoor unit (52), the second portion (156) being connected to the indoor heat exchanger (5a, 5b) of the indoor unit (52); a third portion (153) that is formed in the shape of a circular tube and located at the other end of the first portion (155), the other end of the first portion (155) being closer to the relay unit (53); and a brazed portion (154) located between the third portion (153) and the first pipe (161a) of the first refrigerant supply pipe (143), the third portion (153) being brazed to the first pipe (161a) of the first refrigerant supply pipe (143), and

a distance (L2 + D) from the side surface (B) to the one of the ends of the first portion (155) is longer than a distance (L2) from the side surface (B) to a distal end of the second refrigerant supply pipe (144).

2. The air-conditioning apparatus of claim 1, wherein

the number of the one or more first refrigerant supply pipes (143) is two or more, and the number of the one or more second refrigerant supply pipes (144) is two or more, any adjacent two of the one or more first refrig-

erant supply pipes (143) are provided apart from each other, and any adjacent two of the one or more second refrigerant supply pipes (144) are provided apart from each other.

3. The air-conditioning apparatus of claim 1 or 2, wherein

the one or more second refrigerant supply pipes (144) each include: a second pipe (161b) fixed to the side surface (B) of the relay unit (53); and a second joint (151b) located at a distal end of the second pipe (161b),  
 the second joint (151b) includes a first portion (155), a second portion (156), a third portion (153), and a brazed portion (154),  
 the first portion (155) of the second joint (151b) is located at the distal end of the second pipe (161b),  
 the second portion (156) of the second joint (151b) is located at one of ends of the first portion (155) of the second joint (151b) that is closer to the indoor unit (52), and is connected to the indoor heat exchanger (5a, 5b) of the indoor unit (52), and  
 the third portion (153) of the second joint (151b) is formed in the shape of a circular tube, located at the other end of the first portion (155) of the second joint (151b), and fixed to the second pipe (161b) of an associated one of the one or more second refrigerant supply pipes (144) by the brazed portion (154) of the second joint (151b), the other end of the first portion (155) being closer to the relay unit (53).

4. The air-conditioning apparatus of any one of claims 1 to 3, wherein

the one or more first refrigerant supply pipes (143) are each a liquid refrigerant supply pipe through which liquid refrigerant flows, and the one or more second refrigerant supply pipes (144) are each a gas refrigerant supply pipe through which gas refrigerant flows.

## Patentansprüche

1. Klimatisierungsvorrichtung, die aufweist:

eine Außeneinheit (51), die einen Außenwärmetauscher (2) umfasst;  
 eine Inneneinheit (52), die einen Innenwärmetauscher (5a, 5b) umfasst; und  
 eine Relaiseinheit (53), die zwischen der Außeneinheit (51) und der Inneneinheit (52) vorgesehen ist und die ein oder mehrere erste Kühl-

mittelzuführrohre (143) und ein oder mehrere zweite Kühlmittelzuführrohre (144) umfasst, die mit dem Innenwärmetauscher (5a, 5b) der Inneneinheit (52) verbunden sind,

wobei das eine oder die mehreren ersten Kühlmittelzuführrohre (143) und das eine oder die mehreren zweiten Kühlmittelzuführrohre (144) aus einer Seitenfläche (B) der Relaiseinheit (53) vorstehen,

das eine oder die mehreren ersten Kühlmittelzuführrohre (143) jeweils oberhalb eines verknüpften des einen oder der mehreren zweiten Kühlmittelzuführrohre (144) vorgesehen sind, eine Länge (L1) eines Teils des einen oder der mehreren ersten Kühlmittelzuführrohre (143), die aus der Seitenfläche (B) vorstehen, größer als eine Länge (L2) eines Teils des einen oder der mehreren zweiten Kühlmittelzuführrohre (144) ist, die aus der Seitenfläche (B) vorstehen, das eine oder die mehreren ersten Kühlmittelzuführrohre (143) jeweils umfassen: ein erstes Rohr (161a), das an der Seitenfläche (B) der Relaiseinheit (53) fixiert ist; und ein erstes Verbindungsstück (151a), das bei einem distalen Ende des ersten Rohrs (161a) lokalisiert ist, das erste Verbindungsstück (151a) aufweist: einen ersten Abschnitt (155), der bei dem distalen Ende des ersten Rohrs (161a) lokalisiert ist; einen zweiten Abschnitt (156), der bei einem der Enden des ersten Abschnitts (155) lokalisiert ist, das näher zur Inneneinheit (52) ist, wobei der zweite Abschnitt (156) mit dem Innenwärmetauscher (5a, 5b) der Inneneinheit (52) verbunden ist; einen dritten Abschnitt (153), der in der Form eines kreisförmigen Rohrs ausgebildet ist und der bei dem anderen Ende des ersten Abschnitts (155) lokalisiert ist, wobei das andere Ende des ersten Abschnitts (155) näher zur Relaiseinheit (53) ist; und einen hartgelöteten Abschnitt (154), der zwischen dem dritten Abschnitt (153) und dem ersten Rohr (161a) des ersten Kühlmittelzuführrohrs (143) lokalisiert ist, wobei der dritte Abschnitt (153) mit dem ersten Rohr (161a) des ersten Kühlmittelzuführrohrs (143) hartgelötet ist, und eine Entfernung (L2 + D) von der Seitenfläche (B) zu dem einen der Enden des ersten Abschnitts (155) länger als eine Entfernung (L2) von der Seitenfläche (B) zu einem distalen Ende des zweiten Kühlmittelzuführrohrs (144) ist.

2. Klimatisierungsvorrichtung nach Anspruch 1, wobei

die Anzahl des einen oder der mehreren ersten Kühlmittelzuführrohre (143) zwei oder mehr ist, und die Anzahl des einen oder der mehreren zweiten Kühlmittelzuführrohre (144) zwei oder mehr ist,

irgendwelche zwei benachbarten des einen oder der mehreren ersten Kühlmittelzuführrohre (143) beabstandet voneinander vorgesehen sind, und

irgendwelche zwei benachbarten des einen oder der mehreren zweiten Kühlmittelzuführrohre (144) beabstandet voneinander vorgesehen sind.

3. Klimatisierungsvorrichtung nach Anspruch 1 oder 2, wobei

das eine oder die mehreren zweiten Kühlmittelzuführrohre (144) jeweils umfassen: ein zweites Rohr (161b), das an der Seitenfläche (B) der Relaiseinheit (53) fixiert ist; und ein zweites Verbindungsstück (151b), das bei einem distalen Ende des zweiten Rohrs (161b) lokalisiert ist, das zweite Verbindungsstück (151b) einen ersten Abschnitt (155), einen zweiten Abschnitt (156), einen dritten Abschnitt (153) und einen hartgelöteten Abschnitt (154) umfasst, der erste Abschnitt (155) des zweiten Verbindungsstücks (151b) bei dem distalen Ende des zweiten Rohrs (161b) lokalisiert ist, der zweite Abschnitt (156) des zweiten Verbindungsstücks (151b) bei einem der Enden des ersten Abschnitts (155) des zweiten Verbindungsstücks (151b) lokalisiert ist, das näher zur Inneneinheit (52) ist, und mit dem Innenwärmetauscher (5a, 5b) der Inneneinheit (52) verbunden ist, und der dritte Abschnitt (153) des zweiten Verbindungsstücks (151b) in der Form eines kreisförmigen Rohrs ausgebildet ist, bei dem anderen Ende des ersten Abschnitts (155) des zweiten Verbindungsstücks (151b) lokalisiert ist und an dem zweiten Rohr (161b) eines verknüpften des einen oder der mehreren zweiten Kühlmittelzuführrohre (144) durch den hartgelöteten Abschnitt (154) des zweiten Verbindungsstücks (151b) fixiert ist, wobei das andere Ende des ersten Abschnitts (155) näher zur Relaiseinheit (53) ist.

4. Klimatisierungsvorrichtung nach einem der Ansprüche 1 bis 3, wobei

das eine oder die mehreren ersten Kühlmittelzuführrohre (143) jeweils ein Flüssigkühlmittelzuführrohr sind, durch welches flüssiges Kühlmittel fließt, und

das eine oder die mehreren zweiten Kühlmittelzuführrohre (144) jeweils ein Gaskühlmittelzuführrohr sind, durch welches Gaskühlmittel strömt.

## Revendications

1. Appareil de climatisation comprenant :

une unité d'extérieur (51) incluant un échangeur de chaleur d'extérieur (2) ;

une unité d'intérieur (52) incluant un échangeur de chaleur d'intérieur (5a, 5b) ; et

une unité de relais (53) fournie entre l'unité d'extérieur (51) et l'unité d'intérieur (52), et incluant un ou plusieurs premiers tuyaux d'alimentation en fluide frigorigène (143) et un ou plusieurs deuxièmes tuyaux d'alimentation en fluide frigorigène (144) qui sont raccordés à l'échangeur de chaleur d'intérieur (5a, 5b) de l'unité d'intérieur (52),

les un ou plusieurs premiers tuyaux d'alimentation en fluide frigorigène (143) et les un ou plusieurs deuxièmes tuyaux d'alimentation en fluide frigorigène (144) faisant saillie à partir d'une surface latérale (B) de l'unité de relais (53),

les un ou plusieurs tuyaux d'alimentation en fluide frigorigène (143) sont chacun fournis au-dessus d'un tuyau associé parmi les un ou plusieurs deuxièmes tuyaux d'alimentation en fluide frigorigène (144),

une longueur (L1) d'une partie des un ou plusieurs premiers tuyaux d'alimentation en fluide frigorigène (143) qui fait saillie à partir de la surface latérale (B) est supérieure à une longueur (L2) d'une partie des un ou plusieurs deuxièmes tuyaux d'alimentation en fluide frigorigène (144) qui fait saillie à partir de la surface latérale (B),

les un ou plusieurs premiers tuyaux d'alimentation en fluide frigorigène (143) incluent chacun : un premier tuyau (161a) fixé à la surface latérale (B) de l'unité de relais (53) ; et un premier joint (151a) situé au niveau d'une extrémité distale du premier tuyau (161a),

le premier joint (151a) a : une première portion (155) située au niveau de l'extrémité distale du premier tuyau (161a) ; une deuxième portion (156) qui est située au niveau de l'une des extrémités de la première portion (155) qui est plus proche de l'unité d'intérieur (52), la deuxième portion (156) étant raccordée à l'échangeur de chaleur d'intérieur (5a, 5b) de l'unité d'intérieur (52) ; une troisième portion (153) qui est formée sous la forme d'un tube circulaire et située au niveau de l'autre extrémité de la première portion (155), l'autre extrémité de la première portion (155) étant plus proche de l'unité de relais (53) ; et une portion brasée (154) située entre la troisième portion (153) et le premier tuyau (161a) du premier tuyau d'alimentation en fluide frigorigène (143), la troisième portion (153) étant brasée au premier tuyau (161a) du premier tuyau d'alimentation en fluide frigorigène (143),

- et  
 une distance (L2 + D) de la surface latérale (B) à l'une des extrémités de la première portion (155) est plus longue qu'une distance (L2) de la surface latérale (B) à une extrémité distale du deuxième tuyau d'alimentation en fluide frigorigène (144). 5
2. Appareil de climatisation selon la revendication 1, dans lequel 10
- le nombre des un ou plusieurs premiers tuyaux d'alimentation en fluide frigorigène (143) est de deux ou plus, et le nombre des un ou plusieurs tuyaux d'alimentation en fluide frigorigène (144) est de deux ou plus, 15
- n'importe lequel des un ou plusieurs premiers tuyaux d'alimentation en fluide frigorigène (143) sont fournis à distance l'un de l'autre, et 20
- n'importe lequel des un ou plusieurs deuxièmes tuyaux d'alimentation en fluide frigorigène (144) sont fournis à distance l'un de l'autre.
3. Appareil de climatisation selon la revendication 1 ou la revendication 2, dans lequel 25
- les un ou plusieurs deuxièmes tuyaux d'alimentation en fluide frigorigène (144) incluent chacun : un deuxième tuyau (161b) fixé à la surface latérale (B) de l'unité de relais (53) ; et un deuxième joint (151b) situé au niveau d'une extrémité distale du deuxième tuyau (161b), 30
- le deuxième joint (151b) inclut une première portion (155), une deuxième portion (156), une troisième portion (153) et une portion brasée (154), 35
- la première portion (155) du deuxième joint (151b) est située au niveau de l'extrémité distale du deuxième tuyau (161b),
- la deuxième portion (156) du deuxième joint (151b) est située au niveau de l'une des extrémités de la première portion (155) du deuxième joint (151b) qui est plus proche de l'unité d'intérieur (52), et est raccordée à l'échangeur de chaleur d'intérieur (5a, 5b) de l'unité d'intérieur (52), 40
- et 45
- la troisième portion (153) du deuxième joint (151b) est formée sous la forme d'un tube circulaire, situé au niveau de l'autre extrémité de la première portion (155) du deuxième joint (151b), et fixé au deuxième tuyau (161b) d'un tuyau associé parmi les un ou plusieurs deuxièmes tuyaux d'alimentation en fluide frigorigène (144) par la portion brasée (154) du deuxième joint (151b), l'autre extrémité de la première portion (155) étant plus proche de l'unité de relais (53). 50 55
4. Appareil de climatisation selon n'importe laquelle

des revendications 1 à 3, dans lequel

les un ou plusieurs premiers tuyaux d'alimentation en fluide frigorigène (143) sont chacun un tuyau d'alimentation en fluide frigorigène liquide à travers lequel s'écoule un fluide frigorigène liquide, et

les un ou plusieurs deuxièmes tuyaux d'alimentation en fluide frigorigène (144) sont chacun un tuyau d'alimentation en fluide frigorigène liquide à travers lequel s'écoule un fluide frigorigène liquide.



FIG. 2

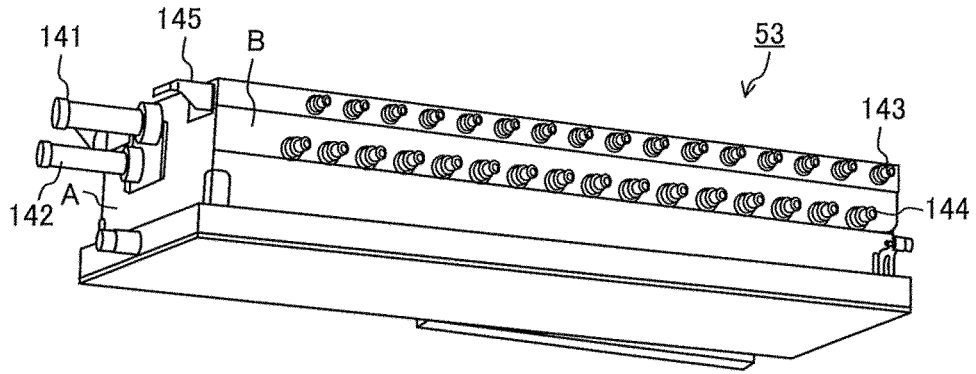

FIG. 3

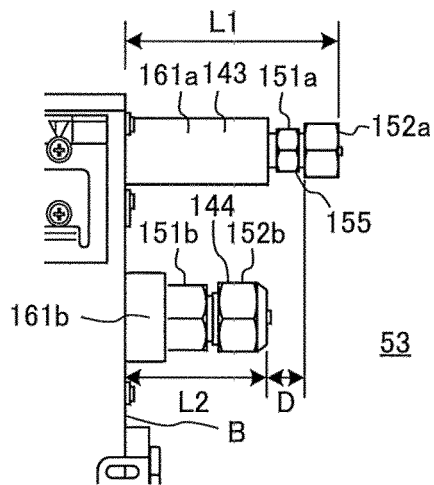



FIG. 6

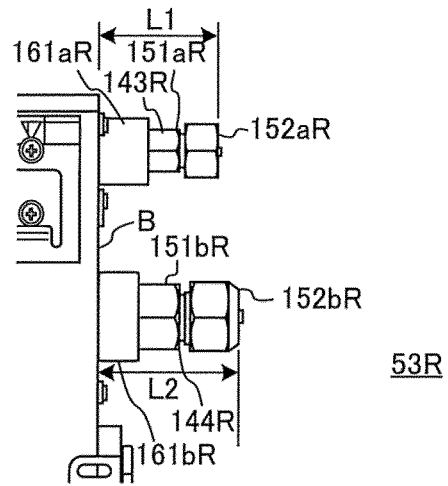

FIG. 7

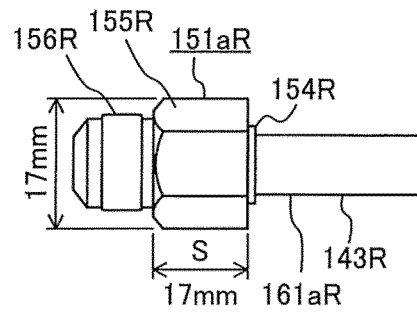

FIG. 8

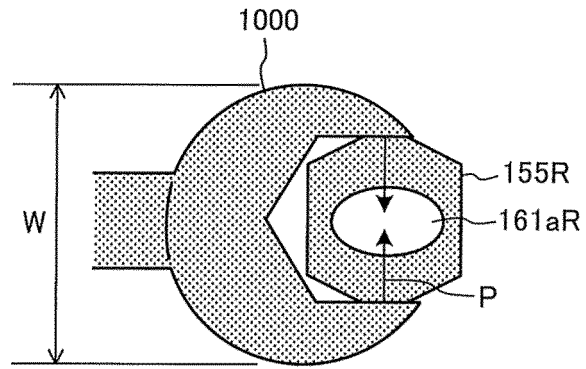
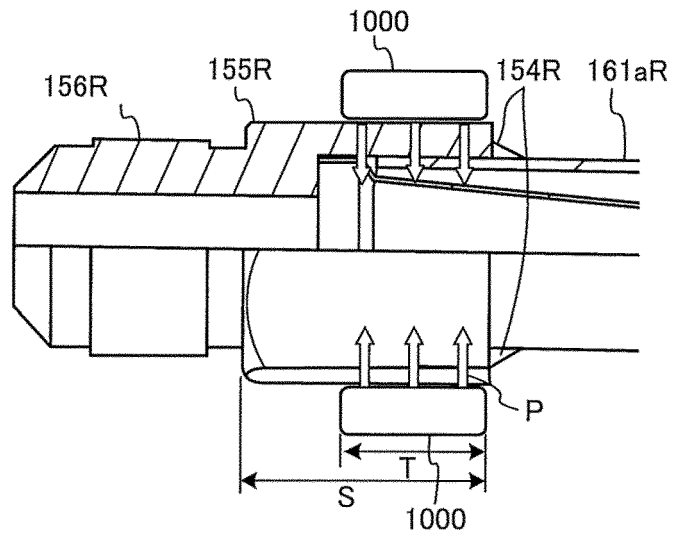

FIG. 9



**REFERENCES CITED IN THE DESCRIPTION**

*This list of references cited by the applicant is for the reader's convenience only. It does not form part of the European patent document. Even though great care has been taken in compiling the references, errors or omissions cannot be excluded and the EPO disclaims all liability in this regard.*

**Patent documents cited in the description**

- JP 3235189 B [0008]
- JP 2005326090 A [0008]
- JP 3132198 B [0008]