



EUROPEAN PATENT APPLICATION

Application number : **94203173.3**

Int. Cl.⁶ : **E04B 1/76, E04F 13/06**

Date of filing : **01.11.94**

Priority : **03.11.93 NL 9301892**

Inventor : **van Strien, Johannes Adrianus Cornelis**
Maasdijk 12b
NL-4284 VA Rijswijk (NL)

Date of publication of application :
03.05.95 Bulletin 95/18

Designated Contracting States :
AT BE CH DE FR LI LU NL

Representative : **Prins, Hendrik Willem**
Octrooibureau Arnold & Siedsma
Sweelinckplein, 1
NL-2517 GK The Hague (NL)

Applicant : **van Strien, Johannes Adrianus Cornelis**
Maasdijk 12b
NL-4284 VA Rijswijk (NL)

Wall insulation and a plastic profile system therefor.

The invention relates to a wall insulation (1) for insulating a wall (2) with a plastic profile system (3) comprising insulating plate-like material (8), which profile system comprises a plastic socle profile (4) for fixing to the wall, and a plastic edge profile (5) which is provided with a closing edge for enclosing the plate material and with a supporting edge for receiving coating material to be arranged on the plate material, wherein the socle profile and the edge profile are provided with co-acting coupling means, and to the plastic profile system.

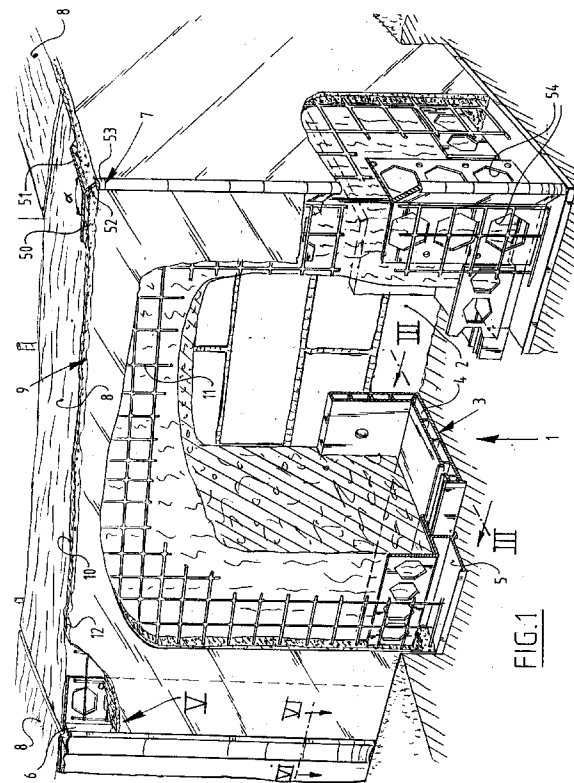

The present invention relates to a wall insulation and to a plastic profile system therefor. The present invention relates more in particular to a wall insulation wherein insulating plate-like materials such as of polystyrene and mineral wool are arranged on the wall with this plastic profile system. In the case of a building this can take place on the inside and on the outside.

Known wall insulations for this purpose have the drawback that when diverse coating materials are used for the visual layer, different profiles must be used in each case, while such profiles corrode immediately or after a period of time due to the alkaline conditions present or formed in the coating material. After a time the wall insulation will therefore no longer meet the demands made thereof.

The present invention has for its object to provide a wall insulation and a profile system therefor which substantially does not display the above stated drawbacks.

This is achieved according to the invention with a wall insulation according to the invention for insulating a wall with a plastic profile system comprising insulating plate-like material, which profile system comprises:

a plastic socle profile for fixing to the wall, and a plastic edge profile which is provided with a closing edge for enclosing the plate material and with a supporting edge for receiving coating material to be arranged on the plate material, wherein the socle profile and the edge profile are provided with co-acting coupling means.

By making use of socle profiles and edge profiles for mutual coupling the wall insulation according to the invention can be continuously adapted to the thicker or thinner coating material for use, while corrosion problems substantially do not occur.

According to an embodiment of the coupling means according to the invention the socle profile is provided with a free leg standing away from the wall having at least one hooking edge comprised by the coupling means and behind which hooks an edging profile edge. For an optimum coupling between the socle profile and the edge profile it is herein recommended that the socle profile is provided with two hooking edges and the profile with two co-acting socle profile hooking edges.

In preference a first socle profile hooking edge is formed in the surface of the free leg. It is thus possible to form the socle profile hooking edge in the surface directed toward the insulating plate-like material or toward the usually bottom surface remote therefrom. An optimum choice can be made in accordance with the application.

A second socle profile hooking edge is preferably formed on the free end of the socle profile leg.

The robustness of the edge profile is increased while the intended functions are retained if in prefer-

ence the closing edge stands on a base which connects onto the free leg. For optimum fixing of the coating material and for optimum support thereof on the supporting edge it is further recommended that the supporting edge connects onto the base with the forming of a channel open to the side. An optimum construction is obtained if in further preference the base is provided with the first edge profile hooking edge and the supporting edge with the second edge profile hooking edge.

In order to bridge vertical joints in particular, such as expansion joints between adjoining plates of material, in a manner which in particular is aesthetically responsible, while the coating material can be arranged optimally, it is further recommended that a joint between mutually adjoining plates of material is bridged by an expansion profile with two limbs which are each fixed to a plate of material and have a connecting edge for coating material and which are mutually connected by a membrane.

In order to make it possible after arranging of the coating material to remove from the membrane undesired coating material which has fallen thereon, it is further recommended that the membrane is provided with a removable protective strip.

The transition between two plate-like materials standing in particular at an angle can be spanned in optimal manner while the coating material can be arranged quickly and simply if in further preference plates of material standing at an angle are connected by a corner profile having legs standing at an angle fixed to the plates or the wall and a corner edge extending through the coating material. The angle is preferably smaller than 90° so that angles larger than and beyond 90° can be spanned simply by bending the legs outward.

Finally, the present invention relates to the plastic profile system per se which comprises a plastic socle profile, a plastic edge profile, a plastic expansion profile and a plastic corner profile, the construction of which is described above.

Mentioned and other features of the wall insulation and the associated plastic profile system will be further elucidated hereinbelow on the basis of a number of embodiments given only by way of example, while reference is made to the annexed drawings.

In the drawings:

figure 1 shows a perspective partly broken away view of a wall insulation according to the invention;

figure 2 shows a section illustrating the coupling of a socle profile and an edge profile;

figure 3 shows a section corresponding with figure 2 along the line III-III in figure 1;

figure 4 shows a section corresponding with figure 3 of another embodiment;

figure 5 shows detail V of figure 1 on a larger scale;

figure 6 shows a section along the line VI-VI in figure 1; and

figure 7 shows a section corresponding with figure 6 with an expansion profile bridging plate materials standing at an angle.

Figures 1-3 show a wall insulation 1 according to the invention for an outside wall 2 of a building. The wall insulation 1 comprises a plastic profile system 3 comprising a socle profile 4 with an edge profile 5 coupled thereto by hooks, in addition to an expansion profile 6 and a corner profile 7.

With this profile system plate-like insulation material such as plates 8 of flame-extinguishing, expanded polystyrene or mineral wool is fixed to the wall 2. These plates 8 are provided with a coating layer 9 which consists of a dense earth mortar having embedded therein a pressure-distributing, mesh-like layer 11 and a visual mortar 12 of relatively open structure. As shown in figure 1, the wall insulation can be arranged below ground level but can also extend only above ground level in the case for instance a ground floor does not have to be insulated.

Figure 2 shows in more detail the coupling between socle profile 4 and edge profile 5. Socle profile 4 is arranged in the wall 2 with a screw 13 and rests in the ground 14. Socle profile 4 comprises a leg 15, which is fixed with screw 13 to the wall 2, and a free leg 16. The latter is provided with the coupling means 17. These coupling means 17 comprise a first hooking edge 18 which is formed in the surface 19 of the free leg 16 and a second hooking edge 20 formed on the free end 21 of the leg 16. Herein formed is a channel 22 open to the top in which the edge profile 5 will engage with corresponding coupling means 17.

The edge profile 5 comprises a closing edge 23, with which the plate material 8 is enclosed, and a supporting edge 24 for receiving coating material, both earth mortar and visual mortar and the mesh layer 11. The supporting edge 24 ends in a guide edge 25 so that the coating material 12 can be spread smoothly.

The closing edge 23 stands on a base 26 which connects onto the free leg 16 of socle profile 4. Supporting edge 24 is connected via a partition 27 to the base 26 and therein forms a channel 28 open to the side which is filled with coating material 10, 12 and the mesh layer 11, whereby a very adequate support and protection is obtained.

Base 26 is further provided with a hooking edge 29 which co-acts with hooking edge 18 of the socle profile and further a hooking edge 30 which co-acts with hooking edge 20 of the socle profile. The hooking edge 29 herein lies in the channel 22. The coupling between socle profile 4 and edge profile 5 is effected by hooking on edge profile 5 from below as according to arrow 31.

In the variant shown in figure 4 the edge profile 5 is hooked on by hooking from below in the direction of arrow 32.

The free leg 33 is now provided on the bottom surface 34 with the channel 35 with hooking edge 36 and the hooking edge 37 is located on the free end 21. Co-acting herewith are the hooking edges 38 and 39 respectively connected to supporting edge 40 respectively base 41.

Figure 5 shows the expansion profile 6 according to the invention which is located at the position of an expansion joint 42. The expansion profile 6 comprises two limbs 43 and 44 each fixed to the plate material 8 with pins 45 and having edges 46 standing therefrom, the thickness of which is substantially the same as the thickness of the total coating layer. The edges 46 transpose into a bent edge portion 47. Edges 46 are further joined via a flexible membrane 48 which spans the actual expansion joint 42. Edge portions 47 form a guide during arranging of the coating material and fouling of membrane 48 with coating material is avoided by temporarily arranging thereon a protective strip 49 which can be removed afterward.

Figure 6 shows the expansion joint from the top.

Figure 7 shows the same expansion profile 6, now in a situation wherein the plates 8 of the insulating material stand at an angle and this angle is bridged by a further curving of the membrane 48.

Finally, figure 1 indicates the construction of the corner profile 7. This latter comprises legs 50 and 51 which stand at an angle α . A corner edge 52 protrudes away from the meeting point of the legs 50, 51, which edge extends through the coating material 10-12 and ends in a visual edge 53 which also serves as guide in arranging of the coating material.

Figure 1 further shows that the legs 50, 51 and the limbs 43, 44 are provided with holes 53, 54 to obtain an optimal anchoring thereof in the coating material.

As coating material can be used silicone-set thin mineral plasters, wherein finishing can be done with a heavy mineral top layer 12.

Claims

1. Wall insulation for insulating a wall with a plastic profile system comprising insulating plate-like material, which profile system comprises:
 - a plastic socle profile for fixing to the wall, and
 - a plastic edge profile which is provided with a closing edge for enclosing the plate material and with a supporting edge for receiving coating material to be arranged on the plate material, wherein the socle profile and the edge profile are provided with co-acting coupling means.
2. Wall insulation as claimed in claim 1, wherein the socle profile is provided with a free leg standing away from the wall having at least one hooking

edge comprised by the coupling means and behind which hooks an edging profile edge.

3. Wall insulation as claimed in claims 1 and 2, wherein the socle profile is provided with two hooking edges and the edge profile with two co-acting socle profile hooking edges. 5
4. Wall insulation as claimed in claim 2 or 3, wherein a first socle profile hooking edge is formed in the surface of the free leg. 10
5. Wall insulation as claimed in claims 2-4, wherein a second socle profile hooking edge is formed on the free end of the socle profile leg. 15
6. Wall insulation as claimed in claims 1-5, wherein the closing edge stands on a base which connects onto the free leg. 20
7. Wall insulation as claimed in claim 6, wherein the supporting edge connects onto the base with the forming of a channel open to the side.
8. Wall insulation as claimed in claim 6 or 7, wherein the base is provided with the first edge profile hooking edge and the supporting edge with the second edge profile hooking edge. 25
9. Wall insulation as claimed in claims 1-8, wherein a joint between mutually adjoining plates of material is bridged by an expansion profile with two limbs which are each fixed to a plate of material and have a connecting edge for coating material and which are mutually connected by a membrane. 30
35
10. Wall insulation as claimed in claim 9, wherein the membrane is provided with a removable protective strip. 40
11. Wall insulation as claimed in claims 1-10, wherein plates of material standing at an angle are connected by a corner profile having legs at an angle fixed to the plates or the wall and a corner edge extending through the coating material. 45
12. Wall insulation as claimed in claim 11, wherein the angle is smaller than 90°. 50
13. Plastic profile system, a socle profile and an edge profile, an expansion profile and a corner profile therefor as claimed in claims 1-12. 55

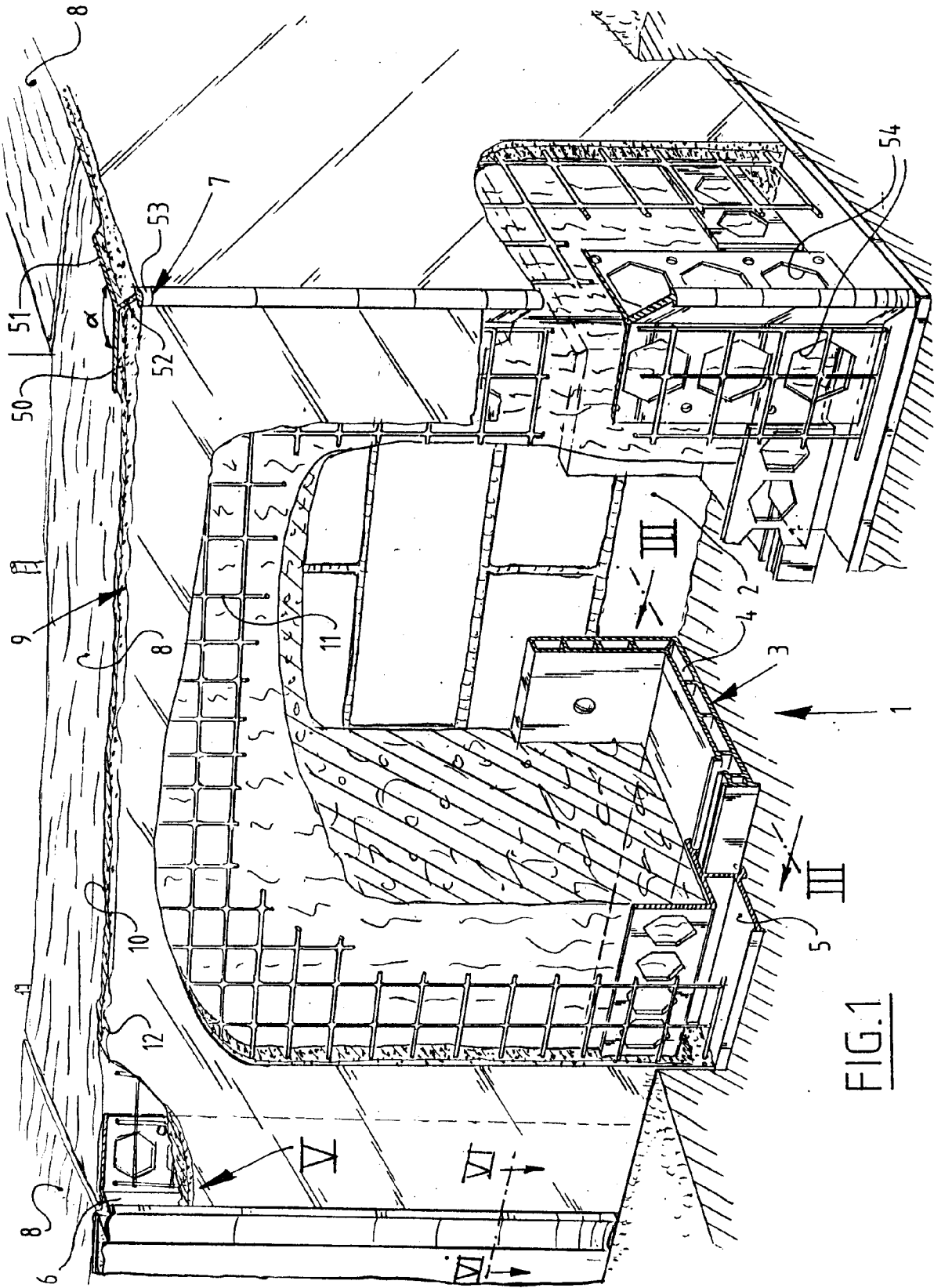

FIG.1

FIG.2

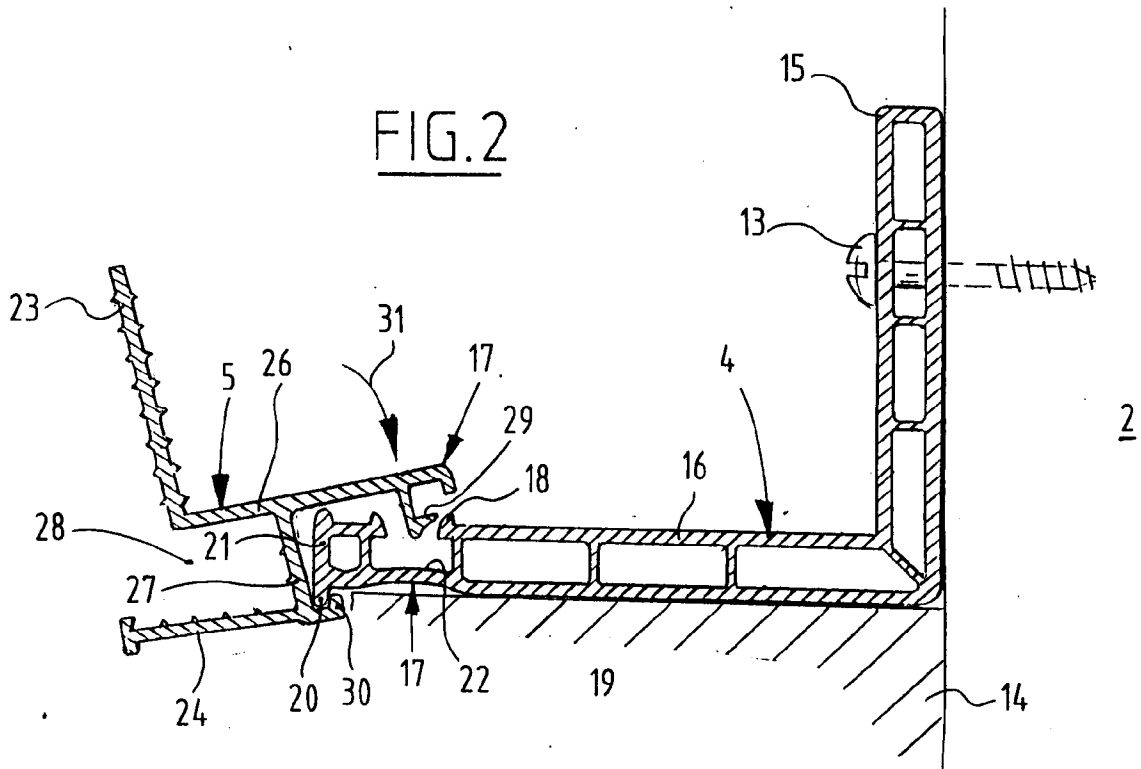
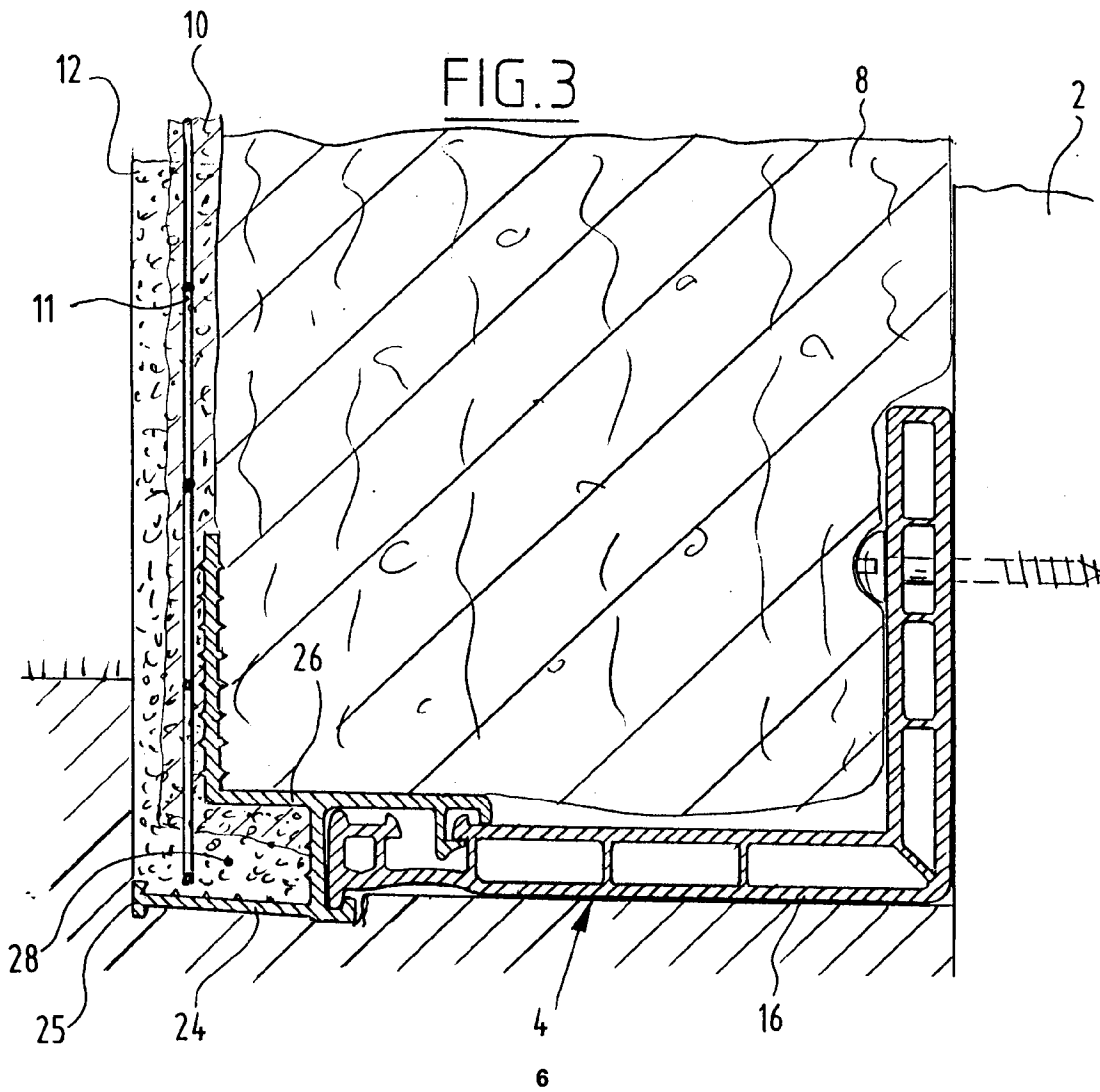

FIG.3





European Patent
Office

EUROPEAN SEARCH REPORT

Application Number
EP 94 20 3173

DOCUMENTS CONSIDERED TO BE RELEVANT			
Category	Citation of document with indication, where appropriate, of relevant passages	Relevant to claim	CLASSIFICATION OF THE APPLICATION (Int.Cl.6)
X Y	US-A-5 003 743 (BIFANO) * column 2, line 60 - column 6, line 46; figures 8-12 *	1,2 3,4,7	E04B1/76 E04F13/06
Y A	GB-A-2 241 261 (LEEDHAM-GREEN) * the whole document *	3,4,7 1,2	
A	DE-U-89 04 949 (CAPATECT DÄMMSYSTEME GMBH & CO. ENERGIETECHNIK KG) * page 6, paragraph 2 * * page 6, paragraph 4 - page 8, paragraph 1; figures *	1,2	
A	US-A-4 651 488 (NICHOLAS ET AL) * column 2, line 29 - column 3, line 35; figures *	9,10	
A	EP-A-0 514 855 (JANNUSCH) * the whole document *	11,12	
A	EP-A-0 468 163 (DUBIEL)		
			TECHNICAL FIELDS SEARCHED (Int.Cl.6)
			E04B E04F
The present search report has been drawn up for all claims			
Place of search THE HAGUE		Date of completion of the search 13 February 1995	Examiner Fordham, A
CATEGORY OF CITED DOCUMENTS		T : theory or principle underlying the invention E : earlier patent document, but published on, or after the filing date D : document cited in the application L : document cited for other reasons & : member of the same patent family, corresponding document	
X : particularly relevant if taken alone Y : particularly relevant if combined with another document of the same category A : technological background O : non-written disclosure P : intermediate document			

EPO FORM L501 03.92 (P04C01)