

J. C. HUNT & W. W. INGRAHAM.

Improvement in Grain-Scourer, Smutter, and Separator.

No. 130,804.

Patented Aug. 27, 1872.

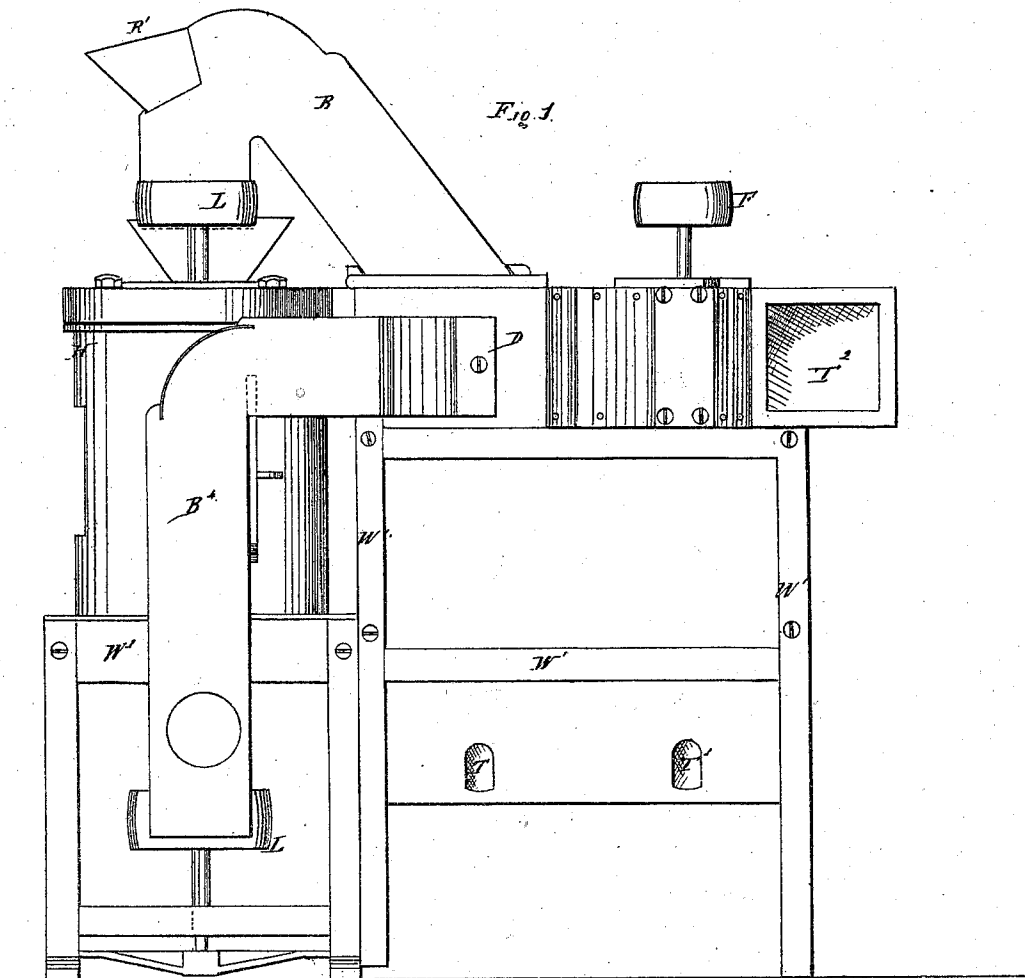

Witnesses:

F. F. Warner
A. F. Brunst.

Inventor:

John C. Hunt
W. W. Ingraham
per
Lewis L. Cochran
Atty.

J. C. HUNT & W. W. INGRAHAM.

Improvement in Grain-Scourer, Smutter, and Separator.

No. 130,804.

Patented Aug. 27, 1872.

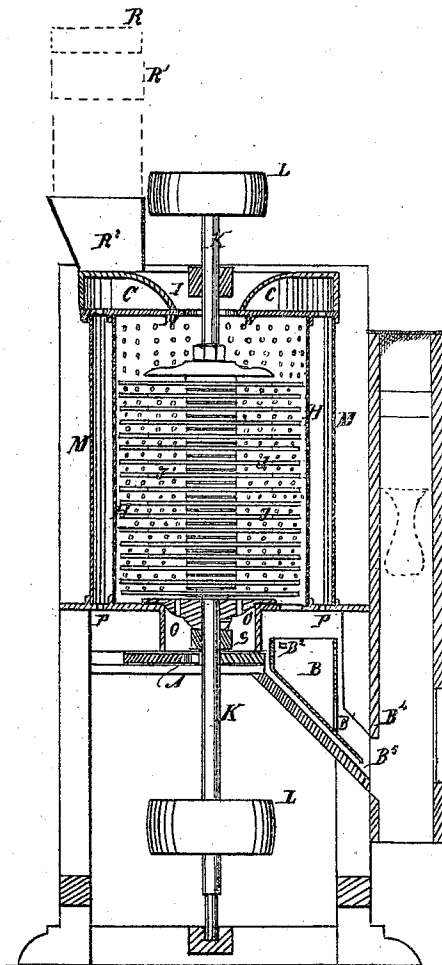
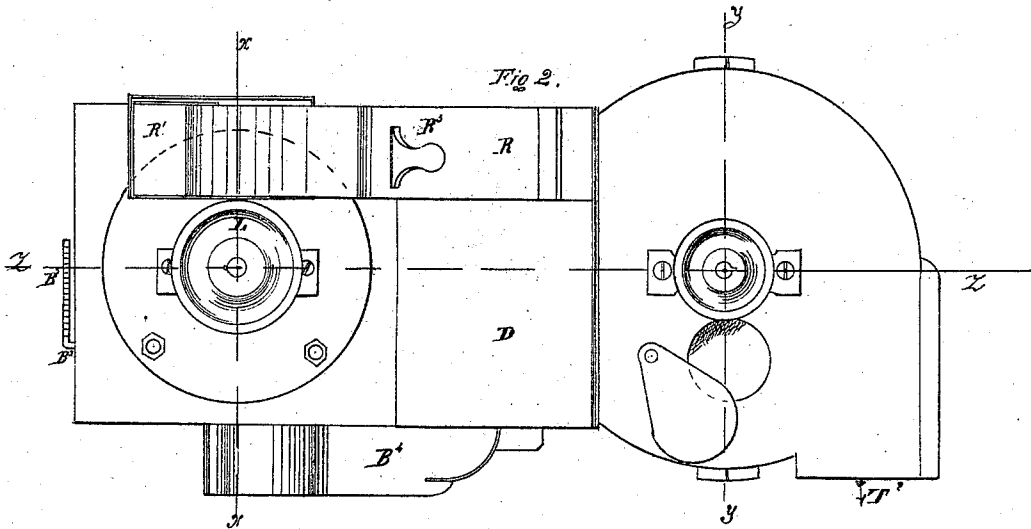

Witnesses:
F. F. Warner
H. F. Brown

Inventors:
John C. Hunt
Wm. W. Ingraham
per Lewis L. Babcock
att'y.

J. C. HUNT & W. W. INGRAHAM.

Improvement in Grain-Scourer, Smutter, and Separator.

No. 130,804.

Patented Aug. 27, 1872.

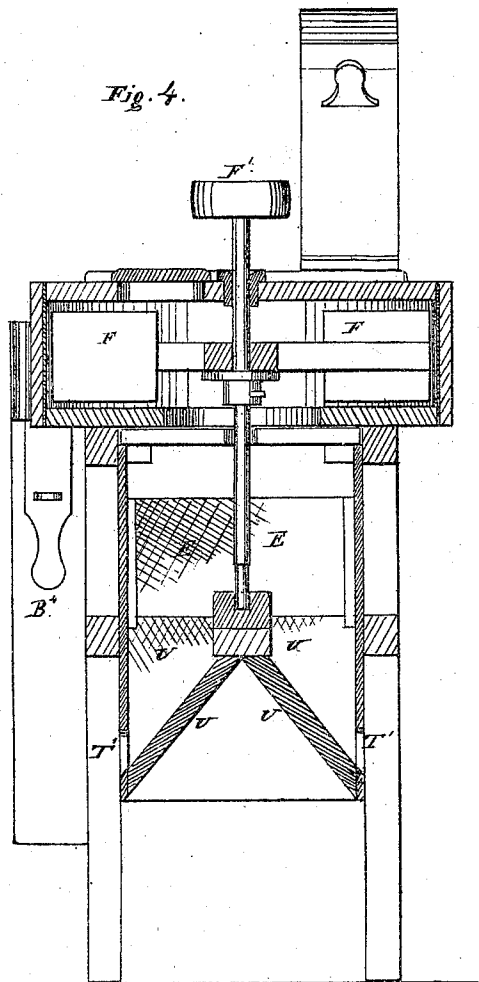

Witnesses:

F. F. Warner
H. F. Brant.

Inventors:

John C. Hunt
W. W. Ingraham
per
Lewis L. Coburn
Atty

J. C. HUNT & W. W. INGRAHAM.

Improvement in Grain-Scourer, Smutter, and Separator.

No. 130,804.

Patented Aug. 27, 1872.

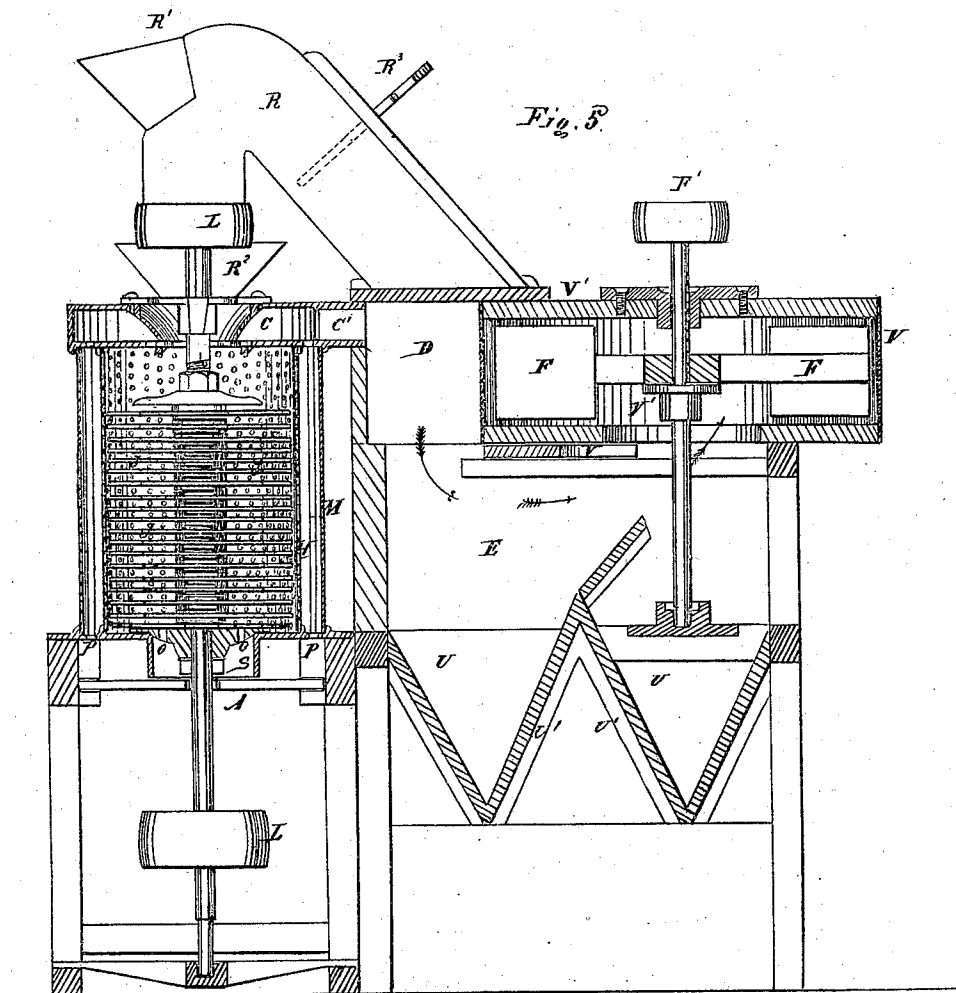

Witnesses:

F. F. Warner
H. F. Brown.

Inventors:

John C. Hunt
Wm. W. Ingraham
per
Lewis L. Coburn
att.

UNITED STATES PATENT OFFICE.

JOHN C. HUNT AND WILLIAM W. INGRAHAM, OF CHICAGO, ILLINOIS; SAID HUNT ASSIGNS HIS RIGHT TO SAID INGRAHAM.

IMPROVEMENT IN GRAIN SCOURERS, SMUTTERS, AND SEPARATORS.

Specification forming part of Letters Patent No. 130,804, dated August 27, 1872.

SPECIFICATION.

We, JOHN C. HUNT and WILLIAM W. INGRAHAM, of Chicago, in the county of Cook and State of Illinois, have invented a new and useful Improvement in Grain Smutters, Scourers, and Separators, of which the following is a specification, reference being had to the accompanying drawing.

Nature and Object of our Invention.

Our invention relates to that class of machines in which the grain is scoured by friction and the dust separated from the grain, as well as the light material, and the grain also separated into different grades, according to its weight, by a suction-blast drawn through the grain; and our invention consists in the devices, hereafter fully described, for regulating the flow of grain from the scouring-cylinder, and in the chambers and connecting-pipes at the top of the machine. The grain flows automatically from the scouring-cylinder by its weight opening the valve, and the valve may be regulated so as to hold a greater or less quantity of grain in the scouring-cylinder, and the light grain and small seeds that are carried over into the chamber E are divided into four grades, and the dust is blown out through the fan at T².

Description of the Drawing.

Figure 1, Plate 1, is a side elevation of our improved machine. Fig. 2, Plate 2, is a top or plan view of the same. Fig. 3 is a transverse vertical sectional view taken at the line *x x*, Fig. 2. Fig. 4, Plate 3, is a transverse sectional view taken at the line *y y*, Fig. 2; and Fig. 5, Plate 4, is a longitudinal central vertical sectional view taken at the line *z z*, Fig. 2.

General Description.

The same letters of reference are used to represent the corresponding parts in the different figures.

H represents the scouring-cylinder, into which the grain is admitted through the hopper I. J are beaters, attached to the shaft K, by which they are made to revolve to scour the grain in the cylinder H. The shaft K has bearings, as clearly shown in the drawing,

and is driven by a band running on either of the pulleys L. My invention does not relate to the scouring-cylinder or its beaters, therefore any well-known apparatus for holding and scouring the grain may be used providing that there are openings in the bottom of the cylinder for the admission of air, as hereafter described, and an opening for the escape of the grain. M is a case inclosing the scouring-cylinder H, forming an air-space between the two. O are openings for the admission of air into the bottom of the scouring-cylinder H. P are openings for the admission of air into the air-space between the cylinders H and M. The air is taken through the openings O from the chamber S; and A is a sliding-valve to regulate the admission of air into the chamber S. By opening or closing the valve A, by sliding it along, the quantity of air that is allowed to pass into the bottom of the cylinder H and through the grain, while being scoured, is regulated. B is a peculiarly-constructed, automatic, weighted valve that regulates the flow of the grain from the scouring-cylinder, and it may be so regulated by adjusting a weight that the grain will at all times be held in the scouring-cylinder up to any desired height. This valve is made in the form of a box, open at the top, and with an opening, B¹, near its bottom, as shown. It is hung rigidly on a shaft, B², extending across it on one side near its top, which shaft extends out through the case of the machine, and is bent so as to receive a weight, as at B³, which weight may be adjusted thereon to regulate the weight required in the box B to turn the shaft. If the weight is placed near the end of B³ it turns the shaft B², and swings the box B so that the extended bottom of the box swings up against the side of the spout B⁴, and closes the opening B⁵ so that no grain can flow from the cylinder H through said opening until the grain rises high enough in the said scouring-cylinder H so that the weight of the grain resting on the valve B shall be sufficient to raise the weight on B³, and thereby turn the box-valve and open the opening B⁵. If a less height of grain is desired in the scouring-cylinder H, so as to have it run through the machine with less scouring, the weight on B³ is adjusted so that a less weight of grain in the cylinder H will

open the valve B, as above described. C is a chamber at the top of the scouring-cylinder H, and beneath the hopper I, into which the dust scoured from the grain in the scouring-cylinder is drawn by the currents of air passing up through the scouring-cylinder and the air-space surrounding it. C' is a pipe leading from the chamber C to the chamber D. The grain is fed into the machine through one end of the bent pipe R, it being introduced at R¹, from whence it falls into the hopper R², and then through the hopper I into the scouring-cylinder; the other end of the bent pipe or spout R extends down and opens into the box D. R³ is a slide-valve, for opening and closing the tube R so as to regulate the draft of air that is drawn through the grain as it is being admitted into the machine, as hereinafter described. B⁴ is a tube or spout, through the lower end of which the scoured grain which flows from the smutting-cylinder H passes; and that also extends up and opens into the chamber D, as clearly shown in Figs. 1 and 2.

It will be observed that the gleanings taken from the grain through the tube R before it passes into the machine, and also the smut and dust taken from it while it is in the scouring-cylinder, as well as the light scoured grain and dust taken from it in the pipe B⁴, are all drawn into the chamber D; but the light scoured grain is brought into said chamber at the side opposite from where the gleanings and unscoured grain that are brought in the tube R enter the chamber. All this material passes down from the chamber D into the chamber E, and the heaviest of it will fall to the bottom of the chamber and escape at the openings T, while the lighter material will be carried further over and fall down and escape at the openings T¹, and the very lightest material, such as the smut and dust, will be drawn up into the fan and escape at T². U is a central double-inclined partition in the bottom of the box E; and U' is a similar transverse par-

tion, so that there are really four exits for the escape of grain from the bottom of the box E, two on each side, thus making two grades of the grain drawn over through the tube B⁴, and two grades of the gleanings drawn over through the tube R. F is an ordinary fan, driven by the pulley F' on its shaft to create a suction-draft through the various tubes above described, and through the chambers D and E, and out at the exit T², as indicated by the arrows in the drawing. V is a slide, for opening and closing the bottom of the fan-drum V', for the purpose of regulating the draft of air. W are cross-pieces across the top of the scouring-cylinder, and serve to hold it in place, there being two of them, crossing each other at right angles. The sectional drawing being central, pass through those cross-pieces and give the scouring-cylinder the appearance of not opening into the chamber C, when, in fact, it opens into said chamber, it having no other cover excepting said cross-pieces W. W' is a frame, made of wood or other suitable material that is strong and durable.

Having thus fully described the construction and operation of our invention, what we claim, and desire to secure by Letters Patent, is—

1. The automatic valve B, in combination with the discharge-chute and scouring mechanism, all constructed and operating substantially as specified and shown.
2. The combination of the chamber D and the air-pipes R, C', and B⁴, when arranged as and for the purposes described.
3. The combination of the chambers D and E, the longitudinal and transverse inclined partitions U and U', and the fan F, constructed and arranged as and for the purpose set forth.

JOHN C. HUNT.

WILLIAM W. INGRAHAM.

Witnesses:

F. F. WARNER,

HEINR. F. BRUNS.