

B. H. Snavely
Thrashing Mach.
No 101,530. Patented Apr. 5, 1870.

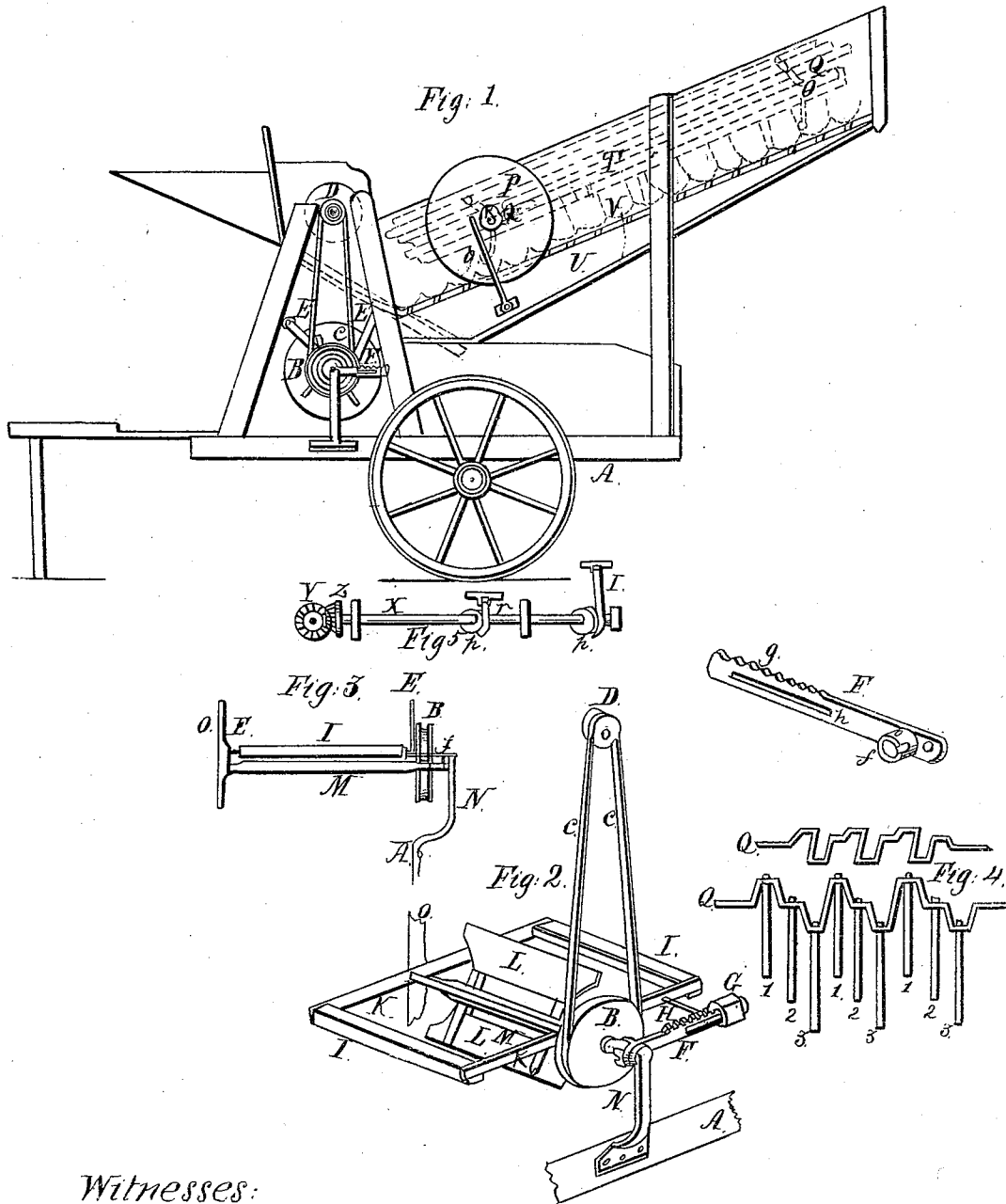

Witnesses:
W. B. Miley
Jacob Stauffer

Inventor:
Benjamin H. Snavely

UNITED STATES PATENT OFFICE.

BENJAMIN H. SNAVELY, OF PENN TOWNSHIP, LANCASTER COUNTY, PA.

IMPROVEMENT IN SEPARATORS.

Specification forming part of Letters Patent No. 101,530, dated April 5, 1870.

To all whom it may concern:

Be it known that I, BENJAMIN H. SNAVELY, of Penn township, in the county of Lancaster and State of Pennsylvania, have invented certain Improvements in Separators, of which the following is a specification.

The principal part of my invention relates to the regulation of the blast of the fan by means of a weighted lever-arm which is so arranged as to give the fan-shaft an eccentric bearing on one side and cause the belt to slacken, and thereby diminish the speed and make it self-adjusting, so as to keep it up to a fixed point, according to the adjustment of the weight on the lever-arm.

The drawings illustrate the construction, as well as minor improvements not specially claimed.

Figure 1 is a side elevation of the construction of my separator with the improvement in place. Fig. 2 is a perspective view, to illustrate the fan and weighted-lever arrangement; Fig. 3, the same, to show the several bearings; Fig. 4, the threefold triple crank Q and rake-arms 1 2 3; Fig. 5, side gear.

In order to give the minor improvements and arrangement of the parts deemed original with me, but which I have since learned were severally anticipated in the patents of Messrs. Bergen, Osborn, and Geiser, differing, however, in the arrangement and combination, that perhaps might entitle me to some claim. I will, however, simply mention them: First, the trough T of the conveyer has a threefold triple crank, Q Q, to which nine rakes are connected, the alternate third in unison, the teeth of which are so arranged with the stroke or crank motion as to bring them directly over an open slot made across the bottom V in their downward dip, while at certain intervals a hooked tooth is inserted, to hold the straw and aid in more effectually shaking out the grains that may be entangled therein.

P shows a large driving-pulley on the lower crank-shaft.

R is a triangular cam-pulley, with rounded corners, to operate the rod S, held in a pivot on the trough or side T, and secured by a joint in the plate w on lower bottom, U, and vibrates the same. On the opposite side of the machine, Fig. 5, I also use a horizontal shaft, x, geared by a bevel cog-wheel, Z, to one, Y, on the end of the fan-shaft. This horizontal shaft is provided with cams p, of a peculiar rounded quadrangular shape, and hinged spring-beaters r, connecting with the shoe and screen inside,

the arrangement of which produce remarkable results by their harmony of action; but I confine my claim to the device for regulating the blast. This consists of a lever-arm, F, with teeth g, for a sliding weight, G, and a longitudinal slot, h, for the rod H on the hanging frame I. This lever F has also a bearing, f, for the fan-shaft M, and terminated by a pivot-bearing, by which it is held in the bracket-arm N, fastened below to the bed-beam A, so that when the lever-arm is moved upward the fan-shaft is slightly raised, thereby slackening the belt C, which connects the fan-pulley B with the pulley D on the shaft of the spiked cylinder or thrasher. The same weighted lever, operated in like manner, but connected with a hanging pulley so arranged as to press against the belt to increase the speed, I have also tried; (the bearing of the fan-shaft in that case was stationary,) but, after trial, find the arrangement shown to be the most satisfactory.

The swinging frame I I, with its cross-strips K, is balanced centrally above the fan-shaft M in bearings E. The fan L revolves between this swinging frame, and when driven with excess of speed will cause the frame I to raise on the inner side, and, being connected with the slotted lever-arm F by the connecting-rod H, will actuate the lever and slacken the belt in the manner before stated. The sliding weight on the lever-arm is to adjust the tension of the bolt and regulate the degree of the current or speed of the fan to a certain fixed standard, to which the fan is held by the counterpoise adapted to the required speed.

I am aware that various devices are employed to regulate the action of the fan in separators; but I am not aware that a weighted lever calculated to tighten or slacken the belt which connects the cylinder and fan-pulleys was ever before used for that purpose; therefore,

What I claim as my invention, and desire to secure by Letters Patent, is—

The slotted lever-arm F, with its sliding weight G, in combination with the swinging frame I K, with its connecting-rod H, for the purpose of acting upon the belt c, which actuates the fan-pulley B, for the purpose of regulating the speed of the fan, substantially in the manner and for the purpose specified.

BENJAMIN H. SNAVELY.

Witnesses:

WM. B. WILEY,
JACOB STAUFFER.