

Feb. 19, 1929.

1,702,996

LA RUE R. COPPAGE
COMBINED HOLDER AND CASE

Filed April 13, 1928

2 Sheets-Sheet 1

Fig. 1.

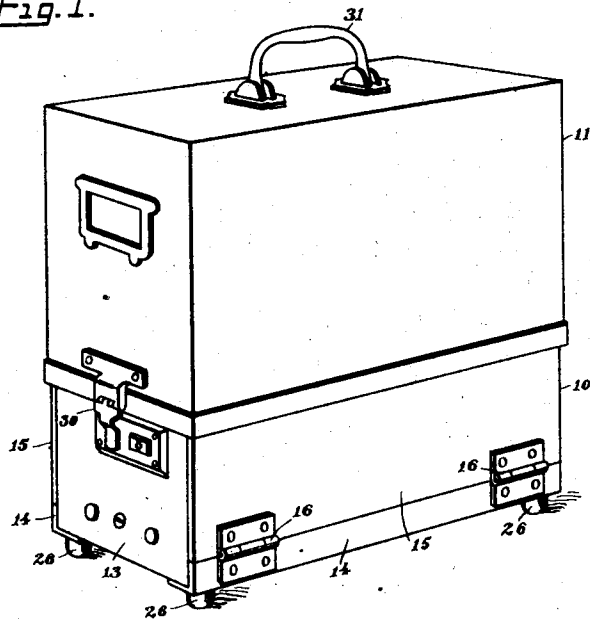
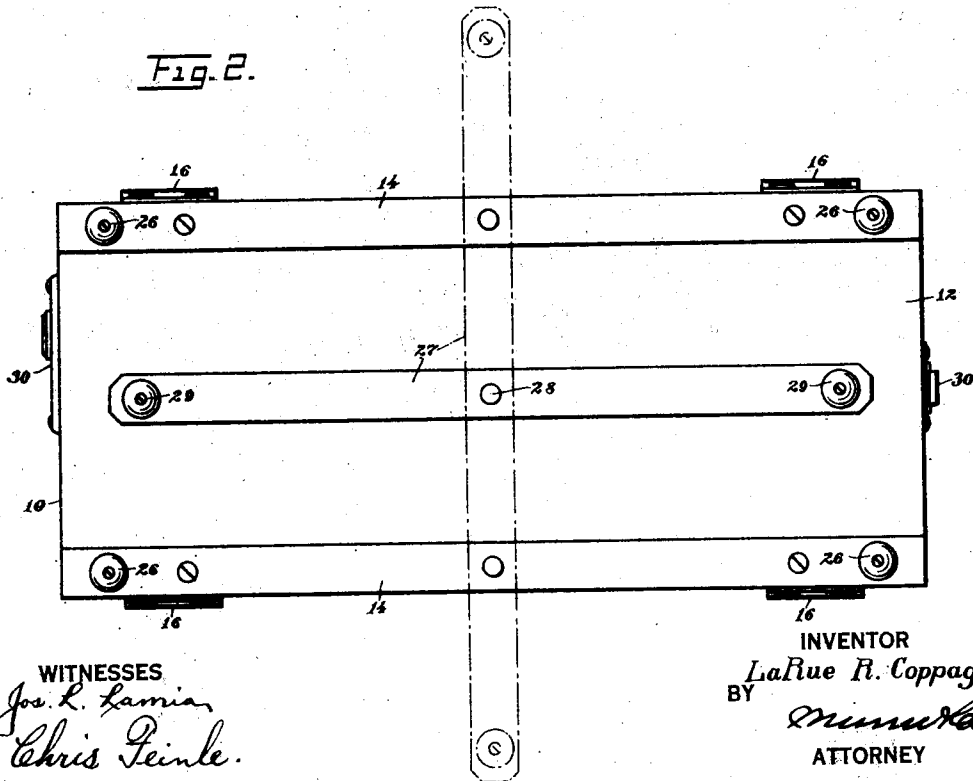

Fig. 2.



WITNESSES
Jos. L. Lamin
Chris Seinke

INVENTOR
LaRue R. Coppage
BY *Munich*
ATTORNEY

Feb. 19, 1929.

LA RUE R. COPPAGE
COMBINED HOLDER AND CASE

Filed April 13, 1928

1,702,996

2 Sheets-Sheet 2

Fig. 3.

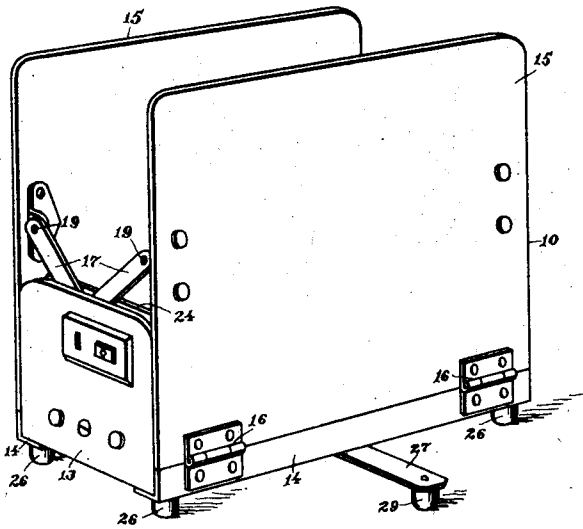

Fig. 5.

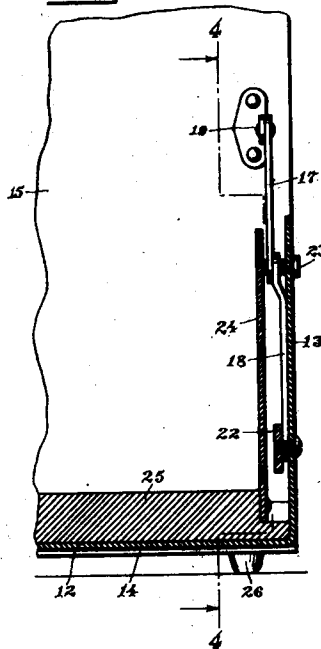
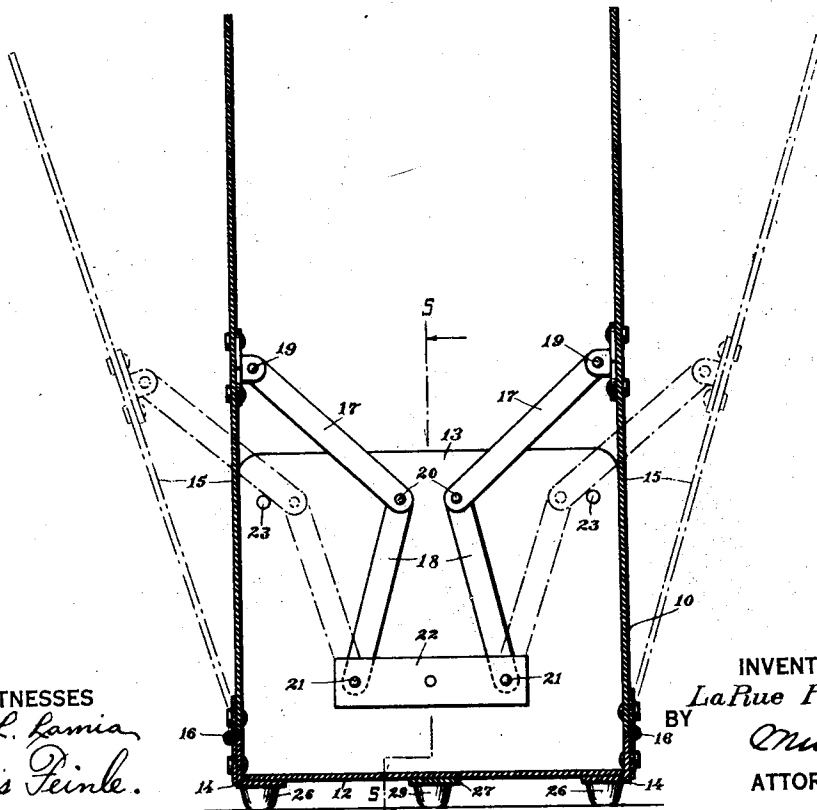

Fig. 4.



WITNESSES
Jos. L. Samia
Chris Feink.

INVENTOR
LaRue R. Coppage
BY
Amundson
ATTORNEY

UNITED STATES PATENT OFFICE.

LA RUE R. COPPAGE, OF BROOKLYN, NEW YORK, ASSIGNOR TO THE COPPAGE PRINTING AND LOOSE LEAF COMPANY, OF NEW YORK, N. Y., A CORPORATION OF NEW YORK.

COMBINED HOLDER AND CASE.

Application filed April 13, 1928. Serial No. 269,813.

This invention relates to a combined holder and case for cards, sheets, or a ledger used in bookkeeping systems.

Some of the objects of the invention are: to provide a portable means of the indicated character which may be used as a holder for the cards, sheets, or a ledger to be carried from one place to another for the desired purposes; to enable a person to remove the cards, sheets, or the ledger for posting entries, or for handling the cards, sheets or the ledger for any purpose; to completely enclose the cards, sheets, or the ledger under lock and key at the close of a day; and to provide a portable means of the indicated character which will embody improved features of construction.

The nature of the invention and its distinguishing features and advantages will appear when the following specification is read in connection with the accompanying drawing, in which—

Figure 1 is a perspective view of the combined holder and case.

Fig. 2 is a bottom plan view.

Fig. 3 is a perspective view of the holder, there being a ledger arranged therein.

Fig. 4 is a transverse sectional view, the section being taken substantially on the line 4—4 of Fig. 5.

Fig. 5 is a sectional view taken on the line 5—5 of Fig. 4.

The article of the invention comprises a holder 10, for cards, sheets, or a ledger, and a case section, box or cover 11 adapted to be associated with the holder 10 for completely enclosing the cards, sheets or the ledger. The parts may be made of any preferred material and are preferably made of metal, mainly sheet metal.

The holder 10 includes a part of sheet metal formed to provide a bottom 12, and ends 13 integral with the bottom 12. A cross-sectionally L-shaped member or angle iron 14 is secured to each side edge of the bottom 12. Hingedly connected with the upper edge of each of the members 14 is a side plate 15, the hinges being indicated at 16. The side plates 15 are movable relatively toward and away from each other, and have limited movement away from each other by the provision of any suitable means. The plates 15 extend above the ends 13. In the present instance the said means consists of two pairs of members 17 and 18 associated with each side plate 15 and

each of the ends 13. One end of each member 17 is pivotally connected as at 19 with its side plate 15, the opposite end thereof is pivotally connected as at 20 with one end of the related member 18, and the opposite end of the member 18 is pivotally connected as at 21 with the related end 13. Use is made of a member 22 for maintaining an effective pivotal connection of the members 18 with the related end 13. Stops 23 carried by each end 13 cooperate respectively with the members 17 for limiting the outward swinging movement of the side plates 15, as shown most clearly in dotted lines in Fig. 4. If desired the holder 10 may have arranged in each end thereof a guard plate 24 secured at the lower edge to a block 25 secured to the bottom 12. Each plate 24 is disposed on the inside of the related members 17 and 18, and prevents the edges of the articles placed in the holder from interfering with the movement of the members 17 and 18. The bottom 12 on the under side thereof is provided with rubber cushions or feet 26 on which the holder rests. In order to give greater stability to the holder there is provided a member or bar 27 pivotally connected as at 28 with the bottom 12, the opposite ends respectively of the bar 27 having cushions or feet 29. The said bar 27 is adapted to be brought to a longitudinally disposed position beneath the bottom 12, as shown in full lines in Fig. 2, or to a transversely disposed position as shown in dot and dash lines in Fig. 2, or as shown in Fig. 3, for the purpose mentioned.

The case section, box or cover 11 is adapted to be brought down over the side plates 15, and is so constructed as to constitute with the holder 10 a case for completely enclosing the cards, sheets or a ledger arranged in the holder 10. Suitable latching devices 30 are provided to hold the cover 11 in place on the holder 10. Each latching device consists of parts respectively on an end of the cover 11 and the end 13 of the holder 10. One of the latches is key operated for the purpose of locking the cover 11 in place on the holder 10. The cover 11 has a handle 31 for the purpose of carrying the article.

I claim:

A holder of the class described comprising a bottom, ends connected with the bottom, and side plates hingedly connected respectively with the side edges of the bottom so that they may be swung toward and away from

each other, and means limiting the swinging movement of the plates away from each other, said means comprising pairs of link members, the link members of each pair being pivotally connected together, one link member of each pair being pivotally connected with one of the ends of the holder, and the other link member being pivotally connected with one of said plates, and a stop on the related end of the holder which is engageable by one of

said link members of each pair, each pair of link members being disposed on the inside of the related end of the holder, and a guard plate secured to said bottom and disposed on the inside of the related link members. 15

Signed at New York in the county of New York and State of New York this 10th day of April, A. D. 1928.

LA RUE R. COPPAGE.