

S. Carrvbell.
Laying Mach.

N^o. 6,785.

Patented Oct. 9, 1849.

Fig. 1.

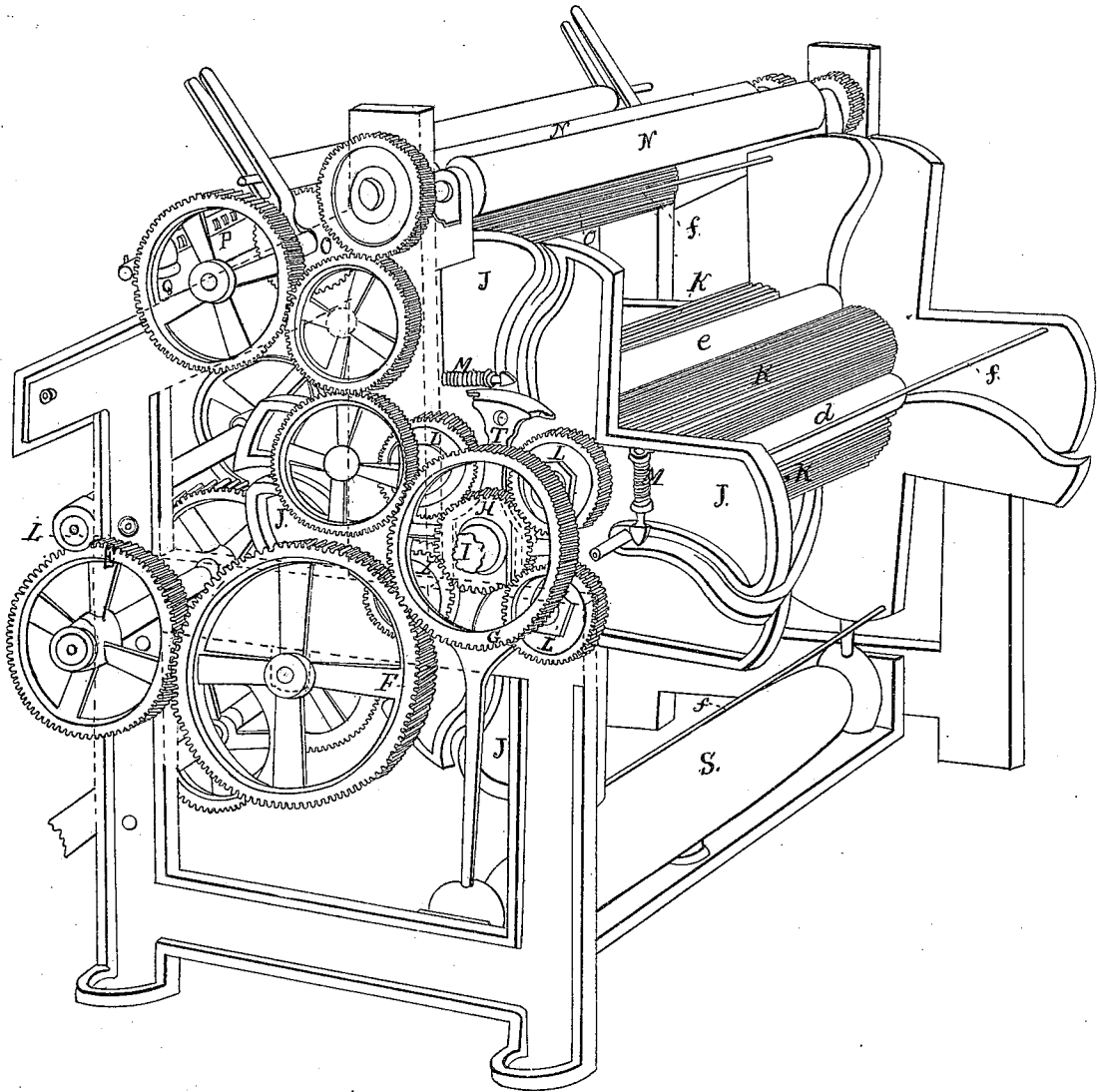

S. Campbell. Laying Mach.

N^o 6785.

Patented Oct. 9, 1849.

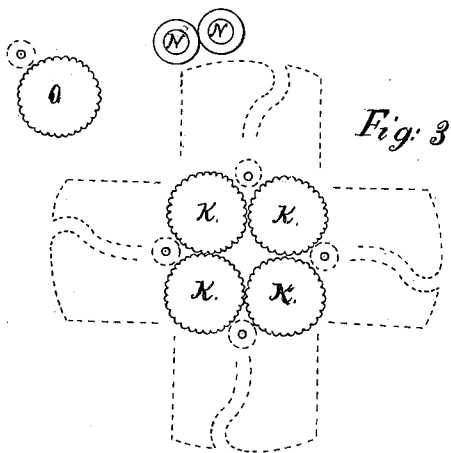
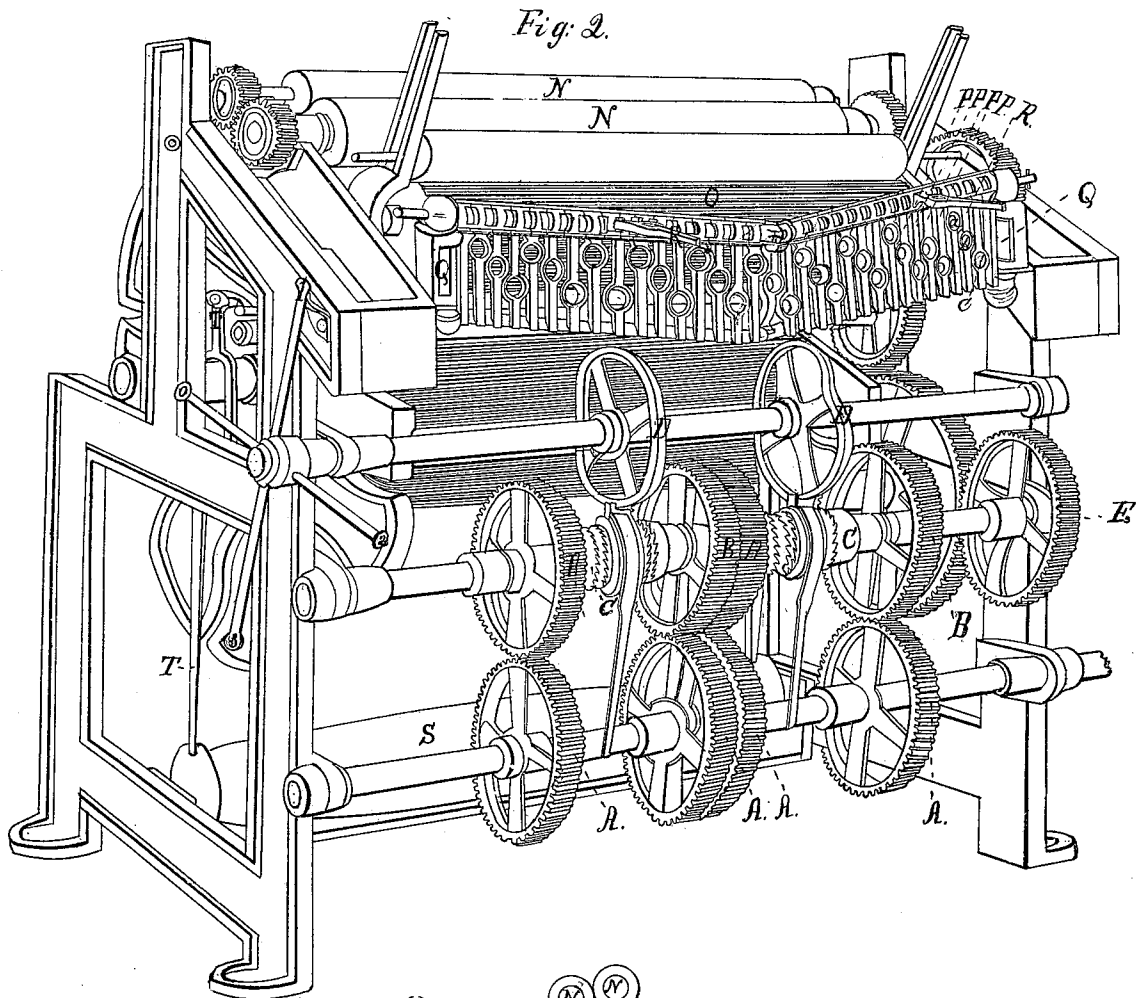

UNITED STATES PATENT OFFICE.

SAMUEL CAMPBELL, OF NEW YORK MILLS, NEW YORK.

LAPPING-MACHINE.

Specification of Letters Patent No. 6,785, dated October 9, 1849.

To all whom it may concern:

Be it known that I, SAMUEL CAMPBELL, of New York Mills, in the county of Oneida and State of New York, have invented certain new and useful Improvements in the Lapping-Machine Used in Cotton Manu-
5 factories for Preparing Laps for Carding.

With the improved lapper the lap can be instantly changed or removed, without stop-
10 ping the movement of the material from which the lap is made and may be used at any place where the common lapper is used; but its usefulness will be especially realized in forming laps immediately from breaker
15 cards in wholly preventing the necessity of stopping the doffers and feeding rollers while changing the laps, thus, not only saving time but preventing an imperfection in the carding, caused by stopping the doffers
20 and feeding rollers, every time the lap is removed or changed; and I do hereby declare that the following is a clear and exact description of the construction and operation of the same, reference being had to the
25 annexed drawings, making them a part of this specification, and in which—

Figure 1 and Fig. 2 are perspective views. Fig. 3 a transverse section.

Motion is given to the machine at the end
30 of the shaft on which is placed the driving gears A A A A, Fig. 2.

B B B B are loose gears so arranged as to give the proper speed to any required number of cards, either one of which is made fast
35 by the catch boxes *c, c*, which can be readily moved while the machine is in operation, by the transverse wheels D D and the handles 0, 1, 2, 3, the figure that is up corresponding to the number of cards stopped. The traverse wheels are so constructed that only one
40 of the catch boxes can be in gear at one time.

E Fig. 1, is a fast gear. F a carrier.

G and H are gears made fast to a collar that is fitted to the shaft I and forms its
45 bearing. On the shaft I are made fast two flanches, each divided into four compartments or heads J J J J, together with the four rollers K K K K, having their bearings in the two flanches and receiving motion
50 through their respective gears L L L L, from the gear H each head being nearly the same and answering the same purpose as the head of the common lapping machine.

M M M M are spring catches that confine

the empty lap rolls *d, e*, in the slits of their
55 respective heads.

N, N, are calender rollers.

O is a doubling roller, (or in place of one there may be two doubling rollers and a
60 roller, or canvas, apron, between the doubling and calender rollers,) by which the lap can be doubled, for example should the machine be used with twenty cards, twenty
65 strands, will form the first lap or laps, but by placing one of the laps already made on the doubling roller and running it in with the strands coming from the cards you will
70 have a lap with forty strands, and again, if you choose, with sixty.

P, P, P, P, Fig. 2, are adjusting guides
75 corresponding to the number of cards in use at the machine and are suspended on an iron rod or frame of suitable length and size. The frame is made with two rods, each
80 having an elbow joint in the middle; one rod is placed over the other and the middle guide instead of being suspended, may be so constructed at each end as to form the pivots for the joints of both rods, thus connecting
85 the rods at the middle the desired distance apart. On the sides of the frame are fixed two stands serving as bearings for the pillars Q, Q, which have a rotary motion. In
90 each pillar are two holes in which are inserted the ends of the rods, thus supporting the rods or frame and forming a bearing through which the frame can be moved end-
95 wise; which, together with the rotary motion of the pillars and the elbow joints, the frame may be drawn out from either or both sides any necessary length by increasing the
100 angle of the two sides and is thus regulated to suit the number of cards in operation. The guides are suspended on the upper rod, the lower end resting against the bottom
rod. Each guide has a suitable aperture through which its respective strand passes, these apertures are placed as at *a, b, c*. Intersecting each other and giving each aperture
105 a wider space than its mean diameter, which will allow the edges of the strands to overlap each other, making the surface of the lap more level and uniform.

When it becomes necessary to stop one or more cards which are in use at the machine,
105 then the guides through which the strands passed from the cards just stopped must be raised up from a perpendicular to a hori-

zontal position. The frame having been fully extended is then pushed inward and the guides by their peculiar construction will then occupy the interstices between the adjoining guides as shown at R R and producing a uniform division between the remaining guides or strands.

In operating the machine the heads are brought into use alternately, the ascendant head is held in its place by the weight S, being suspended on the gudgeons of the lap rolls by a saddle, (having a small bearing,) that is attached to the inside and upper end of the suspenders T T and which suspenders straddle the shaft I. When the lap becomes full, the operator by a gentle push can change the position of the heads one quarter around, thus, with the assistance of the rods *f, f*, instantly breaking off and withdrawing the full lap, and placing the next head with an empty roller in a position ready for use. The full lap can be removed at leisure and

an empty roller put into its place. The stands are brought to the machine in the same manner as to a rail road head. 25

What I claim as my invention and desire to secure by Letters Patent is—

The manner in which the heads are constructed and arranged so as to revolve in removing or changing the laps. Also the introduction of the doubling roller as part of the same machine, and the manner in which the adjusting guides are constructed so that one or more can be displaced and the remainder uniformly divided into the same space occupied by the whole, whether the arrangements are precisely the same as herein represented, or in any other manner which is substantially the same and producing a like result upon the same principle. 30 35

SAMUEL CAMPBELL.

Witnesses:

JOHN HARVEY,
ISAAC MAINS.