

Aug. 12, 1924.

1,504,832

M. POUGET

CULINARY APPARATUS

Filed Nov. 22, 1919

3 Sheets-Sheet 1

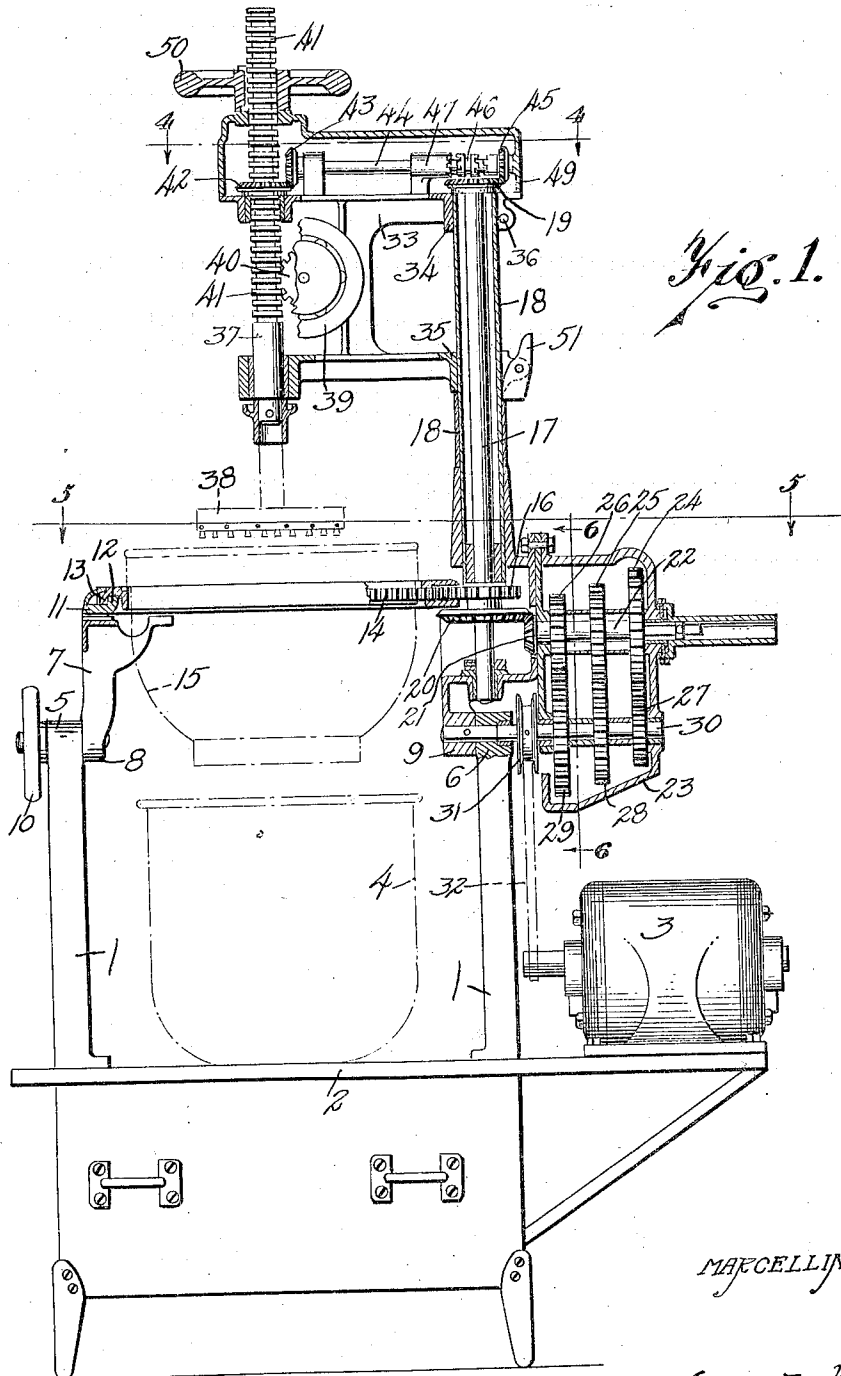

Fig. 1.

Inventor
MARCELLIN POUGET.

Charles E. Wiener
Attorney

334

Aug. 12, 1924.

1,504,832

M. POUGET

CULINARY APPARATUS

Filed Nov. 22, 1919

3 Sheets-Sheet 2

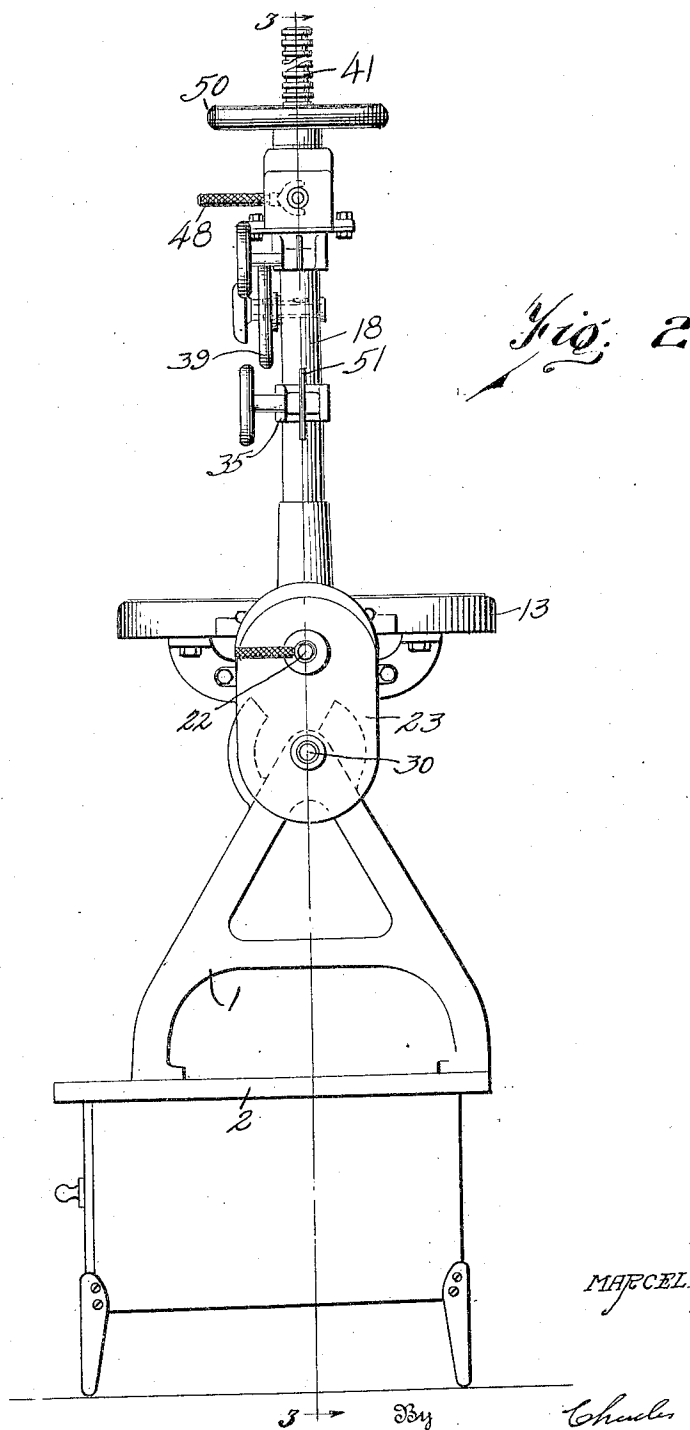

Inventor
MARCELLIN POUGET.

Charles E. Wisner
Attorney

Aug. 12, 1924.

1,504,832

M. POUGET

CULINARY APPARATUS

Filed Nov. 22, 1919

3 Sheets-Sheet 3

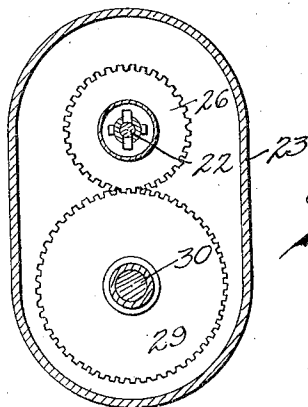
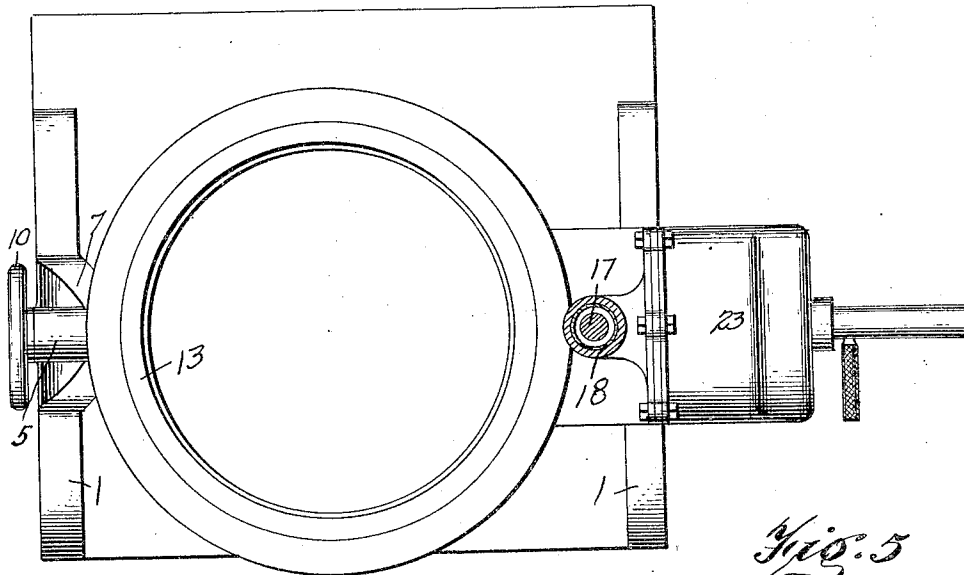
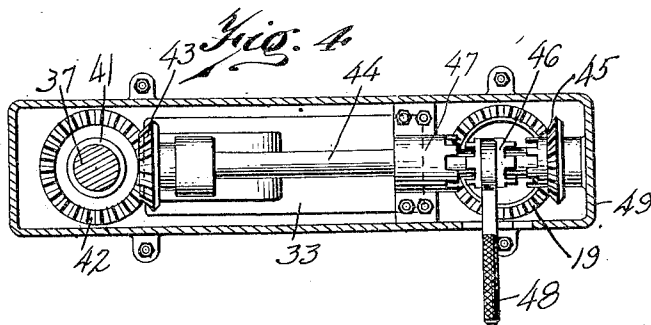

Inventor
MARCELLIN POUGET.

By *Charles E. Vicker*
Attorney

UNITED STATES PATENT OFFICE.

MARCELLIN POUGET, OF DETROIT, MICHIGAN.

CULINARY APPARATUS.

Application filed November 22, 1919. Serial No. 339,783.

To all whom it may concern:

Be it known that I, MARCELLIN POUGET, a citizen of the Republic of France, residing at Detroit, county of Wayne, State of Michigan, have invented a certain new and useful Improvement in Culinary Apparatus, and declare the following to be a full, clear, and exact description of the same, such as will enable others skilled in the art to which it pertains to make and use the same, reference being had to the accompanying drawings, which form a part of this specification.

This invention relates to culinary apparatus adapted for the preparation of various foods for consumption, and an object of the invention is to provide a simple and comparatively inexpensive device for the cutting, slicing, grating or mashing of raw or cooked materials, it being understood that various types of disintegrating tools and appliances are used in conjunction with the machine. The machine involves a framework providing a support for a receptacle into which the prepared material may be finally dispensed and a receptacle in which the cutting, slicing or disintegrating operations are performed.

The principal feature of the invention is involved in providing a framework supporting the said second receptacle in a manner whereby it may be rotated about a vertical axis at various speeds and in the arrangement of the driving mechanism and supporting frame in a manner to permit the turning of the frame and receptacle about a horizontal axis for the purposes hereinafter described. Another feature of the invention is in the provision of mechanism for operating the various cutting, mashing or disintegrating heads, which mechanism may be turned to one side or the other of the vertical axis of the second receptacle above mentioned, and further features are involved in the mechanism for raising or lowering the disintegrating member out of or into the receptacle, and the means employed for actuating the disintegrating head or holding the same from actuation during the rotation of the receptacle. These objects and the several novel features of the invention are hereinafter more fully described and claimed and the preferred form of the mechanism embodying my invention is shown in the accompanying drawings in which—

Fig. 1 is an elevation partly in section of

my improved culinary apparatus taken on line 3—3 of Fig. 2.

Fig. 2 is an end elevation thereof taken from the right hand side of Fig. 1.

Fig. 3 is a section taken on line 6—6 of Fig. 1.

Fig. 4 is a section taken on line 4—4 of Fig. 1.

Fig. 5 is a section taken on line 5—5 of Fig. 1.

The apparatus consists of the main frame or base member 1 having a platform 2 on which is supported a driving motor 3 and a receptacle indicated by dotted lines 4 for the prepared material. This base member 1 has frame members upwardly extending from the base and platform 2 terminating in bearings 5 and 6. An upper framework 7 is provided having members 8 and 9 apertured to receive the shafts in the perspective bearing members 5 and 6 whereby the upper framework may be turned about a horizontal axis. A hand wheel 10 is provided on the shaft of one of the said bearing members which is to be understood as being threaded to bind the bearing members 5 and 8 together to hold the upper framework at the desired angle to the vertical. The upper end of this frame member 7 is provided with a circular frame portion 11 having an inner upturned flange 12 on which is mounted the ring member 13 having a circumferential groove in the lower side fitting over the said flange. This member 13 has an external gear 14 formed therein and within this ring 13 is supported a second receptacle indicated by dotted lines 15 in Fig. 1. The construction of the inner flange of the member 12 and of the receptacle 15 is such as to permit the ready insertion or removal of the receptacle from the ring, the receptacle snugly fitting in the ring when positioned therein so that rotation of the ring rotates the receptacle. The ring gear 14 meshes with its driving gear 16 on the vertical shaft 17 supported at the lower end in a bearing provided in the member 9 and extending upwardly through a tubular housing 18 and terminating in a bevel gear 19 at the upper end. A bevel gear 20 is provided adjacent the lower end of the shaft 17 driven by a bevel gear 21 on the horizontal shaft 22 of the transmission gearing supported in a housing 23 secured to the frame member 7 at the lower end of the housing 18. The shaft 22 is provided with several gears 24,

25, and 26 meshing with the companion gears 27, 28, and 29 respectively on the driving shaft 30, which shaft is positioned with the longitudinal axis in alignment with the longitudinal axis of the bearing members 6 and 9 about which the frame member 7 may be turned. The shaft 30 is driven by means of a belt wheel 31 connected by means of a belt 32 with a belt wheel on the shaft of the motor 3. The transmission gearing herein shown is to be understood as being of a character to control the speed of rotation of the shaft 22 and consequently of the shaft 17 and ring gear 14 and the speed of rotation is varied by attaching one or the other of the gears 24, 25, or 26 to the shaft 22 on which they are normally revoluble. The mechanism may be of any approved character permitting a variation in the speed of operation of the shaft 17. The details of construction of the specific transmission gearing are here shown only in outline (the subject-matter of a separate application filed simultaneously herewith).

The cutting or disintegrating tool head 33 is provided with upper and lower bearings 34 and 35 revolubly supported upon the tubular housing 18 and both the said bearings are split bearings, the upper bearing having a bolt 36 of a character to clamp the bearing member on the tubular member 18 to hold the same in fixed position when so desired. The frame member 33 carries at the outer end thereof a shaft 37 rotatably and reciprocally mounted in bearings provided in the frame therefor. The shaft carries at the lower end various cutting and disintegrating tools heretofore mentioned one of which is indicated by dotted lines 38. This shaft is reciprocable in the bearings by means of a hand wheel 39 on the shaft of which is a gear 40 which meshes with the rack 41 formed on the shaft 37. This rack is peculiar in character being formed in parallel spaced ring like portions, the spaces therebetween being less in diameter than the rings. By this construction the shaft may rotate while in mesh with the gear 40 and be moved upward or downward during its rotation.

To rotate the shaft 37 a bevel gear 42 is splined on the rack portion thereof and meshing with which is a bevel gear 43 on the horizontal shaft 44 riding in bearings provided on the frame member 33. At the rear end of this shaft is revolubly mounted a bevel gear 45 meshing with the gear 19 on the vertical shaft 17. A two-faced clutch member is splined to the shaft between the bearing 47 and the gear 45, the hub of the gear being provided with a companion clutch for one of the said clutch faces and the bearing member 47 being provided with a clutch member companion to the other of the said faces of the clutch 46. This clutch

may be operated in any approved manner as by the handle 48 shown in Figs. 2 and 4 which extends outwardly through the casing 49 on the top of the frame member 33. The clutch 46 is splined to the shaft and by movement of the clutch member to engage the gear 45 the shaft 44 is rotated which rotates the shaft 37. If it be desired to hold the shaft from rotation the clutch member 46 is moved to engagement with the companion on the bearing member 47 and it may be desirable to hold the shaft 37 from rotation during rotation of the receptacle 15 in which mode of operation whatever material is being used is forced against the disintegrating member on the end of the shaft 37. When in operation this shaft 37 is moved downward bringing the head 38 into the receptacle and into engagement with the material therein. It is sometimes desirable to turn the shaft 37 by hand and to accomplish this the clutch member 46 is moved to neutral position which is the position shown in Fig. 1. The disintegrating member is moved downward into the receptacle 15 and the shaft 37 is turned by means of the hand wheel 50 on the upper end thereof which is splined to the shaft permitting its reciprocation through the hand wheel and enabling it to turn the shaft by rotation of the wheel. It is oftentimes desirable to position the disintegrating head to one side or the other of the center of the receptacle 15 and to hold the said head in such position the lower bearing 35 of the frame member is provided with a pawl 51 engaging in notches which are to be understood as being formed in the outside housing 18 of the shaft 17. While not here shown several notches may be provided in which the pawl may be introduced and whereby the frame and the head thereon is held to one side of the vertical axis of the pawl or receptacle 15. To permit this turning of the frame 33 the clamping bolt 36 should be loosened.

Oftentimes a small quantity of material is to be operated upon and, as the receptacle 15 is of considerable size, it is necessary to tilt the receptacle slightly to cause material to flow or accumulate on one side and for this purpose the frame member 7 and apparatus supported thereon, which includes the receptacle 15, may be turned on the trunnions or bearings 5 and 6 by first loosening the wheel 10 and positioning the upper framework at the desired angle and then securing the wheel 10.

From the foregoing description it becomes evident that the device is comparatively simple in construction and that the several objects of the invention are attained in an efficient manner and by pivotally supporting the driving mechanism, receptacle and disintegrating head on the frame pivotally supported on a horizontal axis, the device is

adapted to operate upon a large or small quantity of material as stated. It is to be noted particularly that in order that this upper framework and parts supported thereon including the driving gears may be turned by the driving shaft it must have its longitudinal axis in alignment with the turning axis of the framework whereby in turning the said framework, driving and disintegrating mechanisms supported thereon the driving shaft is not altered in its relationship with the motive power.

Having thus fully described my invention, what I claim and desire to secure by Letters Patent of the United States is—

1. In apparatus of the character described, a framework comprising a base part and upper part pivoted to swing thereon on a horizontal axis, a rotatable element on the said upper part including a receptacle, rotatable apparatus adapted to be positioned within or withdrawn from the said rotatable element, and means for rotating the said element and apparatus including a driving shaft, the longitudinal axis of which is in alignment with the turning axis of the upper frame.

2. In apparatus of the character described, a framework comprising a base part and an upper part pivoted to swing thereon on a horizontal axis, a rotatable element carried by the upper part and adapted to hold a receptacle, a vertical shaft carried by the said upper part positioned over the said element and receptacle and adapted to be moved downward and into or withdrawn from the receptacle, said upper part of the framework being further adapted to be turned on a vertical axis permitting the said vertical shaft to be moved to one side or the other of the center of the receptacle, a lock-

ing device for holding the framework in a predetermined position, a driving means common to the receptacle element and to the said vertical shaft, means for connecting or disconnecting the vertical shaft with the driving means, and means for holding the vertical shaft from rotation.

3. In apparatus of the character described, a framework comprising a base and an upper part pivoted to swing thereon on a horizontal axis, a vertically movable and rotatable shaft carried by the said upper part of the frame, manual means for moving the shaft, said upper part of the framework carrying the shaft being mounted to turn about a vertical axis at one side of the axis of the shaft, means for positioning the said portion of the frame at predetermined points about its axis, a vertical driving shaft positioned on the vertical axis of the said upper part of the frame, means for connecting or disconnecting the vertical driving shaft with the vertically movable shaft, and driving means for the said driving shaft including a horizontal shaft mounted on the horizontal axis of the upper and lower parts of the framework.

4. In culinary apparatus, a framework comprising a base part and an upper part pivotally supported thereon to turn on a horizontal axis, a rotatable element carried by the upper framework, a shaft for rotating the same, a speed-changing power transmission device comprising a shaft geared to the said first named shaft, and a driving shaft, said driving shaft being positioned with longitudinal axis in alignment with the turning axis of the upper frame.

In testimony whereof, I sign this specification.

MARCELLIN POUGET.