



(86) Date de dépôt PCT/PCT Filing Date: 2014/01/07  
 (87) Date publication PCT/PCT Publication Date: 2014/07/17  
 (45) Date de délivrance/Issue Date: 2017/07/11  
 (85) Entrée phase nationale/National Entry: 2015/07/02  
 (86) N° demande PCT/PCT Application No.: EP 2014/050112  
 (87) N° publication PCT/PCT Publication No.: 2014/108378  
 (30) Priorité/Priority: 2013/01/09 (DE102013200211.4)

(51) Cl.Int./Int.Cl. *E04F 13/08* (2006.01),  
*E04B 1/76* (2006.01)

(72) Inventeurs/Inventors:  
 PETZOLD, FLORIAN, DE;  
 ABBAS, SHAHBAZ, AT;  
 BROCKMULLER, KAY, DE;  
 WUST, ANDREAS, DE;  
 HENSEL, TORSTEN, DE;  
 USKE, KLAUS, DE

(73) Propriétaire/Owner:  
 HILTI AKTIENGESELLSCHAFT, LI

(74) Agent: ROBIC

(54) Titre : CONSOLE THERMIQUEMENT ISOLANTE PERMETTANT DE RELIER UNE FACADE A UNE PAROI D'IMMEUBLE

(54) Title: HEAT-INSULATING CONSOLE FOR JOINING A FACADE TO A BUILDING WALL

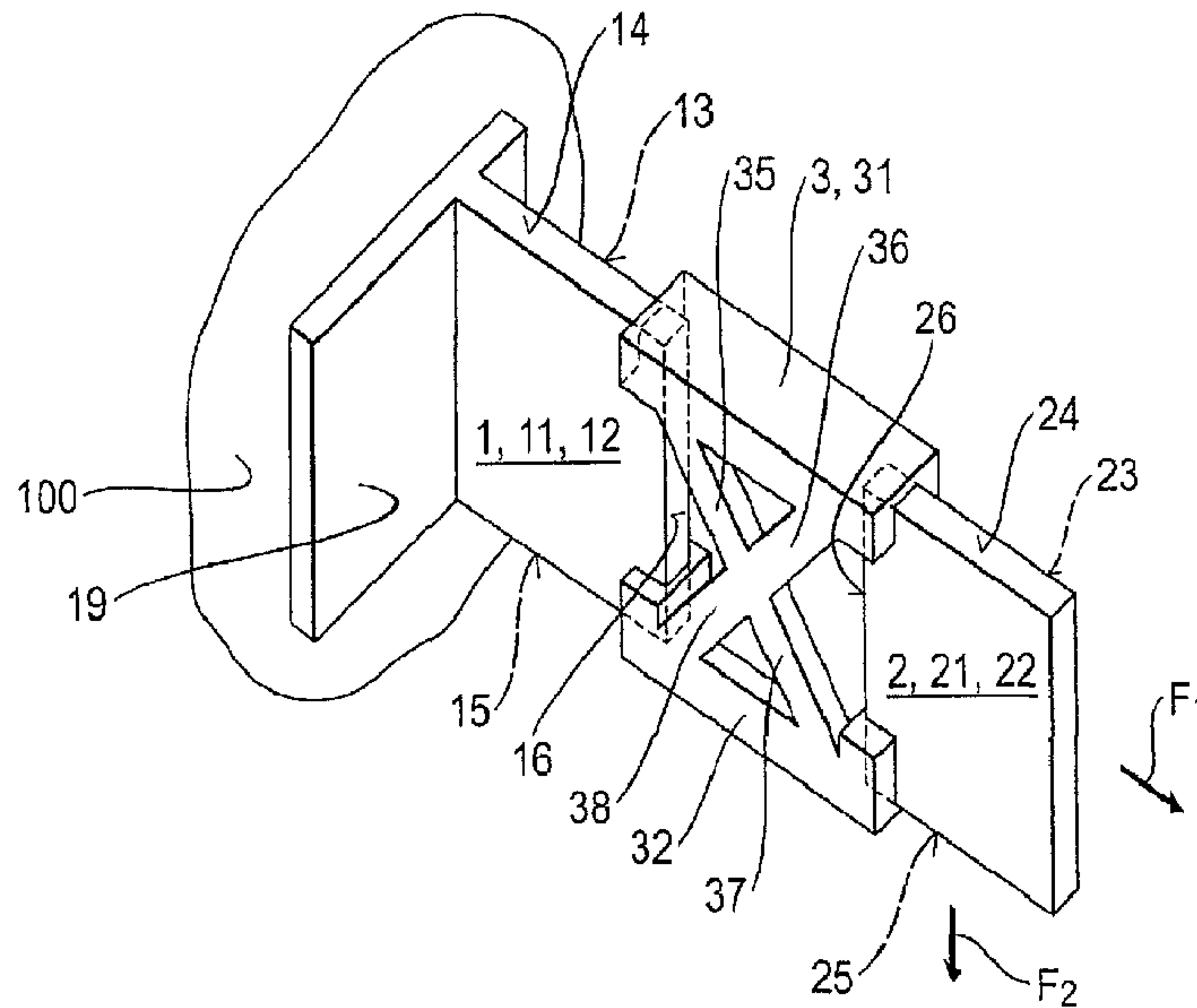

(57) Abrégé/Abstract:

The invention relates to a bracket for connecting a façade to a building wall (100), comprising a metal wall part (1) for installing on the building wall, a metal façade part (2) for connecting to the façade, and a bridge part (3), which connects the façade part to the

(57) **Abrégé(suite)/Abstract(continued):**

wall part, wherein the bridge part is composed of a plastic material and forms a heat barrier between the wall part and the façade part. According to the invention, the bridge part (3) is an injection-moulded part made of fibre-reinforced plastic and the bridge part is moulded over the wall part (1) and the façade part (2) in some areas of the wall part and of the façade part.

## (12) NACH DEM VERTRAG ÜBER DIE INTERNATIONALE ZUSAMMENARBEIT AUF DEM GEBIET DES PATENTWESENS (PCT) VERÖFFENTLICHTE INTERNATIONALE ANMELDUNG

(19) Weltorganisation für geistiges

Eigentum

Internationales Büro

(43) Internationales  
Veröffentlichungsdatum

17. Juli 2014 (17.07.2014)



(10) Internationale Veröffentlichungsnummer

WO 2014/108378 A1

(51) Internationale Patentklassifikation:

E04F 13/08 (2006.01) E04B 1/76 (2006.01)

(21) Internationales Aktenzeichen: PCT/EP2014/050112

(22) Internationales Anmeldedatum:

7. Januar 2014 (07.01.2014)

(25) Einreichungssprache: Deutsch

(26) Veröffentlichungssprache: Deutsch

(30) Angaben zur Priorität:

102013200211.4 9. Januar 2013 (09.01.2013) DE

(71) Anmelder: HILTI AKTIENGESELLSCHAFT [LI/LI];  
Feldkircherstr. 100, CH-9494 Schaan (LI).(72) Erfinder: PETZOLD, Florian; Gutenbergstrasse 9, 89073  
Ulm (DE). ABBAS, Shahbaz; Pilgramgasse 24/7, A-1050  
Wien (AT). BROCKMÜLLER, Kay; Von-Geissel-  
Strasse 15, 67425 Neustadt (DE). WÜST, Andreas;  
Brisighellastrasse 2, 64673 Zwingenberg (DE). HENSEL,  
Torsten; Siegfriedstrasse 44, 64625 Bensheim (DE).  
USKE, Klaus; Hausener Weg 8a, 67098 Bad Dürkheim  
(DE).(81) Bestimmungsstaaten (soweit nicht anders angegeben, für  
jede verfügbare nationale Schutzrechtsart): AE, AG, AL,AM, AO, AT, AU, AZ, BA, BB, BG, BH, BN, BR, BW,  
BY, BZ, CA, CH, CL, CN, CO, CR, CU, CZ, DK, DM,  
DO, DZ, EC, EE, EG, ES, FI, GB, GD, GE, GH, GM, GT,  
HN, HR, HU, ID, IL, IN, IR, IS, JP, KE, KG, KN, KP, KR,  
KZ, LA, LC, LK, LR, LS, LT, LU, LY, MA, MD, ME,  
MG, MK, MN, MW, MX, MY, MZ, NA, NG, NI, NO, NZ,  
OM, PA, PE, PG, PH, PL, PT, QA, RO, RS, RU, RW, SA,  
SC, SD, SE, SG, SK, SL, SM, ST, SV, SY, TH, TJ, TM,  
TN, TR, TT, TZ, UA, UG, US, UZ, VC, VN, ZA, ZM,  
ZW.(84) Bestimmungsstaaten (soweit nicht anders angegeben, für  
jede verfügbare regionale Schutzrechtsart): ARIPO (BW,  
GH, GM, KE, LR, LS, MW, MZ, NA, RW, SD, SL, SZ,  
TZ, UG, ZM, ZW), eurasisches (AM, AZ, BY, KG, KZ,  
RU, TJ, TM), europäisches (AL, AT, BE, BG, CH, CY,  
CZ, DE, DK, EE, ES, FI, FR, GB, GR, HR, HU, IE, IS, IT,  
LT, LU, LV, MC, MK, MT, NL, NO, PL, PT, RO, RS, SE,  
SI, SK, SM, TR), OAPI (BF, BJ, CF, CG, CI, CM, GA,  
GN, GQ, GW, KM, ML, MR, NE, SN, TD, TG).

Veröffentlicht:

— mit internationalem Recherchenbericht (Artikel 21 Absatz  
3)

[Fortsetzung auf der nächsten Seite]

(54) Title: HEAT-INSULATING BRACKET FOR CONNECTING A FAÇADE TO A BUILDING WALL

(54) Bezeichnung : WÄRMEISOLIERENDE KONSOLE ZUM VERBINDEN EINER FASSADE MIT EINER GEBÄUDEWAND

Fig. 1

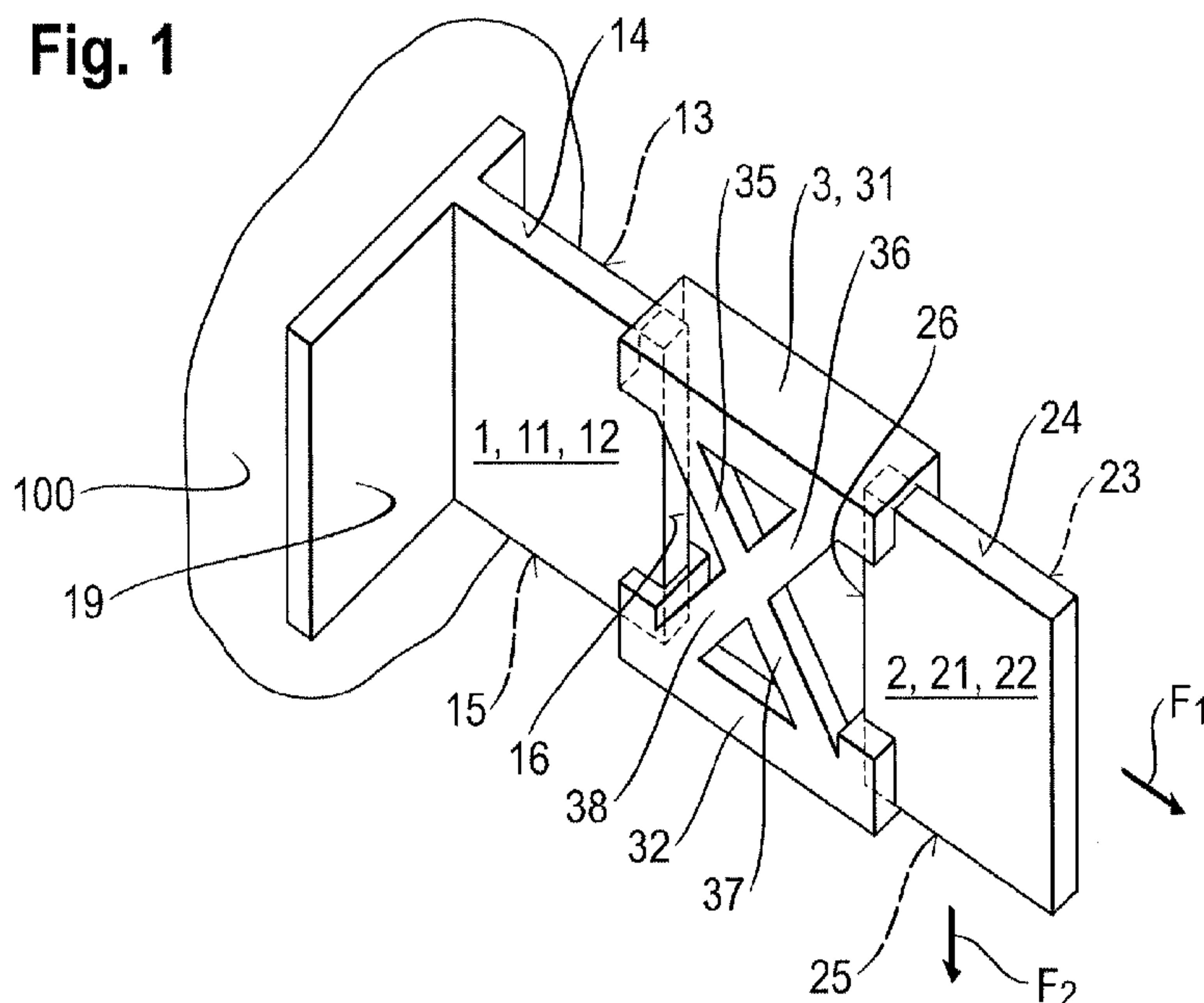

(57) Abstract: The invention relates to a bracket for connecting a façade to a building wall (100), comprising a metal wall part (1) for installing on the building wall, a metal façade part (2) for connecting to the façade, and a bridge part (3), which connects the façade part to the wall part, wherein the bridge part is composed of a plastic material and forms a heat barrier between the wall part and the façade part. According to the invention, the bridge part (3) is an injection-moulded part made of fibre-reinforced plastic and the bridge part is moulded over the wall part (1) and the façade part (2) in some areas of the wall part and of the façade part.

(57) Zusammenfassung: Die Erfindung betrifft eine Konsole zum Verbinden einer Fassade mit einer Gebäudewand (100), mit einem metallischen Wandteil (1) zur Montage an der Gebäudewand, einem metallischen Fassadenteil (2) zur Verbindung mit der Fassade, und einem Brückenteil (3), welches das Fassadenteil mit dem Wandteil verbindet, wobei das Brückenteil ein Kunststoffmaterial aufweist und eine Wärmesperre zwischen dem Wandteil und dem Fassadenteil bildet. Erfindungsgemäss ist

vorgesehen, dass das Brückenteil (3) ein Spritzgussteil aus faserverstärktem Kunststoff ist, und dass das Wandteil (1) und das Fassadenteil (2) vom Brückenteil bereichsweise umspritzt sind.

**WO 2014/108378 A1** 

---

- *vor Ablauf der für Änderungen der Ansprüche geltenden Frist; Veröffentlichung wird wiederholt, falls Änderungen eingehen (Regel 48 Absatz 2 Buchstabe h)*

## Heat-insulating console for joining a façade to a building wall

**[0001]** The invention relates to a console for joining a façade to a building wall. Such a console is fitted with a metal wall part for mounting on the building wall, a metal façade part for joining to the façade, and a bridge part that joins the façade part to the wall part, whereby the bridge part comprises a plastic material and forms a heat barrier between the wall part and the façade part.

**[0002]** A console of the generic type is disclosed in European patent application EP 2180115 A1. Such a console is provided with a bridge part that forms a heat barrier and thus counters undesired heat dissipation away from the wall via the console. Another console with a heat barrier is disclosed in German utility model DE 202004008376 U.

**[0003]** The objective of the invention is to put forward a console that is particularly cost-effective to produce and that is very reliable to install and use while, at the same time, having particularly good mechanical and thermal properties.

**[0004]** This objective is achieved according to the invention by means of a console having the features as described in preferred embodiments hereinbelow. According to an aspect a console for joining a façade to a building wall is provided. The console includes a metal wall part for mounting on the building wall, a metal façade part for joining to the façade, and a bridge part that joins the façade part to the wall part, whereby the bridge part includes a plastic material and forms a heat barrier between the wall part and the façade part, characterized in that the bridge part is an injection-molded part made of fiber-reinforced plastic, and in that the bridge part is injection-molded around the wall part and the façade part so as to encapsulate at least some portions of the wall part and the façade part.

**[0005]** A console according to the invention is characterized in that the bridge part is an injection-molded part made of fiber-reinforced plastic, and in that the bridge part is injection-

molded around the wall part and the façade part so as to at least partially encapsulate them, and preferably to only partially encapsulate them.

**[0006]** A first basic idea of the invention can be seen in the fact that the bridge part encapsulates the wall part and the façade part by means of injection-molding. In other words, the bridge part is joined to the wall part and to the façade part in that the latter are encapsulated by means of injection-molding, that is to say, during the production process, the material of the bridge part in the molten state is brought into contact with the wall part and the façade part, and the bridge part hardens while in contact with the wall part and the façade part. Since, according to the invention, the bridge part is in the form of an injection-molded encapsulation, an especially good mechanical bond can be achieved in the console that is also particularly reliable in terms of the forces and the temperature fluctuations in the façade area.

**[0007]** According to the invention, the bridge part constitutes a heat barrier, in other words, a thermal insulator. In particular, the material of the bridge part has a lower thermal conductivity than the material of the wall part and of the façade part. The bridge part joins the façade part to the wall part, and the façade part is mechanically affixed to the wall part by means of the bridge part. Preferably, the façade part, particularly when the façade has been dismantled, is joined to the wall part exclusively via the bridge part. In this manner, parallel heat flows can be prevented and an even better thermal insulation can be achieved. The façade part and/or the wall part are preferably joined directly to the bridge part, which can further simplify the production.

**[0008]** Moreover, the invention provides for the bridge part to be made of a fiber-reinforced plastic. As will be explained in detail below, such a plastic often displays thermal and mechanical properties that render it particularly well-suited for use in a console.

**[0009]** The façade preferably can be a rear-ventilated cladding for external walls, especially one according to standard DIN 18516-1, that is to say, the console is can be employed where a façade of a closed external wall is pre-installed. In particular, the invention can be used in combination with a layer of insulation material through which the console passes, whereby the

bridge part is preferably embedded into the insulation material layer. The façade preferably has a plurality of panels. The façade panels are preferably joined to the consoles according to the invention, particularly to the façade parts of the consoles, by means of a support profile structure which preferably can be made of metal. If a support profile structure is present, according to the invention, it can be seen as a constituent of the façade. In some embodiments of the invention, the façade part of the console has means to hold a support profile, such as a clamp.

**[0010]** It is especially preferable for the bridge part to have two support flanges which are at a distance from each other and which join the façade part and the wall part. In this manner, the forces that occur, especially wind forces, can be withstood very efficiently. In an embodiment, the two support flanges of the bridge part are injection-molded around the wall part and the façade part so as to at least partially encapsulate them. This translates into a very compact design. The two support flanges preferably run parallel to each other and/or horizontally.

**[0011]** It is likewise preferable for the two support flanges to be joined together by four bars in the bridge part arranged in a cross, especially in a diagonal cross. The intersection area of the four bars, in other words, the area where the four bars meet, is preferably situated between the two support flanges, especially in the center of the two support flanges. In particular, the injection point for the injection-molded bridge part can be at the intersection area of the bars. These bars can very easily and reliably stiffen the two support flanges particularly so that the force of the weight of the façade can be supported very reliably. Moreover, this can give rise to a particularly advantageous combination of the cross shape of the bars and the use of fiber-reinforced plastic in an injection-molding process. After all, the design of the bridge part as a diagonal cross, that is to say, in the form of an X, can bring about a specific orientation of the fibers. In particular, the fibers can be oriented in such a way that the preferential direction of the fibers in the bars is parallel to the individual bars. In this manner, the fibers are oriented primarily diagonally and particularly in the direction of the main flux of force when under load due to wind forces and/or the force of the weight.

[0012] According to the invention, the four bars can encompass four areas, namely, two crosswise areas that open towards the support flanges, and two opposing lengthwise areas that open towards the wall part or the façade part. The crosswise areas preferably have a smaller opening angle than the lengthwise areas.

[0013] It is especially preferred for the material thickness of the bridge part in at least one of the lengthwise areas, preferably in both lengthwise areas, at least in some portions thereof, but preferably everywhere, to be less than the material thickness of the bars. As an alternative or in addition, it is preferable for the material thickness of the bridge part in at least one of the crosswise areas, preferably in both crosswise areas, at least in some portions thereof, but preferably everywhere, to be less than the material thickness of the bars. These embodiments take into account the fact that the forces that occur can essentially already be absorbed by the connection flanges and the bars, so that the areas located between the bars can be configured so as to be relatively weak, without this entailing any major mechanical losses. Since the material in the areas can thus be relatively thin, the thermal insulating property of the bridge part can be further improved, without this entailing any major mechanical losses. According to the invention, the term “material thickness” refers to the thickness in a direction running perpendicular to the areas and/or perpendicular to the cross shape of the bars. In a properly mounted console, this direction can preferably be the horizontal direction. The four bars preferably have a constant material thickness and/or they all have the same material thickness gradient.

[0014] In particular, the material thickness in at least one of the lengthwise areas, preferably in both lengthwise areas, can be equal to zero, at least in some portions thereof. For this reason, it is especially preferred for at least one of the two lengthwise areas to have at least one opening. In some embodiments, both lengthwise areas have at least one opening. These openings can form, for example, air cushions that can even further reduce the heat conductivity of the bridge part. The term “opening” refers especially to a cutout that passes through the bridge part perpendicular to the areas and/or perpendicular to the cross shape of the bars.

**[0015]** It is likewise preferable for at least one of the crosswise areas to be closed, preferably completely, so that it does not have an opening. In particular, both crosswise areas can be closed, preferably completely. This can be advantageous with an eye towards the mechanical stability. With this embodiment, in certain cases, it is also possible to prevent or at least reduce the formation of seams in the area of the connection flange. Preferably, a higher percentage of the surface of the crosswise areas is closed than in the surface of the lengthwise areas.

**[0016]** It is also preferred for the wall part to have a plate element with two opposing flat sides and two opposing lengthwise sides, and/or for the façade part to have a plate element which has two opposing flat sides and two opposing lengthwise sides and which runs preferably coplanar to the plate element of the wall part. This can be advantageous in that it can facilitate production. In particular, the wall part and/or the façade part can be configured in the form of an extruded part. The wall part can have, for instance, a mounting plate that is placed on the wall from which the plate element of the wall part protrudes, preferably at a right angle. The façade part can have a holding clamp that projects from the plate element of the façade part, whereby a support profile of the support profile structure of the façade can be clamped between the holding clamp and the plate element of the façade part. Preferably, an end face of the façade part faces an end face of the wall part. In a properly mounted console, the bars and the two plates advantageously run in at least one vertical plane, preferably in precisely one vertical plane.

**[0017]** In particular, it can be provided that the opposing lengthwise sides of the wall part and/or the opposing lengthwise sides of the façade part are enclosed in some areas by the bridge part, whereby the bridge part preferably creates a snug fit for the opposing lengthwise sides of the wall part or for the opposing lengthwise sides of the façade part. Thanks to this snug fit on the lengthwise side, the force of the weight of the façade can be transferred very effectively.

**[0018]** According to the invention, the fiber-reinforced plastic has a matrix and a plurality of fibers. The matrix can especially be a thermoplastic, for instance, a polyamide, preferably polyamide 6.6.

**[0019]** Another preferred configuration of the invention lies in the fact that the coefficient of thermal expansion of the matrix is greater, and the coefficient of thermal expansion of the fibers is smaller, than the coefficient of thermal expansion of the two plate elements. This can again yield an advantageous interaction with the geometry according to the invention since, due to the fact that the preferential direction of the fibers in the bars advantageously runs parallel to each individual bar, the coefficient of thermal expansion of the bars as seen along the bars is between the coefficient of thermal expansion of the fibers and the coefficient of thermal expansion of the plastic matrix. Therefore, in this preferred configuration, the thermal expansion of the bridge part can be adapted to the thermal expansion of the adjacent metal wall part and/or to that of the adjacent metal façade part, so that an undesired thermal stress at the transition from the bridge part to the wall part, or at the transition from the bridge part to the façade part, can be avoided. Owing to the fiber orientation along the diagonals, the thermal expansion of the plastic can be made to approximate the thermal expansion of the adjacent metal.

**[0020]** Advantageously, it can be provided that the four bars, preferably the four bars and the two support flanges, especially preferably the entire bridge part, are mirror symmetrical along one plane of symmetry, and preferably along two planes of symmetry. A plane of symmetry can preferably be perpendicular to the cross shape of the bars and can run through the wall part and the façade part. In a properly mounted console, this plane of symmetry is preferably in the horizontal. A symmetrical design can be advantageous in terms of the mechanical properties and/or the fiber orientation. In particular, the symmetrical configuration can make it possible to install the console in several orientations at identical load values, which also simplifies the use.

**[0021]** Another advantageous refinement of the invention is that the injection point of the bridge part is in at least one plane of symmetry of the bridge part. As a result, the fiber orientation and/or the mechanical properties can be further improved.

**[0022]** It is particularly preferred for the bridge part to have precisely one injection point, which simplifies the production.

**[0023]** Preferably, it can be provided that an injection point of the bridge part is situated in an intersection area of the four bars, in other words, preferably in the center of the diagonals. Owing to the geometry according to the invention and to the selection of an injection point in a plane of symmetry and/or in the intersection area of the bars, the fibers in the bridge part can be systematically oriented, as a result of which the following is attained:

- a) The thermal expansion of the plastic molded part approximates the thermal expansion of the metal parts that are touching each other. This minimizes mechanical stresses in the component when temperatures fluctuate.
- b) The main flux of force runs in the fiber direction, thus utilizing the greater material strength in the fiber direction.

**[0024]** Preferably, the wall part and/or the façade part has/have a ribbed structure that is encapsulated by the bridge part by means of injection-molding. This permits a better transfer of force between the individual parts. In particular, the ribbed structure can be provided on the plate element of the wall part or of the façade part. Each ribbed structure suitably has a plurality of ribs that run on at least one flat side, preferably on both flat sides, of the corresponding plate element and/or parallel to the end face of the corresponding plate element.

**[0025]** It is likewise preferred for the bridge part to be configured as a single piece. This reduces the production work and improves the mechanical stability even further. In particular, the bars and the connection flanges can be configured as a single piece.

**[0026]** The invention will be explained in greater detail on the basis of preferred embodiments that are schematically depicted in the accompanying figures, whereby individual features of the embodiments presented below can be implemented in conjunction with the invention either individually or in any desired combination. The figures show the following schematically:

Figure 1: a first embodiment of a console according to the invention, in a perspective view;

Figure 2: a detailed view of the console according to Figure 1, from the side; and

Figure 3: a second embodiment of a console according to the invention, in a perspective view.

**[0027]** Identically functioning elements are designated by the same reference numerals in the figures.

**[0028]** A first embodiment of a console according to the invention is shown in Figures 1 and 2. The console has a wall part 1 that is mounted on a building wall 100, a façade part 2 that is mounted on a façade (not shown here), as well as a bridge part 3 that mechanically secures the façade part 2 to the wall part 1, thereby creating a heat barrier between the wall part 1 and the façade part 2.

**[0029]** The wall part 1 has a mounting plate 19 that lies flat on the building wall 100, and a plate element 11 which projects from the mounting plate 19 at a right angle and on which the bridge part 3 is arranged. The façade part 2 likewise has a plate element 21. The plate element 21 of the façade part 2 is supported by the bridge part 3. In this context, the plate element 21 of the façade part 2 runs parallel – and coplanar in the embodiment shown – to the plate element 11 of the wall part 1.

**[0030]** The plate element 11 of the wall part 1 has two opposing flat sides 12 and 13, two opposing narrow lengthwise sides 14 and 15 as well as a narrow, free end face 16. The plate element 21 of the façade part 2 likewise has two opposing flat sides 22 and 23, two opposing narrow lengthwise sides 24 and 25 as well as a narrow, free end face 26. The free end face 26 of the façade part 2 and the free end face 16 of the wall part 1 face each other as well as the bridge part 3.

**[0031]** When the flat sides 12, 13, 22 and 23 and/or the end faces 16 and 26 have been properly installed, as a rule, they run vertically, that is to say, the lengthwise sides 14 and 24 are

above the lengthwise sides 15 and 25, respectively. Fundamentally, however, installation in which the flat sides 12, 13, 22 and 23 run horizontally or obliquely is also possible.

**[0032]** The bridge part 3 is an injection-molded part made of fiber-reinforced plastic. It has a first, preferably upper, support flange 31, and a second, preferably lower, support flange 32. The two support flanges 31, 32 run at a distance from each other, preferably in the horizontal direction, each from the wall part 1 to the façade part 2, and they join the façade part 2 to the wall part 1. In this context, the two support flanges 31 and 32 of the bridge part 3 are injection-molded around the wall part 1 and the façade part 2 so as to encapsulate them. Each one of the two support flanges 31 and 32 is in contact with the two flat sides 12 and 13 of the wall part 1 and with the two flat sides 22 and 23 of the façade part 2. Preferably, the first support flange 31 can also be in contact with the lengthwise side 14 of the wall part 1 and the lengthwise side 24 of the façade part 2, and/or the second support flange 32 can be in contact with the lengthwise side 15 of the wall part 1 and with the lengthwise side 25 of the façade part 2.

**[0033]** The bridge part 3 also has four bars 35, 36, 37, 38 which are joined together by means of the two support flanges 31, 32 and which stiffen the two support flanges 31 and 32 with respect to each other. The four bars 35, 36, 37, 38 form a cross shape and run in a parallel, preferably coplanar, plane to the plate elements 11 and/or 21, whereby the intersection area of the four bars 35, 36, 37, 38, in other words, the area where the four bars 35, 36, 37, 38 meet, is situated in the center between the two support flanges 31 and 32. The four bars 35, 36, 37, 38 and the two support flanges 31 and 32 are configured so as to be mirror-symmetrical along a plane that is perpendicular to the cross shape of the four bars 35, 36, 37, 38 and that runs between the two support flanges 31 and 32 (in Figure 2, this plane of symmetry is perpendicular to the drawing plane and runs from left to right). The four bars 35, 36, 37, 38 and the two support flanges 31 and 32 are also configured so as to be mirror-symmetrical along another plane of symmetry which is perpendicular to the cross shape of the four bars 35, 36, 37, 38 and which intersects the two support flanges 31 and 32 (in Figure 2, this second plane of symmetry is perpendicular to the drawing plane and runs from top to bottom).

**[0034]** The injection point 40 of the bridge part, in other words, the area where the fiber-reinforced plastic material was fed into the mold during the injection-molding process, is located in the intersection area of the four bars 35, 36, 37, 38. In the four bars 35, 36, 37, 38, the preferential direction of the fibers of the fiber-reinforced plastic material is approximately parallel to the corresponding bar, as indicated by arrows in Figure 2.

**[0035]** In the plane of their cross shape, the four bars 35, 36, 37, 38 enclose four areas 41, 42, 43, 44, namely, two diametrically opposing crosswise areas 41 and 42 that, starting from the intersection area of the bars 35, 36, 37, 38, open towards the support flange 31 or the support flange 32, and two diametrically opposing lengthwise areas 43 and 44 that, starting from the intersection area of the bars 35, 36, 37, 38, open towards the wall part 1 or the façade part 2. The crosswise areas 41 and 42 have a smaller opening angle than the lengthwise areas 43 and 44.

**[0036]** In the embodiment shown, the areas 41, 42, 43, 44 are not filled with plastic material and they each form an opening. However, the areas 41, 42, 43 and/or 44 can also be filled with plastic material. The following then preferably applies to the material thicknesses:

$0 \leq a \leq b \leq c$ , wherein

- a stands for the material thickness in the individual lengthwise area(s) 43 and/or 44,
- b stands for the material thickness in the individual crosswise area(s) 41 and/or 42, and
- c stands for the material thickness in at least one of the bars 35, 36, 37, 38, preferably in all of the bars.

**[0037]** This relationship is not limited to the embodiment shown in Figures 1 and 2, but rather, can also be employed for other geometries according to the invention.

**[0038]** The console shown in Figures 1 and 2 especially can withstand the force F1, for example, the wind force on the façade and the force F2, for instance, the force of the weight of the façade.

**[0039]** Another embodiment of the console according to the invention is shown in Figure 3. The embodiment of Figure 3 implements a number of features of the embodiment from Figures 1 and 2 in an analogous manner, so that the above-mentioned description can be employed analogously and only the differences will be elaborated upon below.

**[0040]** The support flanges 31 and 32 in the embodiment of Figure 3 are structured. They have struts and depressions located between the struts.

**[0041]** The crosswise areas 41 and 42 in the embodiment of Figure 3 are completely filled. In the lengthwise areas 43 and 44, there are struts 53 and 54 that adjoin the intersection area of the bars 35, 36, 37, 38 and whose material is thinner than that of the bars 35, 36, 37, 38. Moreover, the lengthwise areas 43 and 44 have openings 45 and 46. The strut 53 is located between the opening 45 and the intersection area, while the strut 54 is located between the opening 46 and the intersection area. The surface area of the strut 53 is smaller than the adjacent opening 45, and the surface area of the strut 54 is smaller than the adjacent opening 46.

**[0042]** In the embodiment of Figure 3, the plate elements 11 and 12 of the wall part 1 and the façade part 2, respectively, have a ribbed structure 18 and 28, on which the bridge part 3 is joined to the wall part 1 or to the façade part 2. The mounting plate 19 of the wall part 1 has a hole through which an anchor bolt can be inserted in order to anchor the mounting plate 19 to the building wall. The façade part 2 of Figure 3 has a holding clamp 70 that is arranged on the plate element 21 of the façade part 2. During the installation procedure, a support profile 101 – only shown as a rough schematic in the form of dashed lines – of the support profile structure of the façade can be held temporarily by clamping between the holding clamp 70 and the plate element 21. In the plate element 21 of the façade part 2, there are openings that allow the temporarily clamped support profile 101 to be permanently screwed to the façade part 2.

## CLAIMS

1. A console for joining a façade to a building wall (100), comprising a metal wall part (1) for mounting on the building wall (100), a metal façade part (2) for joining to the façade, and  
a bridge part (3) that joins the façade part (2) to the wall part (1), whereby the bridge part (3) comprises a plastic material and forms a heat barrier between the wall part (1) and the façade part (2), characterized in that the bridge part (3) is an injection-molded part made of fiber-reinforced plastic, and in that the bridge part (3) is injection-molded around the wall part (1) and the façade part (2) so as to encapsulate at least some portions of the wall part and the façade part.
2. The console according to claim 1, characterized in that the bridge part (3) has two support flanges (31, 32) which are at a distance from each other and which join the façade part (2) and the wall part (1), and in that the two support flanges (31, 32) of the bridge part (3) are injection-molded around the wall part (1) and the façade part (2) so as to encapsulate the at least some portions of the wall part and the façade part.
3. The console according to claim 2, characterized in that the two support flanges (31, 32) are joined together by means of four bars (35, 36, 37, 38) arranged in a diagonal cross in the bridge part (3).
4. The console according to claim 3, characterized in that the four bars (35, 36, 37, 38) encompass four areas (41, 42, 43, 44), including two crosswise areas (41, 42) that open towards the support flanges (31, 32), and two lengthwise areas (43, 44) that open towards the wall part (1) or the façade part (2), whereby a material thickness of the bridge part (3) in the lengthwise areas (43, 44) is less than a material thickness of the bars (35, 36, 37, 38), or the material thickness of the bridge part (3) in the crosswise areas (42, 42) is less than the material thickness of the bars (35, 36, 37, 38).

5. The console according to claim 4, characterized in that the lengthwise areas (43, 44) have at least one opening (45, 46), and in that the crosswise areas (41, 42) are at least partially closed.
6. The console according to one of claims 3 to 5, characterized in that a fiber orientation of the fiber-reinforced plastic in the bars (35, 36, 37, 38) is parallel to the individual bars (35, 36, 37, 38).
7. The console according to any one of claims 1 to 6, characterized in that the wall part (1) has a plate element(11) with two opposing flat sides (12, 13) and two opposing lengthwise sides (14, 15), and in that the façade part (2) has a plate element (21) which has two opposing flat sides (22, 23) and two opposing lengthwise sides (24, 25) and which runs coplanar to the plate element (11) of the wall part (1), whereby the opposing lengthwise sides (14, 15) of the wall part (1) or the opposing lengthwise sides (24, 25) of the façade part (2) are at least partially enclosed by the bridge part (3), whereby the bridge part (3) creates a snug fit for the opposing lengthwise sides (14, 15) of the wall part (1) or for the opposing lengthwise sides (24, 25) of the façade part (2).
8. The console according to claim 7, characterized in that the fiber-reinforced plastic has a matrix and a plurality of fibers, whereby a coefficient of thermal expansion of the matrix is greater than a coefficient of thermal expansion of the plate elements of the wall part and the façade part (11, 21), and a coefficient of thermal expansion of the fibers is smaller than the coefficient of thermal expansion of the two plate elements (11, 21).
9. The console according to one of claims 3 to 6, characterized in that an injection point (40) of the bridge part (3) is situated in an intersection area of the four bars (35, 36, 37, 38).

10. The console according to any one of claims 1 to 9, characterized in that the wall part (1) and the façade part (2) have a ribbed structure (18, 28, respectively) that is encapsulated by the bridge part (3) by means of injection-molding
  
11. The console according to any one of claims 1 to 10, characterized in that the bridge part (3) is configured as a single piece.

Fig. 1

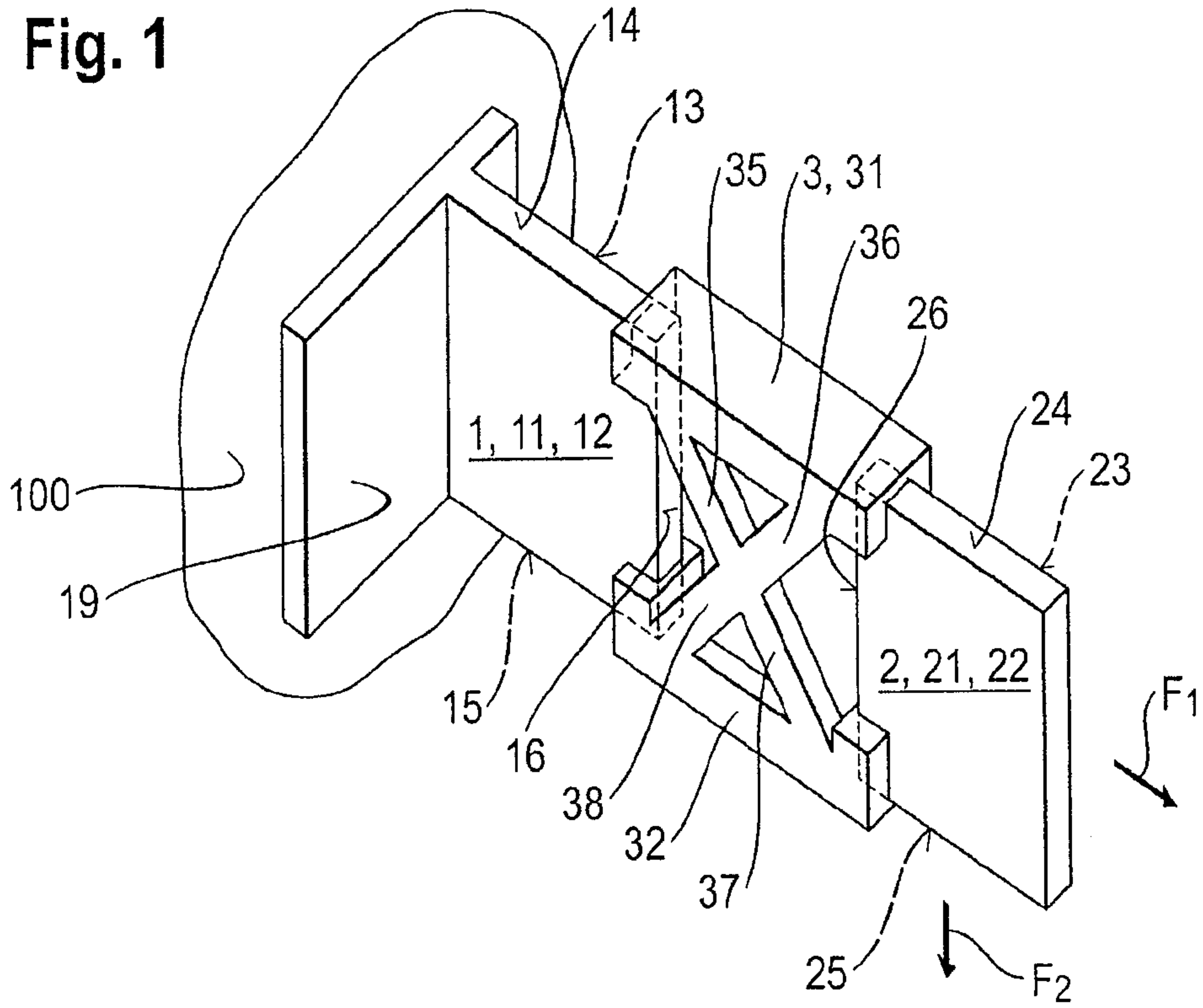
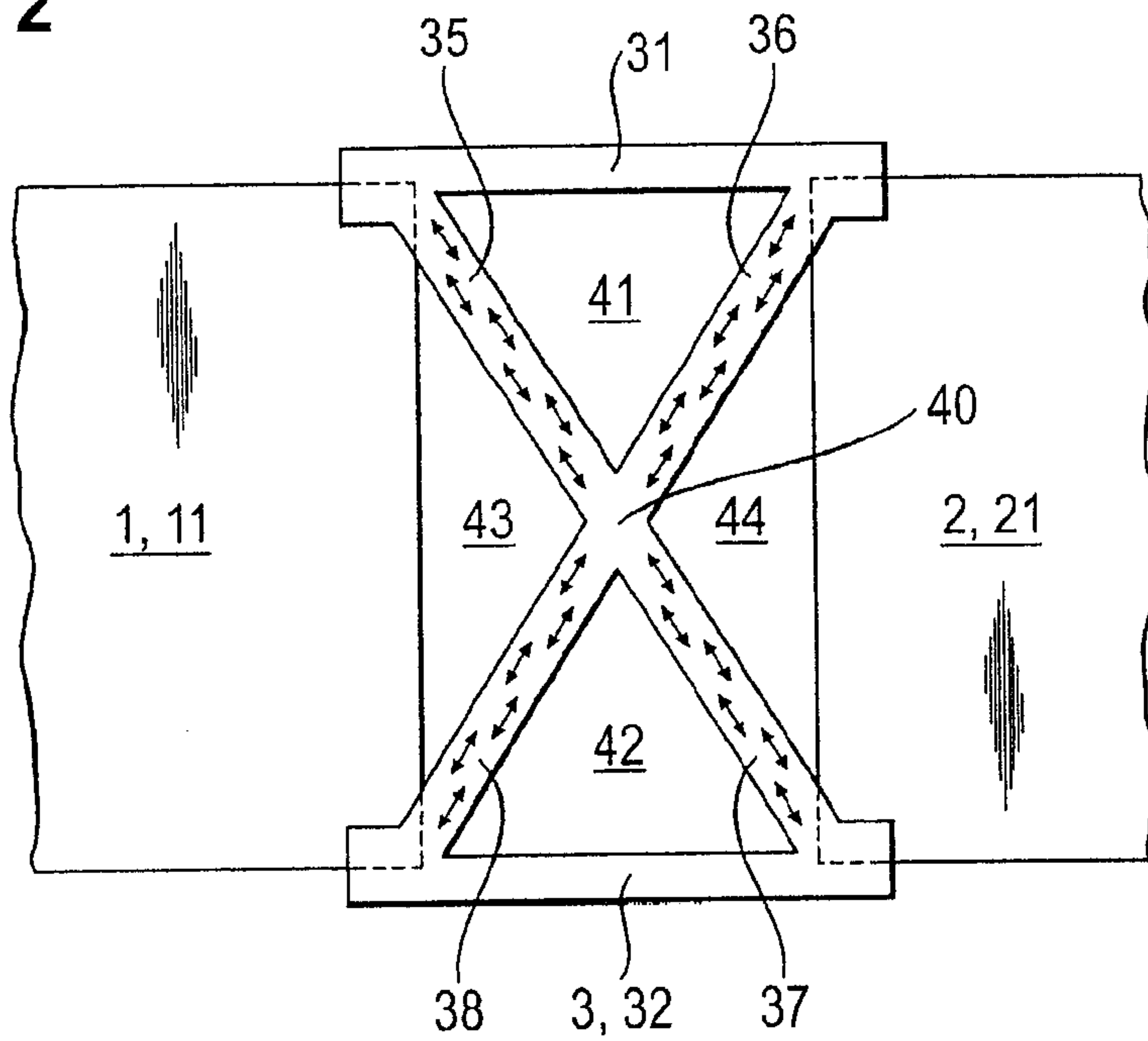

Fig. 2



ERSATZBLATT (REGEL 26)

Fig. 3

