

J. CUMMING.
MACHINE FOR LENGTHENING BOILER FLUES.

No. 526,688.

Patented Oct. 2, 1894.

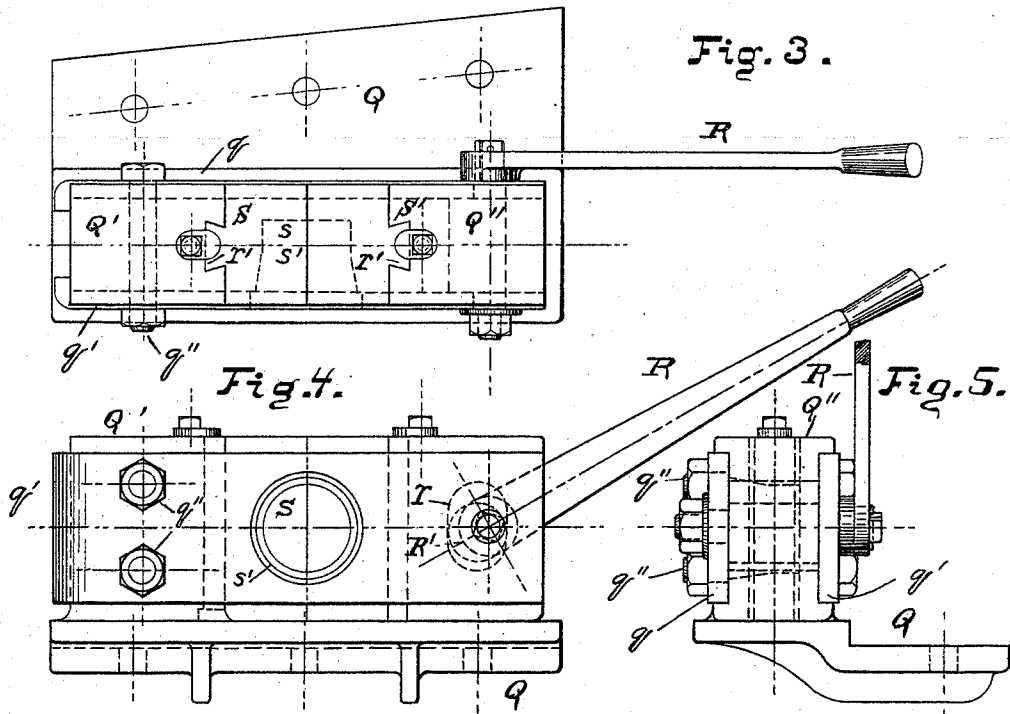

Fig. 6.

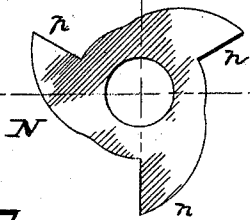

Fig. 7.

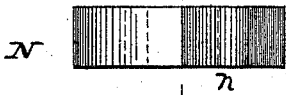

Fig. 9.

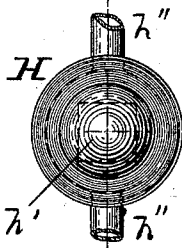
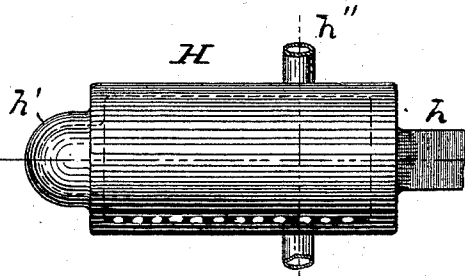

Fig. 8.



Witnesses:

Wm. H. Dapp.
Al Stark.

Inventor.

James Cumming.
By Michael Stark.
Attorney.

J. CUMMING.

MACHINE FOR LENGTHENING BOILER FLUES.

No. 526,688.

Patented Oct. 2, 1894.

Fig 10.

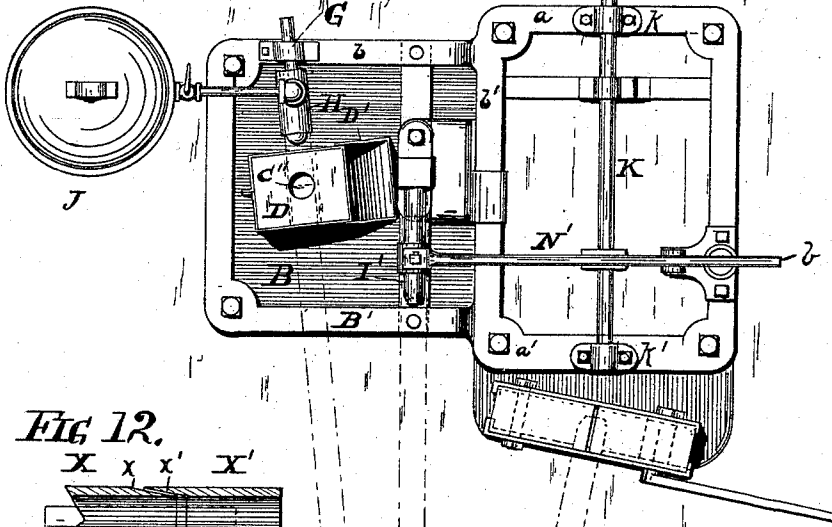

Fig 12.

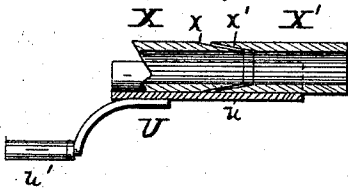

Fig 11.

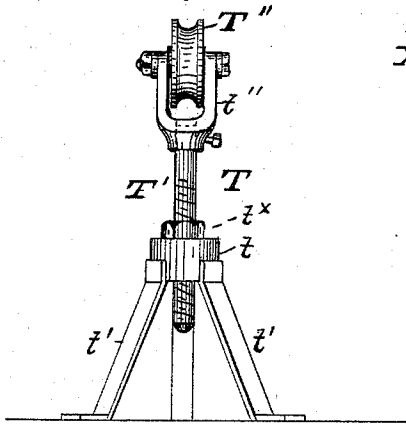
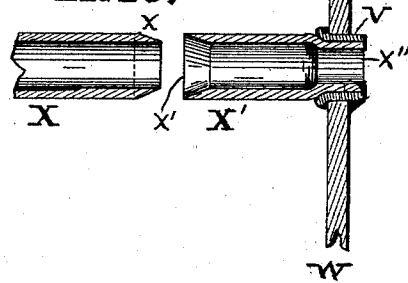

Fig 13.



Witnesses:

Wm H. Dopp
Ch Stark

Inventor :

James Cumming
 by *Michael J. Starr*
 Attorney

UNITED STATES PATENT OFFICE.

JAMES CUMMING, OF BUFFALO, NEW YORK.

MACHINE FOR LENGTHENING BOILER-FLUES.

SPECIFICATION forming part of Letters Patent No. 526,688, dated October 2, 1894.

Application filed January 22, 1894. Serial No. 497,680. (No model.)

To all whom it may concern:

Be it known that I, JAMES CUMMING, of Buffalo, in the county of Erie and State of New York, have invented certain new and useful
5 Improvements in Machines for Lengthening Boiler-Flues; and I do hereby declare that the following description of my said invention, taken in connection with the accompanying sheets of drawings, forms a full, clear, and exact specification, which will enable others
10 skilled in the art to which it appertains to make and use the same.

This invention has general reference to improvements in machines for lengthening
15 boiler flues; and it consists, essentially, in the novel and peculiar combination of parts, and details of construction, as hereinafter first fully set forth and described and then pointed out in the claims.

20 In the drawings already referred to, which serve to illustrate my said invention more fully, Figure 1 is a plan of my improved machine for lengthening boiler flues. Fig. 2 is a front elevation of the same. Fig. 3 is a plan
25 of the device for contracting the end of the flue. Fig. 4 is a front, and Fig. 5 a side elevation of the same. Fig. 6 is a side, and Fig. 7 a top view of the star wheel. Fig. 8 is a plan, and Fig. 9 an end elevation of the holder.
30 Fig. 10 is a general plan view of the entire apparatus showing the respective location of the parts. Fig. 11 is an elevation of the standard supporting the flue while being operated upon, and Fig. 12 is a side view of
35 the end-piece carrier. Fig. 13 is a sectional view of a portion of the boiler flue and the end-piece.

Like parts are designated by corresponding letters of reference in all the figures.

40 The object of this invention is the production of an efficient machine or device for lengthening boiler flues, and especially the flues of locomotive boilers, which have to be removed from the boilers from time to time
45 to clean the same as well as the boiler shell. This removal from the boiler necessitates the cutting out of the flues, which thereby are made several inches too short for reuse. A piece of the same size of flue is then welded
50 onto the same to restore it to its full length, and to readily and cheaply accomplish this object is the purpose of my invention. Here-

tofore those portions which were welded onto the flue, and which I shall designate end-pieces, had to be from six to eight inches in
55 length because no device existed to my knowledge which would allow the use of shorter end-pieces to be welded onto the flue. By the construction of the device hereinafter to be
60 described, I am enabled to weld end-pieces of but four inches or less in length, thus saving the cost of several inches on every flue to be lengthened, and amounting to quite a large
65 sum of money to railway companies having many locomotives in use. To accomplish this object, I construct my machine for welding the ends of boiler flues in the following
manner.

A, in the drawings represents a base plate, and B the top plate of a frame, both plates
70 being separated by a series of pillars or supporting bars C, as clearly shown in Fig. 2. The top plate B of this frame is of peculiar design, it consisting of an oblong main portion, to one side of which is joined a further
75 oblong portion, the latter being depressed below the plane of the former, as clearly shown in Fig. 2, this depressed portion being designated by the reference letter B'. Upon
80 this depressed portion B' I locate a furnace D, constructed substantially as set forth in Letters Patent of the United States granted to me on the 21st day of May, 1889, No. 403,520,
85 and consisting, essentially, of a fire-brick structure of cubical form and having horizontally a circular passage *d*, for the reception of the boiler flue and the end-piece to be
welded thereto, and a vertical passage *d'* containing the fuel, and a side passage, *d''*,
90 through which the fuel, (coke, anthracite coal or the like,) is introduced to the furnace from the hopper D'. This furnace is placed upon the hearth E below which is located the tuyere and grate F.

Upon the back member *b* of the depressed
95 portion of the top plate B' is located a standard G, secured thereto by bolts *g*, and having at its upper end and horizontally through it, an angular passage for the reception of the
100 angular stem *h* of a holder H, shown in detail in Fig. 8, the central axis of which is in line with the circular horizontal passage *d* in the furnace D. This holder H consists of a cylindrical shell having at one end the an-

gular stem *h* already mentioned, and at the other end a smaller hollow protuberance *h'*, the diameter of which is somewhat smaller than the inner diameter of the boiler flue to be lengthened, and the object of which is to support the end-piece *X'* while in the furnace, while the purpose of the holder is to serve as an abutment, as will hereinafter more fully appear. This holder has two nozzles *h''*, one being upwardly, and the other downwardly projecting and the latter serving as an inlet and the former as an outlet for a stream of water from a reservoir *J*, with which said nozzles are connected by the pipes, hose or similar conductors *j j'*, a stop cock *j''* being located in the supply pipe *j* to regulate the flow of water from said reservoir to the holder *H*. The object of this water-current is to keep the holder cool when being subjected to the heat of the furnace as it will when short end-pieces are being welded onto the flue and the holder occupying a position partly within the rear end of the horizontal passage *d*.

At a suitable distance from the member *b'* of the top plate *B*, and running parallel therewith is a cross bar *b''*, upon which is secured a stake-holder *I*, consisting of a base-plate *i*, having an upright socket *i'*, within which is inserted an L-shaped horn *I'*, being a cylindrical mandrel provided with a shank *i''*, Fig. 2, on its end fitting the socket *i'* and suitably held therein by a set screw or other proper means *i^x*. This horn serves the purpose of a stake upon which the boiler flue is swaged after welding as hereinafter to be referred to.

Upon the members *a a'* of the top frame are provided bearings *k k'*, for the shaft *K* to rotate in, said shaft having a driving pulley *K'*, by means of which it is rotated from a suitable motor, and a balance wheel *L*, to equalize its motion. This shaft is also provided with a friction clutch *M*, which engages and disengages the shaft *K* from the driving pulley *K'* and, therefore, allows of the instantaneous starting and stopping of said shaft *K*. This friction clutch is operated by a treadle *m*, and suitable connecting rod *m'* in the well-known manner. Upon the shaft *K* there is further affixed a star wheel *N*, shown in detail in Figs. 6 and 7, and engaging with its teeth *n* the incline *n'* on an arm *N'*, which said arm is pivoted in an upright *N''* and has a short extension *n''*, bearing upon a spiral spring *O*. On the opposite end of this arm, and directly opposite the horn *I'* there is removably fixed a swage *O'*, which fits the respective tube to be welded, in conjunction with a properly-sized horn *I'*. This lever *N'* is actuated by the star wheel so as to strike rapid blows with the swage *O'*, the mechanism being very simple and its operation readily understood.

To somewhat deaden the blow of the striking swage, there is, in a yoke *P* secured upon the member *b'* of the top plate, an elastic

cushion *P*, as shown in Fig. 2, said yoke also serving as a guide for the arm *N'*.

The stake holder *I* is adjustably secured upon the member *b'* and cross bar *b''* by means of a series of holes *c*, in said member *b'*, through which the bolt *c'* may be passed and thereby the stake holder *I* moved farther away from, or nearer to, the swage *O'*. The object of this construction is to enable me to weld end-pieces of different length to the boiler flue *X* and to bring the extreme end of such pieces to bear against the shank *i''* of the horn *I'*, which thus acts as a gage and locates the joint in the flue and end-piece properly upon the horn under the swage *O'*.

To the forward member *a'* of the top plate *B* is attached a squeezing device, consisting of any suitable mechanism, motor or otherwise, having jaws of suitable shape to reduce the extremity of the boiler flue to proper size, and in this present instance I have shown in Figs. 3, 4 and 5 one such mechanism consisting of a base plate *Q*, having an upright *Q'*, two cheeks *q q'*, secured to the upright *Q'* by the bolts *q''*, a movable upright *Q''*, operated by a lever *R*, and eccentric *R'* engaging a slotted aperture *r*, in the movable upright *Q''*. The vertical and oppositely-located faces of these uprights are provided with dove-tail grooves *r'*, receiving similarly-shaped tenons on removable jaws *S S'*, which jaws have semicircular recesses *s*, in their faces forming together a circular recess of a diameter suitable for the reduced extreme end *x''* of the boiler flue *X*. This recess *s* has a tapering portion *s'*, while the front cheek *q'* has a circular hole *s''*, of sufficient diameter to admit the end of the boiler flue when of full size. This mechanism for reducing the extreme end of the boiler flue is very simple and inexpensive, but I may substitute therefor other mechanism, such as a steam or compressed air motor, hammer, &c., having jaws *S S'* as described, without departing from the nature of my said invention.

The boiler flue *X*, when being operated upon in my machine is carried upon a standard *T*, Fig. 11, consisting of a nut *t*, to which legs or supports *t'* are properly fastened, a screw-spindle *T'*, having at its upper end and loosely revolving thereon, a yoke *t''* carrying between its arms or fork a sheave *T'''*, a lock-nut *t^x* being provided to lock the spindle *T'* in any desired height.

I shall now proceed to describe the operation of this device for welding the end-pieces to boiler flues, but will first state that to joint the end-piece to the flue, the latter is first tapered or scarfed to a sharp edge, as shown in Figs. 12 and 13 at *x*, and the end-piece oppositely tapered at *x'*, this portion of the work being done with reamers or in a lathe, so as to have perfectly clean and bare metal surfaces. Now the end-piece *X'* is placed upon a carrier *U*, shown in Fig. 12 and consisting of a scoop-shaped holder *u*, having a

handle w' , and introduced into the horizontal passage d of the furnace D, and the flue X immediately pushed after the end-piece until the latter rests with its extreme end upon the protuberance h' and abuts against the holder H. This holder is so adjusted as to bring the joint of the tube directly into the center of the vertical passage of the furnace where the same rapidly heated to a welding heat, which may be observed through the peep-hole C'' , being in reality the upper portion of the vertical passage. Now the end of the boiler flue X which is farthest away from the furnace is lightly struck a number of blows in quick succession, by a helper, which will force the tube into the end-piece, (which abuts against the holder and is prevented from receding,) and the weld practically completed, it being understood that proper flux, such as borax is used in the operation. The boiler flue X with its end-piece X' now welded to it is rapidly removed from the furnace and placed upon the horn I' when the operator, stepping upon the treadle m , starts the swage and by a rapid succession of blows reduces the place where the weld has taken place, and which has been increased in diameter and thickness by the upsetting operation in the furnace, to the original size of the flue. The extreme end of the now lengthened flue is still red hot and, to contract it at its extreme end x'' to the proper diameter to fit the usual ferule V which is employed to secure the flue within the copper fire-box flue-sheet W, as shown in Fig. 13, it is now introduced into the squeezer shown in Figs. 3 and 4, where the tube enters the taper portion s in the jaws $S S'$ and by a succession of movements up and down of the lever R causes the said jaws $S S'$ to reduce the said extreme end x'' of said flue to the desired diameter. Rubbing the end of the flue where the weld has been effected over a scraper Z, shown in Fig. 2 completes the operation, and it may here be stated that an experienced operator with one helper will weld not less than fifty flues in an hour, a fact that has never before been accomplished as far as I am aware, and which reduces the cost of lengthening boiler flues to a mere trifle.

It will be observed by an examination of Fig. 10, that the furnace D, horn I' and the squeezing mechanism for the extreme end of the flue are radially arranged, their common center being in the standard T, whereby it is possible to do all the operations upon the flue in that rapid succession which is essential to the successful performance of the task to be accomplished.

Heretofore it has been considered impossible to weld onto the end of a boiler flue an end-piece of less than six inches in length because the end-piece could not be properly held in position while in the furnace, and this resulted in a waste of tubes and a loss of time in cutting them off to proper length after lengthening. By the introduction of

the adjustable holder H and by making it hollow and passing a current of water through it, I have accomplished the feat of welding end-pieces of only three or four inches in length to the flue, because I am enabled to move the holder H horizontally so that it may pass into the rear end of the horizontal passage d of the furnace D a sufficient distance to enable the shortest end-piece to abut against it when the joint to be welded is in the center of the furnace, the current of water passing through the holder keeping it low enough in temperature to prevent it from burning, but not sufficiently so as to chill the shorter end piece while being welded in the furnace thereby saving several inches of length of tubing on each boiler flue which, where about three hundred boiler flues from a single locomotive boiler are to be lengthened forms quite a large item of saving of stock, not to mention the additional saving in time, and other obvious advantages gained by my method of procedure.

Having thus fully described my invention, I claim as new and desire to secure to me by Letters Patent of the United States—

1. An organized machine for lengthening boiler flues, consisting, essentially, of a top plate having a depressed portion, a furnace located upon this depressed portion, a horizontal passage in said furnace to receive the flue and end piece to be welded together, an adjustable holder and abutment in the rear of said furnace and having its center line coinciding with that of the horizontal passage described, an adjustable horn secured to a stake holder fastened to a cross-bar of the depressed portion of the top plate, a swage operated by suitable mechanism, and a squeezer secured to the top plate, the said furnace, horn and squeezer being radially arranged and having their common center in the tripod located a suitable distance from the machine, as and for the object set forth and described.

2. In a machine for lengthening boiler flues, the combination, with the furnace, of a hollow holder having a protuberance as described, the reservoir and pipes connecting the reservoir with the holder, as stated.

3. In a machine for lengthening tubes, the combination, with the top plate, of a furnace having a horizontal passage as described, of the abutment consisting of a holder adjustably secured to a standard fastened upon a portion of the top plate and adapted to enter the rear end of the said horizontal passage in said furnace, as and for the object set forth.

4. In a machine for lengthening tubes, the combination, with the top plate having the depressed portion, of a furnace located thereon, an adjustable horn secured to a stake holder fastened to the cross bar as described, the bearings in the front and rear members of said top plate, a shaft rotating in said bearings, clutch mechanism upon said shaft and

a treadle device for starting and stopping said clutch mechanism, an arm pivoted in an upright fastened to the top plate and carrying on one end a swage and acting with its other
5 end upon a coil spring, said arm being actuated by a star wheel upon said shaft, as and for the object stated.

5. In a machine for lengthening tubes, the combination, with the top plate, of the furnace, the horn and swage, and a mechanically-operated squeezer for contracting the
10 end of said tube immediately after having

been lengthened, said squeezer having a fixed plate provided with a passage fitting the tube to be contracted and movable jaws provided
15 with semi-circular recesses having a tapering portion, as and for the object set forth.

In testimony that I claim the foregoing as my invention I have hereunto set my hand in the presence of two subscribing witnesses.

JAMES CUMMING.

Attest:

MICHAEL J. STARK,

WM. O. STARK.