

929,662.

Patented Aug. 3, 1909.

3 SHEETS—SHEET 1.

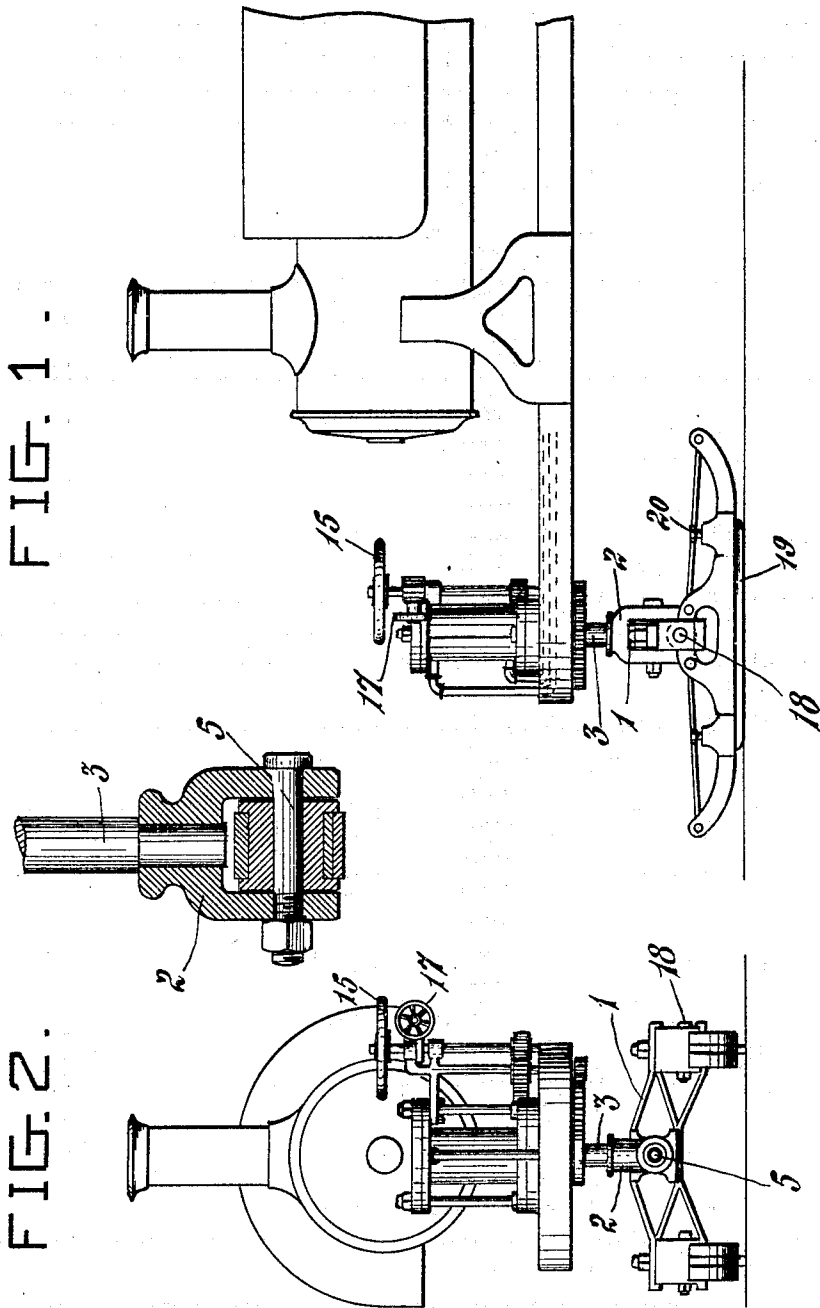

FIG. 1.

FIG. 6.

FIG. 2.

Witnesses:
C. Jacquemont
S. H. Gannon

Alexander Dunbar,
Inventor,
By *Marion Marion*
Attorneys

A. DUNBAR.
 LOGGING ENGINE.
 APPLICATION FILED DEC. 7, 1908.

929,662.

Patented Aug. 3, 1909.

3 SHEETS—SHEET 2.

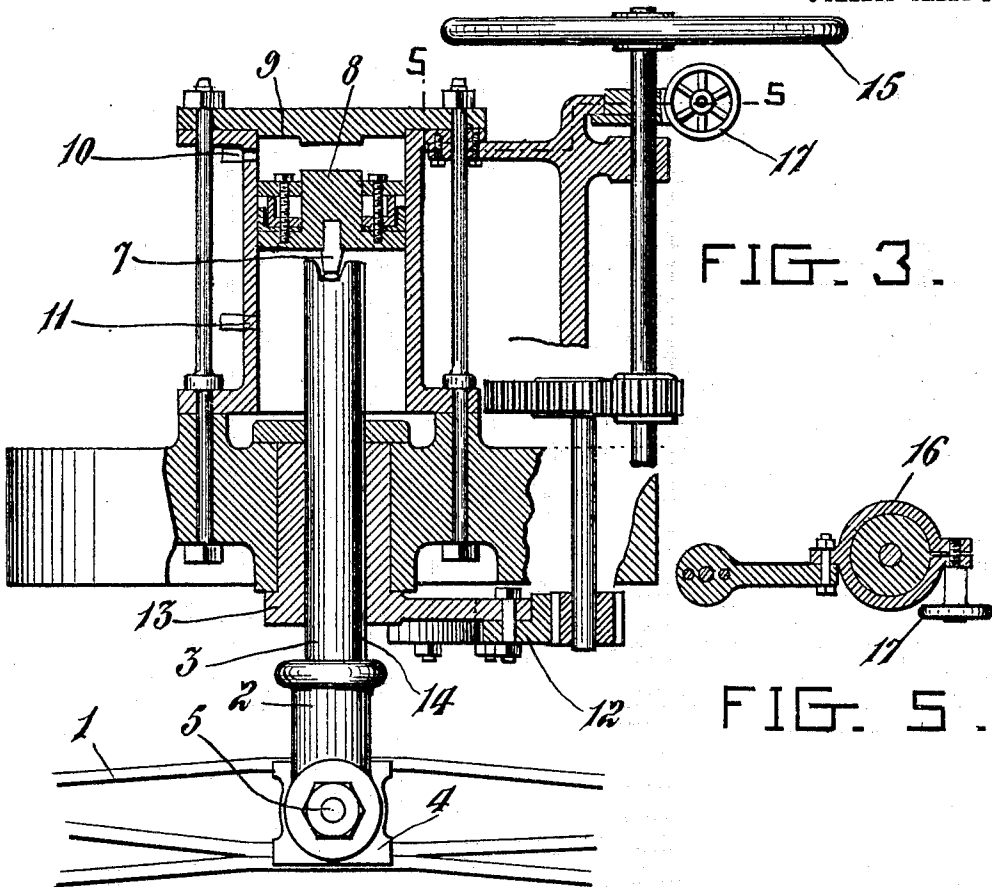

FIG. 3.

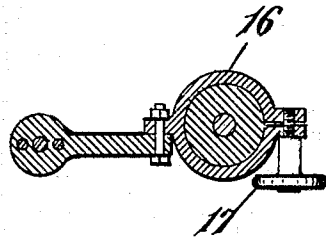

FIG. 5.

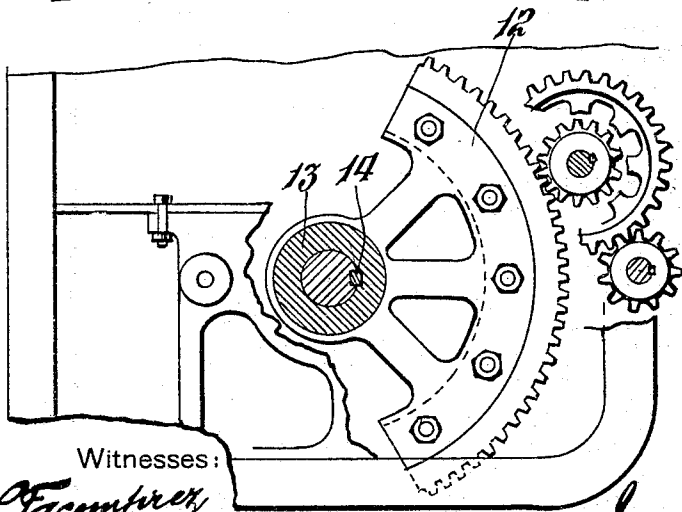

FIG. 4.

Witnesses:
C. F. Compney
L. B. Lawrie

Alexander Dunbar
 Inventor.

By *Marion Marion*
 Attorneys

A. DUNBAR.
 LOGGING ENGINE.
 APPLICATION FILED DEC. 7, 1908.

929,662.

Patented Aug. 3, 1909.
 3 SHEETS—SHEET 3.

FIG. 7.

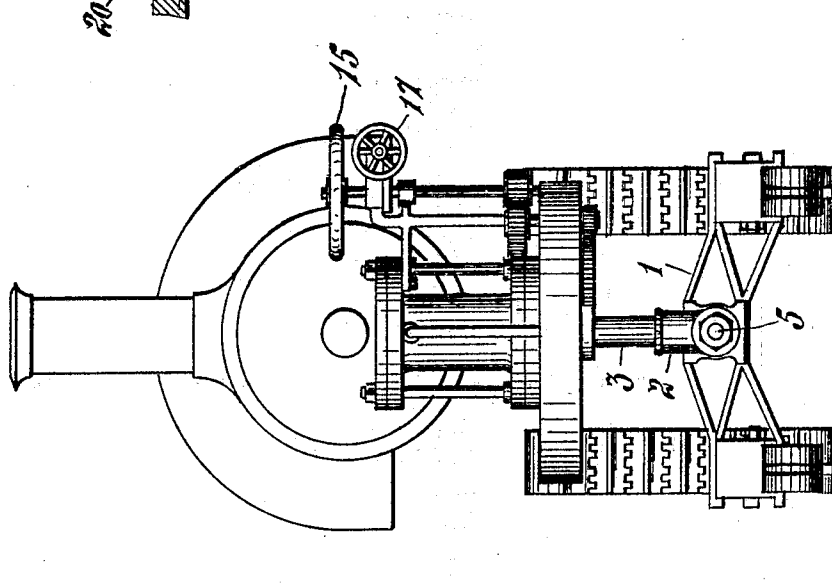

FIG. 8.

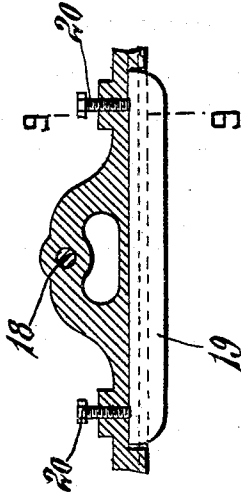
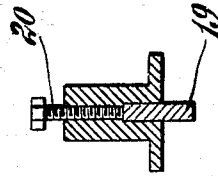

FIG. 9.



Witnesses:
C. Faconprey
L. Gaurin

Alexander Dunbar
 Inventor,
 By *Marion & Maron*
 Attorneys

UNITED STATES PATENT OFFICE,

ALEXANDER DUNBAR, OF WOODSTOCK, NEW BRUNSWICK, CANADA.

LOGGING-ENGINE.

No. 929,662.

Specification of Letters Patent.

Patented Aug. 3, 1909.

Application filed December 7, 1908. Serial No. 466,276.

To all whom it may concern:

Be it known that I, ALEXANDER DUNBAR, a subject of the King of Great Britain, residing at Woodstock, county of Carleton, in the Province of New Brunswick, Canada, have invented certain new and useful Improvements in Logging-Engines; and I do hereby declare that the following is a full, clear, and exact description of the invention, such as will enable others skilled in the art to which it appertains to make and use the same.

The invention to be hereinafter described relates to logging engines, and more particularly to a means for raising or lowering the forward part of the engine boiler as the engine goes down or up a grade, respectively.

As heretofore built, logging engines, in traveling up or down grades, have been at a serious disadvantage, due to the fact that the water in the boiler has settled toward one or the other of the ends of the same, thus leaving the tubes at the opposite end uncovered. Besides this primary objection, several others of considerable importance have been met. One of these is the liability of the forward or guide runners to slide laterally when the engine becomes canted to one side. These runners are flat and smooth, and there is nothing to afford them a grip on the packed snow over which the engine is driven in the winter. It sometimes happens that there are straight stretches of the logging road over which very little attention to the steering gear is needed. In such instances, however, according to prior constructions, the driver must be at the steering wheel regardless of the character of the road. Then again, many sections of the road will be found very uneven. This unevenness of the roads has a very injurious effect on the known constructions of logging engines, because they cannot adapt themselves to such irregularities. It is with an idea to overcoming these main objections and many other minor objections, that the present invention has been designed.

In order to more clearly disclose the construction, operation and use of the invention, reference should be had to the accompanying drawings forming part of the present application.

Throughout the drawings like reference characters designate the same parts.

In the drawings: Figure 1 is a side elevation of the forward part of the engine, partly

raised; Fig. 2 is a front elevation of Fig. 1; Fig. 3 is an enlarged central vertical section through the mechanism for raising the engine boiler; Fig. 4 is a plan view of the steering gears; Fig. 5 is a section on line 5-5 of Fig. 3; Fig. 6 is a vertical cross section through the central knuckle; Fig. 7 is a front view of the engine and its raising mechanism, with the engine boiler raised; Fig. 8 is a partial vertical longitudinal section of one of the runners; and Fig. 9 is a cross section on line 9-9 of Fig. 8.

Any well known frame or support may be used for the engine and boiler, which, also, may be of usual construction. The forward end of this main frame is supported on runners formed of angle irons spaced slightly apart at their longitudinal centers, for a purpose to be later disclosed. These runners are coupled together by a plurality of struts or braces 1. At the center of these struts is mounted a coupling block 4, to which is pivotally attached, by a pivot pin 5, a yoke 2, which is fixed to the lower end of a piston rod 3. The upper end of this rod is notched to receive a wedge-shaped block 7, projecting from the lower face of a piston block 8. Between the block 7 and the bottom of the notch may be interposed any suitable anti-friction device or material. The notch also serves as an oil cup for the loose connections between the piston block and the piston rod. The piston block 8, as a whole, comprises a main section consisting of a circular disk having a centrally extended cylindrical portion, and an annular disk of the same diameter as the first disk, but provided with an opening adapted to receive the cylindrical portion of the first disk so that it may be adjusted toward or from the first disk. Such adjustment, of course, acts to vary the thickness or depth of the piston block, as a whole, and consequently makes it possible to adjust such thickness so as to avoid any possibility of binding between the piston block and the interior of the cylinder. This piston block is adapted to slide within a cylinder 9, provided with inlet and exhaust ports 10 and 11 respectively. The exhaust port is placed a distance above the bottom of the cylinder 9 a little more than equal to the depth or thickness of the piston block. Consequently, it is impossible to force the piston block so low as to have it engage the bottom of the cylinder. The piston is operated, of course, by admission of fluid to the cylinder above

the piston block, or exhaust of the same therefrom, as may be desired. This fluid should be a difficultly freezable substance, such as glycerin or the like. In the preferred form of the machine, this fluid is carried in a tank at the rear of the engine and is delivered to and from the piston cylinder through suitable pipes controlled by valves within reach of the engineer.

The adjustment of the annular disk of the piston block may be effected by threaded bolts or screws passing therethrough and taking into the main disk of the piston block. In order to insure a snug fit between the cup washer of the piston block and the cylinder face, the annular disk may be perforated and the upturned flange of the main disk may be similarly perforated, thus allowing the fluid above the piston to pass through the piston and into direct contact with the face of the cup washer, forcing it against the cylinder wall at all times.

In order to steer the engine, it is necessary, of course, to rotate the piston rod 3, to which are connected the forward or guide runners. Such rotation is effected through a segment gear 12, which is detachably secured to a flange of a sleeve 13, which is let into a casing on the forward part of the frame. This sleeve is provided with a key-way adapted to slidably receive a longitudinal feather 14. Thus, the piston rod may move vertically through the sleeve, but is forced to rotate with it. For moving the segment gear, several intermediate gears and a hand wheel 15 may be used. The shaft of this hand wheel passes through a split sleeve 16, which may be tightened by a thumb nut 17, or like means. When thus tightened, the shaft of the steering wheel, and, consequently, the forward runners, will be tightly locked against movement. Of course, the split sleeve 16 may be tightened just sufficiently to brake the movement of the runners. The pivot pin 5 connecting the lower end of the piston rod 3 with the block 4 at the center of the struts, acts as a knuckle, allowing a runner on one side of the engine to assume a higher or a lower position than that of the runner on the opposite side of the engine. When the road is very irregular, it will be desirable to provide means whereby the opposite ends of each runner may be raised or lowered from the normal hori-

zontal level. To this end, each runner is connected by a pivot pin or knuckle 18, to a block carried in the outer end of the struts 1. In this way, the runners have individual rocking movement to and fro of their lengths and bodily vertical movement relatively to the lower end of the piston rod 3.

Each of the runners is formed of two angle irons spaced apart at their longitudinal centers to form a slot or passage, in which is seated a keel 19, which projects slightly below the face of the runner. The upper edge of this keel rests against set screws 20, by which it may be adjusted, as desired. The keel cuts into the surface over which the runners are forced, and catches a hold, which prevents side slipping of the runners.

It is thought that the operation and use of the machine and its several parts will be clear from the preceding detailed description.

Changes may be made in the construction, arrangement and disposition of the several parts of the invention, without in any way departing from the field and scope of the same, and it is meant to include all such within this application, wherein only a preferred form has been disclosed.

Having thus fully described my invention, what I claim as new, and desire to secure by Letters Patent, is:—

In a logging engine of the character described, the combination comprising a frame, an engine mounted thereon, a cylinder on said frame, a piston block reciprocally mounted in said cylinder, a sleeve reciprocally mounted in the aforesaid frame and provided with a segment gear and a key-way, a piston rod slidably mounted in said sleeve and provided with a feather adapted to be seated within said key-way, and adapted to be actuated by the aforesaid piston block, runners for supporting the forward end of the aforesaid frame, connections between said runners and said piston rod, and means for rotating the aforesaid sleeve to steer the engine.

In witness whereof I have hereunto set my hand in the presence of two witnesses.

ALEXANDER DUNBAR.

Witnesses:

J. NORMAN W. WINSLOW,
G. L. BALMAIN.