

788

J. D. RUSS.
GUN SIGHT.

APPLICATION FILED JULY 13, 1910.

990,783.

Patented Apr. 25, 1911.

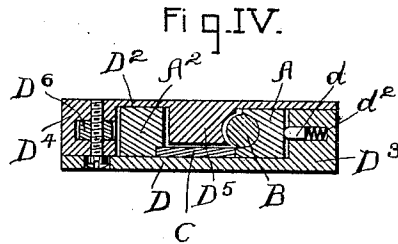
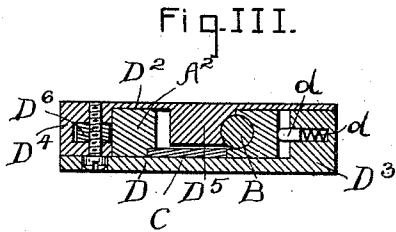
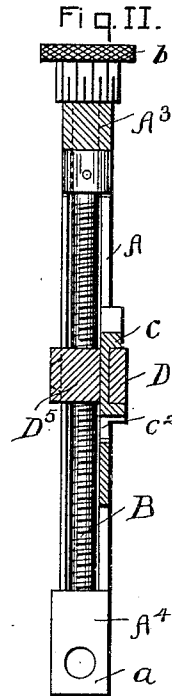
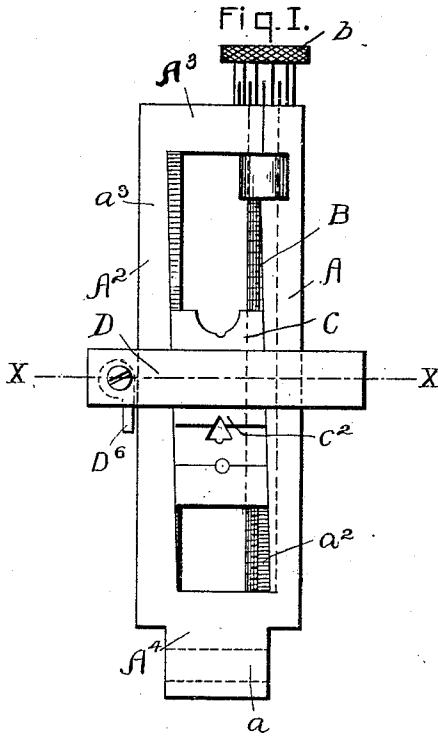

Witnesses
M. Ray Taylor
M. B. Faust.

Inventor
John D. Russ,
 By *H. E. Stonebraker,*
 His Attorney.

1417

212

UNITED STATES PATENT OFFICE.

JOHN D. RUSS, OF SPENCER, WEST VIRGINIA, ASSIGNOR OF ONE-HALF TO F. F. McINTOSH, OF SPENCER, WEST VIRGINIA.

GUN-SIGHT.

990,783.

Specification of Letters Patent.

Patented Apr. 25, 1911.

Application filed July 13, 1910. Serial No. 571,817.

To all whom it may concern:

Be it known that I, JOHN D. RUSS, a citizen of the United States, residing at Spencer, in the county of Roane and State of West Virginia, have invented certain new and useful Improvements in Gun-Sights; and I do hereby declare the following to be a full, clear, and exact description of the invention, such as will enable others skilled in the art to which it appertains to make and use the same.

My invention relates to gun-sights and is intended to supply a much needed want in affording a mechanism for the purpose, which is of simple construction, and easily operated.

The object of my invention is to afford a novel form of gun-sight, in which instrumentalities are provided for quickly adjusting the drift-slide, or giving a fine adjustment thereto, as desired, all of which is accomplished with the fewest possible number of parts.

With these objects and advantages in view, my invention, in one of its preferred embodiments, includes the form and arrangement of parts which I am now about to describe in detail, and as pointed out more fully in the appended claim.

In the drawings, which illustrate one of several ways of carrying out my invention, the same forming a part of this specification, and to be read in conjunction therewith, Figure I is a view in front elevation, of a gun-sight, embodying my improvements; Fig. II is a view in longitudinal section of the same; Fig. III is a transverse, sectional view on the line $x-x$ Fig. I, showing the parts in normal position, for fine adjustment of the drift-slide, and Fig. IV is a similar view, showing the parts disengaged, or in released position, for quick adjustment of the drift-slide.

Referring more particularly to the drawings, in which like characters of reference refer to corresponding parts in the several views, I employ a sight leaf, or standard, comprising wings A, A², a bridge A³ connecting the wings at the top, and a hinge-joint member A⁴ connecting them at the bottom, and provided with an opening a for suitable hinge connection with the gun-barrel, in the usual manner. The wings A, A², are provided with inclined grooves, or undercuts a^2 , a^3 , to permit proper movement of

the drift-slide in order to allow for drift of the ball, as well-known heretofore in this art.

B is a threaded stem inset, partially, in the wing A, and provided at its upper end with the milled nut b . The collar of the nut b is provided with a series of indicating marks, which cooperate with a corresponding mark on the bridge A³, whereby a micrometer adjustment is obtained. The indicating marks on the thumb nut are so positioned, and have such a relation to the threads on the stem, that turning the nut the distance from one mark to the next, will operate the stem sufficiently to raise the drift-slide one inch for each hundred yards. So that, for instance, at one thousand yards, movement from one mark to the next will raise the ball ten inches. As will be quite apparent, other adjustments, and their relations may be obtained, under varying circumstances, as desirable.

C designates the drift-slide, which is enlarged at one end, shown at c , and is provided with a flange c^2 at about its middle portion, so as to form a transverse slot, or groove, for a purpose presently to be explained.

The slide-block comprises two cooperating members D, D². These have corresponding enlargements D³, D⁴, the portion D³ having a groove in its face, to form a dove-tailed connection with member D², as shown in Fig. II. The enlarged portion D³ is also provided with a recess which receives the pin d and expansion spring d^2 , said pin being held in engagement against the side of the wing A. Centrally of the member D² is a projecting flange D⁵, which has a threaded recess in one side, to engage, normally, with the threaded stem B. The enlargement D⁴ is provided with a suitable cam-lever D^c, to lock the slide-block in any adjusted position, the member D being secured to enlargement D⁴ by means of a screw, or other suitable attaching device. The member D engages in the transverse groove, or slot, of the drift-slide aforementioned, which is supported on its inner face by the flange D⁵. For quick adjustment of the parts, the slide-block is pressed slightly to the left, against action of spring d^2 , sufficiently to remove the threaded portion of flange D⁵ from engagement with the stem B. It may then be moved to any position on the sight leaf, with ease.

When the slide-block is relieved from lateral pressure, the flange D⁵ is immediately thrown into engagement with the threaded stem, by which a further, and fine adjustment of the slide-block is obtained. When
5 the desired position of the slide-block is secured, the cam-lever D⁶ is operated to lock it in engagement with the sight leaf.

While I have shown and described a particular form of construction and arrangement,
10 it will be perfectly obvious that my invention is susceptible of various changes and modifications, without departing from the essential features thereof, and by the claim
15 hereto annexed, I desire to include all such additional constructions, as come within the scope and intent of my improvement.

What I desire to secure by Letters-Patent, and claim, is:

A gun-sight including a sight leaf, a 20 threaded stem carried by the sight leaf, a drift-slide having a transverse slot, or groove, a laterally yieldable slide-block in engagement with said groove of the drift-
25 slide, and a threaded flange formed on the slide-block, and in engagement with the aforementioned threaded stem.

In testimony whereof, I affix my signature, in the presence of two subscribing witnesses.

JOHN D. RUSS.

Witnesses:

LEWIS W. GOFF,
E. S. HARPOLD.

Copies of this patent may be obtained for five cents each, by addressing the "Commissioner of Patents, Washington, D. C."
