

(19) **DANMARK**



Patent- og
Varemærkestyrelsen

(10) **DK/EP 1679104 T3**

(12) **Oversættelse af
europæisk patentskrift**

-
- (51) Int.Cl.: **A 63 H 3/36 (2006.01)** **A 63 H 3/44 (2006.01)** **B 29 C 45/14 (2006.01)**
B 29 C 45/44 (2006.01)
- (45) Oversættelsen bekendtgjort den: **2016-10-03**
- (80) Dato for Den Europæiske Patentmyndigheds bekendtgørelse om meddelelse af patentet: **2016-06-29**
- (86) Europæisk ansøgning nr.: **06006276.7**
- (86) Europæisk indleveringsdag: **2000-08-09**
- (87) Den europæiske ansøgnings publiceringsdag: **2006-07-12**
- (30) Prioritet: **1999-08-10 US 371484**
- (62) Stamansøgningsnr: **00965598.6**
- (84) Designerede stater: **AT BE CH CY DE DK ES FI FR GB GR IE IT LI LU MC NL PT SE**
- (73) Patenthaver: **Jetta Company Limited, 19 On Kui Street, Jetta House, On Lok Tsuen, Fanling, Hong Kong, Kina**
FEKETE, Ferenc, 2/F, 99A Main Street, Young Shue Wan, Lamma Island, Hong Kong, Kina
- (72) Opfinder: **Wong, Sui Kay, Flat G & H, 10/F 173, Tin Hau Temple Road, North Point, Hong Kong, Kina**
Fekete, Ferenc, 2/F, 99A Main Street, Young Shue Wan, Lamma Island, Hong Kong, Kina
- (74) Fuldmægtig i Danmark: **Holme Patent A/S, Valbygårdsvej 33, 2500 Valby, Danmark**
- (54) Benævnelse: **En støbeform og en fremgangsmåde til at anvende en støbeform**
- (56) Fremdragne publikationer:
US-A- 4 101 619
US-A- 4 731 014
US-A- 5 470 900
US-A- 5 683 644
US-A- 5 700 415
PATENT ABSTRACTS OF JAPAN vol. 1999, no. 06, 31 March 1999 (1999-03-31) -& JP 01 046496 A
(ENOMOTO:KK; WASHI NO DESIGN:KK), 20 February 1989 (1989-02-20)
FR-A- 889 416
JP-A- H0 178 812
JP-A- H0 788 903
JP-A- H01 110 116
JP-A- H03 129 172
JP-A- S62 101 412
US-A- 2 093 909
US-A- 2 601 741
US-A- 3 106 040
US-A- 3 701 821

DESCRIPTION

BACKGROUND OF THE INVENTION

[0001] The present invention relates to a mold and a method for using a mold.

[0002] Traditionally, soft, hollow toy parts or doll heads were made by either by slush molding, dip molding, or rotocasting processes using latex or PVC, or by blow-molding processes using thermoplastic elastomers. These traditional processes, however, are not able to make hollow parts with controllable and precise wall thicknesses and opening dimensions. Nonetheless, due to the softness and easy processing of PVC, slush molding and rotocasting processes using PVC have been the primary process and the primary material for making one-piece hollow doll heads with direct hair rooting in the past half century.

[0003] In the last decade, however, various research has indicated that PVC material is not environmentally friendly, and more importantly, it may also be harmful to one's health. As a result, some toy manufacturers have been asked to stop using PVC in toys and dolls. Accordingly, there is a need for new materials that are not harmful and do not cause environmental concerns for use in making toys. As well, there is a need for a new process for making soft hollow toy parts with controllable and precise wall thicknesses and opening dimensions.

BRIEF SUMMARY OF THE INVENTION

[0004] The present invention is as defined in the attached claims.

[0005] The invention will be apparent and fully understood from the following Detailed Description of the Preferred Embodiments of the Invention, taken in connection with the appended drawings.

BRIEF DESCRIPTION OF THE DRAWINGS

[0006]

FIGURE 1 is a front-to-back cross-sectional view of the doll's head inside a mold.

FIGURE 2 is a cross-sectional view of the doll's head of a mold of FIGURE 1 taken across lines B-B.

FIGURE 3 is a cross-sectional view of the doll's head of FIGURE 1 taken across lines C-C.

FIGURE 4 is a cross-sectional view of a variation of the doll's head of FIGURE 1 with an overmolded object captured in the head.

FIGURE 5 is a cross-sectional view of a second embodiment of a doll's head inside a mold.

FIGURE 6 is a cross-sectional view of a third embodiment of a doll's head in a mold.

FIGURE 7 is a cross-sectional view of the doll's head of FIGURE 5 being removed from the lower mold half.

FIGURE 8 is a cross-sectional view of the doll's head of FIGURE 6 being ejected off the core.

FIGURE 9 is a side elevation view of a fourth embodiment of the doll's head.

FIGURE 10 is a side elevation view of the doll's head of FIGURE 9 after hair is rooted to the head.

DETAILED DESCRIPTION OF THE PREFERRED EMBODIMENTS OF THE INVENTION

[0007] With reference to the above-identified drawings, the detailed description of the preferred embodiments of the invention will be provided. The directional terms front, rear, left, right, top, bottom, height, width, etc., are provided from the viewpoint of the normal upright position of the doll head taken from the doll's perspective, and are used herein as an aid to identify and describe

the different features of the preferred embodiments of the invention. Those directional terms are not meant, however, to limit the invention in any respect.

[0008] Also, the invention is described with respect to the preferred embodiment of a doll head. However, that term is not meant to be limited to any particular type of toy doll, and not limited to human characters. As used herein, the term "doll head" could be the head of any toy, figurine, souvenir, animatronic robot, and the like, that represents a human figure, an animal, living or extinct, or even a fictitious character of unknown origin, such as an alien from another planet.

[0009] FIGURES 1, 2, and 3 illustrate one preferred embodiment of the invention. A hollow doll head 10 is depicted in a two-part injection mold 11. The head is defined by the gap between the two parts of the mold, and formed by injection molding a melted thermoplastic elastomer into that gap. Notable features of the head includes the face 12 or front of the head, the back 13 of the head, the top 14 of the head, the eye socket 15, the nose 16, the neck 17, the neck opening 18, the ears 19, and the part line 20.

[0010] The two-part injection mold 11 includes an exterior mold portion 21 and an interior core assembly 22. The exterior mold portion is itself made of two mold halves: a front mold half 23, and a rear mold half 24. The front mold half 23 is so-called because it is cut to define the features of the front 12 of the doll head, and the back mold half 24 is so-called because it is cut to define the features of the back 13 of the doll head. The two exterior mold halves 23, 24 come together around the widest portion of the head and, due to normal injection molding processes, form the part line 20 on the doll head at that junction.

[0011] The interior core assembly 22 is composed of four separate solid core pieces. The core assembly 22 includes a front center core section 25, a rear center core section 26, a left core section 27, and a right core section 28. Those core sections, or pieces, assemble, preferably in an interlocking manner to hold together, to form the interior shape and surface of the hollow interior of the doll head. Assembled, the interior core assembly 22 has a major hollow dimension 29 (i.e., the largest width dimension of the core assembly) that is larger than the opening dimension 30 in the neck. Preferably, the individual core pieces have a major piece dimension 31 (i.e., the largest width dimension of the core piece) that is smaller than the major hollow dimension 29. More preferably, the core pieces have a major piece dimension that is about the same size as the opening dimension 30 in the neck.

[0012] As can be seen in FIGURES 1-3, the head 10 is formed in the gap created between the interior core assembly 22 and the exterior mold 21. This interior/exterior two-part molding technique can be used to define precise wall thicknesses at specific locations in the head. For example, the wall thickness may be varied by sculpting the exterior mold to create specific facial features, such as a nose 16. Likewise, the thickness may be easily controlled around the neck 17 to create a wide flange 32 at the base of the neck that may provide for secure attachment of the doll head to a doll body (not shown).

[0013] Moreover, another advantage of this molding technique is the ability to form openings anywhere in the head. For example, FIGURE 1 depicts an eye socket 15 located where the front center core piece 25 contacts the exterior mold half 23. This closes the gap between the two parts so that no melted thermoplastic elastomer can flow there.

[0014] Taking this feature further, removable objects may be located between the interior and exterior mold parts, which would be overmolded by the injected thermoplastic and captured by the formed doll head. FIGURE 4 shows this variation of the doll head of FIGURE 1. In this variation, an eye bead 33 may be placed on a post 34 in the front center core piece 25. The core assembly 22 and eye bead 33 are placed within the exterior mold 21. When the melted thermoplastic is injected, it flows around the eye bead 33 and into an optional groove 35 in the eye bead to create a retaining overmold. When the molds are removed from the head, the eye bead slips off the post and is permanently retained in the head. Alternatively, to retain the eye bead, it may be made of a material compatible with the elastomer used for the doll head so that the eye bead surface would melt and adhere to the doll head material.

[0015] A typical molding procedure for use with the mold shown in FIGURES 1-3 is as follows. The core pieces 25, 26, 27 and 28 are assembled, and interlocked, and placed in the first mold half. Then the second mold half is closed over the first mold half and held tightly together to prevent injected plastic from forcing the mold halves apart and squeezing out from the cavity. Melted thermoplastic elastomer is injected and fills up the cavity defined by the gap between the interior and exterior mold parts. After the thermoplastic cools down and is solidified, the first mold half is opened, and the head with the core assembly inside it are pulled out of the second mold half.

[0016] The interior core assembly is then removed from the head. First, the rear central core piece 26, which predominantly sits over the neck opening 18, is removed. Then, the front central core piece 25 is pulled back from the front of the head 12 and pulled out through the opening 18. Then the left and right core pieces 27 and 28 are removed in any sequence. After the core

pieces are removed from the head, any thermoplastic residue is removed and the pieces reassembled into a core assembly for reuse in the next injection molding cycle with the cleaned exterior mold halves.

[0017] The interior core assembly may be designed for removal in any desired sequence. Preferably, the core assembly is designed with at least one key piece that must be removed first before any other pieces can be removed from the doll head. More preferably, the core assembly is designed with at least two key pieces that must be removed in a specific sequence before removing the remaining core pieces from the molded doll head. As shown in FIGURE 2, because the rear center core piece lies over the opening 18, it must of necessity be removed first before the other pieces can be removed. Likewise, the front center core piece must be removed next.

[0018] The advantage to using this molding technique is that injection molding can be performed to precisely mold hollow parts with major hollow dimensions much greater than the openings through which the interior core piece or pieces are to be removed. It is believed that there is no limit on the largest undercut ratio (i.e., the ratio of the major hollow dimension to the neck opening dimension) that would work with this method for injection molding a doll head, because one may use as few as two, or more than a hundred interior core pieces to make the interior core assembly. Of course, there are practical limits to the cost effectiveness for using so many core pieces. On the other hand, one may use as few core pieces as practicable depending only on the ability of the dolls head to stretch around the major piece dimension. That ability depends on many factors, such as the flexibility of the thermoplastic elastomer, the wall thickness around the opening limiting the stretchability of the neck opening, the temperature of the material when the core is removed, etc.

[0019] Referring now to FIGURE 5, a second preferred embodiment of the invention is shown. A doll head 40 is shown inside an injection molding device. The mold base 41 and the mold block 42 contain an exterior mold part 43 having a front mold half 44 and a back mold half 45. The mold halves enclose an interior core 46 that includes a core stem 47. The stem 47 extends through the mold halves 44 and 45 and connects to the mold base 41. Between the interior core 46 and the mold halves, there is a cavity defined with a variable thickness corresponding to the form of the doll head 40 that is to be molded in that cavity. The front mold half 44 and the back mold half 45 meet along the sides and top of the doll head to create a part line 48 on the surface of the head at that junction. The core stem 47 contacts the exterior mold halves at the bottom 49 of the head to define an opening 50 in the head through which the core 46 will need to be removed. The core has a major hollow dimension 51 that is larger than the dimension 52 of the opening, requiring that the opening stretch around the core 46 to allow its removal.

[0020] In this particular embodiment, the doll head is formed by placing the core 46 and stem 47 within the exterior mold halves 44 and 45. Then melted thermoplastic elastomer is injected into the cavity formed between the interior core and the exterior mold halves. After the elastomer has sufficiently cooled, the exterior mold halves 44 and 45 slide apart and the mold block 42 and core 46 are pulled out from the molding device 53 with the molded doll head 40 attached around the core 46. The hollow doll head is then removed from the core by hand with a tool, or other mold ejection assist, such as air ejection. For air ejection, a hollow conduit may pass through the center line of the core 46 and stem 47 into the hollow interior of the doll head. Air would be injected through the conduit and into the head to partially inflate and stretch it, so it can be easily removed off of the core.

[0021] Referring now to FIGURES 6-8, a third preferred embodiment of the invention is shown. This embodiment includes a double-ejector system for removal of the doll head from the mold. A doll head 55 is shown inside exterior mold halves that include a top mold half 56 and a bottom mold half 57. Inside the mold halves, there is an interior core assembly 58. The interior core assembly 58 includes a concentric core piece 59 connected to a core sleeve 60 that surrounds and slides along the ejector pin 61. The ejector pin 61 ends with a mushroom-shaped cap 62 in the concentric core piece 59. The cavity 63 between the exterior mold halves 56 and 57 and the core assembly 58 is in the shape of the doll head 55 that is formed by injection molding melted thermoplastic elastomer inside the cavity 63. The doll head has a top 64 formed in the top exterior mold half 56 and a bottom 65 that is formed in the bottom exterior mold half 57. At the junction 66 where the top and bottom exterior mold halves meet, a part line 67 is created that is substantially a continuous circle around the top 64 of the doll head and above the usual location for the ears. The doll head 55 has a hollow interior surrounding the core 58, and an opening 68 in the bottom of head through which the core sleeve 60 and ejector pin 61 pass and contact the bottom exterior mold half 57.

[0022] As can be observed in the sequence of FIGURES 6, 7 and then 8, after forming a doll head 55 by injecting melted thermoplastic into the mold and allowing it to cool, the doll head is removed from the mold by first removing the top mold half 56. Then the core assembly 58, including the core sleeve 60 and ejector pin 61, is pushed up to force the head 55 out of the bottom mold half 57. Some force may be required to squeeze the head out from the mold half because the nose 69 must be flattened to squeeze out of the undercut portion 70 of the mold that defined the shape of the nose. Then, the core sleeve 60 is retained in a fixed position relative to the ejector pin 61. This may be accomplished by a flanged limit stop 71 on the bottom of the core sleeve 60. The ejector pin 61 is pushed upward forcing the head to slide off of the concentric core piece 59 by stretching the opening 68

in the bottom of the head around the widest part (i.e., major hollow dimension) of the core piece. Then, the doll head 55 may be easily removed from the mushroom-shaped ejector pin head 62 since it has a smaller major dimension than the annular core piece 60.

[0023] It is particularly advantageous for the doll head 55 to have a part line 67 around the top of the head. With the part line 67 located there, it is normal for the doll head to have hair-material rooted on both the top of the head and below the part line. The hair-material, which is made of any natural or synthetic material suitable to resemble hair, should have a sufficient strand density to cover the part line and to make the part line not observable to an ordinary observer holding the doll at arms length. By ordinary observer, it is meant a person holding the doll for the purpose of casual observation or play, and not for detailed inspection.

[0024] Referring now to FIGURES 9 and 10, a fourth embodiment of a doll head is shown. The doll head 75 includes a pull tab 76 projecting from the top 77 of the head. The pull tab 76 is useful for grasping and pulling the head off of the interior core during the step of removing the head from the core after the injection molding process. The pull tab 76 may then be cut off leaving a tiny vestige 78 on top of the doll head. The head 82 may be rooted with hair 81 over the top of the head so that the vestige 78 is not observable. As shown in FIGURE 9, as would be expected for a doll head made with molds as shown in FIGURES 1-5, the part line 79 of the head extends around the lateral sides of the pull tab 76 down across the ears 80 and down the side of the head. Alternatively, the pull-tab may also be added to molds as shown in FIGURES 6-8, in which case, the part line would circle around the top of the head and would be hidden by the rooted hair.

[0025] A variety of injection-moldable flexible thermoplastic elastomers may be used with this invention. The material may in particular be selected from poly (vinyl chloride) (PVC), ethylene vinyl acetate copolymer (EVA), any of the polymers sold under the trademark KRATON by Shell Chemical Co. (such as optionally hydrogenated) styrene-ethylene/butylene-styrene (S-EB-S), styrene-butadiene-styrene (S-B-S), styrene-isopropene-styrene (S-I-S), styrene-diene, styrene-isoprene and styrene-butadiene block copolymers, styrene-ethylene-butylene block copolymer containing mineral oil, branched styrene copolymer, styrene-butadiene rubber, styrene-butadiene triblock rubber, styrene-isoprene-styrene linear block polymer, styrene-butadiene radial block copolymer, butadiene-styrene copolymer rubber, or synthetic rubber) and low density polyethylene (LDP). Another potentially suitable thermoplastic elastomer is sold by Monsanto under the name SANTOPRENE. Preferably, an S-B-S, S-I-S or S-EB-S copolymer is used. More preferably, S-B-S copolymer is used.

[0026] Preferably, the thermoplastic elastomer is sufficiently flexible to stretch and allow the larger interior core pieces to be extracted from the interior of the hollow molded parts. It is preferred to use a thermoplastic elastomer from which doll heads and other soft hollow toy parts with sufficient realism can be molded, while avoiding increased difficulty in molding detail and in removal of the molded parts from the mold, and removal of larger cores through smaller openings.

[0027] In particular, a thermoplastic elastomer marketed by Shell Chemical Company under the name KRATON D is preferred because of its resilience, strength and durability, and its ability to form a strong and reliable solvent bond (e.g., using Toluene as the solvent). KRATON D is an S-B-S block copolymer, and is reportedly suitable for food and drug use applications, making it a good choice for use in toy parts where there is concern about the harmful effects of the toy material on children.

[0028] In regard to the flexibility and stretchability of the material used to make the hollow toy parts, KRATON has an elasticity, or elongation, that ranges up to between 260% and 550%, depending on the grade selected. If a grade of elastomer is used in this invention with a higher elongation, then a larger interior core piece may be removed through a smaller opening in the toy part. The amount of force required to extract the undercut core will depend on the wall thickness of the toy part around the opening, and how much that opening needs to be stretched. The opening should not be stretched too far to prevent tearing or damage to the toy part.

[0029] Accordingly, to limit the amount of stretching and/or the amount of force required to extract the core from the toy part, it may be desirable to use, instead of a single core, a multiple-piece interior core assembly such as depicted in FIGURES 1-4. As a suggested guideline for when it may be more desirable to use a multiple-piece interior core assembly, based on experience with using KRATON D in the present invention, it is believed that for thermoplastic elastomers having a Hardness below 40 Shore A, a single core may be used with an undercut ratio up to about 3. For harder materials, with a Hardness above 40 Shore A, a single core may be used with an undercut ratio up to about 2. As stated previously, the undercut ratio is the ratio of the major hollow dimension over the opening dimension through which the core is removed. Therefore, for mold designs above those undercut ratio limits, it may be more desirable to use the multi-piece interior core assembly. As well, that undercut ratio limit is a useful guide in determining the maximum major dimensions of the individual pieces in the interior core assembly.

[0030] In the molding process according to the present invention, the injection molding processing conditions follow traditional processing parameters that depend on the type and grade of thermoplastic elastomer selected. For example, in a typical injection

molding process, the bulk of the materials of the composition are thoroughly mixed to provide a uniform feedstock. The feedstock is next processed to be suitable for injection into an injection mold. In another vessel, pigment, polystyrene and a small portion of the thermoplastic elastomer (such as S-B-S copolymer) are mixed to homogeneity. The prepared feedstock and the pigment-bearing mixture are then injected into the mold, generally over a period of from about 0.02 to about 6 seconds, typically from about 0.03 to about 2 seconds, and preferably from about 0.04 to 1 second. The molding pressure is generally from about 200 psi to about 1000 psi, typically from about 300 psi to about 800 psi, and preferably from about 400 psi to about 700 psi. The molding temperature is generally from about 300°F. to about 550°F., typically from about 325°F. to about 425°F., and preferably from about 350°F. to about 400°F. The mixture is generally maintained in the mold from about 20 seconds to about 90 seconds, typically from about 30 seconds to about 80 seconds, and preferably from about 35 seconds to about 60 seconds. Further preferably, the molding is performed as quickly as possible. Further, no special venting is required.

[0031] In particular, the preferred material, KRATON D has a normal processing temperature range of 300°F to 390°F, and a typical injection pressure of between 500 psi and 1000 psi, as noted in the Shell Chemical Technical Bulletin, SC:455-96. The injection molding methods of this invention work within the normal established processing parameters for KRATON D, and require no special processing requirements. It is also expected that other materials would not require special processing parameters to be used.

[0032] Optionally, the air in the mold at the beginning of a mold cycle may be removed from the mold by means of a vacuum assist coordinated with the injection of the elastomer composition. The vacuum assist can be applied for about the last second of the injection period, or it may be first applied after the end of the injection period. Applying the vacuum assist too early in the injection period may result in overly large cell spaces within the molded closure, yielding an overly spongy product. Failure to use a vacuum assist may result in increased cycle times.

[0033] After a time period sufficient for the overall composition to effectively harden within the mold, the mold is opened and the molded part is removed. The interior core is extracted from the part. The part may be painted with a suitable paint that is compatible with the thermoplastic elastomer used. Then, in the case of a doll head, hair may be rooted on to the part.

[0034] Molding times, pressures, venting, cooling vacuum assisting product removal, and other factors relevant to injection molding will be based upon the precise combination of materials included in the overall composition, the type, size and shape of the mold, and other factors apparent to those having ordinary skill in the art.

[0035] Of course, it should be understood that changes and modifications can be made to the preferred embodiments described above. It is therefore intended that the foregoing detailed description be regarded as illustrative rather than limiting, and that it be understood that it is the following claims which are intended to define the scope of this invention.

KRAV

1. Fremgangsmåde til at anvende den i krav 8 definerede
støbeform til at fremstille en blød hul legetøjspart,
5 fremgangsmåden omfatter de følgende trin at:
- a) tilvejebringe en fleksibel termoplastisk elastomer, der
kan sprøjtestøbes,
- 10 b) tilvejebringe en støbeform til den bløde hule
legetøjspart, hvilken støbeform omfatter ydre formparter
(56, 57) og en indre kerne (58), hvori de ydre formparter
(56, 57) er adskilt fra den indre kerne (58), således at
der defineres et hulrum i form af den bløde hule
15 legetøjspart (55), som skal formes, hvori mindst én del af
den ydre formpart (56, 57) er i kontakt med den indre kerne
for at definere mindst én åbning, der skal udformes i den
sprøjtestøbte bløde hule legetøjspart,
- 20 c) sprøjtestøbe den termoplastiske elastomer ind i
formhulrummet for at danne den bløde hule legetøjspart,
idet den bløde hule legetøjspart har en åbning (68) til at
fjerne den indre kerne (58), denne åbning (68) har en
dimension, som er mindre end en dimension af kernen (58),
25 der skal passere gennem åbningen,
- d) åbne de ydre formparter (56,57) for at frigøre den bløde
hule legetøjspart (55) og indre kerne (58) fra en øvre ydre
formpart (56),
30
- e) skyde den bløde hule legetøjspart op og ud af en nedre
ydre formpart (57) under anvendelse af den indre kerne,
- f) fjerne den indre kerne (58) fra den bløde hule
35 legetøjspart (55) via åbningen (68) i den bløde hule
legetøjspart,

5 hvori den indre kerne omfatter mindst to adskilbare sektioner, og trinnet med at fjerne den indre kerne inkluderer, at hver af de adskilbare kernesektioner separat og individuelt fjernes fra den bløde hule legetøjspart gennem åbningen, og

10 hvori den indre kernes mindst to adskilbare sektioner inkluderer en kerneudstøderpind (61) og en kernemuffe (60), der omgiver pinden, og trinnet med at fjerne den indre kerne omfatter, at kernemuffen holdes i en fast position i forhold til udstøderpinden, og udstøderpinden tvinges op mod den bløde hule legetøjspart for at skyde den bløde hule legetøjspart ud af kernemuffen, og at den bløde hule legetøjspart fjernes fra udstøderpinden.

2. Fremgangsmåde ifølge krav 1, hvori åbningen er i bunden af den bløde hule legetøjspart.
- 20 3. Fremgangsmåde ifølge krav 1, og som yderligere omfatter, at den sprøjtestøbte bløde hule legetøjspart males.
- 25 4. Fremgangsmåde ifølge krav 1, hvori sektionerne, efter at den indre kernes adskilbare sektioner er blevet fjernet fra den bløde hule legetøjspart, samles igen og genplaceres i den ydre støbeform for at sprøjtestøbe en anden blød hul legetøjspart.
- 30 5. Fremgangsmåde ifølge krav 1, hvori den bløde hule legetøjspart inkluderer en trækkeapparat, som rager ud fra toppen af den bløde hule legetøjspart, og fjernettrinnet inkluderer, at der gribes fat i trækkeappen, og apparen og den bløde hule legetøjspart trækkes væk fra den indre kerne.

35

6. Fremgangsmåde ifølge krav 1, hvori udstøderpinden ender i en paddehatformet hætte (62), som tvinges mod en indre overflade på den støbte bløde hule legetøjspart for at skyde den bløde hule legetøjespart ud af den ydre støbeforms bund og væk fra kernemuffen.
- 5
7. Fremgangsmåde ifølge krav 6, hvori trinnet med at fjerne den indre kerne yderligere omfatter, at udstøderpinden og kernemuffen samlet bevæges for at skyde den bløde hule legetøjspart ud af bunden i den ydre formpart, indtil et flankeret begrænsningsstop (71) i bunden af kernemuffen ligger an mod den ydre formparts bund for at stoppe kernemuffen i den faste position, og at udstøderpinden fortsat bevæges for at fjerne den bløde hule legetøjspart fra kernemuffen.
- 10
- 15
8. Støbeform til at fremstille en sprøjttestøbt blød hul genstand under anvendelse af en fleksibel termoplastisk elastomer, hvilken støbeform omfatter:
- 20
- en ydre formpart (56, 57), der inkluderer mindst to adskilbar sektioner, og som definerer et formkammer i form af det ydre af den hule genstand, og
- 25
- en indre kernesamling (58), der passer ind i formkammeret inden i den ydre formpart,
- 30
- at den ydre formpart og indre kernesamling er anbragt i afstand fra hinanden for at definere et hulrum, som har en variabel vægtykkelse og samme form som den hule genstand, der skal støbes, og hvori en smeltet termoplastisk elastomer kan indsprøjtes for at danne den hule genstand,
- 35
- at en del af den indvendige kerne er i kontakt med den ydre støbeform for at definere en åbning (68) i den hule genstand, hvorigennem den indre kerne kan fjernes, og

at den indre kernesamling har en hul hoveddimension, der er større end dimensionen af åbningen (68) i den sprøjttestøbte genstand, hvorfra den skal fjernes, efter at genstanden er støbt,

kendetegnet ved, at

støbeformen er udformet med et forudbestemt forhold mellem kernesamlingens (58) hoveddimension og åbningens (68) dimension for at tillade kernesamlingen at blive fjernet gennem åbningen, idet nævnte forudbestemte forhold ligger inden for strækbarhedsgrænserne for åbningen i genstanden, som skal dannes af den fleksible termoplastiske elastomer, og hvori den indre kernesamling omfatter mindst to separate sektioner, som uafhængigt af hinanden kan bevæges i forhold til de ydre formparter, og at hver separat kernesektion individuelt kan fjernes fra genstanden gennem åbningen, efter at genstanden er støbt, og

hvori mindst to adskilbare sektioner af den indre kerne omfatter en kerneudstøderpind (61) og en kernemuffe (60), der omgiver pinden, hvori kernemuffen (60) strækker sig gennem den ydre formpart.

9. Støbeform ifølge krav 8, hvori den indre kernes adskilbare sektioner, efter at være blevet fjernet fra genstanden, kan samles igen for at blive genanvendt til sprøjttestøbning af en anden genstand.

10. Støbeform ifølge krav 8, hvori udstøderpinden (61) ender i en paddehatformet hætte (62).

11. Støbeform ifølge krav 8, hvori kernemuffen (60) inkluderer, at et flankeret grænsestop (71) på bunden af kernemuffen

ligger an mod formparten (57), når kernemuffen strækker sig op og ud af formparten.

- 5 12. Støbeform ifølge krav 11, hvori kernemuffen (60) er den del af den indre kernesamling (58), som er i kontakt med en nedre ydre formpart (57), der definerer åbningen (68) i den hule genstand.

DRAWINGS

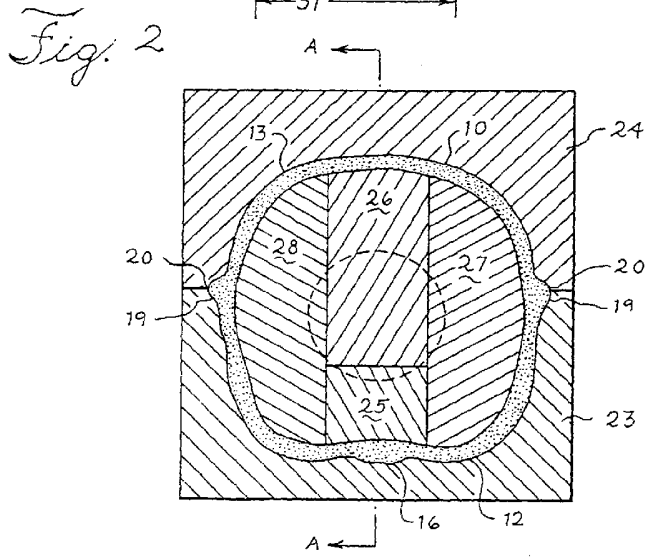
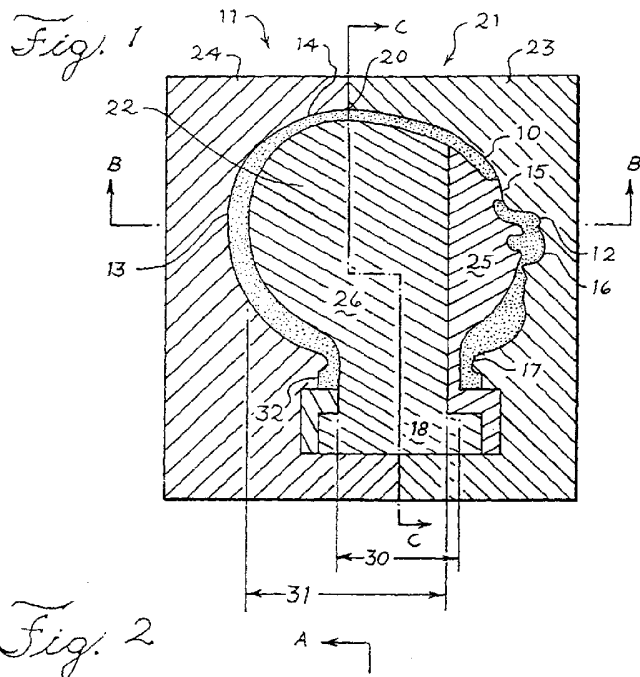

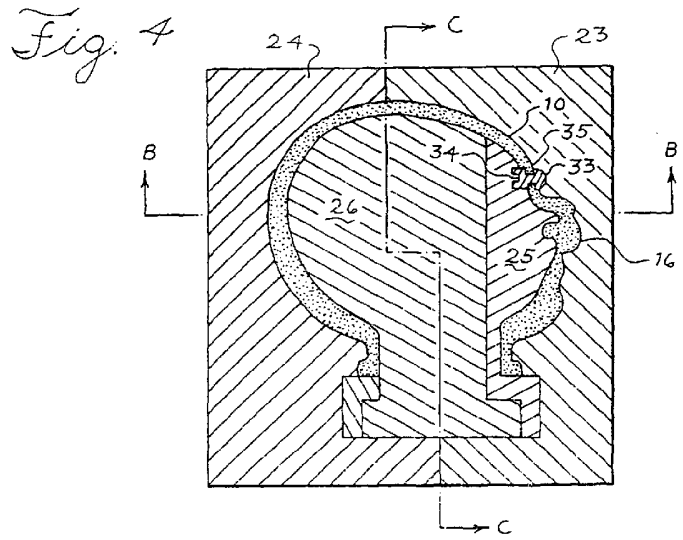
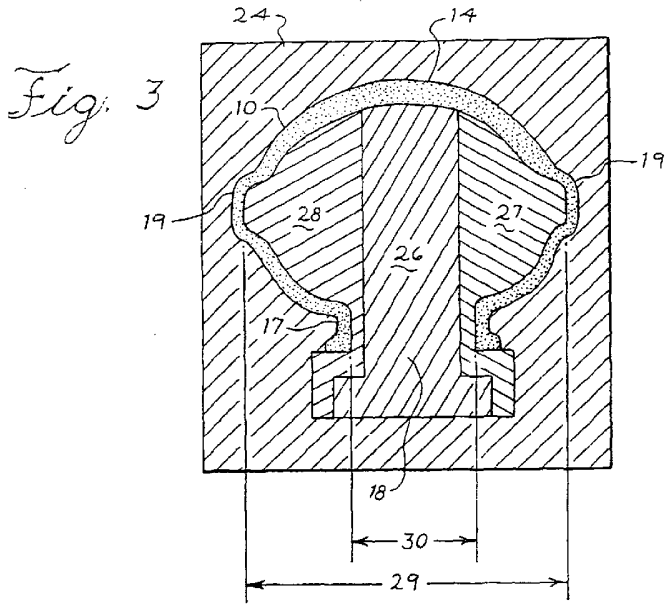
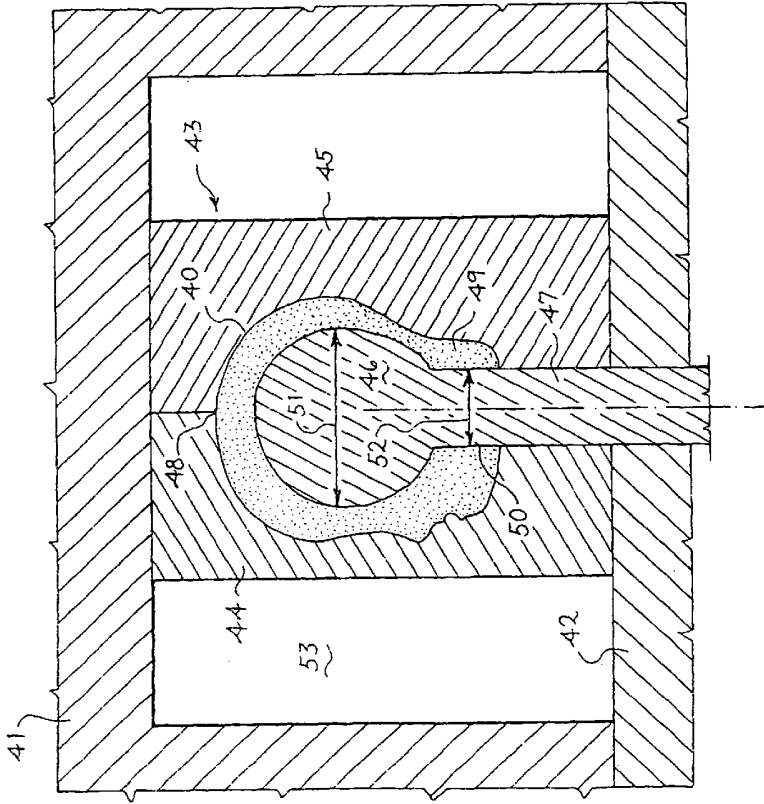
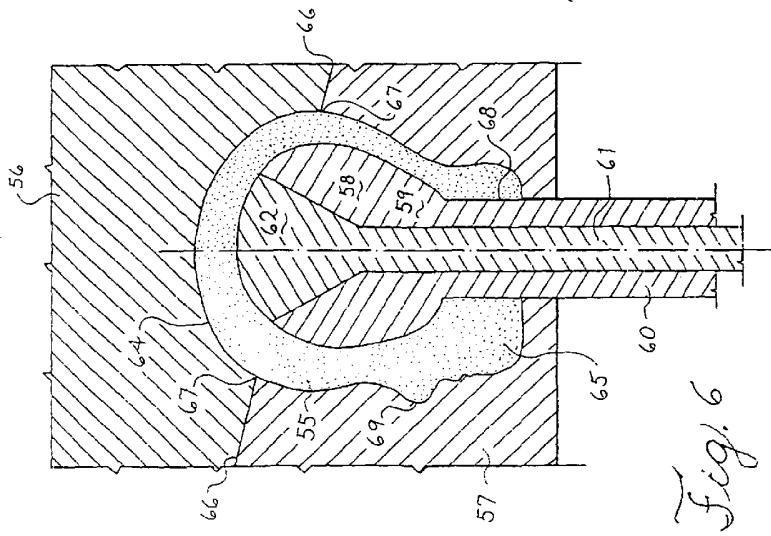
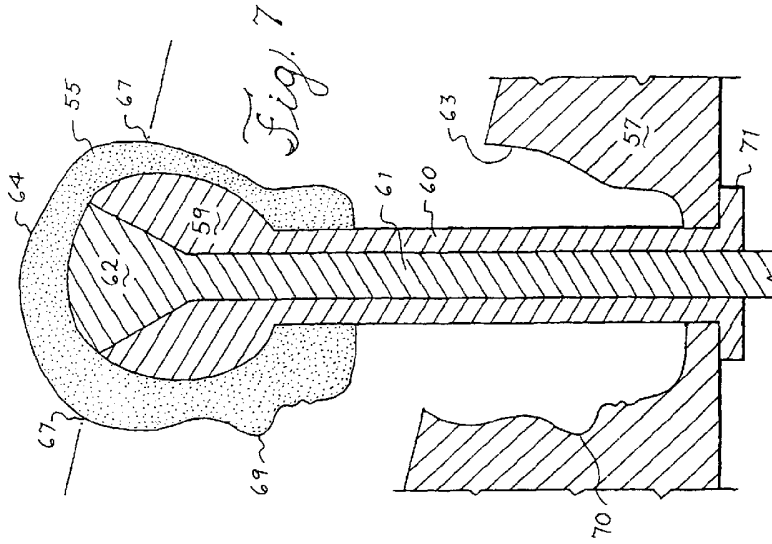

Fig. 5





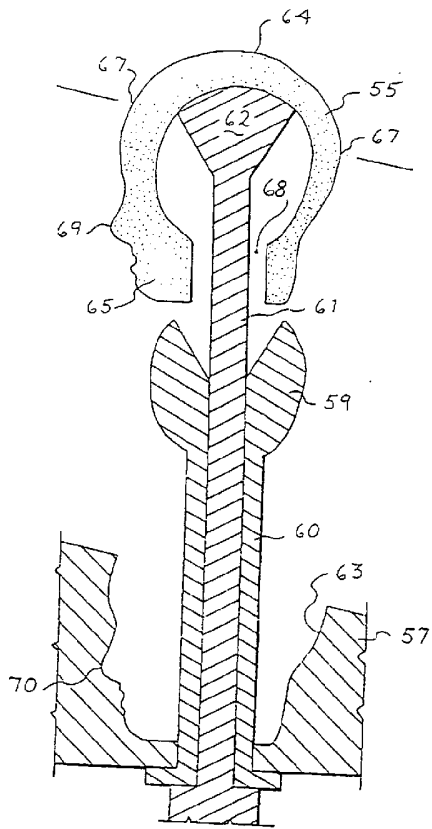

Fig. 8

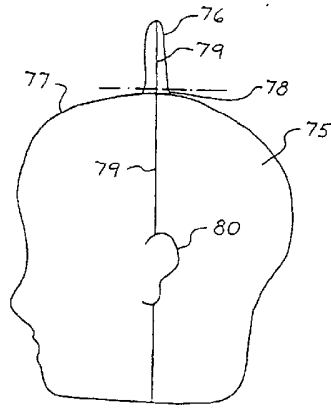

Fig. 9

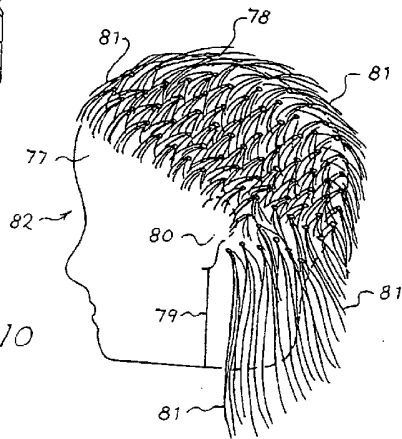

Fig. 10