



US 20060053817A1

(19) **United States**

(12) **Patent Application Publication**
Hess

(10) **Pub. No.: US 2006/0053817 A1**

(43) **Pub. Date: Mar. 16, 2006**

(54) **DIESEL FUEL HEATED DESSICANT
REACTIVATION WITH SAME DIRECTION
REACTIVATION AND PROCESSED AIR
FLOW**

Publication Classification

(51) **Int. Cl.**
F25D 17/06 (2006.01)
F25D 23/00 (2006.01)

(76) Inventor: **Spencer W. Hess**, Whiting, NJ (US)

(52) **U.S. Cl.** **62/271; 62/93**

Correspondence Address:

Charles I. Brodsky
2 Bucks Lane
Marlboro, NJ 07746 (US)

(57) **ABSTRACT**

(21) Appl. No.: **11/223,511**

(22) Filed: **Sep. 12, 2005**

Related U.S. Application Data

(60) Provisional application No. 60/610,254, filed on Sep. 16, 2004.

Dessicants employed in dehumidifying moisturized air present within a water-damaged building are themselves dehumidified to liberate collected moisture through the use of ambient air drawn over and about a heat exchanger fired by diesel fuel, in which the moisturized air and the ambient air are drawn through the dessicant in the same direction.

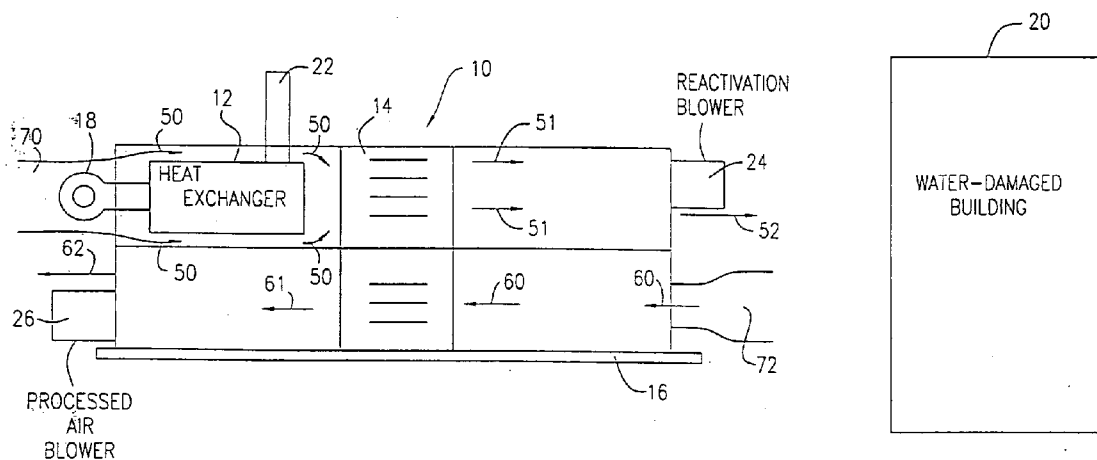

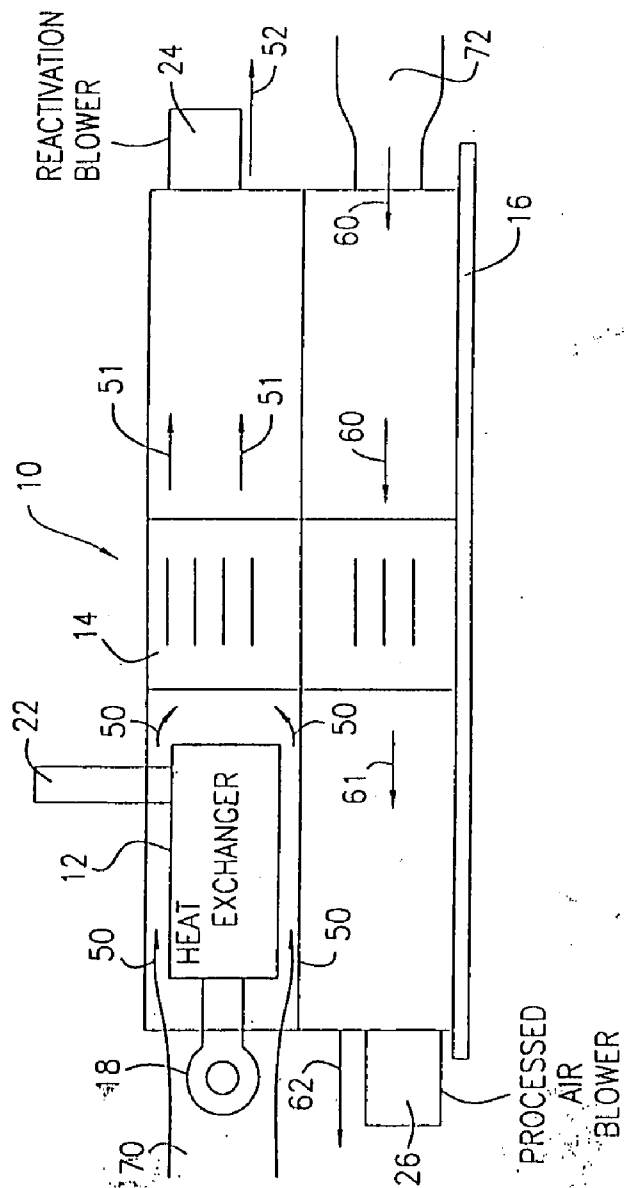
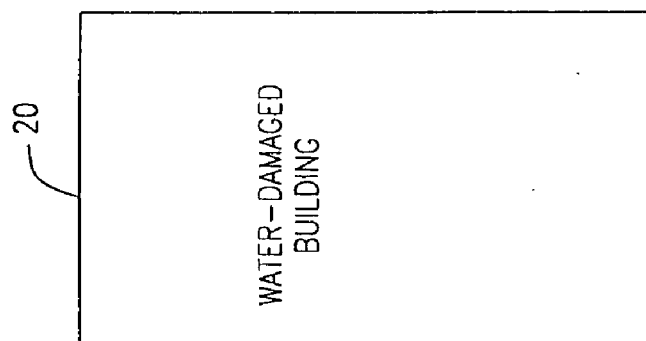

FIG. 1

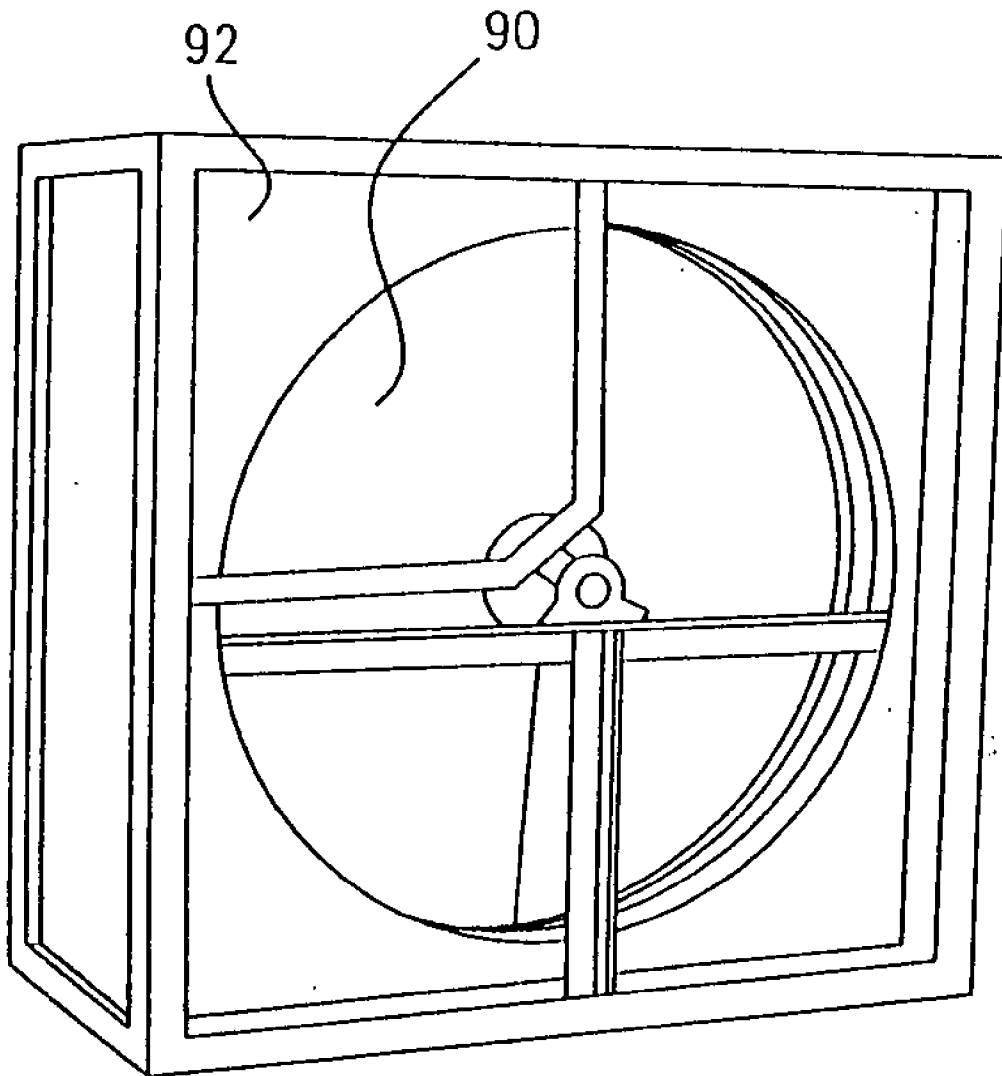

FIG. 2

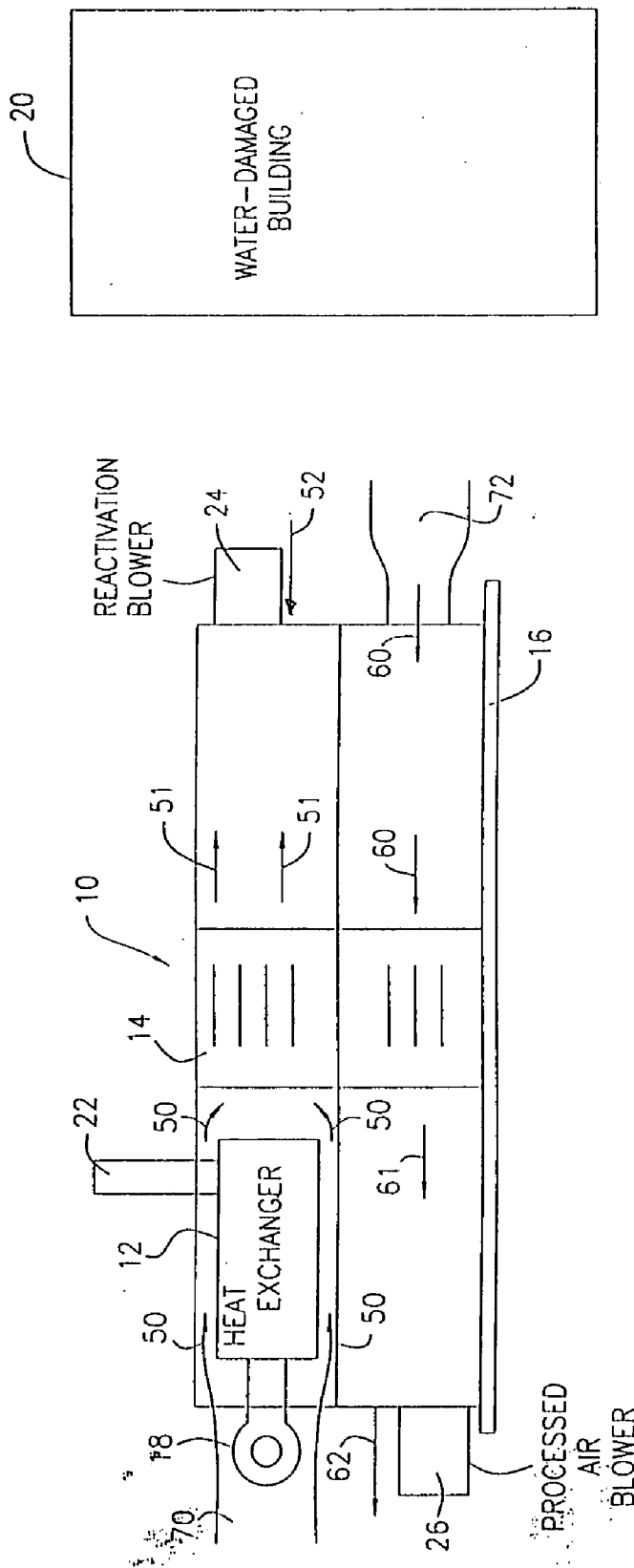

FIG. 3

**DIESEL FUEL HEATED DESSICANT
REACTIVATION WITH SAME DIRECTION
REACTIVATION AND PROCESSED AIR FLOW**

**CROSS-REFERENCE TO RELATED
APPLICATIONS**

[0001] A provisional application describing this invention was filed Sep. 16, 2004, and assigned Ser. No. 60/610,254.

**STATEMENT REGARDING FEDERALLY
SPONSORED RESEARCH OR DEVELOPMENT**

[0002] Research and development of this invention and Application have not been federally sponsored, and no rights are given under any Federal program.

REFERENCE TO A MICROFICHE APPENDIX

[0003] Not Applicable

BACKGROUND OF THE INVENTION

[0004] 1. Field of the Invention

[0005] This invention relates to the restoration industry, in general, and to the drying-out of water damaged buildings, in particular.

[0006] 2. Description of the Related Art

[0007] As is well known and understood, many factors can adversely affect the indoor air quality of buildings, but nothing is as threatening to the indoor environment as water intrusion. As is also well known, when water damage occurs—be it as a result of a burst pipe, a leaky roof or windows, or a flood—it becomes essential to take immediate action. Otherwise, the contents of vital records can be ruined, operations can be disrupted, tenants can be displaced, rental income can be negatively impacted and such irreparable damage can be done as to result in costly repairs or even total loss. As is more and more being appreciated, the moisture can also feed mold growth—which, in itself, is such an onerous threat as to which no building becomes immune.

[0008] As is additionally well known and appreciated, water intrusion often occurs without warning—for example, as a result of hurricane flooding, when pipes burst (frequently in the middle of the night or when no one is around), or when roof air conditioning systems fail.

[0009] When water intrusion of this sort occurs, a professional disaster restoration services provider is summoned to immediately take action to stabilize the environment, mitigate loss, and preserve good indoor air quality. After first quickly identifying “totalled” contents and removing them from the building, the next step is to dry the air using dehumidification systems specifically engineered for that purpose. In particular, the use of dessicant dehumidification systems has grown in popularity as the most effective water abatement technology due to their ability to create low relative humidity and dew point temperatures inside a structure. Unlike cooking-based dehumidifiers (which cool the air to condense moisture and then draw it away), dessicants attract moisture molecules directly from the air and release them into an exhaust air stream. Able to attract and hold many, many times their dry weight in water vapor, such

dessicants are very effective in removing moisture from the air at lower humidity levels, and do not freeze when operated at low temperatures.

[0010] As described in my U.S. Pat. No. 6,652,628 (which issued Nov. 25, 2003), mobile dessicant dehumidifiers have begun to be employed more and more in recent years to dry water damaged buildings to reduce health problems caused by the incipient mold which develops. As is there noted, silica gel is oftentimes employed as the dessicant in a wheel through which the moistened air is pulled from the walls, the floor, the concrete, etc. into the dehumidifying chamber. As the silica gel absorbs the moisture, it became necessary to additionally heat the dessicant to liberate the moisture it collects. Where large scale dessicant equipment is employed, the heat energy required is typically provided by electric heating or propane heating. However, problems existed with both those methods of reactivating the dessicant.

[0011] As my aforementioned patent went on to describe, electrical heating required a large amount of electric power, which many damaged buildings would not have available. Utilizing alternatively provided generators, on the other hand, added additional expense from their rental, along with an accompanying high fuel bill. Propane fuel dehumidifiers, moreover, exhibited many disadvantages of their own: a) Special permits were frequently required to transport the propane to the work site by trailer or other vehicle; b) Additional permits were oftentimes required for working with propane at the work site itself; c) A resupply of propane may not be readily available—as where the building being dried was at a remote location or when a resupply was needed in the middle-of-the-night, or on a Sunday; d) Firing the dehumidifier with propane produced a moisturizing effect which undesirably wetted the processed air being dried; and e) Propane, itself, was highly flammable.

[0012] My patent recognized the need to rapidly dehumidify water-logged buildings and their contents by recirculating air between the building involved and equipment employed—with the air being ducted from the building through the equipment (which absorbs moisture from the air to lower its humidity), and with the dried air being routed back into the building where it absorbs additional moisture from the surrounding air in the building and the building contents. Also recognizing that the recirculation process needs to be carried out continuously, 24 hours a day, until the building interior is determined to be sufficiently dry, such drying process needs to continue for a number of days—especially where a structure such as a hotel or office building has been damaged by water due to a storm or the extinguishment of a fire. However, in order for the dessicant to keep absorbing water, my patent further recognizes that the dessicant must be continuously heated to evaporate the water that it has absorbed. Thus, the equipment employed required an energy source or sources to (i) drive a processed air blower to recirculate air to and from the drying equipment and the building, (ii) drive a reactivation blower to direct heated ambient air through the dessicant, and (iii) heat the ambient air prior to its passing through the dessicant. For a hotel, office building, or other typical commercial building, relatively large amounts of energy continued to be required to heat the ambient air so as to keep the dessicant sufficiently dry—due to the high volumetric rates of air flow involved (measured in cubic feet per minutes).

[0013] As described in my issued patent, on the other hand, such firing of the heat exchanger to heat the air for evaporating moisture from the dessiccant forswore the use of electric heaters or propane burners as previously employed, and proceeded by the burning of diesel fuel—or its equivalent of kerosene or No. 1 or No. 2 fuel oil. As there set out, the diesel fuel thus employed in the heating process was available virtually anywhere where diesel trucks served as a means of transportation. Because diesel fuel provided a greater amount of BTU's per gallon than propane, less fuel was required to provide the heat for the dessiccant than with propane, resulting in a cost savings in use. Also, because such fuel burned without producing moisture, the processed air became that much drier, enabling the reactivation of the dessiccant to be accomplished faster, thereby increasing performance in operation. And, because the dessiccant dehumidifier of the invention operated more efficiently, its construction allowed for a reduction in the required horsepower of the reactivation blower pulling the ambient air over the heat exchanger—resulting in a more compact machine, for easier transportation.

SUMMARY OF THE INVENTION

[0014] As will be appreciated, the operation of my above described patent followed the use of a dehumidifying chamber where the ambient air is drawn from outside the building over and about the heat exchanger through the dessiccant in a first direction, and drawing the moisturized air out from the building through the dessiccant in a second, opposite direction. As will also be understood, while such operation employs a silica gel wheel dessiccant in an arrangement where the heat from the burning chamber passes directly through the wheel, the present invention recognizes that a silica gel wheel dessiccant of alternate construction could be had, to be used in an “indirect fired” environment in which the heated air from the heat exchanger proceeds towards its “off side”, rather than to the wheel. Such a modified construction, it will be understood however, might operate in somewhat of a less efficient manner.

BRIEF DESCRIPTION OF THE DRAWINGS

[0015] These and other features of the present invention will be more clearly understood from a consideration of the following description, taken in connection with the accompanying drawings, in which:

[0016] FIG. 1 is a block diagram helpful in an understanding of the apparatus and method of my U.S. Pat. No. 6,652,628 for dehumidifying moisturized air present within a building from a point external thereto;

[0017] FIG. 2 illustrates a silica gel dessiccant as utilized in the construction of FIG. 1; and

[0018] FIG. 3 is a block diagram helpful in an understanding of the modified apparatus and method for dehumidifying moisturized air in accordance with the present invention.

DETAILED DESCRIPTION OF THE INVENTION

[0019] FIG. 1 illustrates the dessiccant reactivation apparatus of my aforesaid patent and its method of operation through the use of an enclosure 10 having a heat exchanger

12 and a dessiccant 14. Reference numeral 20 identifies a building in which moisturized air is present which the apparatus of the invention is to dehumidify, with the enclosure 10 having a bottom surface 16 which may rest upon a trailer or truck bed adjacent the building 20 once driven to the work site. Alternatively, the enclosure 10 could be off-loaded from the trailer or truck bed onto the ground itself. Reference numeral 18 indicates a diesel fuel burner according to that invention, having an exhaust gas stack 22. As will be understood, the diesel fuel burner 18 heats the exchanger 12 from the inside out.

[0020] As described in such patent, a first, or reactivation, blower 24 draws ambient air from the surrounds via an 18-inch ductwork 70, for example, into the enclosure 10, over and about the diesel fired heat exchanger 12 and through the dessiccant 14 in a first direction, as illustrated by the arrows 50; the moisture liberated, heated air through the dessiccant 14 is discharged outside the enclosure 10 as shown by the arrows 51-52. A second, or processed air, blower 26 draws the moisturized air from within the building through like ductwork 72 and the dessiccant 14 in a second direction (shown by the arrows 60), which traps the moisture therein before discharging the dried air out the enclosure 10 as shown by the arrows 61-62. The diesel fired heat exchanger 12 thus dehumidifies the dessiccant 14 of the moisture collected from the wet building air in reactivating the dessiccant 14 for continuing use.

[0021] In this construction, the ambient air from outside the enclosure 10 is shown as being drawn through the dessiccant 14 in a direction opposite to that in which the moisturized air is pulled from the building through the dessiccant 14. In such manner, of use, a dessiccant 14 including a silica gel composition was particularly attractive in collecting the moisture from the water damaged building's air.

[0022] As will be appreciated by those skilled in the art, such operation follows from the use of the silica gel dessiccant being in the form of a rotating wheel 90 in a frame 92 within the enclosure 10, as shown in FIG. 2. The operation then follows by providing the dehumidifying chamber with the heat exchanger and the dessiccant, drawing the ambient air from outside the building over and about the heat exchanger through the dessiccant in a first direction, and drawing the moisturized air out from the building through the dessiccant in a second, opposite direction. In accordance with this, for example, FIG. 1 shows the processed air blower 26 as pulling the moisturized air from the building right-to-left to be dried, whereas the reactivation blower 24 pulls the ambient air from left-to-right to liberate the moisture collected by the dessiccant. Such construction is typically referred to as “direct firing”, in which the heat from the burning chamber 12 passes directly through the silica gel wheel and its dessiccant.

[0023] The present invention, on the other hand, recognizes that some manufacturer might elect to design a silica gel wheel of alternate construction, to be used in an “indirect fired” environment in which the heated air from the heat exchanger 12 proceeds towards its “off” side, rather than to the wheel. Understanding that such a construction would tend to operate less efficiently, it can be accomplished, however—simply by putting both the reactivation blower and the processed air blower on the same side. Such a construction is as shown in FIG. 3 which, however, operates

to liberate less moisture from the dessicant **14** as where the reactivation air was hotter. As will be seen, the moisture liberated ambient air at arrow **52** flows in the same direction as the dried air from out the wheel as shown by the arrow **62**.

[0024] While there has been described what is considered to be preferred embodiment of the present invention, it will be readily appreciated by those skilled in the art that modifications can be made without departing from the scope of the teachings herein. For at least such reason, therefore, resort should be had to the claims appended hereto for a true understanding of the scope of the invention.

I claim:

1. Apparatus for dehumidifying moisturized air present within a building from a point external thereto having an

enclosure housing a heat exchanger, a dessicant, a first blower drawing ambient air from outside said enclosure over said heat exchanger through said dessicant in a first direction, a second blower drawing said moisturized air through said dessicant in a second direction, and means for firing said heat exchanger with diesel fuel, wherein said first blower and said second blower draw said ambient air and said moisturized air through said dessicant in the same direction.

2. The apparatus of claim 1 wherein said dessicant includes a silica gel composition.

3. The apparatus of claim 1 wherein said dessicant includes a rotating silica gel wheel.

* * * * *