

J. PEPLER.
Dressing Millstones.

No. 109,046.

Patented Nov. 8, 1870.

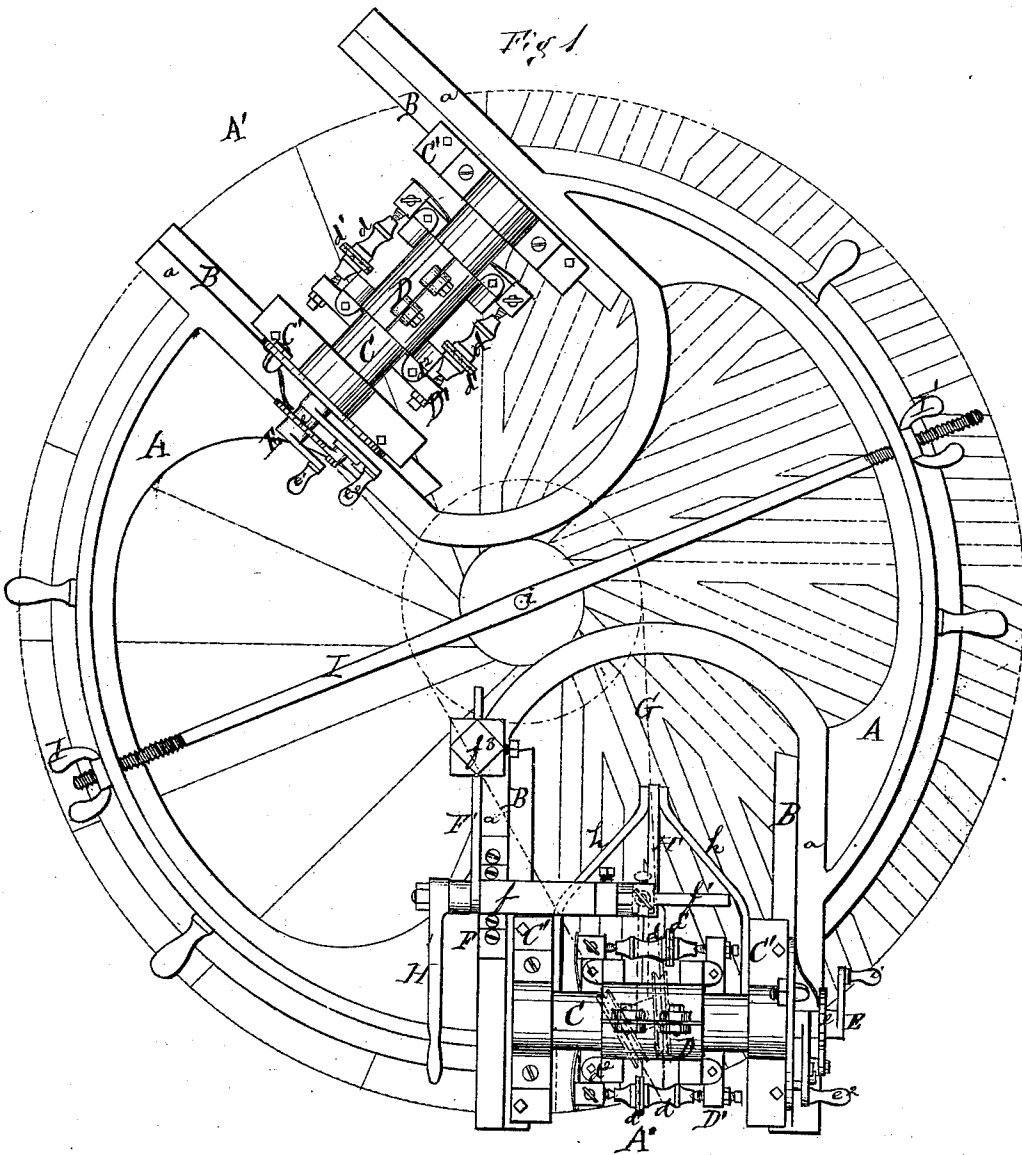

Witnesses.

Alex. Mahon
H. N. Doubleday

James Pepler
by his Attorney
A. M. Smith

J. PEPLER.

Dressing Millstones.

No. 109,046.

Patented Nov. 8, 1870.

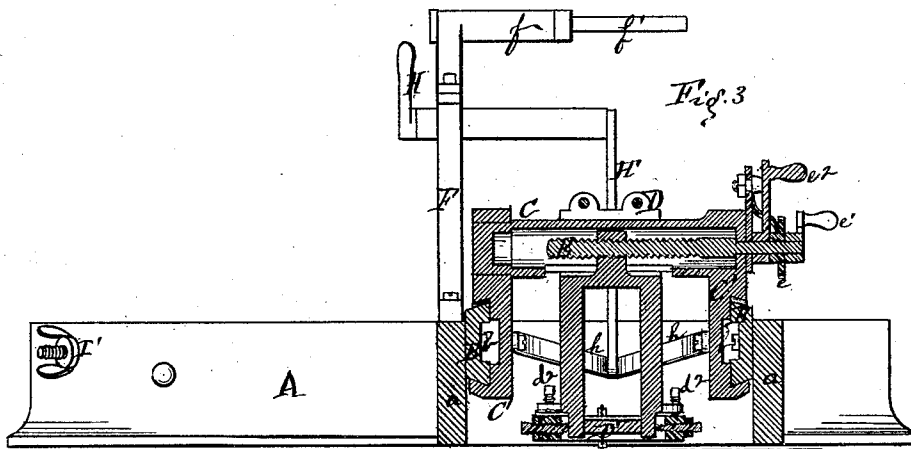
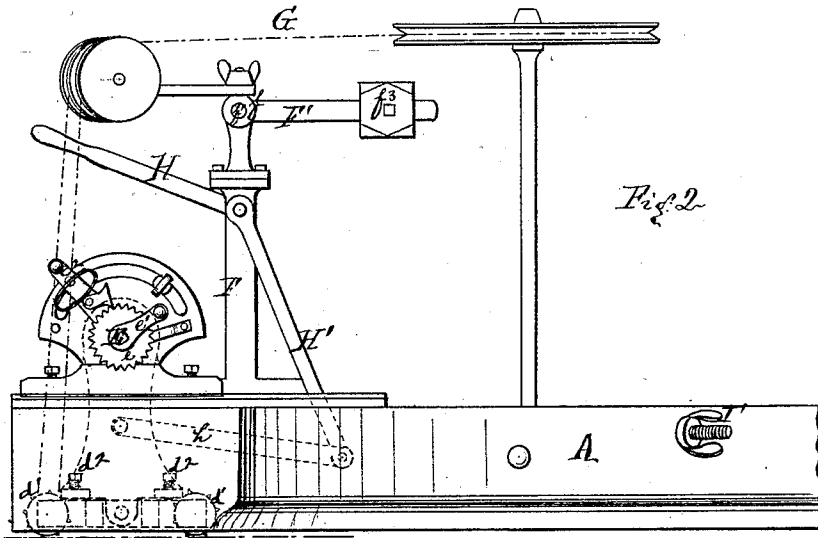

Witnesses.
A. G. Mahon
H. N. Doubleday

James Pepler
by his Attorney
S. M. Smith

United States Patent Office.

JAMES PEPLER, OF BATH, ENGLAND.

Letters Patent No. 109,046, dated November 8, 1870; antedated October 29, 1870.

IMPROVEMENT IN MACHINES FOR DRESSING MILLSTONES.

The Schedule referred to in these Letters Patent and making part of the same.

To all whom it may concern:

Be it known that I, JAMES PEPLER, of Bath, Somerset county, England, temporarily residing at Toronto, Dominion of Canada, have invented certain new and useful Improvements in the Construction of Machines for Dressing Millstones, of which the following is a full, clear, and exact description, reference being had to the accompanying drawing, making part of this specification, in which—

Figure 1 is a plan view of my machine placed upon a millstone;

Figure 2 is a side elevation; and

Figure 3 is a vertical cross-section through line *x y*, fig. 1.

Similar letters of reference denote corresponding parts in all the figures.

The invention relates to that class of machines in which diamonds or other hard stones fixed in revolving disks are employed for cutting the "cracks" in the face of the stone. This class of machines may be divided into two sub-divisions, one of which includes those machines in which there is a device interposed between that part of the machine which rests upon the stone, and that part upon which the cutting apparatus is mounted, the object of this device being to level up the machine to compensate for the inequalities in the height of the different portions of the stone upon which the feet may happen to rest. The other construction referred to is that in which the way or track over which the cutting mechanism travels; is made practicably a part of and rigid with the bed of the machine which rests upon the stone, involving no necessity for any adjustment between the parts. Neither of these constructions has ever been made to accomplish the end sought for, that is, to preserve a true and uniform face upon the stone; and with a view to obviate the difficulties hitherto met with in the employment of diamonds for this purpose, I have invented these improvements.

The invention consists in first constructing the base or bed in a circular form, for the purpose of obtaining, first, a perfect bearing and an absolutely truthful average of the face of the stone; and second, of providing a support for both ends of the arm upon which the cutting apparatus is mounted.

The invention further consists in adjusting the machine upon the stone by means of girt or rest, extending across the circle and secured in position by means of a screw at each end, in such manner that the tangential lines upon which the lands are laid out, will be readily conformed to by the machine, in a manner hereinafter explained.

In the drawing—

A is the bed or base, made preferably in a true circle, with openings A' A', in which to mount and op-

erate the cutting apparatus. This base should be made quite thin or narrow upon its under face, which rests upon the stone, for reasons which will be made apparent.

B are the ways or guides, adjustably secured to jaws *a a'* of the openings by means of bolts *b b*.

C is a tubular carrying-arm, provided with a female dovetail, C', at each end, sliding upon ways B.

Upon arms C is supported the cutting apparatus usually employed in dressing millstones with rotating diamonds, and consisting of the sleeve D, cutter-frame D', spindles *d*, disks *d'*, set-screws *d''*, feed-screw E, ratchet-wheel *e*, cranks *e'* *e''*, and spring pawl *e'*.

F is a standard, provided with a tubular arm, *f*, supporting shaft *f'*, arm F', poise *f''*, and also the guiding-pulleys, over which passes the driving-belt G.

The cutters are moved back and forth lengthwise of the lands by means of lever H, arm H', and links *h h*.

I is a girt, provided with a perforation, *i*, to fit over the spindle in the bed-stone, and over a center which may be established in the eye of the runner.

I' I' are thumb-screws at each end of this girt, for the purpose of making certain adjustments, as will be presently explained.

In locating the openings A' A', care should be taken that the position of jaw *a* be such that the path described by the diamond, when the same is retracted as far as is possible toward said jaw, shall be a line tangential to the eye of the stone, while, at the same time, the spindle of the stone shall occupy the center of the ring, and the openings should be of such width that the cutters may have room enough to dress three lands or an entire quarter, without moving the base, three being the number of adjacent lands that usually lie parallel with each other.

In operating my machine I place it upon the stone and proceed to locate it. This is done by placing the aperture *i* over the spindle or the center in the eye of the stone, which has already been referred to; then, by means of thumb-screws I' I', I so adjust the machine, that the cutters shall traverse the lands in line parallel to the edges of said lands lying next to the front side or deepest part of the furrow. It is evident that, from the fact that all straight lines which may be drawn upon the face of a millstone are either radial or else tangential to a circle having its center coincident with the center of the stone, I can, by means of girt I, so adjust the machine that I can dress an entire stone by merely swinging the machine upon *i* as a center, the machine itself being, as a whole, more or less eccentric to the stone upon which it stands.

Having thus determined the location of the base, I next proceed to form a seat for it thus: I turn it slowly around, dressing down the high points until I obtain a satisfactory seat or track, one which I am satisfied is

truthful and accurate; this done, I have a plane to which I can dress the entire stone with a perfect certainty, avoiding all liability to leaving the stone winding or undulating, as is the result of dressing with any of the machines heretofore used. The preparation of this track involves but little labor, as the machine may be so constructed that its center shall be nearly coincident with the center of the stone, when, with but a narrow or thin rim, the actual surface which it stands upon will be quite small.

In the drawing, owing to an imperfection in laying off the stone, the openings A' A' are not represented as being wide enough to admit of dressing all of the lands in a quarter, but it is designed in practice to build the machine in such manner as will enable one to do so when it is considered advisable. The manner of operating the cutting apparatus is so closely analogous to that pursued in working the other machines of this class, that it is not deemed necessary to give a more detailed description of it.

It will be observed that one of the openings is adapted to dress stones that run with the sun, and the other one those that run against the sun. When the arm is supported at one end only, as has been the case heretofore, the outer end of it will yield a little vertically, thus allowing the cutter to ride over the hard spots, and to cut deeper into the softer spots in the stone, this motion of the arm growing out of the difficulty, in practice, of making the dovetail or other form of way fit with sufficient accuracy and tightness, while permitting freedom of motion of the parts, but, by supporting both ends of said arm or shaft, the defect is remedied. Of course, it is not essential that both or either end of arms C should be supported by a way of the precise form shown; in fact, one end may be terminated by a simple tongue or tenon, and slide in a corresponding groove, the most essential point

being that both ways or tracks shall occupy planes parallel to that occupied by the circular base, thereby enabling me to dress the entire face of the stone to the plane which I have established for the base to rest upon.

The girt I may, if preferred, be attached to and made adjustable upon the flanges of the openings A' A'. One end of one of the tubular arms C is depressed at such an angle as may be required for the purpose of dressing the furrows.

I do not wish to be understood as limiting myself to the employment of rotating diamonds in this machine, as it may be found advantageous to use a diamond having a direct reciprocating motion, or even the ordinary pick operated by proper mechanism; because any cutting apparatus may be adapted to my machine without interfering with the features or principle embodied in my invention, the prominent element in my construction being a base which shall always rest upon the same portion of the stone, and, of course, always occupying the same plane whatever may be its position relative to the different quarters or lands to be dressed.

Having now described my invention,

What I claim as new, and desire to secure by Letters Patent, is—

1. The circular base A, provided with openings, in which to mount the cutting apparatus, substantially as set forth.

2. The base A, in combination with the cutting apparatus mounted upon shaft C, supported at both ends, substantially as set forth.

3. The adjustable girt I, in combination with the bed A, substantially as set forth.

Witnesses:

JAMES PEPLER.

A. W. SHAW,

A. R. FAULKNER.