



(86) Date de dépôt PCT/PCT Filing Date: 2012/02/28  
 (87) Date publication PCT/PCT Publication Date: 2012/09/07  
 (85) Entrée phase nationale/National Entry: 2013/08/27  
 (86) N° demande PCT/PCT Application No.: US 2012/026897  
 (87) N° publication PCT/PCT Publication No.: 2012/118787  
 (30) Priorité/Priority: 2011/02/28 (US61/447,280)

(51) Cl.Int./Int.Cl. *H02K 1/27* (2006.01)  
 (71) Demandeur/Applicant:  
 UQM TECHNOLOGIES INC., US  
 (72) Inventeurs/Inventors:  
 LUTZ, JON, US;  
 LEY, JOSH, US  
 (74) Agent: NORTON ROSE FULBRIGHT CANADA  
 LLP/S.E.N.C.R.L., S.R.L.

(54) Titre : CONSTRUCTION DE MACHINE A AIMANT PERMANENT SANS BALAI AUTORISANT DES AIMANTS A FAIBLE CHAMP COERCITIF  
 (54) Title: BRUSHLESS PM MACHINE CONSTRUCTION ENABLING LOW COERCIVITY MAGNETS

**FIG. 1A**

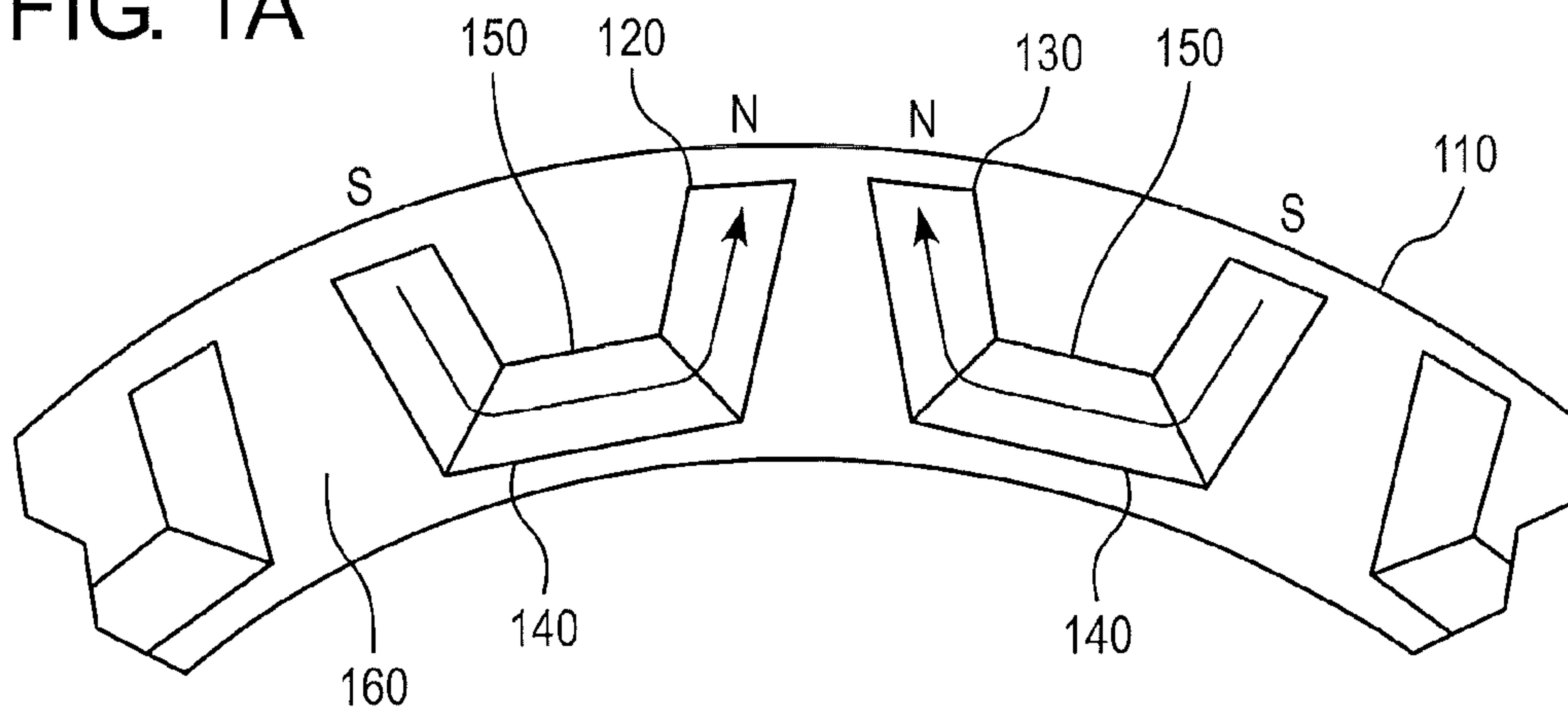

(57) **Abrégé/Abstract:**

The present disclosure provides a brushless permanent magnet machine which includes an essentially circular shaped rotor, and a pair of magnets arranged in the rotor. The magnets are each U-shaped and have a thickness direction extending along a contour of the corresponding magnet between the opposite poles of the corresponding magnet, respectively. The magnets are each composed of a non-rare earth material having a lower coercivity than a rare earth material. A direction of magnetization of each of the pair of magnets is parallel to the thickness direction of the corresponding magnet. The present disclosure also provides a method of manufacturing such a brushless permanent magnet machine.



(12) INTERNATIONAL APPLICATION PUBLISHED UNDER THE PATENT COOPERATION TREATY (PCT)

(19) World Intellectual Property  
Organization  
International Bureau(43) International Publication Date  
7 September 2012 (07.09.2012)(10) International Publication Number  
**WO 2012/118787 A3**(51) International Patent Classification:  
*H02K 1/27* (2006.01)

(21) International Application Number:

PCT/US2012/026897

(22) International Filing Date:

28 February 2012 (28.02.2012)

(25) Filing Language:

English

(26) Publication Language:

English

(30) Priority Data:

61/447,280 28 February 2011 (28.02.2011) US

(71) Applicant (for all designated States except US): **UQM TECHNOLOGIES INC.** [US/US]; 4120 Specialty Place, Longmont, Colorado 80504 (US).

(72) Inventors; and

(75) Inventors/Applicants (for US only): **LUTZ, Jon** [US/US]; 9408 W. 104th Way, Westminster, Colorado 80021 (US). **LEY, Josh** [US/US]; 2228 Alpine Drive, Erie, Colorado 80516 (US).(74) Agents: **ROWLAND, William C.** et al.; Buchanan Ingersoll & Rooney Pc, (Customer No. 21839), P. O. Box 1404, Alexandria, Virginia 22313-1404 (US).

(81) Designated States (unless otherwise indicated, for every kind of national protection available): AE, AG, AL, AM, AO, AT, AU, AZ, BA, BB, BG, BH, BR, BW, BY, BZ, CA, CH, CL, CN, CO, CR, CU, CZ, DE, DK, DM, DO, DZ, EC, EE, EG, ES, FI, GB, GD, GE, GH, GM, GT, HN,

HR, HU, ID, IL, IN, IS, JP, KE, KG, KM, KN, KP, KR, KZ, LA, LC, LK, LR, LS, LT, LU, LY, MA, MD, ME, MG, MK, MN, MW, MX, MY, MZ, NA, NG, NI, NO, NZ, OM, PE, PG, PH, PL, PT, QA, RO, RS, RU, RW, SC, SD, SE, SG, SK, SL, SM, ST, SV, SY, TH, TJ, TM, TN, TR, TT, TZ, UA, UG, US, UZ, VC, VN, ZA, ZM, ZW.

(84) Designated States (unless otherwise indicated, for every kind of regional protection available): ARIPO (BW, GH, GM, KE, LR, LS, MW, MZ, NA, RW, SD, SL, SZ, TZ, UG, ZM, ZW), Eurasian (AM, AZ, BY, KG, KZ, MD, RU, TJ, TM), European (AL, AT, BE, BG, CH, CY, CZ, DE, DK, EE, ES, FI, FR, GB, GR, HR, HU, IE, IS, IT, LT, LU, LV, MC, MK, MT, NL, NO, PL, PT, RO, RS, SE, SI, SK, SM, TR), OAPI (BF, BJ, CF, CG, CI, CM, GA, GN, GQ, GW, ML, MR, NE, SN, TD, TG).

Declarations under Rule 4.17:

- as to applicant's entitlement to apply for and be granted a patent (Rule 4.17(ii))
- as to the applicant's entitlement to claim the priority of the earlier application (Rule 4.17(iii))

Published:

- with international search report (Art. 21(3))
- before the expiration of the time limit for amending the claims and to be republished in the event of receipt of amendments (Rule 48.2(h))

(88) Date of publication of the international search report:

22 November 2012

(54) Title: BRUSHLESS PM MACHINE CONSTRUCTION ENABLING LOW COERCIVITY MAGNETS

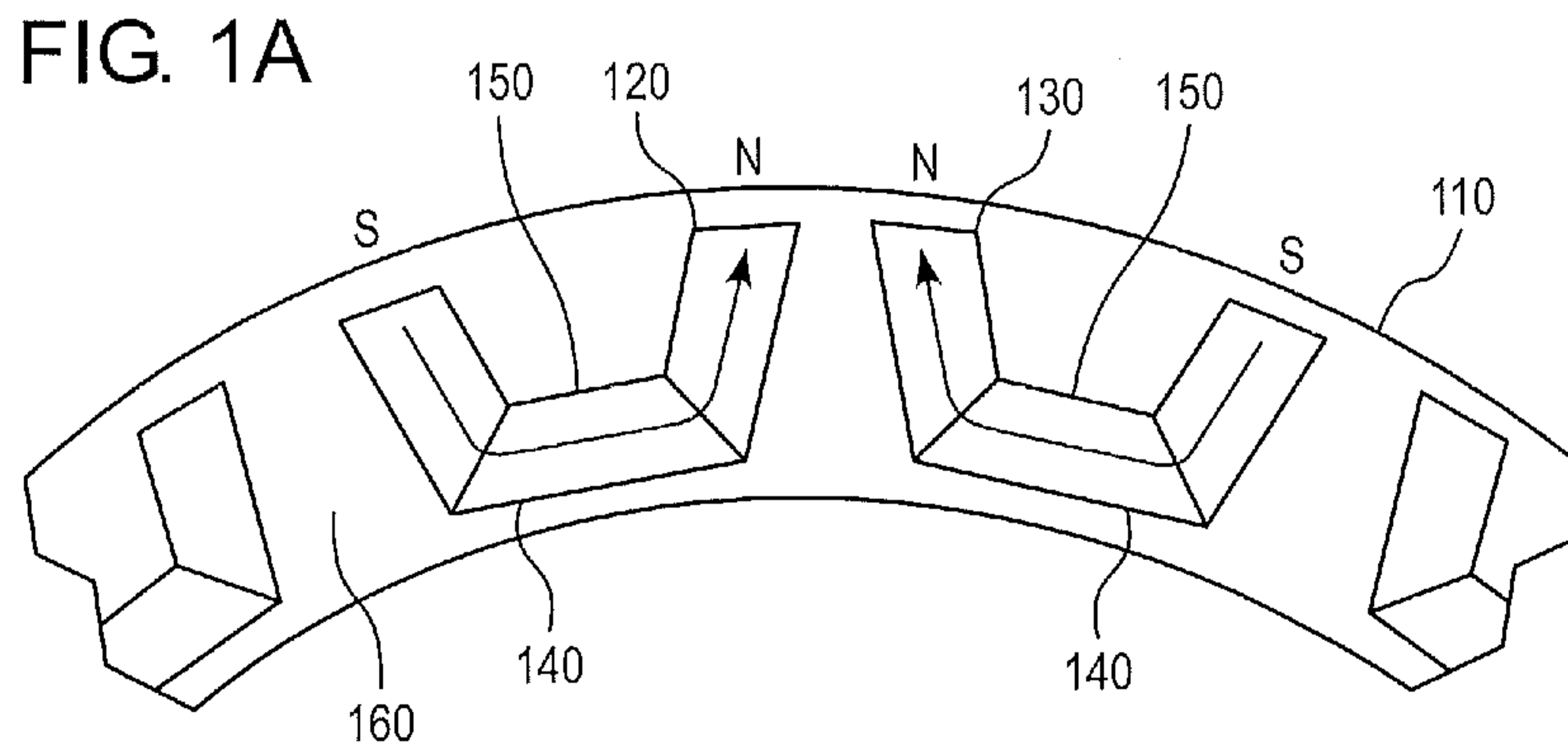

(57) Abstract: The present disclosure provides a brushless permanent magnet machine which includes an essentially circular shaped rotor, and a pair of magnets arranged in the rotor. The magnets are each U-shaped and have a thickness direction extending along a contour of the corresponding magnet between the opposite poles of the corresponding magnet, respectively. The magnets are each composed of a non-rare earth material having a lower coercivity than a rare earth material. A direction of magnetization of each of the pair of magnets is parallel to the thickness direction of the corresponding magnet. The present disclosure also provides a method of manufacturing such a brushless permanent magnet machine.



WO 2012/118787 A3

## BRUSHLESS PM MACHINE CONSTRUCTION ENABLING LOW COERCIVITY MAGNETS

### RELATED APPLICATION

[0001] This application claims the benefit under 35 U.S.C. §119 of U.S.  
5 Provisional Patent No. 61/447,280 filed on February 28, 2011, the entire  
contents of which are hereby incorporated by reference in their entireties.

### FIELD

[0002] The present disclosure relates to the field of brushless machine  
10 architectures. More particularly, the present disclosure relates to an  
architecture or construction of a brushless permanent magnet (PM) machine  
or PM synchronous machine that enables the use of low coercivity magnets,  
such as Aluminum Nickel Cobalt (AlNiCo) or Iron Cobalt Tungsten (FeCoW),  
for example.

15

### BACKGROUND INFORMATION

[0003] Induction machines and wound-field machines are two types of high  
power propulsion technologies that do not rely upon rare earth magnets.  
Both technologies consume power to create their magnetic fields and both  
20 have, to date, been bypassed in favor of permanent magnet machines (e.g.,  
the hybrid automobiles built by Toyota<sup>®</sup>, Honda<sup>®</sup>, GM<sup>®</sup>, Ford<sup>®</sup> and Chrysler<sup>®</sup>,  
the extended-range electric vehicle built by GM<sup>®</sup>, and the electric vehicle  
built by Nissan<sup>®</sup>, all of which being built by the filing date of the present  
disclosure). The PMs incorporated in the aforementioned vehicles utilize  
25 rare earth materials because of the high coercivity of the rare earth  
materials. However, the price of rare-earth materials has proven to be  
volatile, leading to a desire for alternatives to these materials.

**SUMMARY**

- [0004]** Exemplary embodiments of the present disclosure provide a permanent magnet machine with the properties of rare earth machines, without utilizing the rare earth materials. For instance, exemplary
- 5     embodiments of the present disclosure provide a PM machine architecture which can deliver high performance without the use of rare earth permanent magnets. The exemplary PM machine architecture includes a rotor geometry that allows the use of lower energy magnet material, such as AlNiCo and FeCoW, for example. These magnetic materials are not currently adopted
- 10    because of low coercivity when compared to rare earth magnets. This translates into the potential for demagnetization in high power machines, and the material is unusable in current machines due to this limitation. However, the exemplary PM machine architecture of the present disclosure includes a unique geometrical arrangement that keeps the operating flux of
- 15    these magnets at a higher flux density than any other known architecture. By operating near the peak flux density of these magnets (e.g., the residual induction), low coercivity becomes acceptable.
- [0005]** An exemplary embodiment of the present disclosure provides a brushless permanent magnet machine which includes an essentially circular
- 20    shaped rotor, and at least a pair of magnets arranged in the rotor (multiples of two). The term "essentially circular", as used herein, means a degree of variance (e.g., +/- 5%) along the contour of the inner or outer diameter of the rotor due to manufacturing tolerances. Each of the magnets is substantially U-shaped and has a thickness direction extending along a contour of the
- 25    corresponding magnet between the opposite poles of the corresponding magnet, respectively. The magnets are each composed of a non-rare earth material having a lower coercivity than a rare earth material. A direction of magnetization of each of the magnets is parallel to the thickness direction of the corresponding magnet.
- 30    **[0006]** An exemplary embodiment of the present disclosure provides a method of manufacturing a brushless permanent magnet machine. The exemplary method includes arranging the magnets in a rotor that is

essentially circular shaped. The exemplary method also includes forming each of the magnets to be a U-shape with a thickness direction extending along a contour of the corresponding magnet between the opposite poles of the magnet, respectively. In addition, the exemplary method includes  
5 forming each of the pair of magnets to be composed of a non-rare earth material having a lower coercivity than a rare earth material, such that a direction of magnetization of each of the pair of U-shaped magnets is parallel to the thickness direction of the corresponding magnet.

## 10 **BRIEF DESCRIPTION OF THE DRAWINGS**

**[0007]** Additional refinements, advantages and features of the present disclosure are described in more detail below with reference to exemplary embodiments illustrated in the drawings, in which:

**[0008]** Figure 1A illustrates a fragmentary cross-sectional view of a PM  
15 machine construction according to an exemplary embodiment of the present disclosure;

**[0009]** Figure 1B illustrates a fragmentary cross-sectional view of a PM machine construction according to an exemplary embodiment of the present disclosure;

20 **[0010]** Figure 2 illustrates a fragmentary cross-sectional view of a PM machine construction according to an exemplary embodiment of the present disclosure;

**[0011]** Figure 3 illustrates a fragmentary cross-sectional view of a pair of magnets in a PM machine construction according to an exemplary  
25 embodiment of the present disclosure;

**[0012]** Figure 4 illustrates a fragmentary cross-sectional view of a pair of magnets in a PM machine construction according to an exemplary embodiment of the present disclosure according to an exemplary embodiment of the present disclosure;

30 **[0013]** Figures 5a and 5b illustrate a fragmentary cross-sectional view of a PM machine construction according to exemplary embodiments of the present disclosure;

[0014] Figures 6a-c illustrates a fragmentary cross-sectional view of a PM machine construction including retaining rods and caps, according to an exemplary embodiment of the present disclosure;

[0015] Figures 7a and 7b illustrate a fragmentary cross-sectional view of a PM machine construction according to an exemplary embodiment of the present disclosure;

[0016] Figures 8a and 8b illustrate exemplary features to secure the rotor to a motor shaft;

[0017] Figure 9 illustrates a graph showing a permeance coefficient of a PM machine according to an exemplary embodiment of the present disclosure, and a permeance coefficient of a known PM machine; and

[0018] Figure 10 illustrates a flux plot showing a magnetic direction extending a direction of thickness of a PM machine according to an exemplary embodiment of the present disclosure.

[0019] In the drawings, similar components or similarly-functioning components are denoted with the same reference number. Various features depicted in the drawings are not drawn to scale for better understanding of the features of the present disclosure.

## 20 DETAILED DESCRIPTION

[0020] Figure 1A illustrates a fragmentary cross-sectional view of a PM machine construction according to an exemplary embodiment of the present disclosure. Figure 1A contains a partial view of a permanent magnet rotor 110 (rotor core) that is rotatably mounted on a motor shaft. The permanent magnet rotor 210 is essentially circularly shaped. The motor shaft is arranged inside of the inner circumference of the rotor 110, and a stator is arranged around or in proximity to the outer circumference of the rotor 110. The motor shaft and stator are known and are therefore not illustrated.

[0021] The fragmentary view of Figure 1A illustrates a pair of magnets 120, 130 arranged in the rotor 110. According to an exemplary embodiment, a plurality of pairs of magnets 120, 130 extend throughout the rotor core 110, such that a plurality of pairs of magnets 120, 130 are contained

throughout the essentially circular shape of the rotor 110. In the exemplary embodiment illustrated in Figure 1A, the pair of magnets 120, 130 are arranged adjacent to each other along the circumference of the rotor 210. Each of the magnets 120, 130 has a U-shaped configuration having a

5 radially inward side 140 on the side of the magnet pointing in the direction of the motor shaft, and a radially outward side 150 on the side of the magnet pointing in the direction of the stator. Surrounding each pair of magnets 120, 130 in the rotor core is a low-permeability, low-resistivity material 160. In the exemplary configuration of Figure 1A, the pair of magnets 120, 130 are

10 adjacent to each other along the contour of the rotor 110, but the material 160 is disposed between the magnets 120, 130. However, the present disclosure is not limited to this configuration, as will be illustrated in exemplary embodiments described below. As used herein, a low-

permeability, low-resistivity material means any material which has low-

15 conductivity and is non-ferromagnetic. Examples of such materials include plastics, epoxies, polymers, fiberglass, carbon fiber, etc. The present disclosure is not limited to these examples. The material 160 provides a nonmagnetic support structure to eliminate flux leakage and to eliminate the need for rotor magnetic back-iron due to the magnetization direction of the

20 pair of magnets 120, 130.

**[0022]** As illustrated in the exemplary embodiment of Figure 1A, the pair of magnets 120, 130 have a common pole on the sides of the magnets 120, 130 which are adjacent to each other, such that the poles of the pair of magnets 120, 130 are the same on the respective portions of the pair of

25 magnets 120, 130 which are adjacent to each other. Accordingly, the pair of magnets 120, 130 have an oppositely arranged polarity with respect to each other. For instance, in the example of Figure 1A, the left magnet 120 has a south (S) pole on the left side of the U-shaped magnet 120 and a north (N) pole on the right side of the U-shaped magnet 120. Conversely, the right

30 magnet 130 has a S pole on the right side of the U-shaped magnet 130, and a N pole on the left side of the U-shaped magnet 130. The present disclosure is not limited to the designation of poles utilized in Figure 1A. For

instance, the polarities of the pair of magnets 120, 130 can be reversed, provided that the sides of the pair of magnets 120, 130 which are adjacent to each other have the same poles.

**[0023]** Each of the pair of magnets 120, 130 has a thickness direction  
5 extending along the contour of the corresponding magnet between the opposite poles of the corresponding magnet, respectively. The arrows illustrated in Figure 1A represent the respective thickness directions and magnetization directions of the pair of magnets 120, 130.

**[0024]** The permanent magnets (e.g., magnets 120, 130) are low coercivity  
10 magnets, such as AlNiCo or FeCoW, for example. These materials are considered to be non-rare earth materials, in contrast to the materials used in manufacturing known PMs. Known PM techniques utilize rare earth materials for the magnets, such as Neodymium Iron Boron (NdFeB) and Samarium Cobalt (SmCo), for example. By utilizing such low coercivity  
15 magnets, the permanent magnets (e.g., 120, 130) of the present disclosure each have a direction of magnetization that is parallel to the direction of thickness of the thickness direction of the corresponding magnet.

Accordingly, with reference to the exemplary embodiment of Figure 1A, the directions of magnetization of the pair of magnets 120, 130 are shown by the  
20 respective arrows. Therefore, the direction of magnetization of magnet 120 is parallel to the thickness direction of magnet 120 represented by the arrow extending from the south pole to the north pole in magnet 130. Similarly, the direction of magnetization of magnet 130 is parallel to the thickness direction of magnet 130 represented by the arrow extending from the south pole to  
25 the north pole in magnet 130.

**[0025]** Therefore, the direction of magnetization of magnets 120, 130 is different than the direction of magnetization of known PM machines utilizing rare earth materials as the material of the magnets. This is because the direction of magnetization in known permanent magnets utilizing rare earth  
30 materials is normal (e.g., perpendicular) to the thickness direction of the corresponding magnet.

**[0026]** In the exemplary embodiment illustrated in Figure 1A, the pair of magnets 120, 130 are each respectively illustrated as a continuous and/or joined structure. The present disclosure is not limited thereto. For instance, one or more of the magnets 120, 130 in any corresponding pair of magnets  
5 in the rotor 110 may be segmented into multiple cross-sectional pieces of the corresponding magnet. For example, as illustrated in Figure 1B, magnets 120, 130 are each respectively composed of three separate trapezoidal pieces (i) 122, 132, (ii) 124, 134, (iii) 126, 136 that are, similar to Figure 1A, magnetized parallel to the thickness of the respective magnets. The  
10 magnets in the pair do not have to be segmented in the same number of cross-sectional pieces as each other. For example, magnet 120 could be segmented in two pieces (e.g., (i) 122 and (ii) 124 joined to or made continuous with 126), while magnet 130 is segmented into three pieces (e.g., (i) 132, (ii) 134 and (iii) 136). Furthermore, one of the magnets of the pair  
15 may be continuous and/or joined as illustrated in Figure 1A, while the other magnet of the pair can be segmented into two or more pieces, as illustrated in Figure 1B. It is important to note that despite whether one or more of the magnets in the corresponding pair is continuous and/or joined together or segmented into multiple separate pieces, each of the magnets of the  
20 corresponding pair is magnetized parallel to the thickness of the respective magnets in the pair.

**[0027]** Figure 2 illustrates a fragmentary cross-sectional view of a PM machine construction according to an exemplary embodiment of the present disclosure. The exemplary embodiment illustrated in Figure 2 presents a  
25 modification to the exemplary embodiment illustrated in Figure 1A. In particular, the contour of the pair of U-shaped magnets 220, 230 is more rounded than the contour of the U-shaped permanent magnets 120, 130 illustrated in Figure 1A. However, the same effects are achieved in the permanent magnets illustrated in Figure 2 as in Figures 1A and 1B. For  
30 instance, each of the pair of magnets 120, 130 in Figure 2 has a direction of magnetization parallel to the thickness direction of the corresponding magnet due to the utilization of a low coercivity material for the magnet, such as

AlNiCo and FeCoW, for example, and the U-shaped configuration of the magnets.

**[0028]** Figures 3 and 4 illustrate fragmentary cross-sectional views of a pair of magnets in a PM construction according to exemplary embodiments of the present disclosure. Figure 3 illustrates a modification of the exemplary configurations of Figures 1A and 1B, while Figure 4 illustrates a modification of the exemplary configuration of Figure 2. In the exemplary embodiment of Figure 3, a soft magnetic material 370 replaces the low permeability, low resistivity material 160 above the sides of the pair of magnets 320, 330 which are adjacent to each other. The remaining portions of the magnets 320, 330 are constituted by the hard non-rare earth material AlNiCo and FeCoW, for example. The magnetic material 370 serves as an N pole for the magnets 320, 330 in the example of Figure 3. The material 160 fills the remaining portions of the rotor not occupied by the magnets 320, 330 and the magnetic material 370. Similarly, in the example of Figure 4, the soft magnetic material 470 serves as the N pole for the hard non-rare earth pair of magnets 420, 430 having a rounder U-shape. The magnetic material 370, 470 in the examples of Figures 3 and 4 may be constituted by a material such as iron, silicon-steel and nickel-iron, or alloys thereof, for example. In the examples of Figure 3 and 4, the same effects are achieved in the permanent magnets illustrated in Figure 3 and 4 as in the above-described exemplary embodiments. For instance, each of the corresponding pair of magnets 320, 330 and 420, 430 in Figures 3 and 4 has a direction of magnetization parallel to the thickness direction of the corresponding magnet due to the utilization of a low coercivity material for the magnet, such as AlNiCo and FeCoW, for example, and the U-shaped configuration of the magnets.

**[0029]** Figures 5a and 5b illustrate fragmentary cross-sectional views of a PM construction according to exemplary embodiments of the present disclosure. In the exemplary embodiment illustrated in Figures 1A and 1B, for example, it was described that the material 160 separates the adjacent pair of magnets 120, 130. The present disclosure is not limited thereto. For

example, as illustrated in Figures 5a and 5b, non-magnetic retainers 580 can be provided in the inner concave of the U-shaped pair of magnets 520, 530 to secure the magnets 520, 530 in place in the rotor 510. The retainers 580 provided in the inner concave of the U-shaped pair of magnets 520, 530 is  
5 any type of non-magnetic material with low permeability, such as aluminum bar, brass bar, stainless steel, titanium, carbon fiber, etc. While the retainers 580 are non-magnetic, they do not need to be non-conductive. Accordingly, the retainers 580 can serve to secure the pair of magnets 520, 530 constituted by the hard non-rare earth material AlNiCo and FeCoW, for  
10 example, in place, and thereby avoid the use of the material 160 in the rotor 510, if all corresponding pairs of magnets 520, 530 are intended to be secured to each other. As illustrated in Figure 5a, it is not necessary for the retainers 580 to be flush with the outer circumference of the rotor 510.

**[0030]** Figure 5b illustrates another exemplary embodiment in which  
15 securing mechanisms can be provided to secure the pair of magnets 520, 530 to each other. In the example of Figure 5b, male and female mating tabs 590 can be provided in the U-shaped magnets 520, 530 to secure the magnets to each other in the rotor 510. The tabs 590 can be utilized in addition to or as an alternative to the retainers 580. In the example  
20 illustrated in Figure 5b, both the retainers 580 and tabs 590 are provided. It is to be noted that in the example of Figure 5a, the retainers 580 were not flush with the outer circumference of the rotor 510, while in the example of Figure 5b they are. The present disclosure is also not limited to the illustrated types of retainers 580 and tabs 590 as illustrated in the examples  
25 of Figures 5a and 5b. For example, any male extension components and corresponding female receiving components can be utilized to secure the pair of magnets to each other. In the examples of Figure 5a and 5b, the same effects are achieved in the permanent magnets illustrated in Figure 5a and 5b as in the above-described exemplary embodiments. For instance,  
30 each of the corresponding pair of magnets 520, 530 in Figures 5a and 5b has a direction of magnetization parallel to the thickness direction of the corresponding magnet due to the utilization of a low coercivity material for

the magnet, such as AlNiCo and FeCoW, for example, and the U-shaped configuration of the magnets.

**[0031]** Figures 6a-6c illustrate another exemplary embodiment in which retaining rods are used to secure each corresponding pair of magnets 620, 630 arranged in the rotor 610 in the place. As illustrated in Figure 6a, retaining rods 650 are arranged in the concave portion of the U-shaped pair of magnets 620, 630 to secure the magnets 620, 630 in place. According to an exemplary embodiment, the retaining rods 650 can be provided in one or more of the U-shaped pair of magnets 620, 630 contained in the rotor 610. As illustrated in Figure 6b, the retaining rods 650 extend out from the inner and/or outer cross-sectional surface of the rotor. Therefore, as illustrated in Figure 6c, a cap 660 with corresponding mating inserts can be used to engage with the retaining rods 650 on the front and/or backside surface of the rotor 610 and thereby secure the pair(s) of U-shaped magnets 620, 630 in place. In addition, the magnets in the exemplary embodiment of Figures 6a-6c may also include interlocking features as illustrated in Figure 5b. In the examples of Figures 6a-c, the same effects are achieved in the permanent magnets illustrated in Figures 6a-6c as in the above-described exemplary embodiments. For instance, each of the corresponding pair of magnets 620, 630 in Figures 6a-c has a direction of magnetization parallel to the thickness direction of the corresponding magnet due to the utilization of a low coercivity material for the magnet, such as AlNiCo and FeCoW, for example, and the U-shaped configuration of the magnets.

**[0032]** Figures 7a and 7b illustrate another exemplary embodiment of the present disclosure in which there is a non-uniform outer diameter, where the area at the interface 780 between the magnets 720, 730 forms a larger rotor assembly diameter than the area adjacent to this interface. Figure 7a illustrates the situation in which the pair of magnets 720, 730 are physically in contact, while Figure 7b illustrates the situation where the pair of magnets 720, 730 are not physically in contact. The non-uniform outer diameter illustrated in Figures 7a and 7b can apply to any of the above-described exemplary embodiments. In the examples of Figures 7a and 7b, the same

effects are achieved in the permanent magnets illustrated in Figures 7a and 7b as in the above-described exemplary embodiments. For instance, each of the corresponding pair of magnets 720, 730 in Figures 7a and 7b has a direction of magnetization parallel to the thickness direction of the  
5 corresponding magnet due to the utilization of a low coercivity material for the magnet, such as AlNiCo and FeCoW, for example, and the U-shaped configuration of the magnets.

**[0033]** Figures 8a and 8b illustrate another exemplary embodiment in which there is a non-uniform inner diameter of the rotor 810 engage the  
10 motor shaft. For instance, as illustrated in Figure 8a, there may be provided tabs 840 on the inner surface of the rotor 810 to receive corresponding protruding engagement parts provided on the outer surface of the motor shafts. On the other hand, as illustrated in Figure 8b, there may be provided protruding extension components 850 to be mated with corresponding  
15 receiving components on the surface of the motor shaft.

**[0034]** Features of any of the exemplary embodiments described above can be combined as it is deemed advantageous.

**[0035]** Figure 9 illustrates a graph showing a permeance coefficient of a PM machine according to the exemplary embodiments of the present  
20 disclosure, and a permeance coefficient of a known PM machine. As described above, the aforementioned exemplary embodiments provide an architecture of a brushless machine, where the architecture includes the following features:

- a U-shaped magnet magnetized along the contour (tangentially)  
25 rather than through the thickness (normally); and
- a nonmagnetic support structure to eliminate flux leakage and to eliminate the need for rotor magnetic back-iron due to the magnetization direction.

In developing this architecture, permanent magnet technologies that can  
30 support high air-gap flux densities were first identified. This led to a close look at aluminum-nickel-cobalt (AlNiCo) chemistry, which has a high residual

induction flux density (see Figure 9). The flux density of an AlNiCo magnet is over 13 kilogauss (1.3 Tesla), rivaling an NdFeB magnet. Generally, a NdFeB magnet with sufficient temperature capability has a maximum flux density of 1.1 to 1.2 Tesla, which is lower than a high flux AlNiCo magnet.

5 The challenge and reason that the AlNiCo magnet is not used in electric propulsion motors is the low coercivity (x-axis parameter). This means that the AlNiCo magnet is easy to demagnetize when placed in the magnetic circuit and exposed to fields created by stator armature currents. In a traditional permanent magnet motor, this particular magnet would

10 demagnetize to less than 20% flux, leading to an unacceptable 80% drop in motor torque. On the contrary, the exemplary PM machine architecture of the present disclosure keeps the operating point near the residual induction, above the "knee" of the curve of Figure 9 so that no demagnetization occurs. At zero load conditions, the attribute that describes this operating point is the

15 permeance coefficient. The permeance coefficient of a traditional permanent magnet motor architecture, either surface-mounted or embedded, is approximately two or three (see the "Typical Motor" load line of Figure 9). The permeance coefficient of the permanent magnet of the present disclosure is approximately twenty (see the "Present Disclosure" load line of

20 Figure 9). This is the first key to the approach.

**[0036]** The following describes a permeance coefficient comparison with respect to Figure 10. This change in operating point occurs due to the innovative rotor geometry and magnetization direction of the magnet. By implementing a curved shape that is magnetized along the tangential

25 direction, the "magnetic thickness" extends from one pole face to the adjacent pole face for a total length that creates this high permeance coefficient. Figure 10 shows an example of a magnetic circuit that makes this possible. ANSYS finite element analysis was used to design and confirm this attribute. ANSYS is a tool used to design and analyze electric

30 machines and has proven to accurately simulate magnetic circuits. The flux plot shows how the magnetic thickness extends from one pole face to the

adjacent and opposite pole face, and combined with a typical magnetic air-gap, creates a high permeance coefficient unique to this architecture.

The exemplary PM machine architecture of the present disclosure includes a nonmagnetic rotor support structure, which replaces traditional laminations.

5 The nonmagnetic rotor support structure eliminates flux leakage that would render the design ineffective and also decreases the amount of armature reaction (stator magnetic field magnitude) that would act to demagnetize the permanent magnets. All of the rotor flux created by the permanent magnets flows through the magnet, from one pole face to the next, which is why a  
10 nonmagnetic rotor is advantageous.

**[0037]** It will be apparent to one skilled in the art that the architecture of the PM machine or PM synchronous machine as described in the exemplary embodiments above can be used in a number of different, beneficial applications. For example, the exemplary embodiments described above  
15 can be utilized in motor and generator applications, among others.

**[0038]** While the present disclosure has been illustrated and described in detail in the drawings and foregoing description, such illustration and description are to be considered illustrative or exemplary and not restrictive. The present disclosure is not limited to the disclosed embodiments. Other  
20 variations to the disclosed embodiments can be understood and effected by those skilled in the art in practicing the claimed invention, from a study of the drawings, the disclosure, and the appended claims. In the claims, the word "comprising" does not exclude other elements or steps, and the indefinite article "a" or "an" does not exclude a plurality. The mere fact that certain  
25 measures are recited in mutually different dependent claims does not indicate that a combination of these measures cannot be used to advantage. Any reference signs in the claims should not be construed as limiting the scope.

**[0039]** Thus, it will be appreciated by those skilled in the art that the  
30 present invention can be embodied in other specific forms without departing from the spirit or essential characteristics thereof. The presently disclosed embodiments are therefore considered in all respects to be illustrative and

not restricted. The scope of the invention is indicated by the appended claims rather than the foregoing description and all changes that come within the meaning and range and equivalence thereof are intended to be embraced therein.

## WHAT IS CLAIMED IS:

1. A brushless permanent magnet machine comprising:  
a rotor that is essentially circular shaped;  
5 a pair of magnets arranged in the rotor, the pair of magnets each being U-shaped and having a thickness direction extending along a contour of the corresponding magnet between the opposite poles of the corresponding magnet, respectively,  
wherein the pair of magnets are each composed of a non-rare earth  
10 material having a lower coercivity than a rare earth material, and  
wherein a direction of magnetization of each of the pair of magnets is parallel to the thickness direction of the corresponding magnet.
2. The brushless permanent magnet machine according to claim  
15 1,  
wherein the pair of magnets are adjacent to each other in the rotor and have opposite polarities such that sides of the pair of magnets immediately adjacent to each other have the same polarity, and  
wherein the direction of magnetization of each of the pair of magnets  
20 is toward the sides of the magnets which are immediately adjacent to each other.
3. The brushless permanent magnet machine according to claim  
1, wherein the non-rare earth material having a lower coercivity than a rare  
25 earth material is one of Aluminum Nickel Cobalt (AlNiCo) and Iron Cobalt Tungsten (FeCoW).
4. The brushless permanent magnet machine according to claim  
1, wherein the pair of magnets are surrounded by a material having low  
30 permeability and low resistivity.

5. The brushless permanent magnet machine according to claim 4, wherein the material having low permeability and low resistivity has low conductivity and is non-ferromagnetic.
- 5 6. The brushless permanent magnet machine according to claim 5, wherein the material having low permeability and low resistivity is selected from the group consisting of plastics, epoxies, polymers, fiberglass, and carbon fiber.
- 10 7. The brushless permanent magnet machine according to claim 1, wherein the pole faces of the magnets in the pair are connected by a soft magnetic material in the rotor.
- 15 8. The brushless permanent magnet machine according to claim 7, wherein the soft magnetic material is constituted by a material selected from the group consisting of iron, silicon-steel, and nickel-iron.
- 20 9. The brushless permanent magnet machine according to claim 1, comprising:  
a plurality of retainers respectively arranged in a corresponding one of each concave portion of the U-shaped magnets to secure the pair of magnets in the rotor.
- 25 10. The brushless permanent magnet machine according to claim 9, wherein the retainers are non-magnetic.
- 30 11. The brushless permanent magnet machine according to claim 1, comprising:  
an extension component in one of the magnets of the pair and a mating receiving component in the other one of the magnets of the pair to receive the extension component of the one of the magnets.

12. The brushless permanent magnet machine according to claim 1, comprising:

a plurality of retaining rods provided in a corresponding one of a concave portion of the U-shaped pair of magnets; and

5 a cap having receiving components corresponding to the retaining rods,

wherein the cap is configured to be secured with the retaining rods to secure the rotor.

10 13. The brushless permanent magnet machine according to claim 1, wherein the rotor has a non-uniform diameter at a portion of the rotor in which the pair of magnets interface.

14. The brushless permanent magnet machine according to claim 15 1, wherein at least one of the magnets in the pair is constituted by a continuous structure between opposite poles of the at least one magnet.

15. The brushless permanent magnet machine according to claim 1, wherein at least one of the magnets in the pair is segmented into at least 20 two separate pieces.

16. A method of manufacturing a brushless permanent magnet machine, comprising:

25 arranging a pair of a magnets in a rotor that is essentially circular shaped;

forming each of the pair of magnets to be a U-shape with a thickness direction extending along a contour of the corresponding magnet between the opposite poles of the magnet, respectively; and

30 forming each of the pair of magnets to be composed of a non-rare earth material having a lower coercivity than a rare earth material, such that a direction of magnetization of each of the pair of U-shaped magnets is parallel to the thickness direction of the corresponding magnet.

17. The method of manufacturing a brushless permanent magnet machine according to claim 16, comprising:

arranging the pair of magnets to be adjacent to each other in the rotor  
5 and have opposite polarities such that sides of the pair of magnet immediately adjacent to each other have the same polarity and the direction of magnetization is toward the sides of the magnets which are immediately adjacent to each other.

10 18. The method of manufacturing a brushless permanent magnet machine according to claim 16, wherein the non-rare earth materials having a lower coercivity than a rare earth material is one of Aluminum Nickel Cobalt (AlNiCo) and Iron Cobalt Tungsten (FeCoW).

15 19. The method of manufacturing a brushless permanent magnet machine according to claim 16, comprising:

surrounding the pair of magnets in the rotor by a material having low permeability and low resistivity.

20 20. The method of manufacturing a brushless permanent magnet machine according to claim 16, comprising:

connecting the pole faces of each of the pair of magnets by a soft magnetic material in the rotor.

25 21. The method of manufacturing a brushless permanent magnet machine according to claim 16, comprising:

arranging a plurality of retainers respectively in a corresponding one of each concave portion of the U-shaped magnets to secure pair of magnets in the rotor.

30

22. The method of manufacturing a brushless permanent magnet machine according to claim 16, comprising:

arranging a plurality of retaining rods in a corresponding one of a concave portion of the U-shaped pair of magnets; and  
securing a cap having receiving components corresponding to the retaining rods to the retaining rods.

FIG. 1A

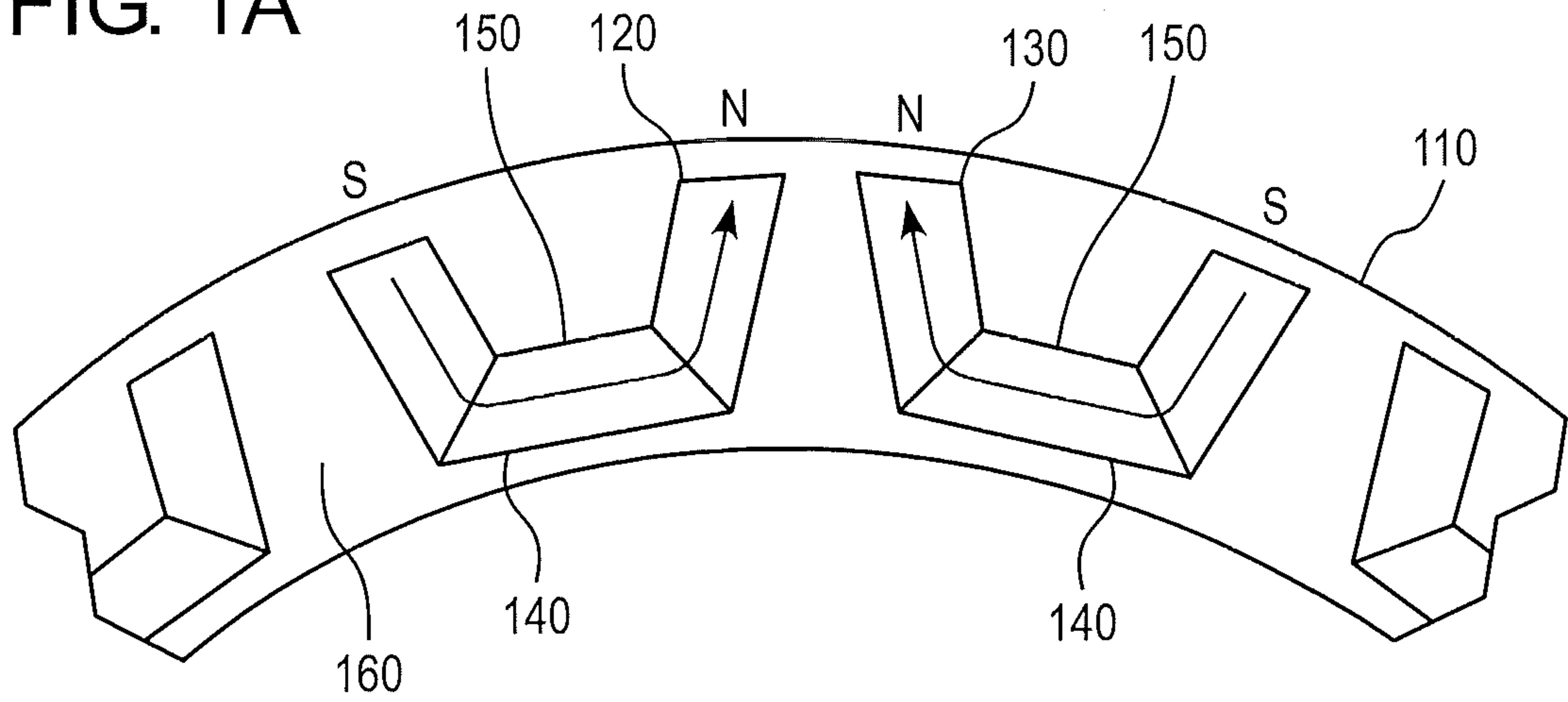

FIG. 1B

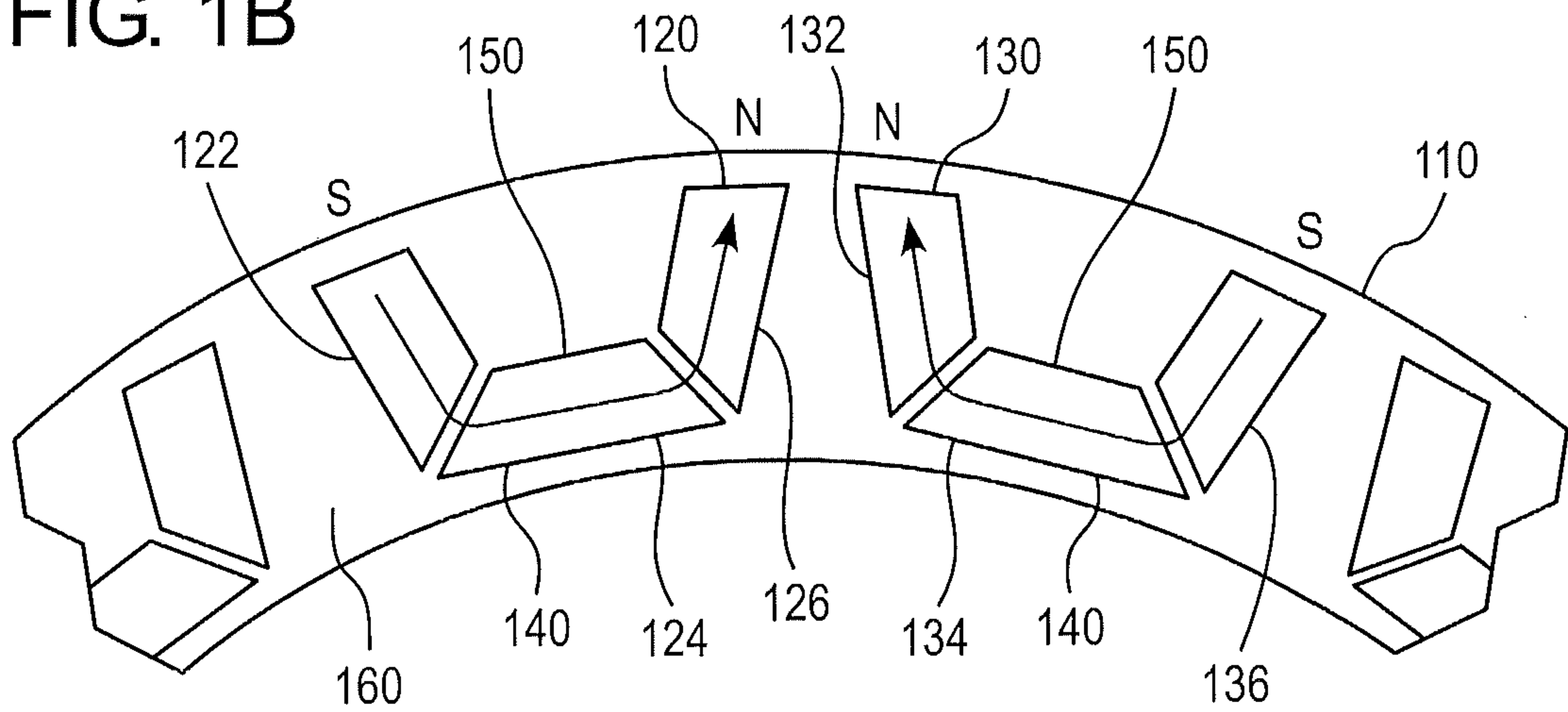

FIG. 2

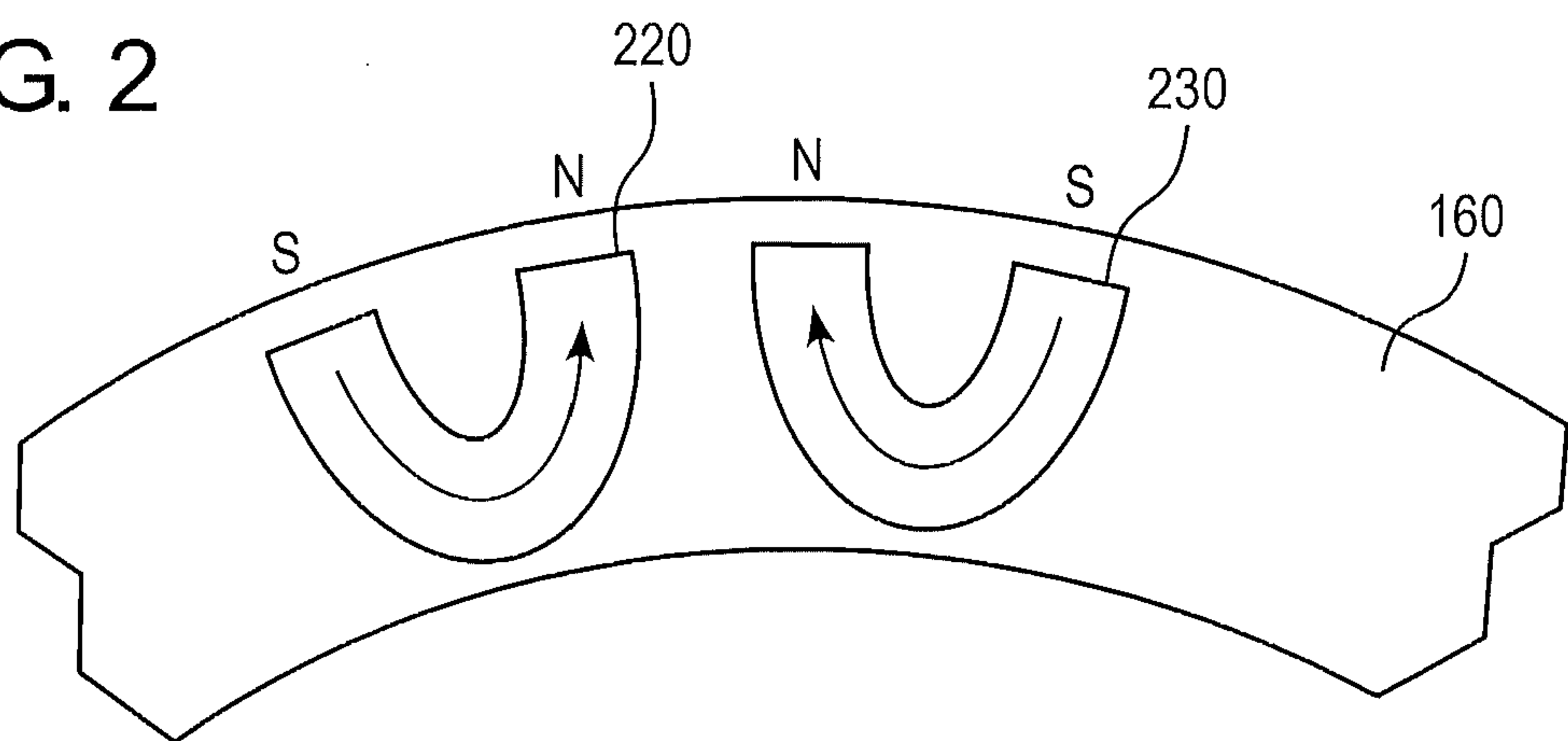

FIG. 3

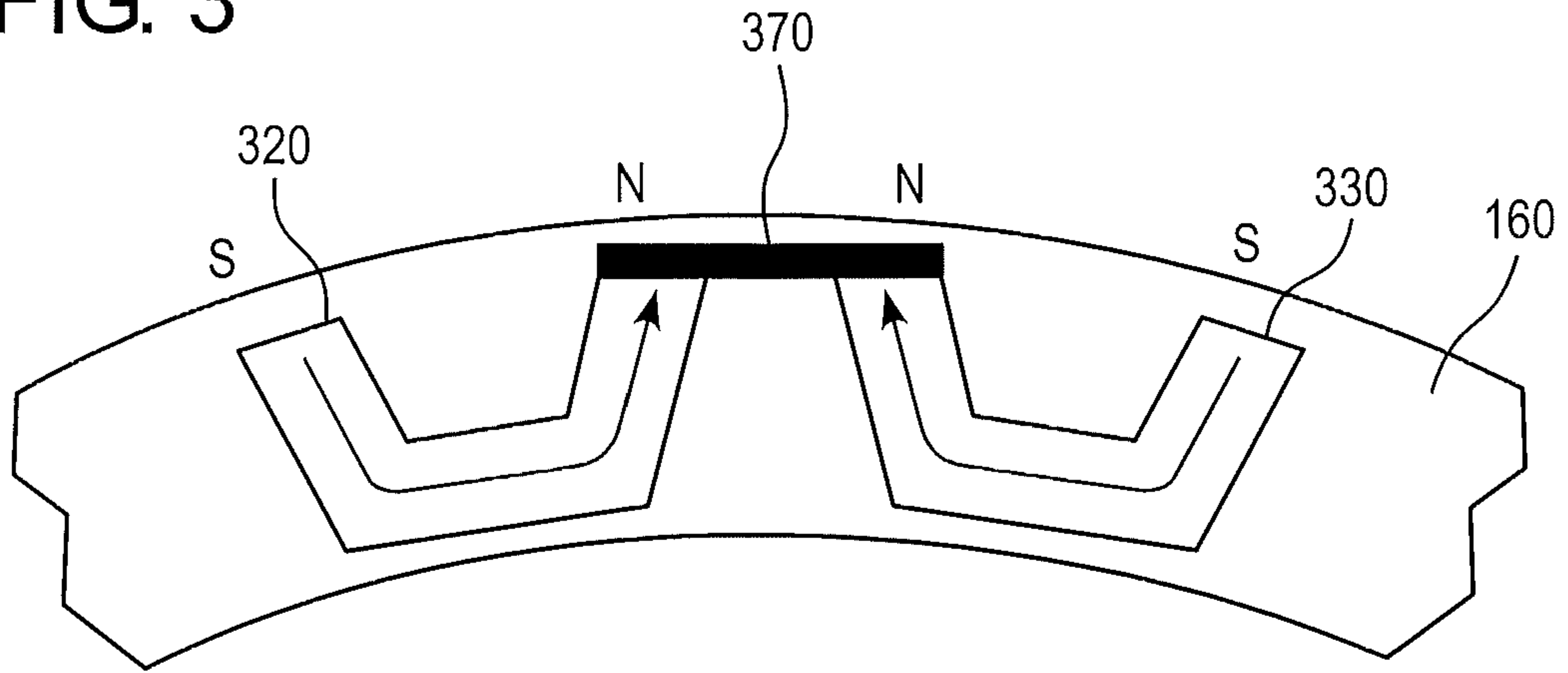

FIG. 4

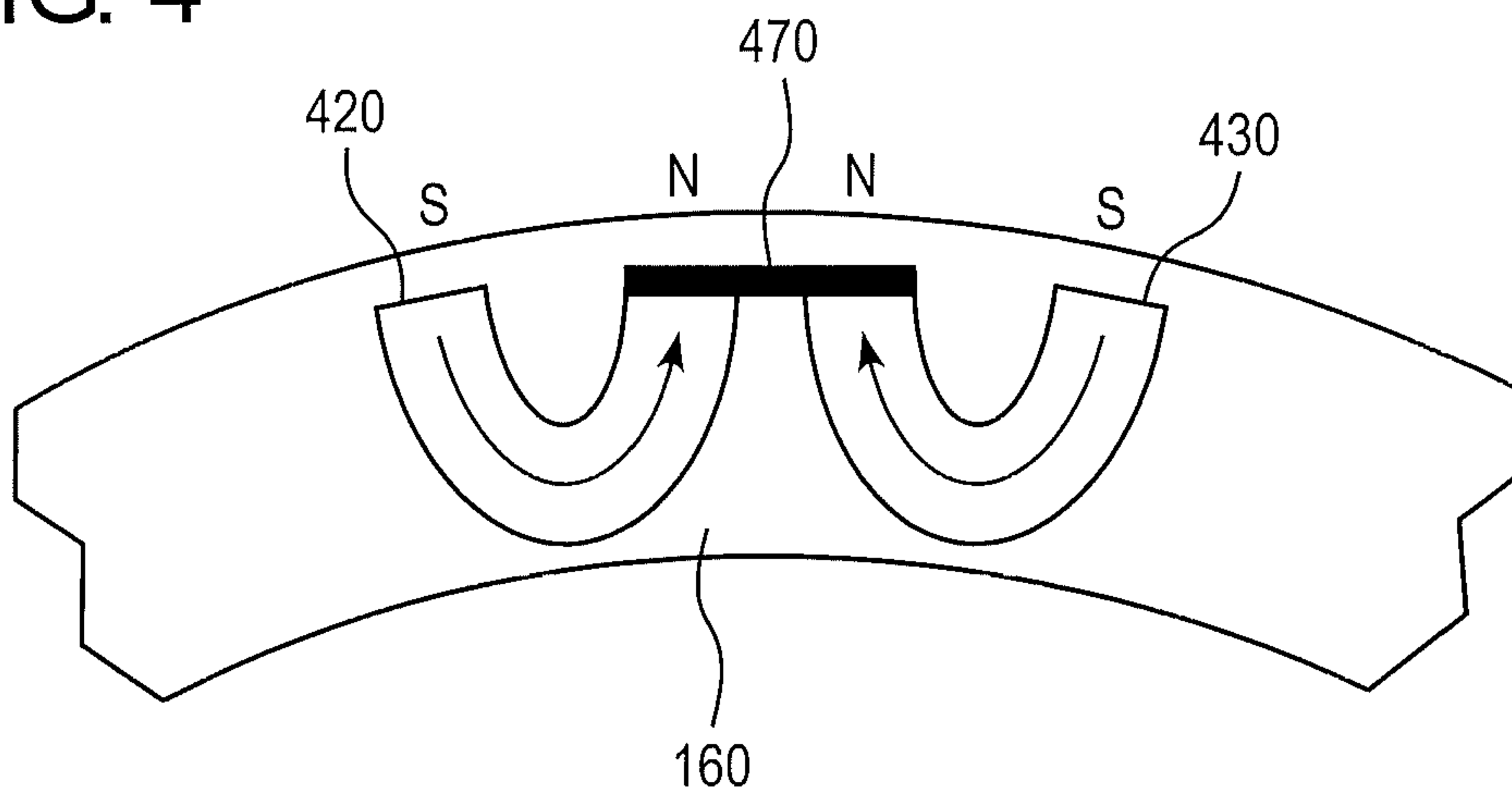

FIG. 5A

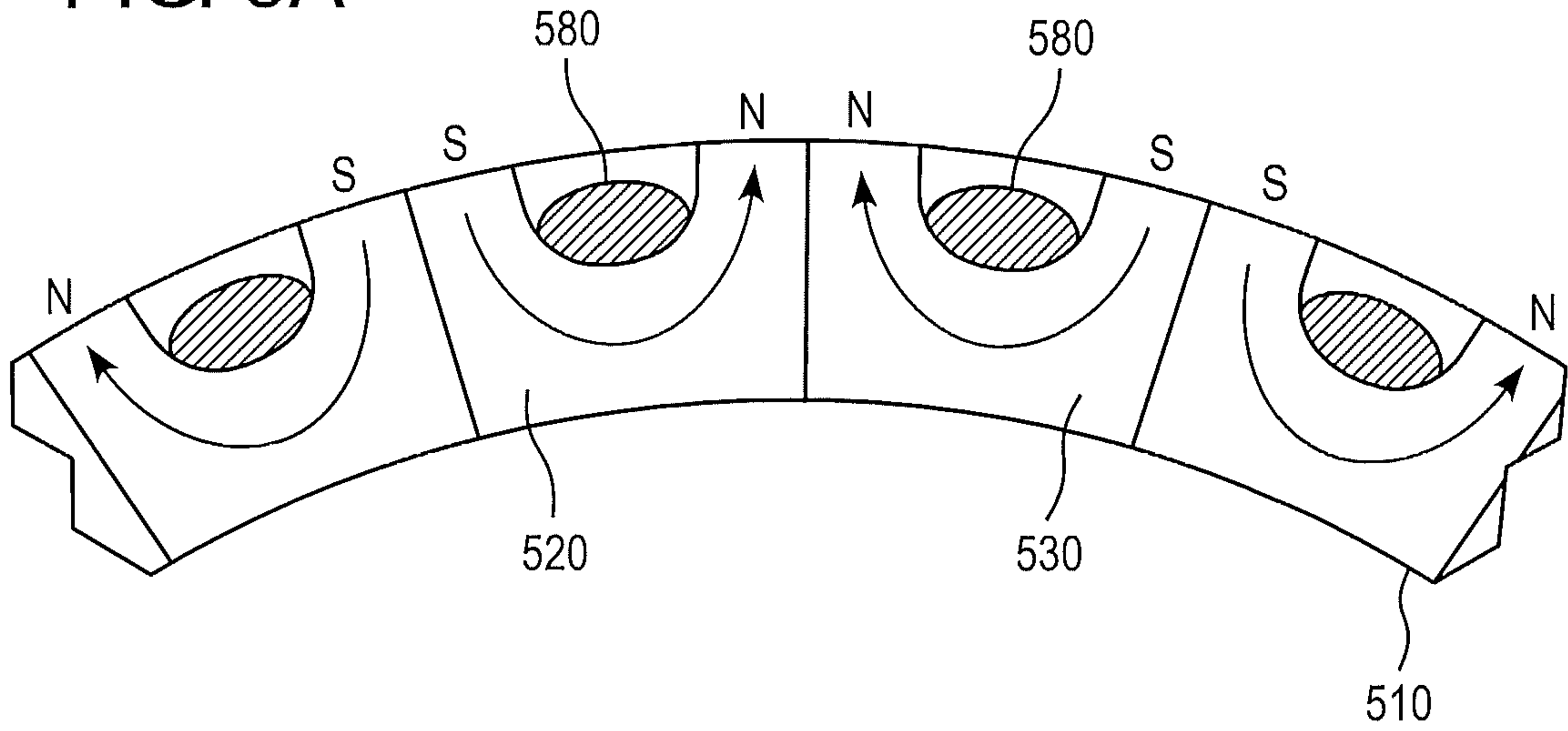

FIG. 5B

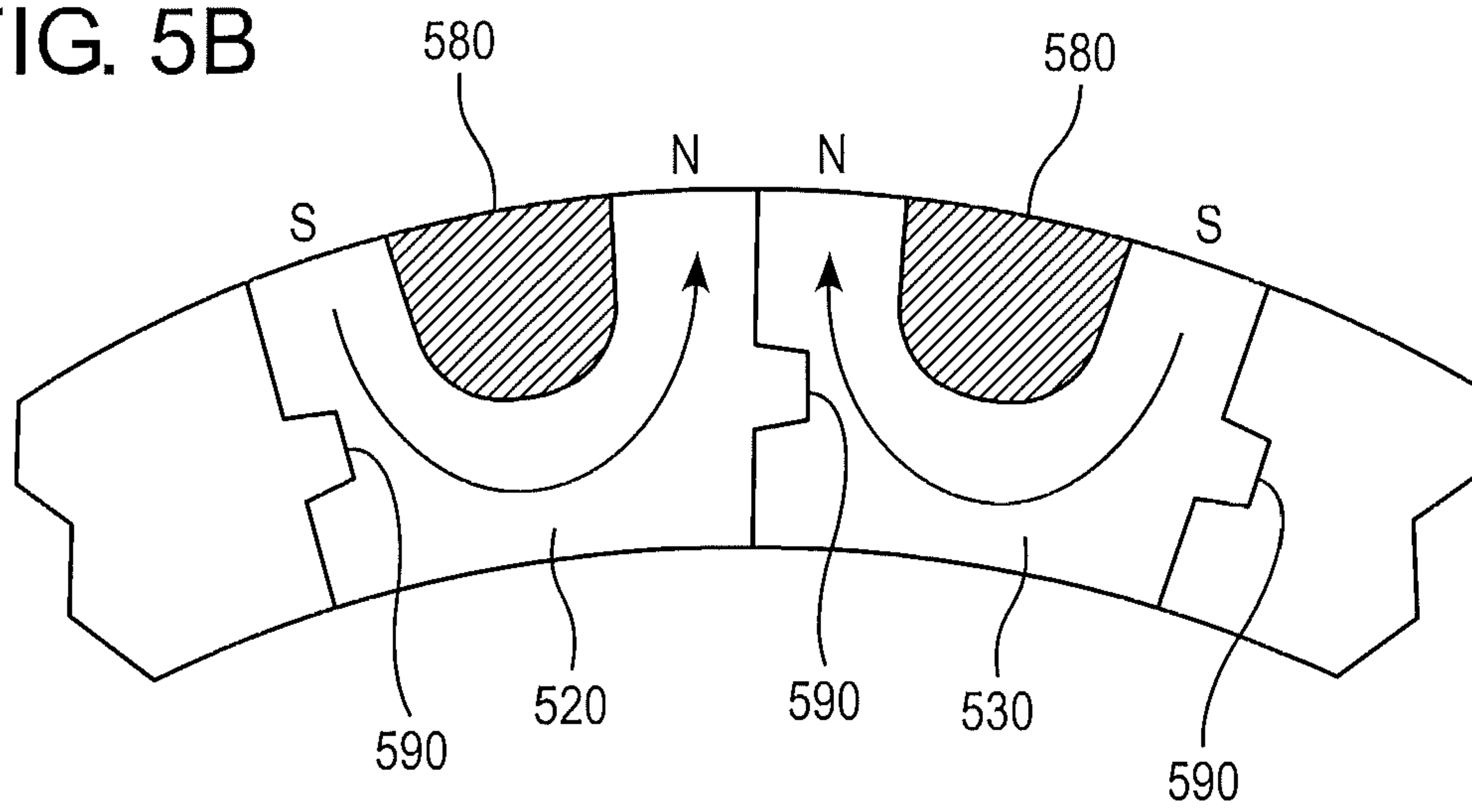

FIG. 6A

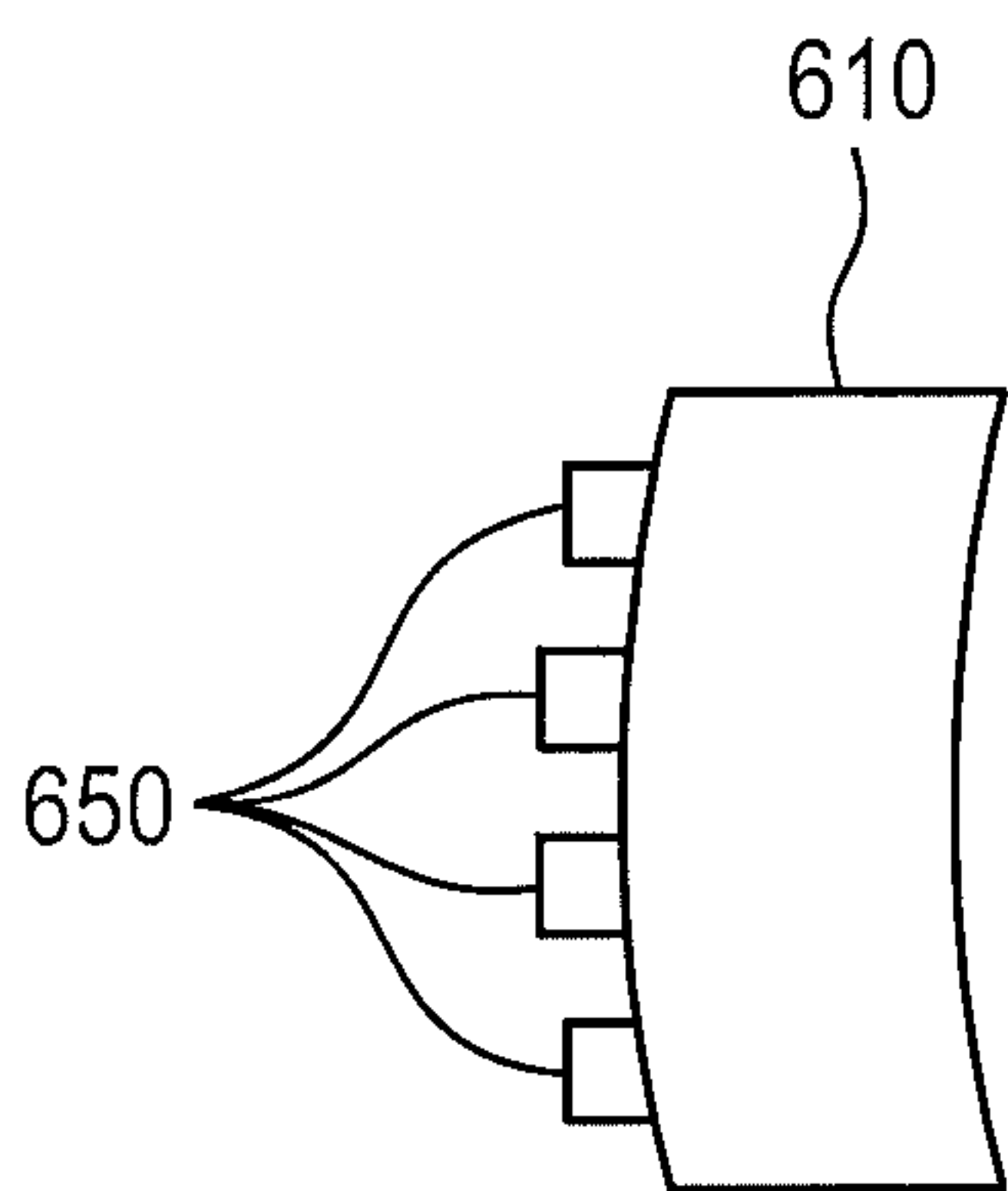
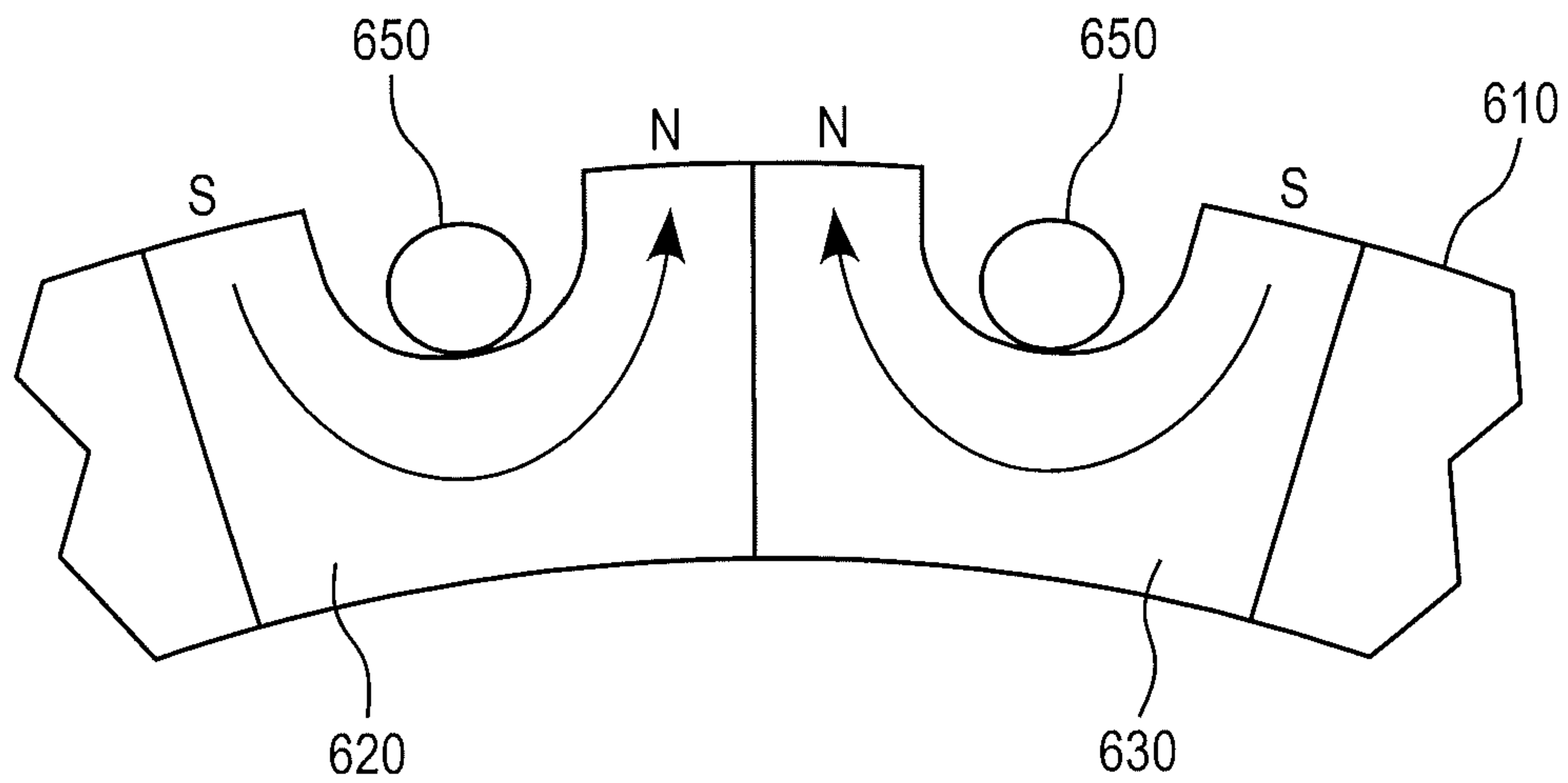

FIG. 6B

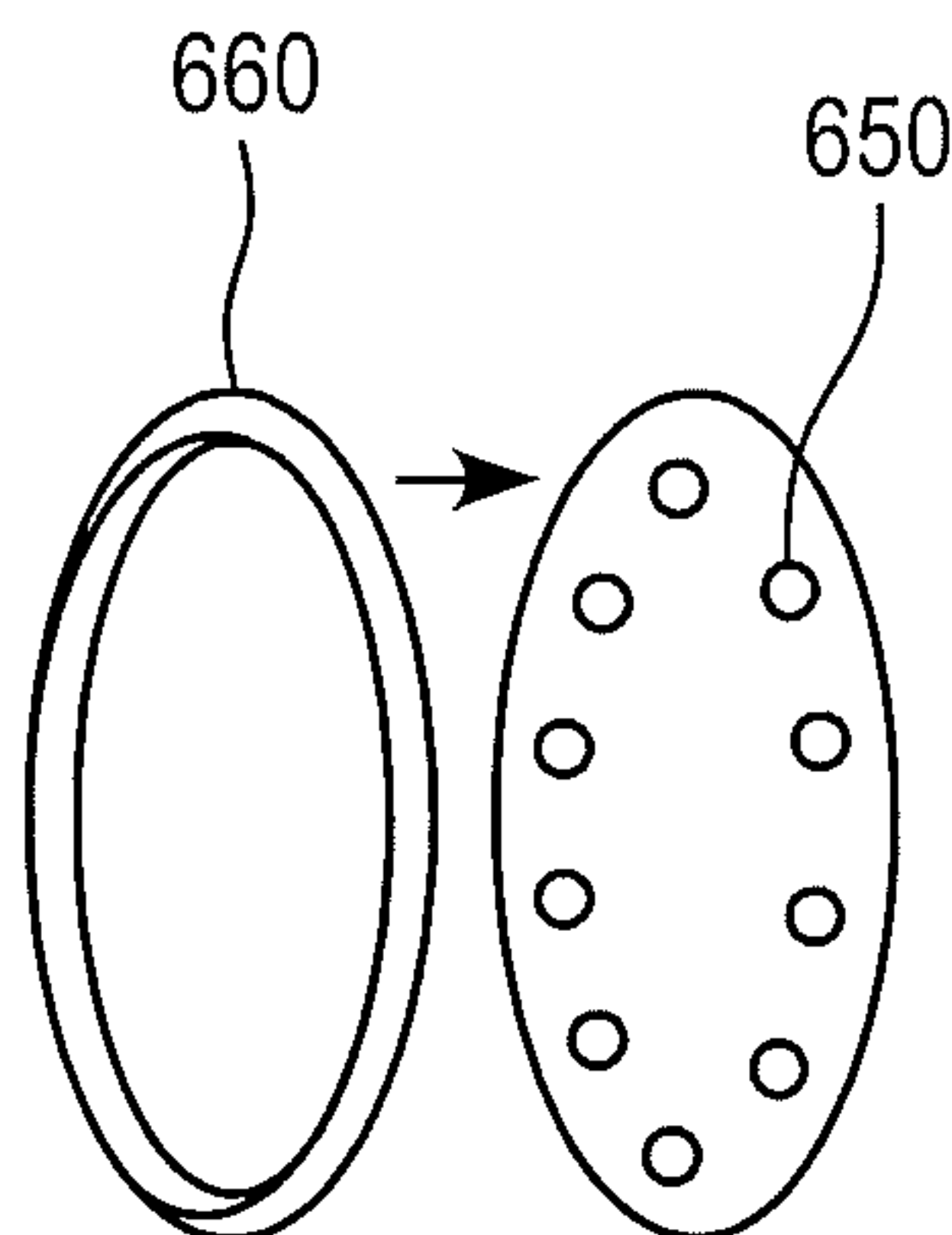

FIG. 6C

FIG. 7A

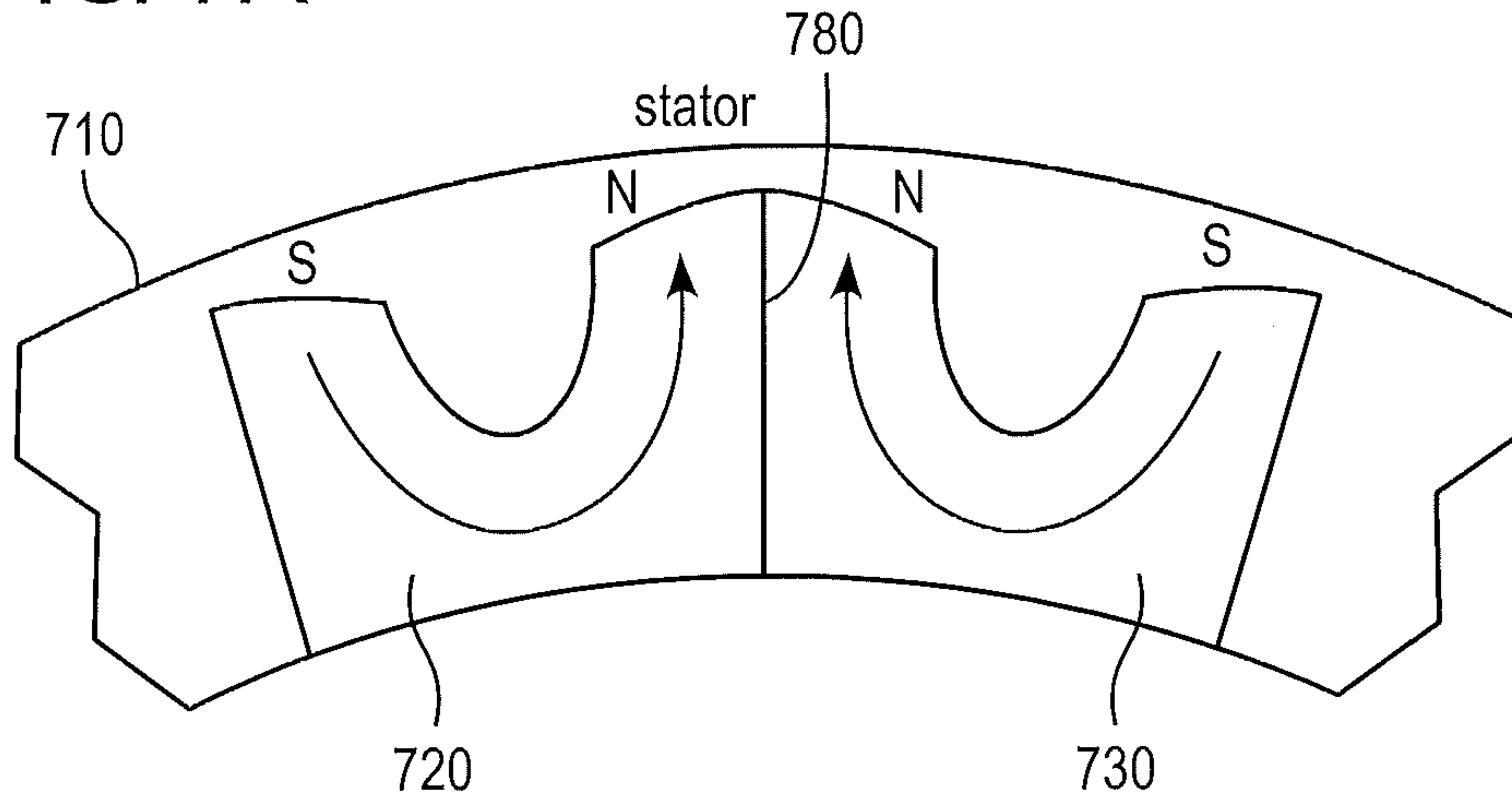

FIG. 7B

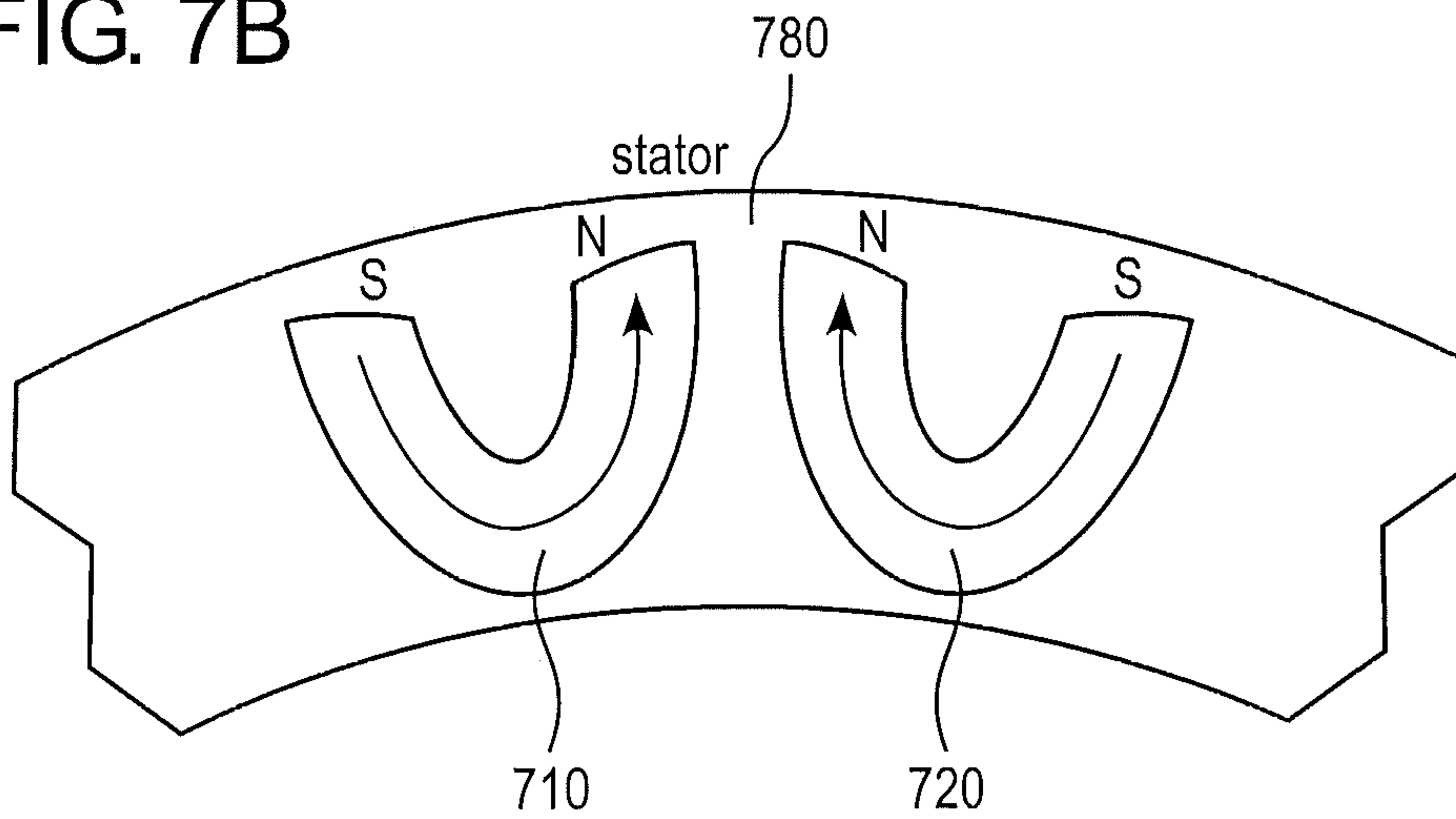

FIG. 8A

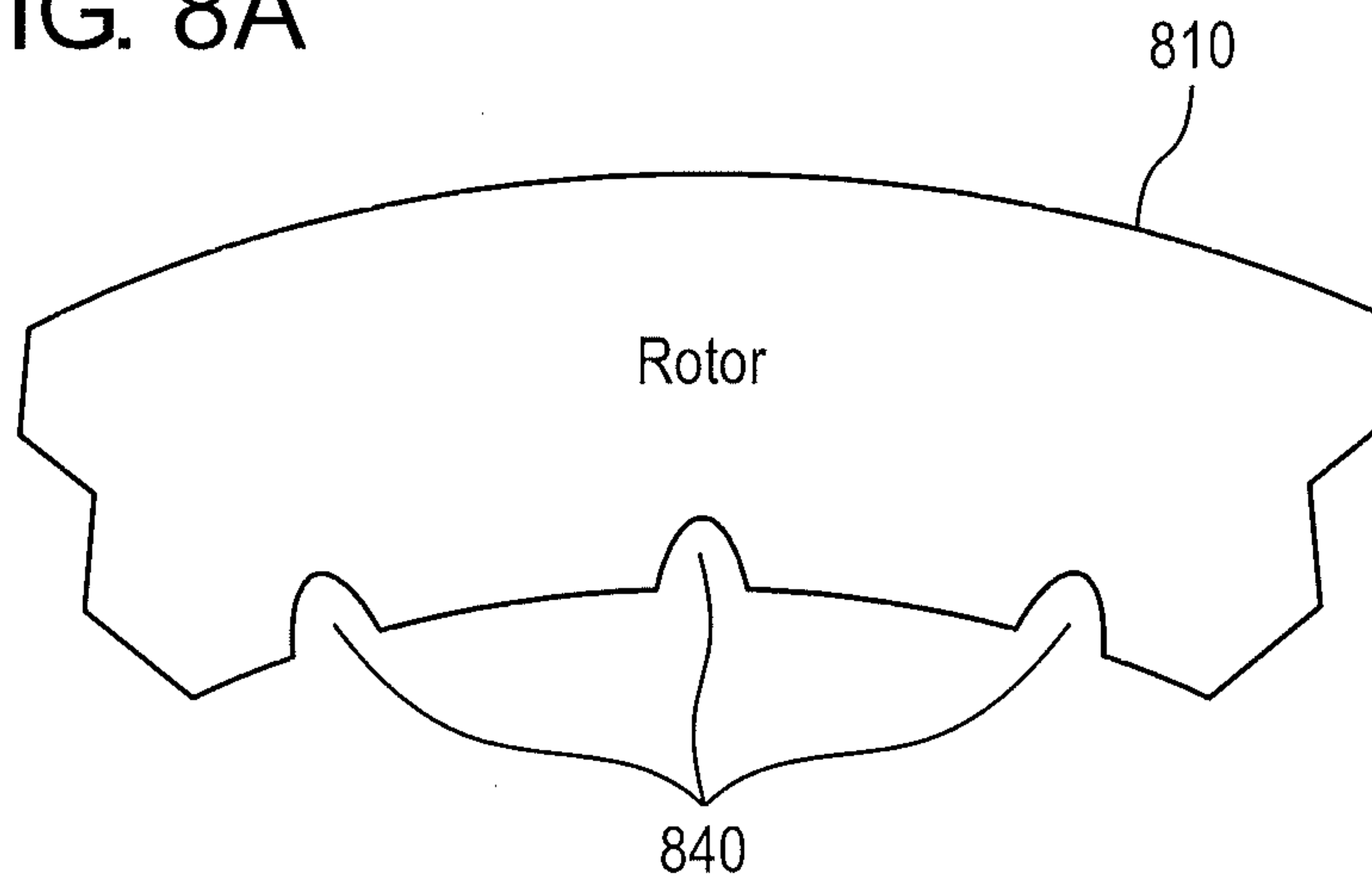
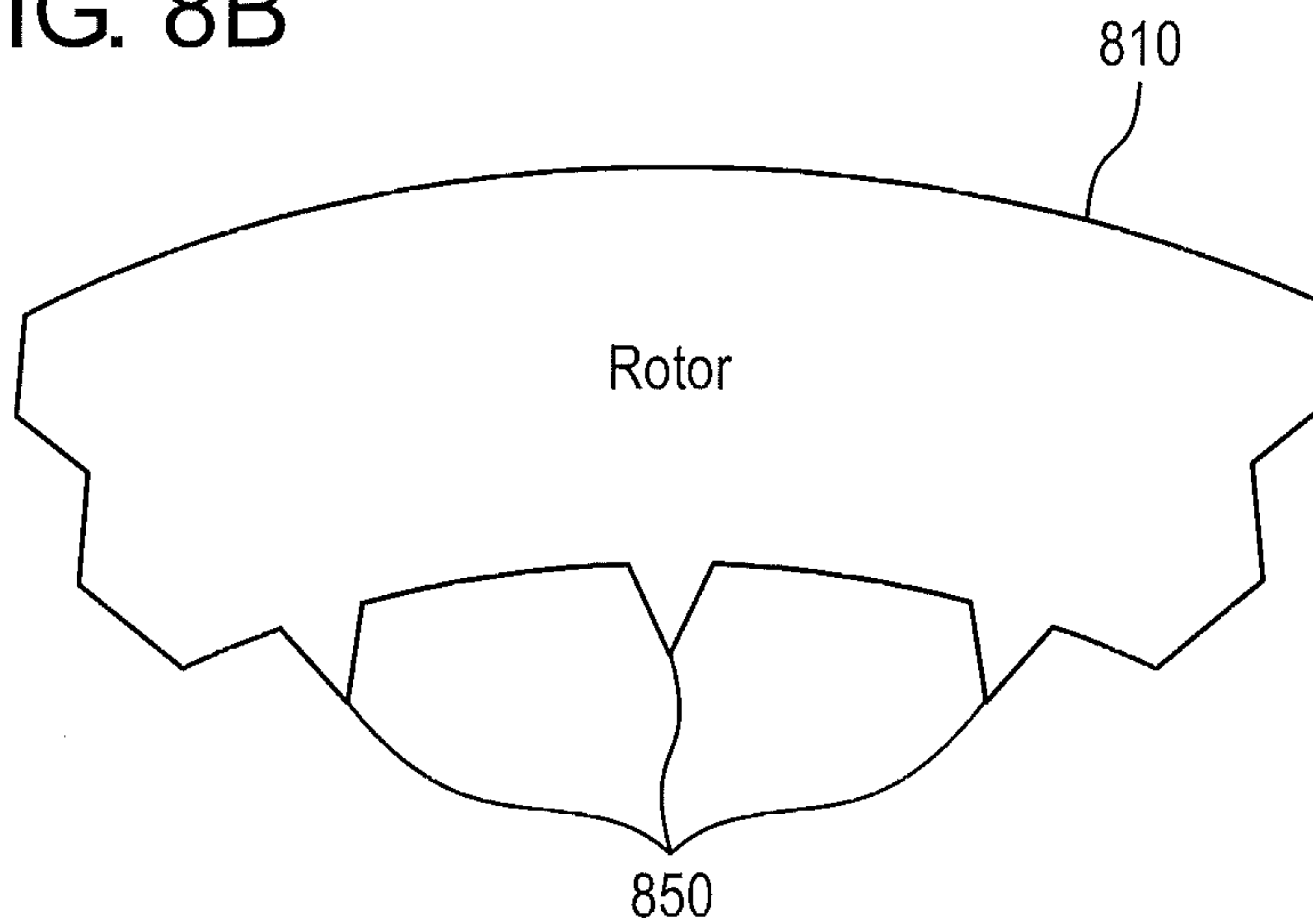

FIG. 8B



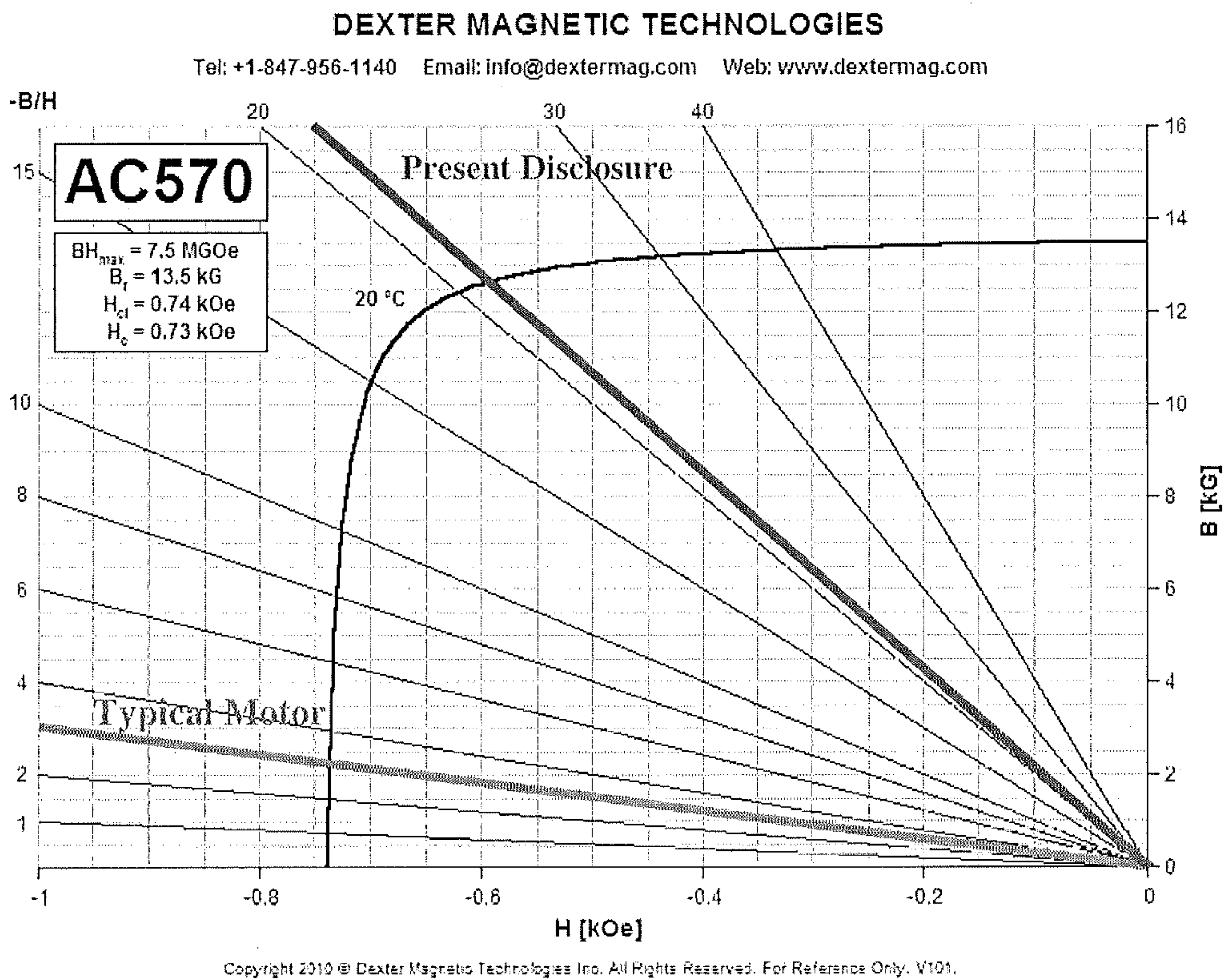

Figure 9

Figure 10

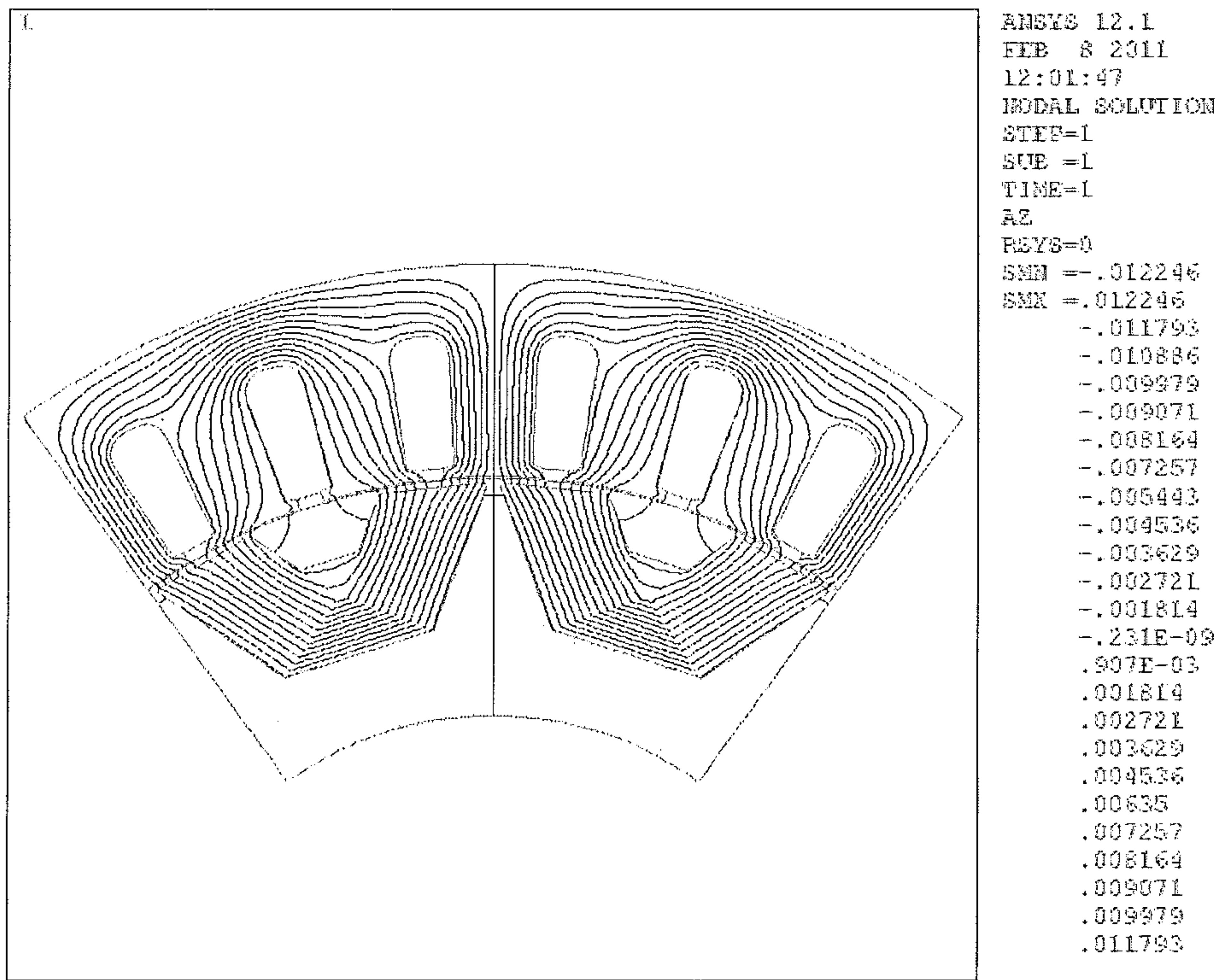

FIG. 1A

