

R. L. EBERMAN.
 FLUID ELEVATOR.
 APPLICATION FILED APR. 5, 1909.

954,270.

Patented Apr. 5, 1910.
 2 SHEETS—SHEET 1.

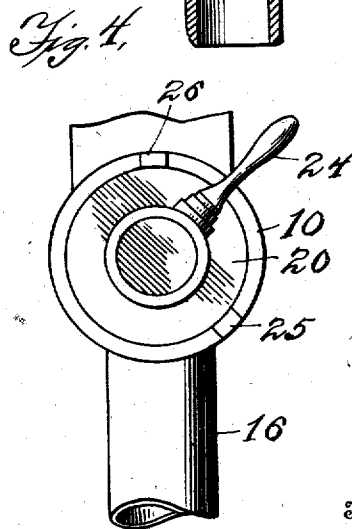
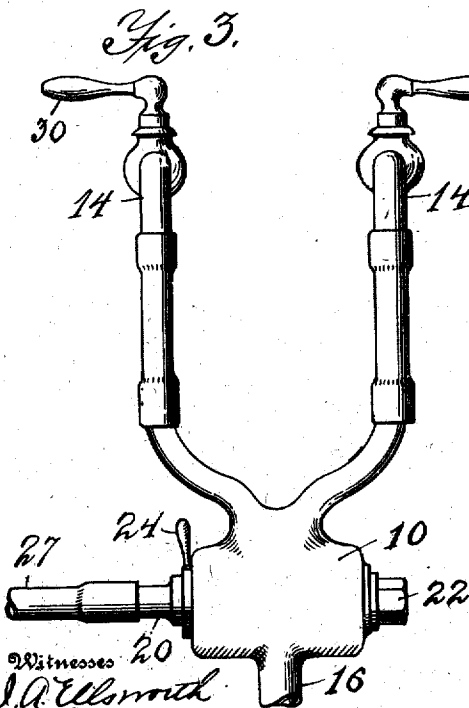
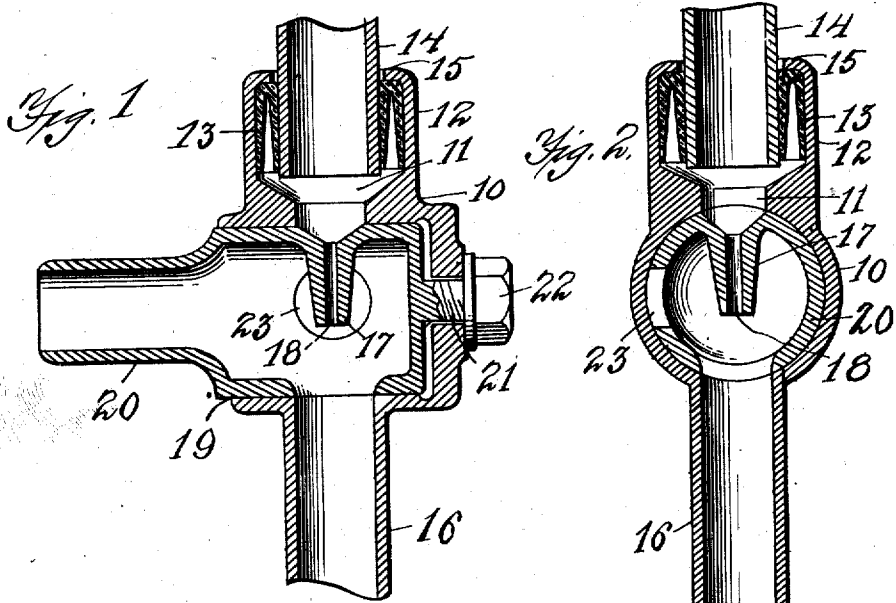

Witnesses
 J. A. Ellsworth
 Arthur Little

Inventor
 Ralph L. Eberman
 384 J. Arthur Baldwin,
 Attorney

R. L. EBERMAN.
 FLUID ELEVATOR.
 APPLICATION FILED APR. 5, 1908.

954,270.

Patented Apr. 5, 1910.
 2 SHEETS—SHEET 2.

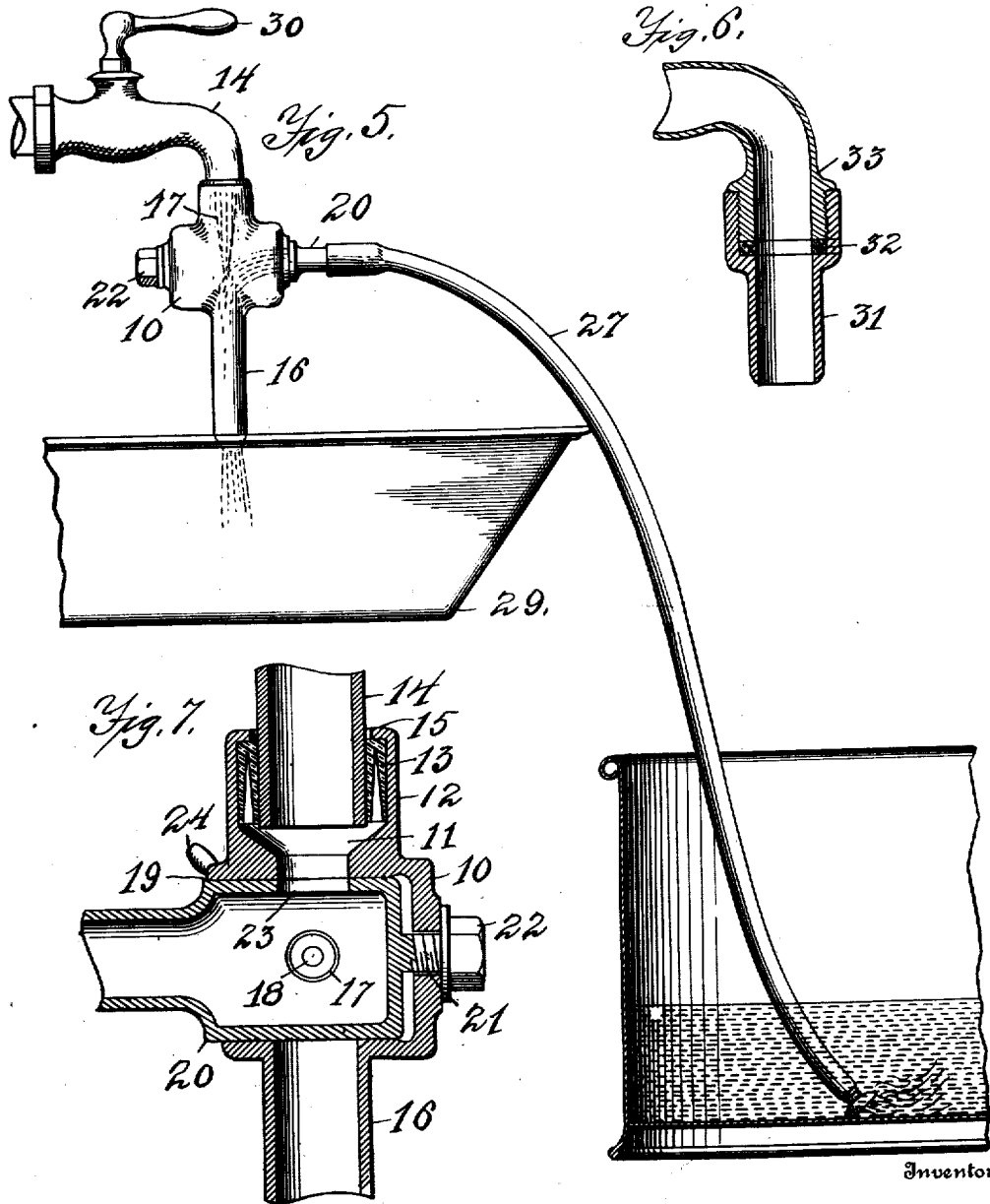

Witnesses
J. A. Ellsworth
Arthur

Inventor
Ralph L. Eberman
 384
J. Arthur Baldwin
 Attorney

UNITED STATES PATENT OFFICE.

RALPH L. EBERMAN, OF JAMESTOWN, NEW YORK.

FLUID-ELEVATOR.

954,270.

Specification of Letters Patent.

Patented Apr. 5, 1910.

Application filed April 5, 1909. Serial No. 488,026.

To all whom it may concern:

Be it known that I, RALPH L. EBERMAN, a citizen of the United States, residing at Jamestown, county of Chautauqua and State of New York, have invented new and useful Improvements in Fluid-Elevators, of which the following, taken in connection with the accompanying drawing, is a full, clear, and exact description.

10 The invention relates to attachments for controlling the flow of water and other fluids and more particularly in connection with faucet, whereby the fluids may be raised from one level to another, as for example, 15 in emptying tubs and other receptacles; and the object of my improvement is first, to provide a connection to the faucet which may be easily and quickly attached thereto, and when so attached the pressure of the fluid itself will aid in holding the attachment on the faucet; second, in providing means for a jet of fluid within the attachment which shall act as an ejector or elevator in raising the fluid through connective 20 tubing; and third, to arrange said injector or force producing portion of the fixture in valvular form so that the fixture may be used both for withdrawing the fluid from the receptacle and by turning said valvular portion for filling the receptacle, and the invention resides in the arrangement and combination of the parts, as shown in this specification and drawings and pointed out in the claims.

35 In the drawings, Figure 1 is a vertical lengthwise sectional view of the fluid elevator attached to the faucet the main portion of the faucet being broken away, as shown at line X X in Fig. 7; and Fig. 2 is a vertical crosswise sectional view of the fluid elevator at line Y Y in Fig. 1, each of the views showing the manner of attachment to the faucet and the manner of forcing the fluid in order to elevate the same. Fig. 3 40 is a front elevation of the fluid elevator showing the manner of attachment to two faucets to receive therethrough hot and cold fluids. Fig. 4 is a front elevation of the fluid elevator showing the manner of control for the revoluble central portion. Fig. 5 is

a side elevation of the faucet with the fluid elevator attached thereto, showing its tubular connection to the lower receptacle in order to elevate the fluid therefrom. Fig. 6 is a sectional view of the threaded end of a 55 faucet showing connection for receiving the fluid elevator thereon. Fig. 7 is a vertical lengthwise sectional view of the fluid elevator with the central portion turned so as to allow the fluid to pass through the same for 60 filling receptacles.

Similar numerals refer to corresponding parts in the several views.

The tubular fluid connection or elevator consists of angular tubular part or parts 65 which allows the fluid to flow in horizontally and be forced out vertically or nearly so.

In order to form an instantaneous and fluid tight connection for the elevator attachment to the end of the faucet the upper 70 part of the casing 10 of the elevator is formed with a chamber 11 within which a circular rubber packing 12 is provided which is bent back upon itself so as to form the opening 13 within the rubber packing. The opening within the rubber packing 12 for the faucet end 14 is of such a size as to spring upon and fit closely to the sides of the lower tubular end of the faucet. The chamber 11 is so formed that the fluid as 80 admitted under pressure through faucet 14, will enter chamber 11 and flow up into the space 13, thereby pressing the rubber packing 12 upon the outer side of the faucet and the inner side of the casing 10, and 85 forming a fluid tight connection, as well as a strong and instantaneous connection of the attachment 10 to the faucet, it only being necessary to press the lower end of the faucet into the opening within the rubber 90 packing 12. The upper part 15 of the casing 10 is extended nearly to the outer side of the faucet so that the packing 12 can not be pressed or forced out by the fluid pressure, but will be confined in place and pressed 95 against the sides of the faucet and casing.

Immediately below and in line with the mouth of the faucet 14, a tubular projection 16 is made on the casing 10, leading to the sink or other receptacle into which it is de- 100

sired to empty the water or other fluids. Above the tubular projection 16 and in line therewith between faucet 14 and part 16, a small nozzle 17 is provided having an opening 18 therethrough in order to force a jet of fluid down through the larger tube 16.

The casing 10 might be made in one part and attain my purpose, but is preferably made in two parts, as shown so that one part may turn within the other. Toward this end a tubular opening 19 is made within the part 10 and a second part 20 is revolvably mounted within opening 19, being securely attached therein by means of the projection 21 which extends out through the side of part 10 and nut 22, thereby holding the part 20 firmly in place and adjusting it to the desired position as well as drawing it to a fluid tight joint between the two parts very much after the manner which is common in the construction of valves of different kinds.

The nozzle 17 is preferably formed within part 20, extending toward the center of the same and in line with the opening 11 when the parts are assembled. A second opening 23 is provided in part 20 in line with opening 11, so that hole 23 may be turned into conjunction therewith, as shown in Fig. 7, when it is desired to fill a receptacle. Part 20 is turned by means of a handle 24 attached thereto and extending up between projecting lugs 25 and 26 on part 10. The outer end of part 20 is drawn into tubular shape suitable for the attachment of a hose 27, as shown in Fig. 5, which hose may extend to a receptacle 28 lower than the sink 29 into which it is desired to empty the fluid.

In order to start the siphonic elevation of the fluid the hose 27 should be filled with the fluid. It is obvious that this is very easily accomplished by turning handle 24 so as to bring opening 23 in conjunction with opening 11, thereby closing tube 16 and nozzle 17 and allowing the fluid to flow out through the hose 27, thereby filling said hose. Handle 24 can then be instantly turned back while the force from the faucet 14 is still turned on, thereby allowing the fluid under pressure to be forced through nozzle 17 creating a strong downward jet through tube 16 into sink 29, the force of the jet will cause the fluid to be drawn from the receptacle 28 and forced out through the tube 16 into the sink, thereby emptying the receptacle. It is obvious that when it is desired to fill the receptacle the handle 24 may be turned as above described, allowing the fluid to flow out through hose 27 into the receptacle.

In Fig. 8 is shown a double connection for attachment to two faucets to be used in

cases where it is desired to mix two different fluids for the admission of fluids of different temperatures, as for example, hot and cold fluids.

In order that instantaneous connection may be made to faucets 33 having a screw thread, a connecting tubular end 31 is provided having a threaded socket with rubber washer 32 therein, so that end 31 may be placed upon the faucet. It is apparent that the fluid elevator can be instantly pressed upon tubular end 31 or quickly removed therefrom, the saving of time in screwing on a hose or tube 27 being a large factor in promoting the work of a busy laundry or kitchen.

I claim as new:

1. In a device of the character described, a valve casing adapted for attaching to a faucet, a tubular part revolvably mounted in said valve casing at right angles thereto, said tubular part having a plurality of different sized openings therein.

2. In a device of the character described, a valve casing adapted for attaching to a faucet, a tubular part revolvably mounted in said valve casing at right angles thereto, said tubular part having a plurality of different sized openings in line with said faucet said openings in said tubular part arranged with a small opening opposite a large opening.

3. In a device of the character described, a valve casing adapted for attaching to a faucet, a tubular part revolvably mounted in said valve casing at right angles thereto, said tubular part having a plurality of openings in line with said faucet, a nozzle within said tubular part for one of said openings and opposite another of said openings, substantially as and for the purpose specified.

4. In a device of the character described, a valve casing adapted for attaching to a faucet, a tubular part revolvably mounted in said valve casing at right angles thereto, said tubular part having a plurality of openings in line with said faucet, a nozzle for one of said openings having its mouth opposite another of said openings to inject liquid therethrough.

5. In a device of the character described, a valve casing having means for attaching to a faucet, said casing having a round opening therein closed at one end, a tubular part closed at one end and revolvably mounted in said round opening, means for revolving said tubular part, said tubular part having a plurality of openings therein for ingress through said faucet and egress through said casing.

6. In a device of the character described, a valve casing adapted for attaching to a

faucet and having an exit opening there-
from, said casing having a round sidewise
opening therein closed at one end, a tubular
part revolubly mounted in said sidewise
5 opening and having a plurality of openings
therein in line with said faucet and said
exit opening from said casing, said tubular
part having a tubular nozzle extending in-
wardly opposite one of said openings, and

means for turning said tubular part, sub- 10
stantially as and for the purpose specified.

In testimony whereof I have hereunto
signed my name to this specification in the
presence of two subscribing witnesses.

RALPH L. EBERMAN.

Witnesses:

I. A. ELLSWORTH,
A. W. KETTLE.