

Dec. 5, 1944.

A. SAVITZKY

2,364,100

SLIDER FOR SLIDE FASTENERS AND METHOD FOR MAKING THE SAME

Filed Sept. 12, 1940

2 Sheets-Sheet 1

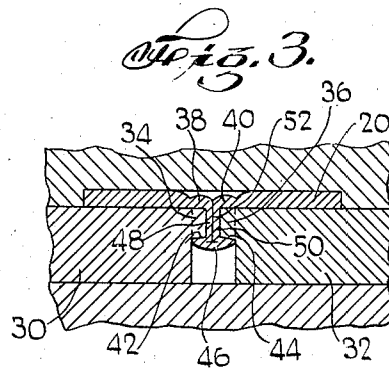
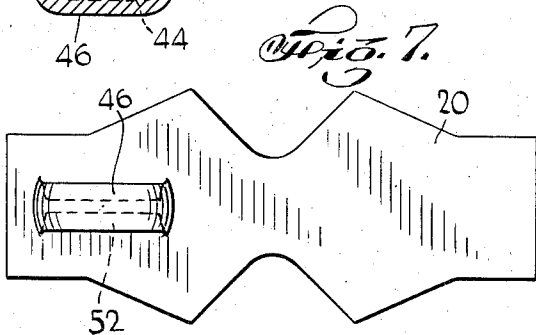
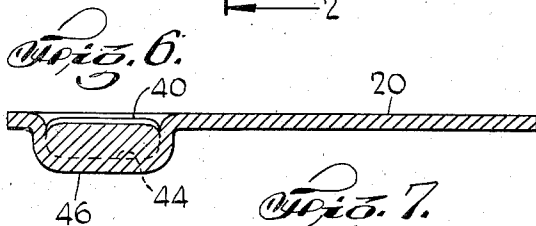
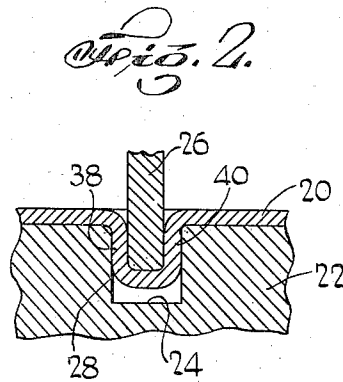
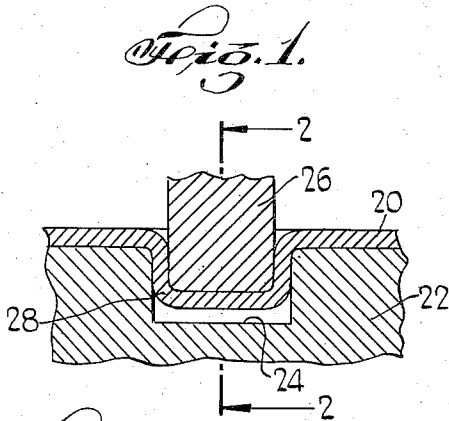
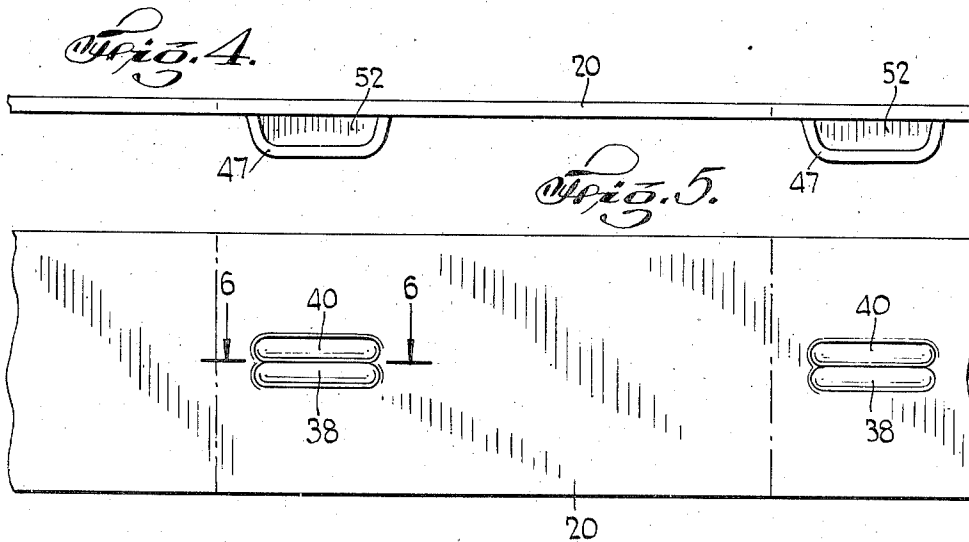

INVENTOR
ABRAHAM SAVITZKY
BY
Elyon S. Furshstein
ATTORNEY

Dec. 5, 1944.

A. SAVITZKY

2,364,100

SLIDER FOR SLIDE FASTENERS AND METHOD FOR MAKING THE SAME

Filed Sept. 12, 1940

2 Sheets-Sheet 2

Fig. 13.

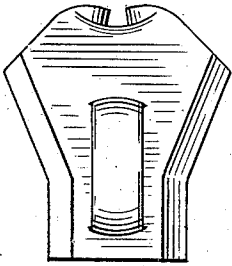

Fig. 14.

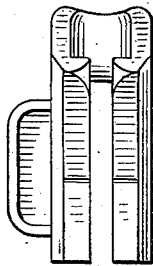

Fig. 15.

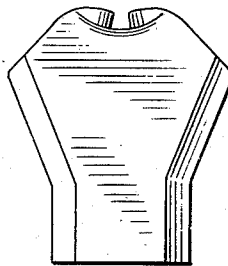

Fig. 8.

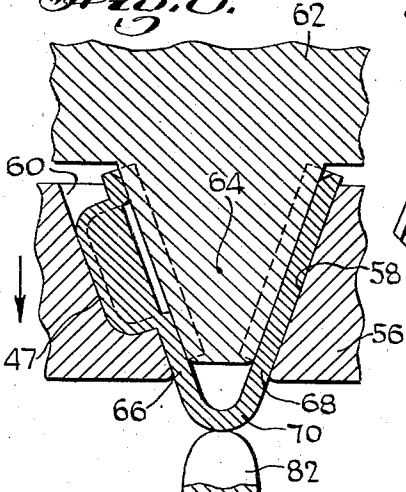

Fig. 12.

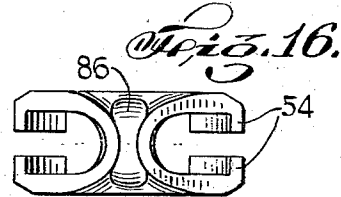
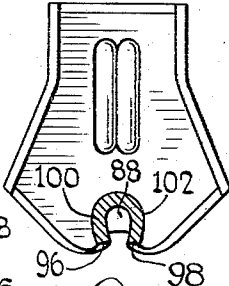

Fig. 9.

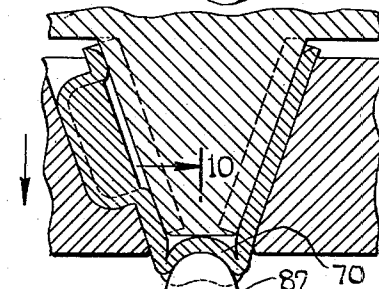

Fig. 11.

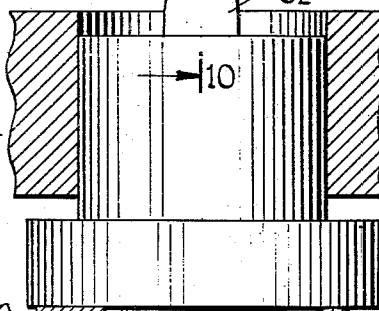
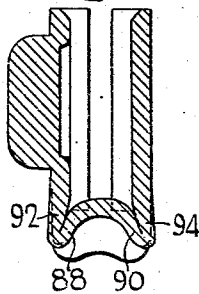
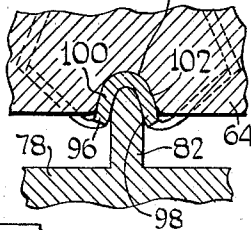

Fig. 10.



INVENTOR
ABRAHAM SAVITZKY
BY
Efoni Spuchstein
ATTORNEY

UNITED STATES PATENT OFFICE

2,364,100

SLIDER FOR SLIDE FASTENERS AND METHOD FOR MAKING THE SAME

Abraham Savitzky, Bronx, N. Y., assignor to
Marvel Slide Fastener Corporation, New York,
N. Y., a corporation of New York

Application September 12, 1940, Serial No. 356,417

27 Claims. (Cl. 29-148)

This invention relates to sliders for slide fasteners and to a method for making the same.

Principally, the invention is directed to the production of a slider which, although fabricated from sheet metal, is characterized by a high resistance to undesirable deformation during both manufacture and use.

One aspect of my invention resides in the novel form imparted to the slider neck. In sliders heretofore made it has been necessary to resort to many expedients to secure a rigid slider neck which would prevent the front and back plates of the slider from spreading or compressing during use. Thus in sheet metal sliders, rivets, yokes, welding and the like devices have been employed for securing the necessary strength of slider neck. But these devices render the slider bulky in appearance, and unduly increase the cost of manufacture. Sliders which have been manufactured by coining have employed special dies to create an extra thickness of metal at the neck, but this has entailed additional manufacturing expense, coined sliders being more expensive to manufacture than sheet metal sliders. It has also been proposed to shape the neck of sheet metal sliders by a plurality of forming operations into hollow sections which debouch on both the upper and lower slider wings. Such construction, however, requires an extremely complicated manufacturing procedure, presents an unsightly appearance in the slider and does not strengthen the joint between the slider wings and the slider neck.

An object of my invention, therefore, is to provide a slider made of sheet metal in which the neck is so shaped that the resistance to spreading or compression of the wings is greatly increased, and which shall withal be both economical to produce and pleasing in appearance.

Another object of my invention is concerned with the bail from which the slider finger piece depends. Heretofore this bail has been formed by a coining or upsetting operation, by employing additional parts which were riveted or welded to the slider body, or by striking upwards a portion of a wing to form an embryonic ball member. This latter method of providing a bail, although economical, considerably weakens the wing on which it is formed and results in a spreading of the slider flanges associated with the said wing, throwing them out of alignment with the corresponding slider flanges associated with the unmutilated wing. In accordance with my invention, the bail is formed by cupping the material of one of the wings and then collapsing

the cup. In this manner I produce a strong, imperforate wing with a bail integrally formed thereon, at a low cost of manufacture.

Other objects of this invention will in part be obvious and in part hereinafter pointed out.

The invention accordingly consists in the features of construction, combinations of elements, and arrangement of parts which will be exemplified in the construction hereinafter described, and of which the scope of application will be indicated in the claims.

In the accompanying drawings, in which is shown one of the various possible embodiments of this invention,

Fig. 1 is a sectional view through a pair of cooperating die members showing the cupping operation being performed on a slider strip during the formation of a bail;

Fig. 2 is a sectional view taken substantially along the plane represented by the line 2-2 in Fig. 1;

Fig. 3 is a sectional view through a pair of cooperating die members showing the process of collapsing certain portions of the side wall of the cup to complete the bail;

Fig. 4 is an elevational view of a strip having my novel bail members formed therein;

Fig. 5 is a top plan view thereof;

Fig. 6 is a sectional view taken substantially along the plane represented by the line 6-6 in Fig. 5;

Fig. 7 is a plan view of a slider blank after the bail member has been formed therein;

Fig. 8 is a sectional view through a pair of cooperating die members showing an early step during the process of forming my novel slider neck;

Fig. 9 is a similar view at a later stage of operation of said dies;

Fig. 10 is a sectional view taken substantially along the plane represented by the line 10-10 in Fig. 9;

Figs. 11 and 12 are mid-sectional views in elevation and plan of a slider ejected from the dies shown in Fig. 9 after the wings thereof have been brought into parallel superposed relationship; and

Figs. 13, 14, 15 and 16 are front, side, rear and top views respectively of a finished slider embodying my invention.

Referring now to the drawings, and more particularly to Figs. 1 through 7, I have shown the bail-forming steps in the production of my novel slider.

A strip 20 of sheet metal is first passed through

a pair of cooperating die members comprising a die block 22 having a cavity 24 suitably formed therein which cooperates with a plunger 26 to form a raised cup 28 on the lower surface of the strip 20. I prefer to form said cup 28 in two pressing operations, during the first of which the cup is drawn slightly larger than the ultimate size required, and in the second of which the cup is brought down to the desired dimensions shown in Figs. 1 and 2. However, said cup may be formed in any number of steps desired.

After the cupping operation, the strip is advanced to a pair of cooperating die members 30 and 32 having a pair of aligned fingers 34 and 36 which are adapted to press into the opposite side walls 38 and 40 (see Fig. 2) of the cup 28 to collapse the same inwardly into the shape shown in Fig. 3. It will be seen from Fig. 3 that the upper portions 38 and 40 of the said walls of the cup are shifted into the plane of the strip 20 so as to form a continuous web; that the lower portions 42 and 44 of the side walls are forced into abutment with the bottom of the cup to provide a reinforcement for the upper ridge 46 on the ball member 47; and that the central portions 48 and 50 of the side walls are firmly pressed against each other to form a central web 52 dividing the two sides of the ball member. It should also be noted that the adjacent lower, central and upper portions of the cup so tightly abut against one another, that to all intents and purposes they act as a unitary piece of metal, and in actual practice the seam indicated in Fig. 3 is not even discernible to the naked eye.

After the operation indicated in Fig. 3, the upper side of the web (opposite from that on which the ball is formed) will assume the configuration indicated in Figs. 3, 5 and 6, comprising to outward appearance a pair of juxtaposed elongated rectangular surfaces having raised central portions.

Subsequent to the formation of the ball members, the strip is stamped by any conventional means to form slider blanks such as shown in Fig. 7. The slider blanks may then be processed either individually or in the strip, in any manner well known to the art, to provide the usual flanges 54 and to shape the slider blanks into a V form (shown in Fig. 8). It should be noted that as both the slider wings are of substantially the same imperforate cross section, they will offer the same resistance to bending, so that the flanges 54 on both wings will be similarly disposed.

After the slider has been fashioned to the V-shape, it is processed in the series of operations indicated in Figs. 8-12 to form a slider neck in accordance with my invention. First the slider is inserted into a die block 56 having a trough 58 provided therein which has a slot 60 on one of its inclined surfaces to slidably receive the ball member 47 and position the slider. The trough opens into the lower surface of the die block 56 to allow the bottom bent portion 70 of the V-shaped slider to protrude. A cooperating die block 62, which is mounted for reciprocation into the block 56, has a finger portion 64 which is adapted to enter between the inner walls of the wings 66 and 68 of the slider and to tightly press the same against the block 56 and lock the slider between the die blocks 56 and 62. Below the block 56 I provide a table 72 having a stationary post 74 suitably supported thereon. The post 74 is slidably received in the bore 76 of a lower die block 78. A heavy spring 80 encircles the post 74 and abuts against the lower surface of the die block 78 to

normally maintain the same in its uppermost position. Projecting from the upper surface of the die block 78 is a plunger 82 having a rounded convex forming surface (see Figs. 8, 9 and 10). The top of the said plunger 82 is adapted to be positioned slightly below the lower portion 70 of the V-shaped slider when said slider is initially locked between the die blocks 56 and 62, as indicated in Fig. 8. The die blocks 56 and 62 are then simultaneously moved downward towards the die block 78, the neck portion 70 of the slider being pressed against the resiliently mounted plunger 82 and thus forcing the portion 70 inwardly between the walls of the wings 66 and 68 until the portion 70 assumes the inverted shape shown in Figs. 10 and 11, and abuts against the female die cavity 86 provided for this purpose at the tip of the finger 64. By resiliently mounting the plunger 82 I prevent the portion 70 from being struck free from the rest of the slider. By forcing the portion 70 backwards into the slider a deep well 86 is formed in the slider neck perpendicular to the slider wings, the upper portions 88 and 90 of the side walls of said well being firmly pressed against the adjacent ends 92 and 94 of the slider wings. These adjacent portions are so tightly pressed together that the seam between them is not discernible to the naked eye, and like the ball web portions 48 and 50 they act to all intents and purposes as a single integral piece of metal.

By thus providing a heavy piece of metal at the juncture between the neck and the slider wings I appreciably reinforce the same against bending at this point. However, the dimension of the plunger 82 corresponding to the height of the slider is less than the distance between the slider wings so that most of the well 86 is hidden from sight when viewed from the front or back wing of the slider, and thus provides a highly attractive appearance to the slider.

At this stage in the formation of the slider neck the upper edges 96 and 98 (see Fig. 10) of the groove 86 are spaced apart a relatively large distance to provide diverging walls in said groove. After initially forming the groove 86 the wings of the slider are bent into parallel superposed relation, as shown in Figs. 11 and 12. This causes the upper edges 96 and 98 to approach each other, as shown in Fig. 12, and impart a nearly closed shape to the neck section.

The slider may finally be shaped to bring it to dimensions and to remove the slightly protruding edges adjacent the upper end of the groove, which are shown in Fig. 11, and thus provide the finished appearance indicated in Figs. 13 through 16. From Figs. 13-16 it will be seen that the transverse walls 100 and 102 of the groove 86 provide extremely deep webs which maintain the slider plates 66 and 68 in spaced relationship; but that these webs are for the most part concealed beneath the slider wings and thus avoid the unsightly appearance which would be caused by a deep V indented in the neck of the slider.

I have found that a slider constructed in accordance with my invention offers about 50% more resistance to spreading or compressing of the slider plates and does not tend to jam either originally or during continued use due to misalignment of the slider flanges.

It will thus be seen that there is provided a device and method for making the same in which the several objects of this invention are achieved, and which is well adapted to meet the conditions of practical use.

As various possible embodiments might be made of the above invention, and as various changes might be made in the embodiments above set forth, it is to be understood that all matter herein set forth or shown in the accompanying drawings is to be interpreted as illustrative and not in a limiting sense.

Having thus described my invention, I claim as new and desire to secure by Letters Patent:

1. In a method of manufacturing a sheet metal slider for a slide fastener, the steps comprising disposing a pair of slider wings interconnected by an integral neck portion in angular relationship with respect to each other, indenting the neck portion and then bending said wings into parallel superposed relationship.

2. In a method of manufacturing a sheet metal slider for a slide fastener from a blank including a pair of wings interconnected by an integral neck, the steps comprising disposing said wings in relatively angular relationship, creasing said neck transversely of the planes of said wings and from one to the other of said angularly disposed wings to such an extent that the bottom of the formed crease near the front and back of said slider is below the adjacent edges of said wings, and then bending said wings into parallel superposed relationship.

3. In a method of manufacturing a sheet metal slider for a slide fastener, the steps comprising disposing a pair of slider wings interconnected by an integral neck portion in angular relationship with respect to each other, indenting a deep well in said neck portion, and bending said wings into parallel superposed relationship.

4. In a method of manufacturing a sheet metal slider for a slide fastener comprising a pair of parallel wings interconnected by an integral neck, that step comprising creasing said neck transversely of the planes of said wings and from one to the other of said wings to such an extent that the bottom of the formed crease near the front and back of said slider is below the adjacent edges of said wings.

5. In a method of manufacturing a sheet metal slider for a slide fastener wherein said slider comprises a pair of slider wings interconnected by an integral neck portion, the steps comprising forming a cup on one of said wings, pressing oppositely disposed portions of said cup into abutment with each other, pressing portions of said cup into the plane of said wing, indenting a deep well in said neck, and compressing wall portions of said well against said wings.

6. In a method of manufacturing a sheet metal slider for a slide fastener, the steps comprising forming a cup on one of the wings and collapsing oppositely disposed portions of said cup into juxtaposition beneath an intermediate portion of the said cup between the portions collapsed while leaving said intermediate portion uncollapsed to provide a rim around the juxtaposed collapsed portions extending to both sides thereof.

7. In a method of manufacturing a sheet metal slider for a slide fastener, the steps comprising forming a cup on one of the wings and pressing oppositely disposed portions of said cup into abutment with each other to provide a web beneath an intermediate portion of said cup between the portions pressed into abutment while leaving said intermediate portion uncollapsed to provide a rim around said web extending to both sides of the plane thereof.

8. In a method of manufacturing a sheet metal slider for a slide fastener, the steps comprising

forming a cup on one of the wings, pressing oppositely disposed portions of said cup into abutment with each other, and pressing portions of said cup into the plane of said wing.

9. A sheet metal slider for a slide fastener comprising a pair of parallel sheet metal wings interconnected by an integral sheet metal neck which has an elongated inwardly extending indentation therein whose longitudinal axis is transverse to the planes of said wings.

10. A sheet metal slider for a slide fastener comprising a pair of parallel sheet metal wings interconnected by an integral sheet metal neck which has an elongated inwardly extending indentation therein whose longitudinal axis is transverse to the planes of said wings, the bottom of said indentation being below the adjacent top edges of said wings.

11. A sheet metal slider for a slide fastener comprising a pair of parallel sheet metal wings interconnected by an integral sheet metal neck which has an elongated inwardly extending indentation therein whose longitudinal axis is transverse to the planes of said wings, said neck having an inwardly bowed arcuate cross-section in a plane parallel to the direction of travel of the slider and including the longitudinal axis of said indentation.

12. A sheet metal slider for a slide fastener comprising a pair of parallel sheet metal wings interconnected by an integral sheet metal neck which has an elongated inwardly extending indentation therein whose longitudinal axis is transverse to the planes of said wings, said neck having an inwardly bowed arcuate cross-section in a plane parallel to the direction of travel of the slider and including the longitudinal axis of said indentation, and an inwardly bowed arcuate cross-section in a plane perpendicular to said first named plane and likewise parallel to the direction of travel of the slider.

13. A sheet metal slider for a slide fastener comprising a pair of parallel wings interconnected by an integral neck, said neck having an indentation therein between said wings, the ends of the bottom of said indentation lying adjacent said wings, the bottom of said indentation intermediate the ends thereof being no higher than said ends.

14. A sheet metal slider for a slide fastener comprising a pair of parallel wings interconnected by an integral neck, said neck having an indentation therein between said wings, the ends of said indentation lying adjacent said wings, said ends being higher than the portion of the bottom between them.

15. A sheet metal slider for a slide fastener comprising a pair of wings having spaced parallel plane portions interconnected by an integral neck, said neck having an indentation therein two walls whereof extend transversely between said wings and converge toward the bottom of said slider, the top edges of said plane portions adjacent the part of the neck where said walls converge being at least as high as the external surface of said part.

16. A sheet metal slider for a slide fastener comprising a pair of wings interconnected by an integral neck, said neck having a well comprising a bottom, two sides parallel to said wings and two sides perpendicular to said wings, said bottom and the two sides parallel to the wings being disposed wholly between said wings, the two sides perpendicular to said wings having a substantial portion thereof disposed between said wings.

17. A sheet metal slider for a slide fastener comprising a pair of wings interconnected by an integral neck, said neck having a well comprising a bottom, two sides parallel to said wings and two sides perpendicular to said wings, said bottom and the two sides parallel to the wings being disposed wholly between said wings, the two sides perpendicular to said wings having a substantial portion thereof disposed between said wings, the neck of said well being constricted.

18. A sheet metal slider for a slide fastener comprising a pair of wings interconnected by an integral neck, said neck having a well comprising a bottom, two sides parallel to said wings and two sides perpendicular to said wings, said bottom and the two sides parallel to the wings being disposed wholly between said wings, the two sides perpendicular to said wings having a substantial portion thereof disposed between said wings, the two sides which are parallel to said wings having the upper portions thereof compressed against said wings.

19. A sheet metal slider for a slide fastener comprising a pair of wings interconnected by an integral neck, said neck having a well formed therein of elongate, closed, cross-section along a plane adjacent the bottom of said well, which plane is perpendicular to said wings and extends from side to side thereof, the major dimension of said cross-section being disposed transversely of said wings.

20. A sheet metal slider for a slide fastener comprising a pair of imperforate wings interconnected by an integral neck portion, said neck having a deep well formed therein, said well including a bottom and four sides and being substantially fully concealed between said wings, portions of said well lying adjacent said wings being compressed against said wings, one of said wings having a bail integral therewith.

21. A sheet metal slider for a slide fastener having a pair of parallel sheet metal wings interconnected by a neck, a bail on one of said wings integrally formed from the material of the wing in the vicinity of the bail, said bail terminating short of the edges of said wing and comprising a web which is directly connected to and extends integrally away from said wing and a rim on the extended edge of said web which projects to both sides thereof, said rim being integrally connected to said wing at the ends of said bail.

22. A sheet metal slider for a slide fastener having a pair of parallel sheet metal wings interconnected by a neck, a bail on one of said wings integrally formed from the material of the wing in the vicinity of the bail, said bail terminating short of the edges of said wing and comprising a web which extends integrally away from said wing and a rim on the extended edge of said web which projects to both sides thereof,

said web including two plane sheet metal portions each integrally connected along an edge thereof to said wing and extending away therefrom and said rim including a sheet metal strip having inturned edges each of which is integrally connected to the extended edge of one of the plane web portions, the sheet metal strip and inturned edges thereof being integrally connected to said wing at the ends of said bail.

23. A sheet metal slider for a slide fastener having a pair of parallel sheet metal wings interconnected by a neck, an integral bail on one of said wings which terminates short of the edges of said wing, the central web of said bail comprising a pair of juxtaposed bent portions which together form a wall of double thickness, said bent portions being integral with said wing and being integrally connected to each other at the ends of said bail.

24. A sheet metal slider for a slide fastener having a pair of parallel sheet metal wings interconnected by a neck, one of said wings being imperforate and having an integral bail thereon which terminates short of the edges of said wing, the central web of said bail comprising a pair of abutted parallel walls integral with said wing and integrally connected to each other at the ends of said bail.

25. A sheet metal slider for a slide fastener having a pair of parallel sheet metal wings interconnected by a neck, one of said wings being imperforate and having an integral bail thereon which terminates short of the edges of said wing and extends therefrom, said bail having a central web comprising a pair of abutted parallel walls integral with said wing and integrally connected to each other along their extending edges.

26. A sheet metal slider for a slide fastener having a pair of parallel sheet metal wings interconnected by a neck, one of said wings being imperforate and having an integral bail thereon, said bail including a web comprising a pair of parallel abutted portions integral with and perpendicular to said wing and a wall disposed about the outer periphery of said web, said wall having inturned longitudinal edge portions abutting said wall and integral with said web portions.

27. A sheet metal slider for a slide fastener having a pair of parallel sheet metal wings interconnected by a neck, one of said wings being imperforate and having an integral bail thereon, said bail comprising a thinned portion having a segment disposed in the plane of said wing, a pair of parallel abutting segments forming the web of said bail, and a segment disposed about the periphery of said web part, said last segment having inturned longitudinal edges integral with said web segments.

ABRAHAM SAVITZKY.