

Oct. 31, 1950

J. J. BURGUN  
ELECTRIC HEATER

2,528,030

Filed Aug. 10, 1949

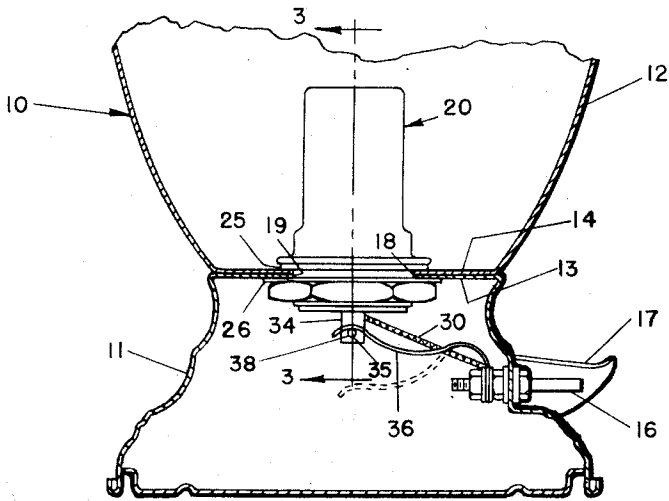

FIG-1

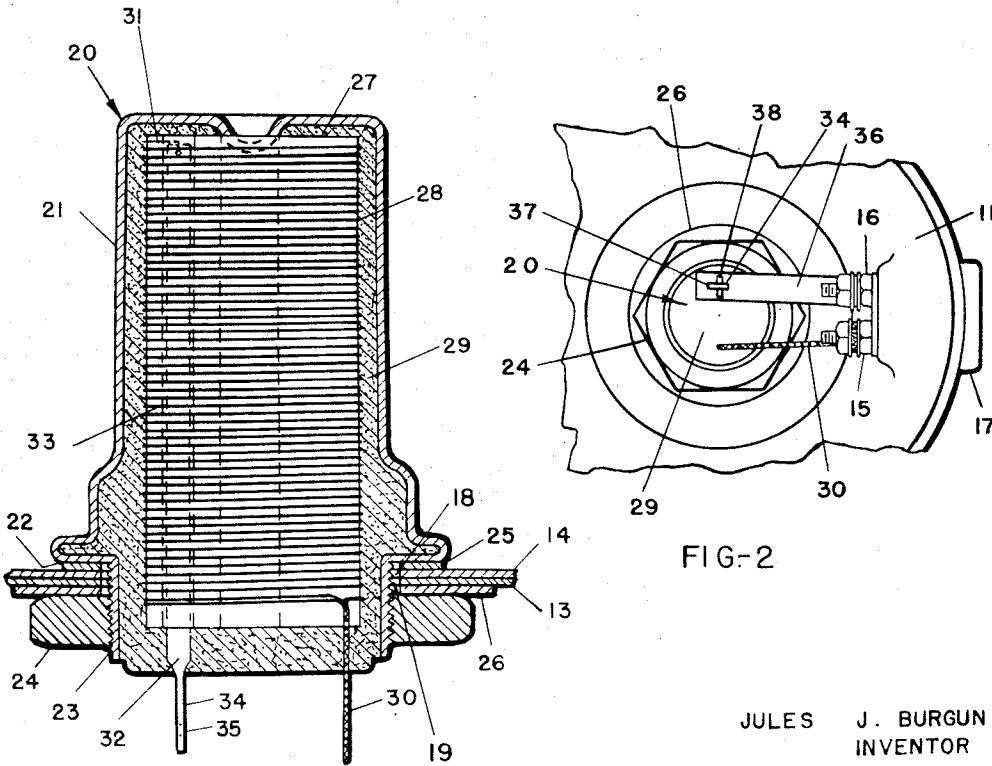
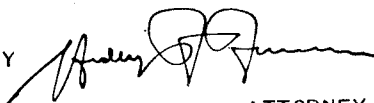

FIG-2

FIG-3

JULES J. BURGUN  
INVENTOR

BY   
ATTORNEY

# UNITED STATES PATENT OFFICE

2,528,030

## ELECTRIC HEATER

Jules J. Burgun, Wilkensburg, Pa., assignor to  
Edwin L. Wiegand Company, Pittsburgh, Pa., a  
corporation of Pennsylvania

Application August 10, 1949, Serial No. 109,605

10 Claims. (Cl. 219-19)

1

My invention relates to electric heaters, and particularly to electric heaters incorporating means for protecting the heater against over-temperature, and the principal object of my invention is to provide an improved heater of this type.

In the drawing accompanying this specification and forming a part of this application I have shown for purposes of illustration what I now consider to be the best mode of carrying my invention into practice particularly in respect of so-called immersion heaters employed for example in electric percolators, and in this drawing:

Figure 1 is a vertical section through a percolator including a heater according to my invention;

Figure 2 is a bottom view of the device of Figure 1; and

Figure 3 is an enlarged section through the heater, on the line 3-3 of Figure 1.

For purposes of illustration I have indicated in the drawings a percolator 10 comprising a base 11 and a container 12, both formed of sheet-metal, the base having a flat top 13 and the container a flat bottom 14 resting on the top 13 of the base 11, the base 11 being provided with electrically-insulated connection terminals 15 and 16 and with a terminal shield 17, and the container bottom 14 and base top 13 being provided with registering apertures 18 and 19 in which is mounted the illustrated electric heater 20.

As herein shown the heater 20 comprises a sheet-metal sheath 21 formed to provide a shoulder 22 beyond which projects a screw threaded cylindrical portion 23 receiving a nut 24 serving to maintain the heater in position, a gasket 25 preferably being interposed between the shoulder 22 and container bottom 14 and a washer 26 between the base top 13 and nut 24, to assist in maintaining a tight connection and avoiding any leakage through the container and base openings 18 and 19.

In the present embodiment, within the sheath 21 is a hollow cylindrical electrical-insulating and heat-conducting ceramic core 27 on which is wound a resistor 28, and embedding the core 27 and resistor 28 is a body of heat-conducting electrical-resisting material 29 serving to electrically insulate the resistor 28 and to conduct the heat from the resistor 28 to the sheath 21 and thus to the liquid within the container 12.

According to the present species of my invention, the lower end 30 of the resistor 28 is

2

suitably caught to the core 27 and then extends through the insulating material 28 and directly to the one connection terminal 15, and the upper end 31 of the resistor 28 is similarly caught to the core 27 and then connected to the inner end of a relatively heavy rod terminal 32 composed of copper or other electrically conductive material of high heat conductivity, located in a passage 33 in the core 27, and provided at its outer end, exteriorly of the insulating material 28, with a flattened extension 34 including an aperture 35.

With the foregoing, mounted on the other connection terminal 16 is a spring conductor 36 which is provided adjacent its free end with an aperture 37 whereby it may be positioned over and in electrical contact with the extension 34 of the terminal 32, thereby completing the circuit through the resistor 28 between the connection terminals 15 and 16, but is biased to the open-circuit position indicated by dotted lines in Figure 1, and is held in circuit-closed position only by a fusible member 38 positioned in the aperture 35 of the extension 34 of the terminal 32.

By reason of the described construction, inasmuch as the terminal 32 extends substantially within the heater 20 and is of high thermal conductivity, it will be subject to the temperature within the heater and will transmit that temperature to the extension 34 and thereby to the fusible member 38, and accordingly, upon over-temperature of the heater 20, as by reason of insufficient liquid within the container 12, the fusible member 38 will be fused, the spring conductor 36 will be released, and the circuit through the heater will be opened, and sufficiently quickly normally to avoid any damage to the heater or other portion of the appliance.

However, when the temperature has subsided, the apparatus may readily be restored to operating condition, merely by returning the spring conductor 36 to its position on the extension 34 and inserting a new fusible member 38.

Accordingly the present embodiment fully accomplishes at least the principal object of my invention, and on the other hand, obviously various changes and modifications may be made, within the scope of my invention, and therefore it will and is to be understood that my invention is not limited to the described embodiment, and I claim as my invention:

1. An electric heater comprising a resistor, a terminal for said resistor extending within said



5

be directly subject to internal temperature of said heater, having a portion accessible for electrical connection, and constructed to transmit heat to said portion, so that the temperature of said portion is responsive to internal temperature of said heater, fusible means located exteriorly of said heater in position to be heated by said portion according to the temperature of said portion and thus according to internal temperature of said heater, and spring means normally held by said fusible means in position closing the circuit to said terminal and biased to move to circuit open position upon fusion of said fusible means resulting from over-temperature of said heater.

10. An electric heater comprising a resistor, a terminal for said resistor extending within said heater at least sufficiently to be directly subject to internal temperature of said heater, having a portion accessible for electrical connection, and constructed to transmit heat to said portion, so that the temperature of said portion is responsive to internal temperature of said heater, said portion being adapted to transmit heat to

6

5 fusible means located exteriorly of said heater in position to be heated by said portion according to the temperature of said portion and thus according to internal temperature of said heater, and spring means constructed to be held by said fusible means in position closing the circuit to said terminal and biased to move to circuit open position upon fusion of said fusible means resulting from over-temperature of said heater.

JULES J. BURGUN.

## REFERENCES CITED

The following references are of record in the file of this patent:

## UNITED STATES PATENTS

Number	Name	Date
1,029,230	Russell	June 11, 1912
1,060,266	Lamb	Apr. 29, 1913
1,382,101	Lofts	June 21, 1921
2,034,486	Rohne	Mar. 17, 1936
2,266,480	Steiner	Dec. 16, 1941
2,306,913	Smith	Dec. 29, 1942