



US 20060102629A1

(19) **United States**

(12) **Patent Application Publication**  
**Ronnberg**

(10) **Pub. No.: US 2006/0102629 A1**

(43) **Pub. Date: May 18, 2006**

(54) **METHOD FOR PROTECTING BEVERAGE CAN FROM INSECTS**

**Publication Classification**

(51) **Int. Cl.**  
*B65D 17/34* (2006.01)  
*B65D 1/40* (2006.01)  
*A47G 19/22* (2006.01)  
(52) **U.S. Cl.** ..... **220/269; 220/719; 220/730**

(76) Inventor: **Magnus Ronnberg, Bromma (SE)**

Correspondence Address:  
**EASTH LAW OFFICES (ROLF FASTH)**  
**26 PINECREST PLAZA, SUITE 2**  
**SOUTHERN PINES, NC 28387-4301 (US)**

(57) **ABSTRACT**

The method is for preventing insects from entering an opening of a beverage can. The method provides for a beverage can that has a lever member with a handle member and an engaging member attached to a top surface of the beverage can. A cover member is placed on top of the top surface so that a protection area is placed above a weakened segment of the top surface and an inner opening segment is placed below the engaging member. The protection area has a plurality of elongate apertures defined therein. With the protecting area and the apertures placed on top of the weakened segment, the handle member is lifted to move the engaging member through the inner opening segment to push a portion of the weakened segment into the beverage can and creating an opening disposed below the protection area and the elongate apertures.

(21) Appl. No.: **10/535,250**

(22) PCT Filed: **Nov. 18, 2003**

(86) PCT No.: **PCT/SE03/01789**

**Related U.S. Application Data**

(60) Provisional application No. 60/319,749, filed on Dec. 3, 2002.

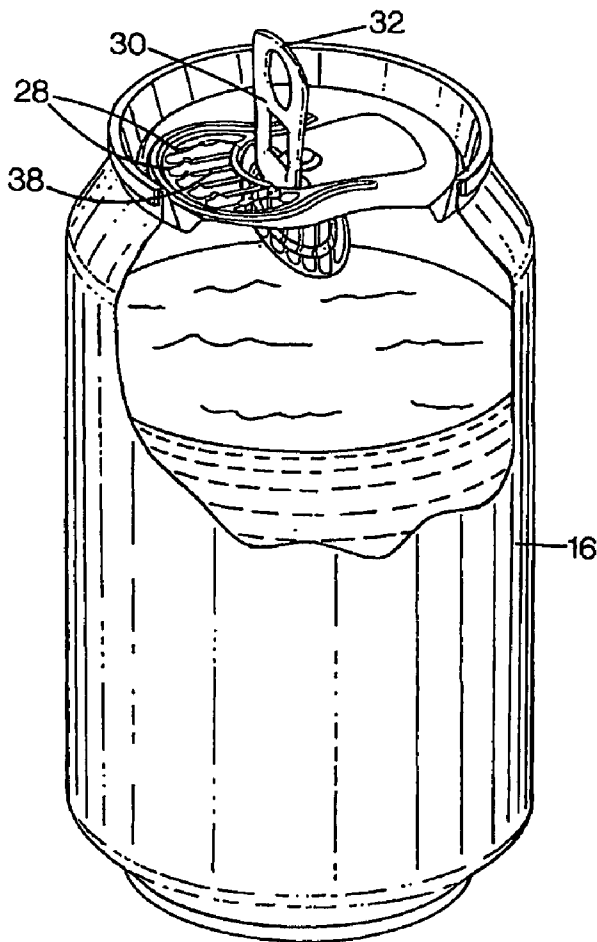

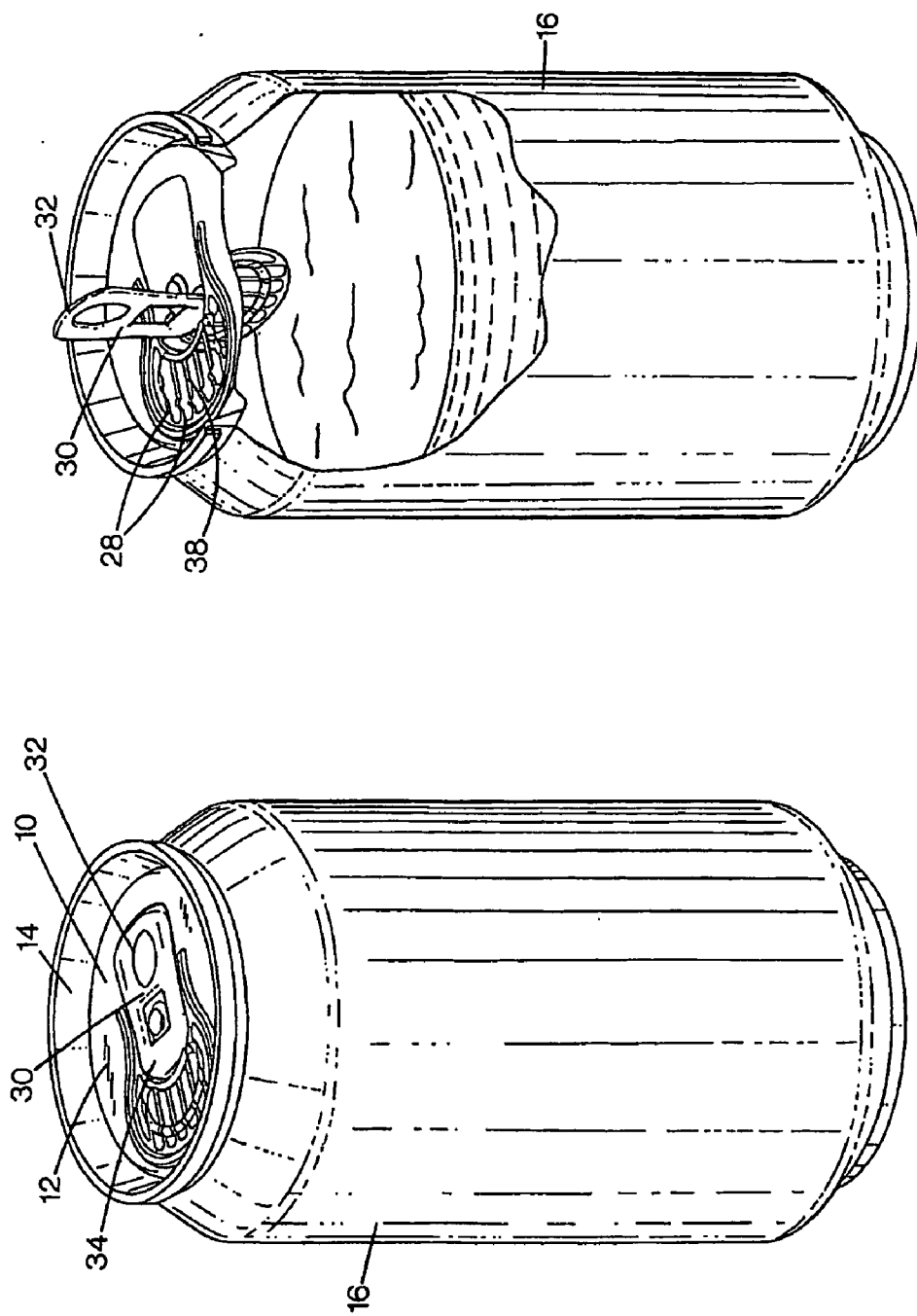

FIG. 2

FIG. 1

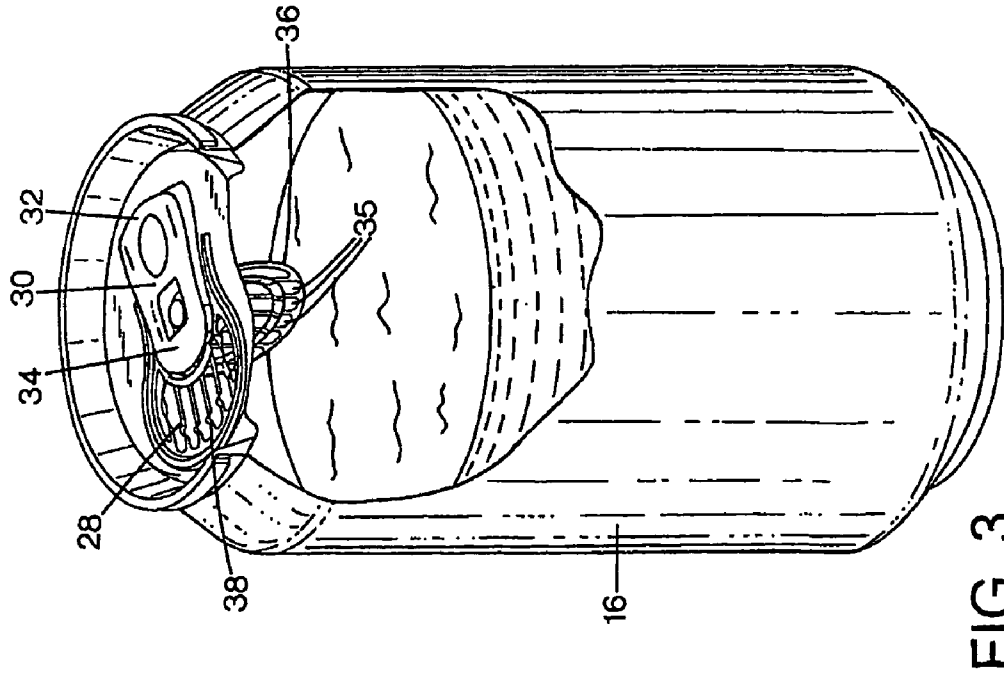
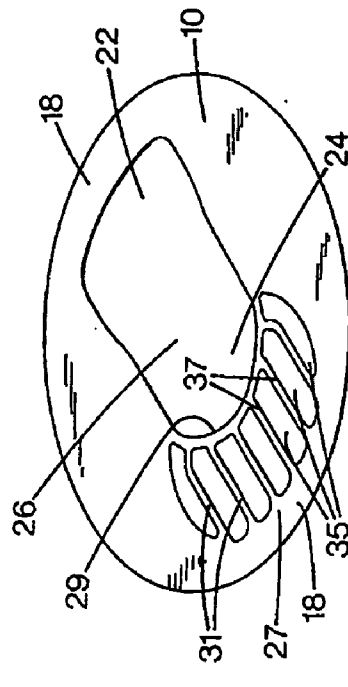
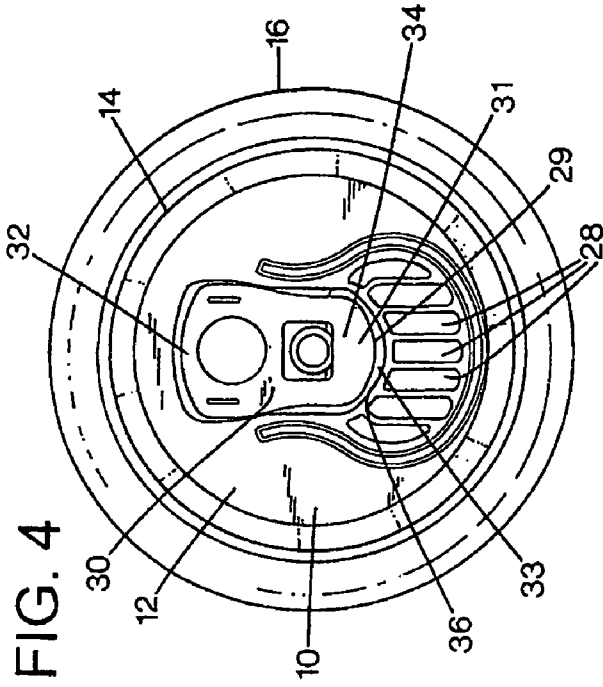

FIG. 4

FIG. 5

FIG. 3

FIG. 6

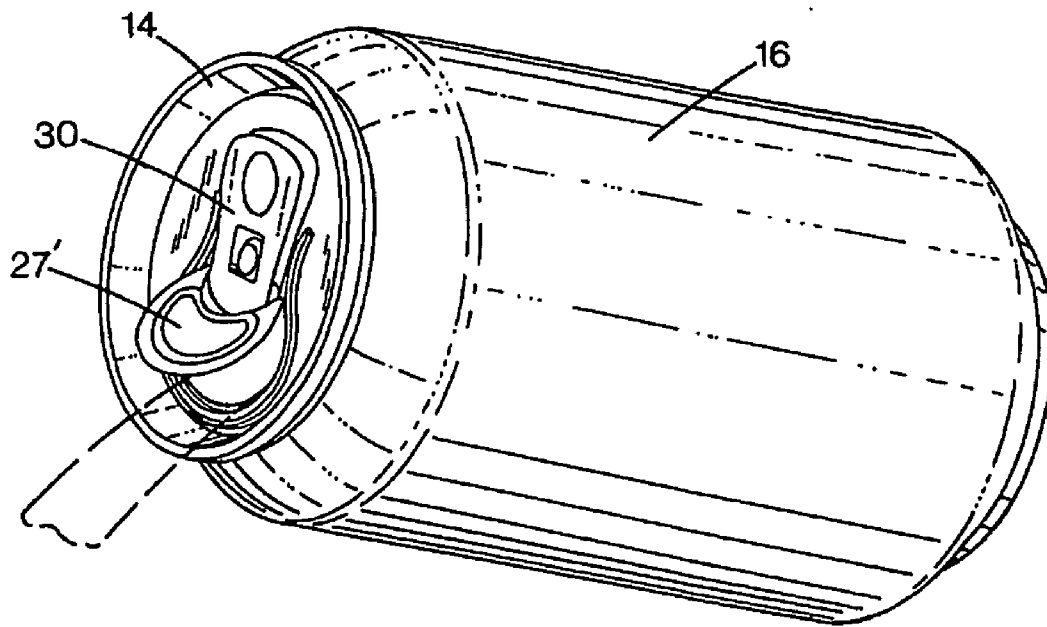
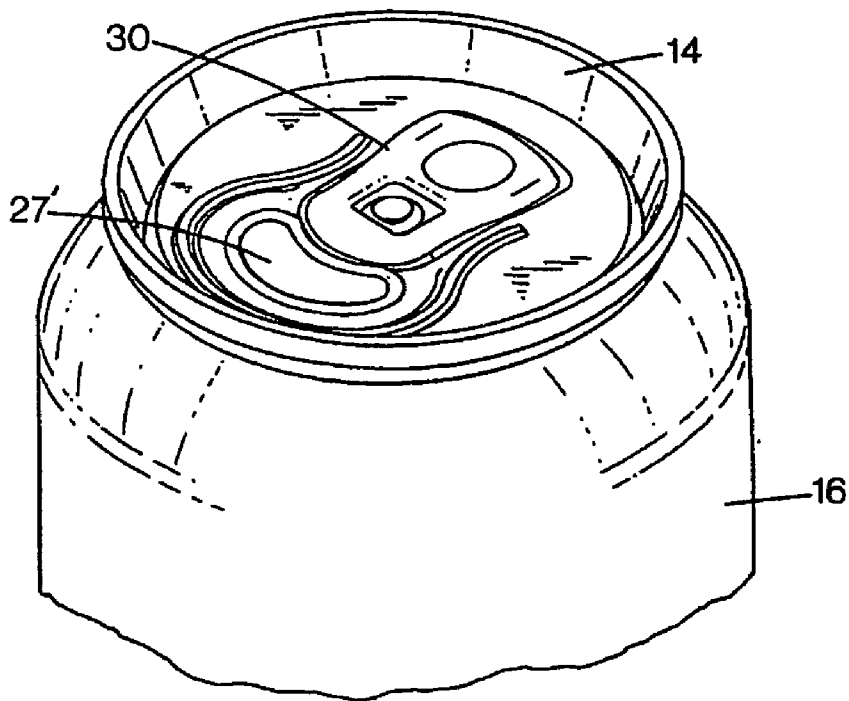

FIG. 7

## METHOD FOR PROTECTING BEVERAGE CAN FROM INSECTS

### BACKGROUND OF INVENTION

[0001] Beverage cans are often commonly used today both for storing beverages and for drinking the beverage directly from the cans. Because most beverages contain sweeteners and other substances that are attractive to insects, insects are drawn to the opening of the beverage cans. A particular problem is that insects may fall into the beverage can without the user knowing about it. It is often very difficult to determine if an insect has fallen into the beverage can because it is difficult to see into the beverage can through the can opening. There is a need for a device and method of preventing insects from entering beverage cans without requiring the user to perform extra tasks to protect the beverage and to preclude insects from falling into the beverage cans.

### SUMMARY OF INVENTION

[0002] The method and device of the present invention provides a solution to the above-outlined problems. More particularly, the method is for preventing insects from entering an opening of a beverage can. The method provides for a beverage can that has a lever member with a handle member and an engaging member attached to a top surface of the beverage can. A cover member is placed on top of the top surface so that a protection area is placed above a weakened segment of the top surface and an inner opening segment is placed below the engaging member. The protection area has a plurality of elongate apertures defined therein. With the protecting area and the apertures placed on top of the weakened segment, the handle member is lifted to move the engaging member through the inner opening segment to push a portion of the weakened segment into the beverage can and creating an opening disposed below the protection area and the elongate apertures.

### BRIEF DESCRIPTION OF DRAWING

[0003] FIG. 1 is a perspective view of the cover member attached to the beverage can;

[0004] FIG. 2 is a perspective view of the cover member attached to the beverage can when the can is opened;

[0005] FIG. 3 is a perspective view of the cover member attached to the opened beverage can with the leverage push back;

[0006] FIG. 4 is a top view of the cover member attached to the beverage can;

[0007] FIG. 5 is a perspective view of the cover member shown in FIG. 1;

[0008] FIG. 6 is a perspective top view of an alternative embodiment of the present invention; and

[0009] FIG. 7 is a perspective side view of the alternative embodiment shown in FIG. 6.

### DETAILED DESCRIPTION

[0010] With reference to FIGS. 1-5, a circular cover member 10 of the present invention may be placed on a top surface 12 and within a projecting flange 14 of a beverage

can 16 to prevent and preclude insects and other undesirable objects from entering into the beverage can 16.

[0011] The cover member 10 is preferably very thin and has an outside peripheral segment 18 that is dimensioned to fit inside the projecting flange 14. The cover member 10 may either be mounted on the can 16 after the can has been manufactured or preferably, to the top surface 12 of the lid before the lid is attached to the can 16.

[0012] The cover member 10 has an opening 20 defined therein. The cover member 10 may also be provided without the opening 20. The opening 20 may be divided into an outer opening segment 22 and an inner opening segment 24 where the segment 22 may be wider than the segment 24. Of course, the segment 22 may be the same or narrower than the segment 24 also. Preferably, the opening segment 24 extends over a central point 26 of the circular cover member 10. The cover member 10 has a protection area 27 that has a plurality of elongated apertures that are pre-cut along strips 31 so that elongate openings 28 (as best shown in FIGS. 2/3) are created when the the inner portions 35 follows the weakened section 36 of the can opener 30 that is pushed into the can 16, as described below. The apertures 28 or segments 35 may extend from a peripheral segment 18 towards the central point 26 and the opening segment 24. The apertures 28 may be substantially parallel and are sufficiently narrow to prevent most insects from passing through the apertures 28.

[0013] The beverage can 16 may have a lever member 30 including a handle portion 32 and an engaging portion 34. When the handle portion 32 is raised away from the top surface 12, as best shown in FIG. 2, the engaging portion 34 is turned downwardly and pushes the weakened section 36 of the top surface 12 into the beverage can 16 to create an opening 38 through the surface 12. Through the opening 38, the user may drink the beverage contained in the beverage can 16.

[0014] Prior to opening the beverage can 16, the cover member 10 may be positioned or adhered to the top surface 12. The protective area 27 is placed over the weakened section 36 of the top surface 12 that defines the opening 38 when the can is opened. The wider opening segment 22 is placed below the handle portion 32 and the opening segment 24 is placed below the engaging portion 34.

[0015] An important feature of the present invention is that the beverage can 16 can be opened without damaging or moving the cover member 10. It is therefore important that the opening 20 is sufficiently large to permit the engaging portion 34 to engage the weakened section 36 without damaging the protection area 27 of the cover member 10. The opening segment 24 should therefore be sufficiently large to cover the entire engaging portion 34. When the engaging portion 34 engages the weakened segment 36 no part of the cover member 10 is affected although the protecting area 27 extends over the segment 36. The protecting area 27 has an inner edge 29 that defines a portion of the opening segment 24. Preferably, the inner edge 29 should be aligned with an outer end 31 of the engaging portion 34 so that when the engaging portion 34 engages the weakened segment 36, the outer end 31 and the inner edge 29 define a narrow gap 33. The outer end 31 may almost touch the inner edge 29 of the cover 10 because the gap 33 should be sufficiently narrow to prevent insects from falling into the

can 16. In this way, the user may open the beverage can 16 with the lever member 30 the same way as if the cover member 10 was not adhered to the top surface 12.

[0016] If the protecting area 27 is glued to the weakened segment 36 that is pushed into the can 16, it is important that the adhesive is not too strong and the material of the cover member 10 is sufficiently sturdy. It is also important that the glue that holds the inside of the cut-out segments 35 is stronger than the glue of the separation portions 37 of the protecting area 27 so that the cut-outs follow the weakened section 36 of the top surface 12 into the can 16 when the can is opened. In this way, the cover member 10 is released from the weakened segment 36 and the cut-out segments 35 follow the segment 36 when the segment 36 is pushed into the can 16 to form the opening 38 of the surface 12 that is covered by the protecting area 27 with the segments 35 removed therefrom to form the apertures 28. Preferably the protecting area 27 is glued to the weakened segment 36 also to prevent dirt from gathering under the cover member 10.

[0017] It is also possible to produce the cover 10 without the opening 20 so that the cover 10 is mounted on the top surface 12 before the lever member 30 is mounted on the top surface 12.

[0018] With reference to FIGS. 6-7, the cover 10 may include a spring biased protecting area 27' that opens only when the user pours the drink and then return to a closed position when the pouring stops or the can 16 is returned to the upright position. In this way, insect cannot get into the can 16 through the opening when the can is in the upright position.

[0019] While the present invention has been described in accordance with preferred compositions and embodiments, it is to be understood that certain substitutions and alterations may be made thereto without departing from the spirit and scope of the following claims.

1. A method for preventing insects from entering an opening of a beverage can, comprising:

providing a beverage can (16) having a lever member (30) with a handle member (32) and an engaging member (34) attached to a top surface (12) of the beverage can (16), a cover member (10) placed on top of top surface (12) so that a protection area (27) is placed above a weakened segment (36) of the top surface (12) and an inner opening segment (24) is placed below the engaging member (34), the protection area (27) having a plurality of elongate apertures (28) defined therein;

with the protecting area (27) and the apertures (28) placed on top of the weakened segment (36), lifting the handle member (32) to move the engaging member (34) through the inner opening segment (24) to engage the weakened segment (36); and

pushing a portion of the weakened segment (36) into the beverage can (16) and creating an opening (38) disposed below the protection area (27) and the elongate apertures (28).

2. The method according to claim 1 wherein the method further comprises adhering the cover member (10) to the top surface (12).

3. The method according to claim 1 wherein the method further comprises providing the cover member 10 with outer ends (19, 21).

4. The method according to claim 1 wherein the method further comprises providing the cover member (10) with an opening (20) that has a shape that is similar to a shape of the lever member (30).

5. The method according to claim 1 wherein the method further comprises moving an outer end (31) immediately adjacent to an inner edge (29) of the cover member (10).

6. The method according to claim 1 wherein the method further comprises separating the protecting area (27) from the weakened segment (36) when the weakened segment (36) is pushed into the can by the engaging portion (34).

\* \* \* \* \*