



(12) **DEMANDE DE BREVET CANADIEN
CANADIAN PATENT APPLICATION**

(13) **A1**

(22) Date de dépôt/Filing Date: 2021/06/16
(41) Mise à la disp. pub./Open to Public Insp.: 2022/01/29
(30) Priorité/Priority: 2020/07/29 (US63/057,944)

(51) Cl.Int./Int.Cl. *B64C 1/06* (2006.01),
B64F 5/10 (2017.01)
(71) Demandeur/Applicant:
THE BOEING COMPANY, US
(72) Inventeurs/Inventors:
BEHZADPOUR, FOROUZAN, US;
ASHMAWI, WAEIL M., US;
APDALHALIEM, SAHRUDINE, US
(74) Agent: SMART & BIGGAR LLP

(54) Titre : SURFACES MOBILES RAIDIES AU MOYEN DE PERLES
(54) Title: BEAD-STIFFENED MOVABLE SURFACES

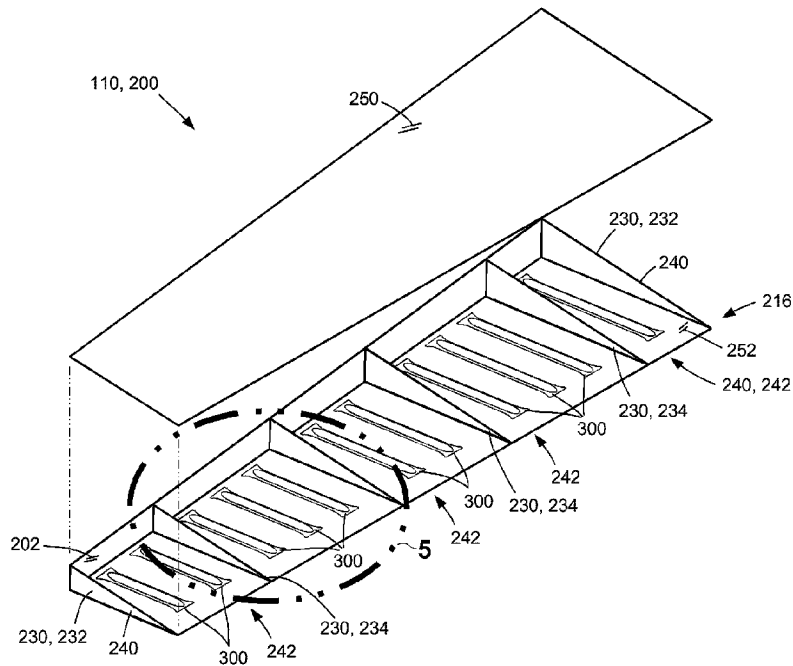

(57) **Abrégé/Abstract:**

A movable surface of an aircraft has a front spar extending along a spanwise direction between opposing movable surface ends. The movable surface also includes a plurality of ribs defining a plurality of bays between adjacent pairs of the ribs. Each rib extends between the front spar and a trailing edge portion of the movable surface. The movable surface further includes an upper and a lower skin panels coupled to the ribs and the front spar. In addition, the movable surface includes a plurality of bead stiffeners coupled to an inner surface of at least one of the upper skin panel and the lower skin panel. The bead stiffeners within the bays are spaced apart from each other and are oriented non-parallel to the front spar and have a bead stiffener cap having opposing cap ends respectively locate proximate the front spar and the trailing edge portion.

ABSTRACT

A movable surface of an aircraft has a front spar extending along a spanwise direction between opposing movable surface ends. The movable surface also includes a plurality of ribs defining a plurality of bays between adjacent pairs of the ribs. Each rib
5 extends between the front spar and a trailing edge portion of the movable surface. The movable surface further includes an upper and a lower skin panels coupled to the ribs and the front spar. In addition, the movable surface includes a plurality of bead stiffeners coupled to an inner surface of at least one of the upper skin panel and the lower skin panel. The bead stiffeners within the bays are spaced apart from each other and are
10 oriented non-parallel to the front spar and have a bead stiffener cap having opposing cap ends respectively located proximate the front spar and the trailing edge portion.

BEAD-STIFFENED MOVABLE SURFACES

FIELD

The present disclosure relates generally to movable surfaces of an aircraft and, more particularly, to a movable surface having skin panels that are stiffened with discrete bead stiffeners.

BACKGROUND

Aircraft typically include several types of flight control surfaces (i.e., movable surfaces) for controlling the direction and orientation of the aircraft during flight. For example, the wings of an aircraft may include ailerons for roll control of the aircraft about a longitudinal axis. The ailerons may be pivotably coupled to the wings, and may be deflected up and/or down to rotate the aircraft about the longitudinal axis for changing the bank angle of the aircraft to initiate a turn, or to return the aircraft to a wings-level orientation. The tail portion of an aircraft may include an elevator for pitch control of the aircraft about a lateral axis. An elevator may be pivotably coupled to a horizontal stabilizer, and may be deflected up and down to rotate the aircraft about the lateral axis for changing the pitch angle of the aircraft to a nose-up or nose-down orientation for respectively climbing or descending. The tail portion may also include a rudder for yaw control of the aircraft about a vertical axis. The rudder may be pivotably coupled to a vertical stabilizer, and may be deflected right and left to rotate the aircraft about the vertical axis for controlling the yaw orientation of the aircraft in coordination with deflection of the ailerons during turning of the aircraft.

Conventionally, flight control surfaces (i.e., movable surfaces) are manufactured in one of several different structural arrangements. For example, one structural arrangement for an aileron may be described as a honeycomb-sandwich arrangement in which composite (e.g., carbon-fiber) upper and lower skin panels are interconnected by a full-depth honeycomb core. Although the honeycomb-sandwich arrangement provides for a high-strength structure, the honeycomb core presents challenges

associated with manufacturing and repairability. Another example of a structural arrangement for a movable surface (e.g., an aileron) is a multi-rib arrangement that combines the use of titanium and composite materials. Although providing for a high-strength structure, the multi-rib arrangement is heavy, complex, and time-consuming to manufacture due to the large number of parts and the different types of assembly operations that are required due to the mixed use of materials. In addition, the multi-rib arrangement presents challenges associated with repairability. For example, repair of a movable surface having a multi-rib arrangement may entail replacement of the entire movable surface.

As can be seen, there exists a need in the art for a movable surface (e.g., a flight control surface) that avoids the above-mentioned challenges associated with the manufacturing, repairability, and weight of conventional movable surfaces.

SUMMARY

The above-noted needs associated with movable surfaces of an aircraft are specifically addressed by the present disclosure which provides a movable surface having a front spar that extends along a spanwise direction between opposing movable surface ends. In addition, the movable surface includes a plurality of ribs located at spaced intervals between the movable surface ends and which define a plurality of bays between adjacent pairs of the ribs. Each rib extends between the front spar and a trailing edge portion of the movable surface. The movable surface also includes an upper skin panel and a lower skin panel coupled to the plurality of ribs and the front spar. Additionally, the movable surface includes a plurality of bead stiffeners coupled to an inner surface of at least one of the upper skin panel and the lower skin panel. The bead stiffeners within the bays are spaced apart from each other and are oriented non-parallel to the front spar and have a bead stiffener cap having opposing cap ends respectively locate proximate the front spar and the trailing edge portion.

Also disclosed is a method of manufacturing a movable surface of an aircraft. The method includes coupling a plurality of ribs to a front spar of the movable surface. As

mentioned above, each rib extends between the front spar and a trailing edge portion of the movable surface. The front spar extends along a spanwise direction between opposing movable surface ends of the movable surface. The ribs are located at spaced intervals between the movable surface ends and define a plurality of bays between adjacent pairs of the ribs. The method further includes coupling a plurality of bead stiffeners to an inner surface of at least one of an upper skin panel and a lower skin panel of the movable surface. The bead stiffeners within one or more of the bays are spaced apart from each other, and have a bead stiffener cap having opposing cap ends respectively located proximate the front spar and the trailing edge portion. The method also includes coupling the upper skin panel and the lower skin panel to the plurality of ribs and to the front spar.

In addition, disclosed is a method of loading a movable surface of an aircraft. The method includes providing a movable surface as described above. The method additionally includes placing the movable surface in a non-loaded condition, and placing the movable surface in a loaded condition. The non-loaded condition is associated with the aircraft being substantially non-moving and under a ground static loading in which the movable surface is subjected to gravitational force due to a structural mass of the movable surface. The loaded condition is associated with the aircraft in motion in which the movable surface is subjected to loads such as aerodynamic loads and/or loads due to gravitational force or inertial force due to the structural mass of the movable surface.

The features, functions and advantages that have been discussed can be achieved independently in various embodiments of the present disclosure or may be combined in yet other embodiments, further details of which can be seen with reference to the following description and drawings below.

25

BRIEF DESCRIPTION OF THE DRAWINGS

These and other features of the present disclosure will become more apparent upon reference to the drawings wherein like numbers refer to like parts throughout and wherein:

- Figure 1 is a perspective view of an example of an aircraft having one or more composite movable surfaces as presently-disclosed;
- Figure 2 is a sectional view of an example of a wing of the aircraft taken along line 2-2 of Figure 1 and showing an example of the movable surface in the form of an aileron pivotably coupled to the wing;
- 5 Figure 3 is a top-down view of the aileron of Figure 2;
- Figure 4 is a partially-exploded perspective view of the aileron of Figure 3 showing the upper skin panel separated from the aileron;
- Figure 5 is a magnified view of the portion of the aileron identified by reference numeral 5 of Figure 4, and showing a plurality of discrete bead stiffeners coupled to an inner surface of the lower skin panel within a bay defined between two of the ribs of the aileron;
- 10 Figure 6 is a top-down view of the portion of the aileron identified by reference numeral 6 of Figure 5, and showing a portion of a bead stiffener and a rib coupled to the lower skin panel and the front spar of the aileron;
- 15 Figure 7 is a sectional view of a portion of the aileron taken along line 7-7 of Figure 6, and showing an example of a wing rib, upper and lower skin panels, and one of the bead stiffeners;
- Figure 8 is a sectional view of a further example of a bead stiffener having a bead width and a bead height that is different than the bead width and bead height of the bead stiffener of Figure 7;
- 20 Figure 9 is a spanwise sectional view of the aileron taken along line 9-9 of Figure 3, and showing three bead stiffeners coupled to each of the upper and lower skin panels within one bay of the aileron, and further showing on each of the upper and lower skin panels an example of a bead-skin portion cross-sectional area corresponding to a combined skin-bead bending stiffness of a skin panel portion and associated bead stiffener;
- 25 Figure 10 is a chordwise sectional view of the aileron taken along line 10-10 of Figure 3, and showing a bead stiffener coupled to each of the upper skin

panel and lower skin panels, and further showing the upper and lower skin panels coupled to the front spar at a forward portion of the aileron, and showing the upper and lower skin panels coupled to each other at a trailing edge portion of the aileron;

- 5 Figure 11 is a magnified view of the portion of the aileron identified by reference numeral 11 of Figure 10, and illustrating an example of a front spar having 0-degree plies interleaved within the fabric plies of the spar outer flanges;
- Figure 12 is an assembled sectional view of an example of a hybrid configuration of the front spar having upper and lower spar chords interconnected by a spar web;
- 10 Figure 13 is a disassembled view of the front spar of Figure 12;
- Figure 14 is a magnified view of the portion of the aileron identified by reference numeral 14 of Figure 10, and illustrating an example of a trailing edge spacer installed between the upper and lower skin panels at the trailing edge portion;
- 15 Figure 15 is an assembled sectional view of a further example of the trailing edge portion having a rear spar to which the upper and lower skin panels are coupled, and further showing a trailing edge wedge configured to be removably attachable to the rear spar;
- 20 Figure 16 is a disassembled view of the example of the trailing edge portion of Figure 15;
- Figure 17 is a flowchart of a method of manufacturing a movable surface of an aircraft;
- Figure 18 is a flowchart of a method of loading a movable surface of an aircraft.

25

DETAILED DESCRIPTION

Referring now to the drawings which illustrate various examples of the disclosure, shown in Figure 1 is a perspective view of an example of an aircraft 100 having one or more composite flight control surfaces, referred to herein as movable surfaces 200. The

aircraft **100** includes a fuselage **106**, a pair of wings **108** extending outwardly from the fuselage **106**, and an empennage **114** at the aft end of the fuselage **106**. In the present disclosure, the wings **108** may be referred to as aerodynamic members **102**, and may include one or more movable surfaces **200** including, but not limited to, ailerons **110**, flaps **112**, and other movable surfaces **200**. The empennage **114** includes a vertical tail comprising a vertical stabilizer **116** (i.e., the aerodynamic member **102**) and a movable surface **200** configured as a rudder **118** pivotably coupled to the vertical stabilizer **116**. The empennage **114** may additionally include a horizontal tail comprising horizontal stabilizers **120** each having an elevator **122** pivotably coupled to the horizontal stabilizer **120**. In the present disclosure, horizontal stabilizers **120** may be referred to as aerodynamic members **102**. Although described in the context of an aileron **110**, the presently-disclosed movable surface **200** may be provided in any one of a variety of alternative configurations, and is not limited to an aileron **110**, a rudder **118**, or an elevator **122**.

Advantageously, the movable surface **200** (see Figure 2) is configured in an arrangement that results in a low-cost, high-strength, light-weight structure with high fatigue-loading performance. The movable surface **200** includes upper and lower skin panels **250**, **252** each having a plurality of discrete bead stiffeners **300** for stiffening the skin panels **250**, **252** in a cost-effective and structurally efficient manner. In addition, the movable surface **200** has a relatively small part count and a common material system (e.g., composite material) which allows the movable surface **200** to be manufactured at high production rates and at low cost. As described below, the movable surface **200** may be configured in an arrangement that avoids the above-mentioned repairability challenges associated with conventional movable surfaces **200** having a honeycomb-sandwich construction or a multi-rib construction.

Referring to Figures 2-5, shown is an example of the movable surface **200** configured as an aileron **110**, and having a front spar **202**, a plurality of ribs **230**, and an upper skin panel **250** and a lower skin panel **252**. In the example shown, the front spar **202** may be formed of composite material and may have a channel-shaped cross

section. However, in other examples not shown, the front spar **202** may have a cross-sectional shape other than a channel-shaped cross-section. The front spar **202** extends along a spanwise direction between opposing movable surface ends **240**.

Referring to Figure **2**, the movable surface **200** may include a plurality of attach fittings **124** mounted to the front spar **202** for coupling the movable surface **200** (e.g., an aileron **110**) to an aerodynamic member **102** (e.g., a wing **108**). In the example shown, the attach fittings **124** are configured as hinge fittings **126** for allowing the aileron **110** to be pivotably deflected upwardly and downwardly. A rudder **118** (Figure **1**) may also include hinge fittings **126** for pivotably coupling the rudder **118** to a vertical stabilizer **116** (Figure **1**). Likewise, an elevator **122** (Figure **1**) may include hinge fittings **126** for pivotably coupling the elevator **122** to a horizontal stabilizer **120** (Figure **1**). However, a movable surface **200** may include attach fittings **124** having a non-pivoting configuration. For example, in the case where the movable surface **200** is a flap **112**, the attach fittings **124** may be configured as flap tracks (not shown) coupling the flap **112** to a wing aft portion. Such flap tracks may be configured to translate the flap **112** aftwardly while simultaneously pivoting the trailing edge of the flap **112** downwardly as the flap **112** is moved from a retracted position to an extended position.

Referring to Figures **4-7**, the movable surface **200** includes a plurality of ribs **230** located at spaced intervals between the movable surface ends **240** and defining a plurality of bays **242** between adjacent pairs of the ribs **230**. Each rib **230** may be formed of composite material, and extends between the front spar **202** and a trailing edge portion **216** of the movable surface **200**. Each of the ribs **230** may be oriented generally parallel to a chordwise direction or streamwise direction of the movable surface **200**, and which may be generally parallel to a longitudinal axis **104** (Figure **1**) of the aircraft **100** (Figure **1**). A pair of the ribs **230** may be configured as closeout ribs **232** located respectively at the opposing movable surface ends **240**. The ribs **230** may also be configured as intermediate ribs **234** located at spaced intervals between the closeout ribs **232**. In the example shown, the ribs **230** are spaced at non-uniform intervals between the closeout ribs **232**. In an example not shown, the intermediate ribs **234** may

be spaced at uniform intervals between the closeout ribs **232**. The spanwise location of each of the ribs **230** may be based at least in part on the distribution of load on the movable surface **200**. The intermediate ribs **234** may be located at the same spanwise location as the attach fittings **124** that couple the movable surface **200** (e.g., aileron) to the aerodynamic member **102** (e.g., wing).

As mentioned above, the movable surface **200** includes an upper skin panel **250** and a lower skin panel **252** each comprised of composite material. The upper skin panel **250** and lower skin panel **252** may each extend in a spanwise direction between the movable surface ends **240**, and in a chordwise direction between the front spar **202** and the trailing edge portion **216**. In this regard, the aft portion of the upper and lower skin panels **250**, **252** may define the trailing edge portion **216** of the movable surface **200**. The upper skin panel **250** and the lower skin panel **252** may be coupled to the ribs **230** and the front spar **202** via bonding and/or mechanical fasteners **450**.

Referring still to Figures **4-7**, the movable surface **200** includes a plurality of bead stiffeners **300** coupled to the inner surface of the upper skin panel **250**, and a plurality of bead stiffeners **300** coupled to the lower skin panel **252**. As mentioned above, the bead stiffeners **300** increase the chordwise bending stiffness of the skin panels **250**, **252**, and thereby assist the skin panels **250**, **252** in resisting pressure loads due to aerodynamic pressure on the movable surface **200**. Each of the bead stiffeners **300** is comprised of composite material and may be bonded and/or mechanically fastened to the skin panels **250**, **252**. Within each bay **242** (Figure **4**), the upper skin panel **250** and/or the lower skin panel **252** has at least one bead stiffener **300** mounted to the upper skin panel **250** or lower skin panel **252**. More preferably, the portion of each skin panel within each bay **242** has two or more bead stiffeners **300**. In the example of Figure **3**, each bay **242** has from **1** to **3** bead stiffeners **300** coupled to the upper skin panel **250** and/or to the lower skin panel **252**. However, a skin panel **250**, **252** may include any number of bead stiffeners **300** within a bay **242** of the movable surface **200**.

As mentioned above, the components of the movable surface **200** are formed of composite material. The composite material used in manufacturing the movable surface

200 may be in the form of composite plies **400** (see, e.g., Figures **7-8**) of fiber-reinforced polymer matrix material (e.g., carbon fibers pre-impregnated with epoxy resin material). The composite plies **400** (i.e., prepreg) may be laid up in a stacked formation and cured to form a composite laminate in the form of the front spar **202** (Figure **7**), the optional trailing edge spacer **218** (Figure **14**), the optional rear spar **204** (Figures **15-16**) and trailing edge wedge **220** (Figures **15-16**), the upper skin panel **250** (Figure **7**) and lower skin panel **252** (Figure **7**), and the bead stiffeners **300** (Figure **7**). Each composite ply may have a thickness of **0.005** inch or more. The polymer matrix material of the composite plies **400** may be a thermosetting resin or a thermoplastic resin. The fibers of the composite plies **400** may be carbon fibers or the fibers may be formed of alternative materials such as glass, boron, aramid, ceramic or other non-metallic materials or metallic materials. Advantageously, movable surfaces **200** formed of composite material have improved corrosion resistance and improved fatigue strength relative to the corrosion resistance and fatigue strength of movable surfaces formed of metallic materials (e.g., aluminum).

The composite plies **400** (Figure **7**) of a component of the movable surface **200** (Figure **7**) may be unidirectional plies **404** (Figure **7**) and/or fabric plies **402** (Figure **7**). For example, the upper skin panel **250** (Figure **7**) and/or the lower skin panel **252** (Figure **7**), and the trailing edge spacer **218** (Figure **14**) may be comprised primarily of unidirectional plies **404**. Each unidirectional ply may contain a plurality of generally parallel fibers oriented in a single direction. The unidirectional plies **404** of a skin panel **250**, **252** may include **0-degree** plies **406** (Figure **7**), **+45-degree** plies, **-45-degree** plies, and **90-degree** plies, and/or other fiber orientations. Other components of the movable surface **200** may be comprised primarily of fabric plies **402**. For example, the front spar **202** (Figure **11**), the ribs **230** (Figure **11**), the rear spar **204** (Figures **15-16**), and/or the trailing edge wedge **220** (Figures **15-16**) may be comprised primarily of fabric plies **402**. In the present disclosure, a fabric ply **402** may be described as having multi-directional fibers. For example, a fabric ply **402** may include a woven arrangement of bi-directional fibers wherein the fibers are oriented perpendicular to each other.

The bead stiffeners **300** (Figure **4**) may be oriented generally parallel (e.g., ± 20 degrees) to each other, and are non-parallel to the front spar **202** (Figure **4**). In one example, the bead stiffeners **300** may be oriented parallel or generally parallel to the ribs **230** (Figure **4**). The bead stiffeners **300** within one or more of the bays **242** may be spaced apart at a spanwise spacing **316** (Figure **5**) of **6-11** inches. In other examples, the bead stiffeners **300** may be spaced apart at a spanwise spacing **316** of **7.5-9.5** inches. The spanwise spacing **316** between the bead stiffeners **300** may be dictated by the stiffness requirements of the skin panel, which may be dictated by the predicted maximum aerodynamic pressure loads on the skin panel during flight, as described in greater detail below.

Referring to Figures **7-8** bead stiffener **300** has opposing bead stiffener flanges **302** interconnected by a bead stiffener cap **304**. In this regard, each bead stiffener flange **302** may be connected to the bead stiffener cap **304** by a radius portion **212**. The bead stiffener flanges **302** extend lengthwise along the sides of the bead stiffener **300**. The bead stiffener flanges **302** may additionally extend across each of the opposing ends of the bead stiffener **300**, as shown in Figures **5-6**.

As shown in Figures **5-6**, each bead stiffener **300** has a cap end **306** at each end of the bead stiffener **300**. The cap ends **306** may be closed to improve the torsional stiffness of the bead stiffener **300** relative to the torsional stiffness of the bead stiffener **300** if the cap ends **306** were open. A drain hole **308** may be included in one or both of the cap ends **306** to allow moisture and/or contaminants to be flushed out of the bead stiffener cavity **310**. Each bead stiffener **300** may be mounted to a skin panel **250**, **252** such that the cap ends **306** are respectively located proximate the front spar **202** and the trailing edge portion **216**. For example, the cap end **306** at one end of a bead stiffener **300** may be located within **1** inch of the front spar **202**, and the cap end **306** at an opposite end of the bead stiffener **300** may be located within **2** inches of the aftermost edge of the trailing edge portion **216**.

The bead stiffener flanges **302** may be bonded to a skin panel and/or coupled to the skin panel via mechanical fasteners **450**. As shown in Figures **5-6**, bead stiffener

flanges **302** may be locally flared or widened at each end of the bead stiffener **300** to provide additional surface area over which peel stress in the bondline (e.g., adhesive layer) may be distributed into the skin panel **250, 252**. In this regard, the flaring of the bead stiffener flanges **302** at the ends may reduce the peel stress in the bondline, and
5 may thereby minimize or prevent the occurrence of cracking in the bondline (e.g., adhesive layer), and which may otherwise propagate along the length of the bead stiffener **300**, potentially resulting in the separation of the bead stiffener **300** from the skin panel and/or loss of the stiffness contribution of the bead stiffener **300** to the skin panel **250, 252**.

10 Referring to Figure 7, the bead stiffener cap **304** may have a rounded cross-sectional shape. For example, Figure 7 shows an example of a bead stiffener **300** having a semi-elliptical cross-sectional shape. However, in other examples, the bead stiffeners **300** may have a semi-circular cross-sectional shape or a semi-oval cross-sectional shape. The bead stiffener cap **304** may have a bead width **318** and a bead
15 height **320**. In some bead stiffener **300** examples, the ratio of the bead width **318** to bead height **320** may be no less than 2. The bending load capability (i.e., the bead stiffness) of the bead stiffener **300** in the chordwise direction may be a function of the bead width **318**, the bead height **320**, and/or the radius of curvature of the bead stiffener cap **304**.

20 The bead stiffener cap **304** may be generally hollow and may define a bead stiffener cavity **310**. The bead stiffener cap **304** of each bead stiffener **300** may have a cross section that is constant along a lengthwise direction of the bead stiffener **300**, and which may simplify manufacturing of the bead stiffeners **300**. In some examples, each bead stiffener **300** of the movable surface **200** may have the same cross-sectional
25 shape, same cross-sectional size, and/or same thickness. Even further, each bead stiffener **300** may have the same quantity of composite plies **400** arranged in the same ply stacking sequence. However, to accommodate movable surfaces **200** that have a tapering width, the bead stiffeners **300** may be provided in different lengths

complementary to the different widths of the movable surface **200** at different spanwise locations.

Referring to Figure **8**, in some examples, the bead stiffener cavity **310** may contain a foam member **312** which may fill the bead stiffener cavity **310**. The foam member **312** may be contoured complementary to a final shape of the bead stiffener, and may thereby function as a tool or mandrel over which the bead stiffener **300** may be laid up and cured. In some examples, the foam member **312** may be retained within the bead stiffener cavity **310** after the bead stiffener **300** has been cured and attached (e.g., bonded and/or mechanically fastened) to the skin panel. By occupying the bead stiffener cavity **310**, the foam member **312** may increase the bead ending stiffness of the bead stiffener **300**. The foam material of the foam member **312** may be a lightweight, closed cell foam. The foam material may have a density in the range of **3-15** pounds per cubic feet.

As mentioned above, the bead stiffeners **300** may be laid up using a quantity of fabric plies **402** that provide the desired level of bead bending stiffness. In one example, each bead stiffener **300** may include from **4-6** fabric plies **402**, and may be devoid of unidirectional plies **404**. The use of fabric plies **402** may improve the formability of the highly curved surfaces that define the bead stiffener **300**, and may avoid warpage and/or wrinkling associated with unidirectional plies **404** used in curved components. The bead stiffeners **300** may be configured to be compatible with the skin panels **250**, **252** with regard to bending stiffness and axial stiffness. The bead stiffeners **300** and skin panels **250**, **252** may be manufactured and assembled using one of several different manufacturing methods. In one example, the bead stiffeners **300** may be separately laid up and co-bonded with a cured skin panel **250**, **252**. In another example, the bead stiffeners **300** and a skin panel **250**, **252** may be laid up and co-cured in one cure cycle. In still another example, the bead stiffeners **300** may be separately laid up and cured, and then secondary bonded to a cured skin panel **250**, **252** via an adhesive layer. In any one of the above described examples, the bead stiffener flanges **302** may

be mechanically fastened to a skin panel **250, 252** in addition to bonding of the bead stiffener **300** to the skin panel **250, 252**.

Referring briefly again to Figure 7, shown is an example of a rib **230** of the movable surface **200**. The rib **230** has a channel-shaped cross section having a rib web **238** interconnecting an opposing pair of rib flanges **236**. In the example shown, the rib flanges **236** are oriented approximately perpendicular to the rib web **238**. Each rib flange **236** may be connected to the rib web **238** by a radius portion **212**. As mentioned above, a rib **230** may be comprised of fabric plies **402** to avoid warpage of the rib **230** during curing, such as spring-in of the rib flanges **236** toward the rib web **238** which may occur during cool-down of the rib **230** from curing. In the example shown, each rib flange **236** may include one or more 0-degree plies **406** located approximately a mid-plane of the rib flange **236**. The 0-degree plies **406** are excluded from the radius portion **212** and excluded from the rib web **238**. Advantageously, 0-degree plies **406** in the rib flanges **236** may increase the shear strength of the rib flanges **236** in the connection with the upper and lower skin panels **250, 252**.

Referring to Figures 7 and 9, the upper skin panel **250** and the lower skin panel **252** may have a panel thickness **254** that is constant along the chordwise direction between the front spar **202** (Figure 4) and the trailing edge portion **216** (Figure 4), and also constant along the spanwise direction between the opposing movable surface ends **240** (Figure 4) of the movable surface **200**. The constant panel thickness **254** may be achieved by eliminating ply drops (not shown) in the composite plies **400** that make up the skin panels **250, 252**. By eliminating ply drops, manufacturing may be simplified, which may reduce cost and increase the production rate.

Advantageously, the panel thickness **254** of the upper skin panel **250** and lower skin panel **252** may be relatively thin compared to thicker skin panels used in conventional movable surfaces. The relatively thin gauge of the skin panels **250, 252** in the present disclosure results in improved fatigue loading performance (i.e., durability) relative to the reduced fatigue loading performance associated with thicker, heavier skin panels. The relatively thin gauge of the skin panels **250, 252** in the present disclosure is

a result of the use of bead stiffeners **300** for stiffening the skin panels **250**, **252**, and also due to the skin panels **250**, **252** (i.e., with bead stiffeners **300**) being designed to buckle at or above limit load. Limit load may be described as the maximum load expected on the movable surface **200** during service. Designing the skin panels **250**,
5 **252** of the movable surface **200** to buckle at or above limit load is in contrast to the conventional practice of designing skin panels to buckle at or above the higher ultimate load (e.g., limit load multiplied by a safety factor), and which necessitates the use of thicker skin panels in conventional movable surfaces, which increases panel weight and results in higher dynamic loads with reduced fatigue loading performance.

10 Although the panel thickness **254** of the upper and lower skin panels **250**, **252** may be constant, the upper and/or lower skin panel **252** may optionally include localized padup regions (not shown) at the locations where the skin panels **250**, **252** are coupled to the front spar **202**. A padup region may be described as a local increase in the quantity of composite plies **400** on the inner surface of the skin panel **250**, **252**. The skin
15 panels **250**, **252** may include a padup region at the spanwise location of each attach fitting **124** (e.g., hinge fitting **126**). The increased thickness of the skin panel **250**, **252** at the padup regions may facilitate the transfer of loads from the skin panels **250**, **252** into the front spar **202** and into the attach fittings **124** (Figure 3) coupling the movable surface **200** (e.g., aileron) to the aerodynamic member **102** (e.g., wing).

20 Referring to Figure 9, shown is an example of one bay **242** of the aileron **110** of Figure 3, and illustrating a plurality of bead stiffeners **300** coupled to each of the upper skin panel **250** and the lower skin panel **252** within the bay **242**. The bead stiffeners **300** of the movable surface **200** may be configured to flex with the skin panels **250**, **252** during chordwise bending of the skin panels **250**, **252**. Chordwise bending may occur
25 due to out-of-plane loading of the skin panels **250**, **252** in response to aerodynamic pressure on the skin panels **250**, **252**, such as when the movable surface **200** is deflected into the airstream during flight. Configuring the bead stiffeners **300** to flex with the skin panels **250**, **252** may avoid high peel stress in the bondline between the bead stiffener flanges **302** and the inner surface of the skin panels **250**, **252**, and which may

otherwise result in crack initiation within the bondline and/or separation of the bead stiffeners **300** from the skin panels **250, 252**. Toward this end, the bead stiffeners **300** may be specifically configured to have a bead bending stiffness in the chordwise direction that is lower than the combined skin-bead bending stiffness of the skin panels **250, 252** and bead stiffeners **300** in the chordwise direction.

For example, the movable surface **200** may be configured such that each bead stiffener **300** has a bead bending stiffness that is approximately **40-60** percent (more preferably, **45-55** percent) of the combined skin-bead bending stiffness of the bead stiffener **300** and a skin panel portion **256** (i.e., of the upper skin panel **250** or the lower skin panel **252**) supported by the bead stiffener **300** (e.g., Figure **9**). As mentioned above, the bead bending stiffness and the skin bending stiffness are in the chordwise direction. The bead bending stiffness may be measured at the midpoint **258** along the length of the bead stiffener **300**. The skin bending stiffness is the stiffness of the skin panel portion **256** located directly underneath and attached to or supported by the bead stiffener **300**, and may be measured at the same chordwise location as where the bending stiffness of the bead stiffener **300** is measured. Maintaining a **40-60** percent bending stiffness ratio of bead bending stiffness to combined skin-bead bending stiffness may limit the magnitude of peel stress in the bead-skin bondline, while also allowing the bead stiffeners **300** to provide bending stiffness that prevents buckling of the skin panels **250, 252** (i.e., stiffened by the bead stiffeners **300**) when the movable surface **200** is at or below limit load.

As mentioned above, the use of the bead stiffeners **300** allows the skin panels **250, 252** to have a relatively thin gage or panel thickness **254**. The stiffness of the bead stiffeners **300** may limit out-of-plane deflection of the skin panels **250, 252** to a relatively small value (e.g., less than **0.0005** inch) from the as-designed contour of the outer mold line of the skin panels **250, 252**. Limiting out-of-plane deflection of the skin panels **250, 252** may result in natural laminar flow of the airstream over the movable surface **200**, which may improve aerodynamic efficiency by reducing or preventing separation of

airflow from the outer mold line of the movable surface **200**, thereby reducing aerodynamic drag otherwise created by separated turbulent flow.

As mentioned above, each bead stiffener **300** may have a bead bending stiffness that is approximately **40-60** percent of the combined skin-bead bending stiffness of the bead stiffener **300** and a skin panel portion **256** supported by the bead stiffener **300**.
5 The cross-sectional area of one of the bead stiffeners **300** and associated skin panel portion **256** are represented by the crosshatched area in Figure **9**, and identified as the bead-skin portion cross-sectional area **262**. For bead stiffeners **300** that are located between an adjacent pair of bead stiffeners **300**, the skin panel portion **256** has a panel
10 portion width **264** that extends between midpoints **258** respectively located on opposite sides of the bead stiffener **300**. Each midpoint **258** is located midway between the edge of the bead stiffener flange **302** of the bead stiffener **300**, and the edge of the bead stiffener flange **302** of an immediately adjacent bead stiffener **300**, as shown in the upper skin panel **250** of Figure **9**. For bead stiffeners **300** that are located between a rib
15 **230** and another bead stiffener **300**, the panel portion width **264** extends between the rib flange **236** edge or rib web **238** of the rib **230** on one side of the bead stiffener **300** and, on an opposite side of the bead stiffener **300**, the midpoint **258** between the edge of the bead stiffener flange **302** of the bead stiffener **300**, and an immediately adjacent bead stiffener **300**, as shown in the lower skin panel **252** of Figure **9**. In each example,
20 the panel portion width **264** of the skin panel portion **256** is centered on the bead stiffener **300**.

The magnitude of the chordwise skin bending stiffness of a skin panel portion **256** may be dictated at least in part by the ply composition, ply quantity, and ply stacking sequence of the composite plies **400** that make up the skin panel **250**, **252**, and by the
25 panel portion cross-sectional area, which may be a function of the panel portion width **264** and the panel thickness **254**. Similarly, the magnitude of the chordwise (i.e., lengthwise) bead bending stiffness of a bead stiffener **300** may be dictated at least in part by the ply composition, ply quantity, and ply stacking sequence of the composite plies **400** that make up the bead stiffener **300**, and also by the size (e.g., bead width

318, bead height **320**, etc.) and shape (e.g., radius of curvature of the bead stiffener cap **304**) of the bead stiffener cross-sectional area.

In addition to a preferred **40-60** percent bending stiffness ratio of bead bending stiffness to combined skin-bead bending stiffness, the bead stiffeners **300** may also have a **40-60** percent (more preferably, **45-55** percent) axial stiffness ratio of bead axial stiffness to combined bead-skin portion axial stiffness. Bead axial stiffness is the stiffness along the lengthwise direction of the bead stiffener **300**. The combined bead-skin axial stiffness is the bead axial stiffness combined with the in-plane stiffness of the skin panel portion **256** that is supported by the bead stiffener **300**. The in-plane stiffness of the skin panel portion **256** is measured parallel to the lengthwise direction of the bead stiffener **300**. Axial stiffness is a measure of the resistance of a structural member to in-plane deformation when subjected to an axial load. Axial loading of the bead stiffeners **300** and skin panels **250**, **252** may occur in response to chordwise bending due to the above-described aerodynamic loading of the skin panels **250**, **252**. For example, during upward deflection of an aileron **110**, the aerodynamic pressure on the upper surface of the aileron **110** induces chordwise bending of the aileron **110**, which may result in axial (i.e., in-plane) tension in the upper skin panel **250** and associated bead stiffeners **300**, and axial (i.e., in-plane) compression in the lower skin panel **252** and associated bead stiffeners **300**.

Referring to Figures **10-11**, shown in Figure **10** is a chordwise sectional view of an example of an aileron **110**. In the example shown, bead stiffeners **300** are coupled to the upper skin panel **250** and lower skin panel **252** via bonding and mechanical fasteners **450**. Also shown is the coupling of the upper and lower skin panels **250**, **252** to the front spar **202**. At the trailing edge portion **216** of the aileron **110**, the upper and lower skin panels **250**, **252** may be joined together via a trailing edge spacer **218** installed between the upper and lower skin panels **250**, **252**, as described in greater detail below.

Referring to Figure **11**, shown is an example of the front spar **202** formed in a single-piece configuration having a channel-shaped cross section including a spar web

206 and an opposing pair of spar outer flanges **208**. Each one of the spar outer flanges **208** is interconnected to the spar web **206** by a radius portion **212**. The spar web **206**, the radius portions **212**, and the spar outer flanges **208** are comprised of fabric plies **402**, with no unidirectional plies **404** in the spar web **206** or in the radius portions **212**.

5 The spar outer flanges **208** may include one or more **0-degree** plies **406** interleaved within the fabric plies **402** of the spar outer flanges **208**. The **0-degree** plies **406** are excluded from the radius portion **212** and the spar web **206** to avoid warpage (e.g., spring-in) of the spar outer flange toward the spar web during curing. The **0-degree** plies **406** may be located approximately mid-plane of the spar outer flange **208**, and may

10 increase the shear strength of the spar outer flanges **208** in the connection with the upper and lower skin panels **250**, **252**.

Referring to Figures **12-13**, shown is an example of the front spar **202** in a multi-piece configuration. Figures **12** and **13** respectively show the multi-piece configuration of the front spar **202** in an assembled state (Figure **12**) and a disassembled state

15 (Figure **13**). The front spar **202** has a pair of spar chords **214** (upper and lower) interconnected by a spar web **206**. Each of the spar chords **214** may include a spar inner flange **210** and a spar outer flange **208** interconnected by a radius portion **212**. The spar inner flange **210** of each spar chord **214** may be coupled to the spar web **206** via mechanical fastening, such as via a single or double row of mechanical fasteners

20 **450** extended through the spar inner flange **210** and the spar web **206**. The spar outer flange **208** of each spar chord **214** may be coupled to a skin panel (e.g., the upper skin panel **250** or the lower skin panel **252**). The spar outer flanges **208** may be bonded (e.g., co-bonded) to one of the skin panels **250**, **252**, and may additionally be

25 mechanically fastened via a single or double row of mechanical fasteners **450** that may be extended through the spar outer flange **208** and the skin panel. Each of the spar chords **214** is comprised of fabric plies **402**. The spar web **206** may be comprised of unidirectional plies **404**.

In some examples of the front spar **202**, the spar outer flanges **208** of the spar chords **214** in Figures **12-13** may optionally include one or more **0-degree** plies **406** for

increasing the shear strength of the spar outer flanges **208**, similar to the **0**-degree plies **406** in the front spar **202** of Figures **10-11**. The multi-piece configuration of the front spar **202** may simplify manufacturing of the movable surface **200** by allowing the spar outer flange **208** of each of the spar chords **214** to be bonded (e.g., co-bonded or secondary bonded) respectively to the upper and lower skin panels **250**, **252**, after which the upper and lower skin panels **250**, **252** and spar chords **214** may be coupled to the plurality of ribs **230**. The spar chords **214** (upper and lower) may be interconnected by fastening the spar web **206** to the spar inner flanges **210** of the spar chords **214**. Although Figures **12-13** show the spar web **206** mounted to the back side of the front spar **202**, in an example not shown, the spar web **206** on the opposite or front side of the front spar **202**.

Referring to Figure **14**, shown is an example of an arrangement of the trailing edge portion **216** of the movable surface **200**. In the example shown, the movable surface **200** includes the above-mentioned trailing edge spacer **218** positioned between the upper skin panel **250** and the lower skin panel **252**. The trailing edge spacer **218** may extend in a spanwise direction between the closeout ribs **232**. The trailing edge spacer **218** may be provided in a triangular shaped cross-sectional shape complementary to the angle between the inner surfaces of the upper and lower skin panels **250**, **252** at the trailing edge portion **216**. The trailing edge spacer **218** may be formed as a laminate of unidirectional plies **404** that, once cured, may be machined into the above-mentioned triangular shape. The upper and lower skin panels **250**, **252** may be bonded and/or mechanically fastened to the trailing edge spacer **218**. The trailing edge spacer **218** may provide a simple, low-cost means for interconnecting the upper and lower skin panels **250**, **252** at the trailing edge portion **216**.

Referring to Figures **15-16**, shown is a further example of an arrangement of the trailing edge portion **216** having a rear spar **204** extending along a spanwise direction between the movable surface ends **240** (e.g., between the closeout ribs **232**). The rear spar **204** may include a pair of spar outer flanges **208** on upper and lower sides of the rear spar **204**. The spar outer flanges **208** may be spaced apart from each other and

oriented respectively parallel to the upper skin panel **250** and lower skin panel **252**. The spar outer flanges **208** may be interconnected by a spar web **206** which may be oriented non-parallel to the spar outer flanges **208**, although the rear spar **204** may have a different cross-sectional shape than the shape shown in Figures **15-16**. Although not shown in Figures **15-16**, the ribs **230** of the movable surface **200** may be attached to the rear spar **204**. In addition, the upper skin panel **250** and the lower skin panel **252** may each be coupled to the rear spar **204** such as by bonding and/or via mechanical fasteners **450** coupling the upper skin panel **250** and lower skin panel **252** to the spar outer flanges **208** respectively on the upper and lower sides of the rear spar **204**.

Referring still to Figures **15-16**, the movable surface **200** may include a trailing edge wedge **220** configured to be removably coupled to the rear spar **204**. The trailing edge wedge **220** may extend along a spanwise direction and may have a length equal to the length of the rear spar **204**. The trailing edge wedge **220** may be formed of composite material such as fabric plies **402**, and may have a cross-sectional shape defined by a wedge upper flange **222** and a wedge lower flange **224** oriented at an acute angle relative to each other. The wedge upper flange **222** and the wedge lower flange **224** may be parallel respectively to the upper skin panel **250** and the lower skin panel **252**. When the trailing edge wedge **220** is attached to the rear spar **204**, the outer surface of the web upper flange and wedge lower flange **224** may be flush (e.g., no steps) with the outer surface respectively of the upper skin panel **250** and lower skin panel **252** to provide an aerodynamically smooth surface for airflow.

The wedge upper flange **222** and the wedge lower flange **224** may be attached to the spar outer flanges **208** respectively on the upper and lower sides of the rear spar **204**. For example, the trailing edge wedge **220** may be coupled to the rear spar **204** by means of mechanical fasteners **450** (e.g., screws, bolts, other threaded fasteners) installed in fastener holes formed in the wedge upper and lower flanges **222**, **224** and the spar outer flanges **208**. Mechanical fasteners **450** may be threadably engaged to threaded receptacles (not shown) such as nut plates or threaded inserts permanently mounted to or installed in the rear spar **204**. By configuring the trailing edge wedge **220**

to be easily removable from the rear spar **204**, any damage to the trailing edge portion **216** of the movable surface **200** may be addressed by simply removing and replacing the trailing edge wedge **220**. In this regard, the trailing edge wedge **220** avoids one of the drawbacks associated with conventional movable surfaces, which require removal
5 of the entire movable surface if the trailing edge is damaged, and replacement with a new movable surface.

Referring now to Figure **17**, shown is a method **500** of manufacturing a movable surface **200** (e.g., a flight control surface) of an aircraft **100**. As mentioned above, in some examples, the movable surface **200** may be manufactured as an aileron **110** as
10 shown in the figures. Alternatively, the movable surface **200** may be manufactured as an elevator **122**, a rudder **118**, a flap **112**, or any one of a variety of other types of movable surfaces **200**.

The method **500** may include manufacturing a front spar **202** by laying up a plurality of fabric plies **402** to result in the front spar **202** having a channel-shaped. The
15 front spar **202** may have a single-piece configuration having a spar web **206** and an opposing pair of spar outer flanges **208** each interconnected to the spar web **206** by a radius portion **212**. To improve the shear capability of the spar outer flanges **208**, the method **500** may include interleaving one or more **0-degree** plies **406** within the fabric plies **402** of the spar outer flanges **208**. The one or more **0-degree** plies **406** may be
20 interleaved at an approximate mid-plane of each spar outer flange **208**, and may be excluded from the radius portion **212**.

In some examples, the front spar **202** may be manufactured in a multi-piece configuration, which may include laying up a spar web **206**, and separately laying up pair of spar chord **214** each having a spar outer flange **208** and a spar inner flange **210**
25 interconnected by a radius portion **212**. The spar outer flange **208** may be oriented approximately **90 degrees** (± 30 degrees) to the spar inner flange **210**. The method **500** may include bonding the spar outer flange **208** of the spar chords **214** respectively to the upper skin panel **250** or the lower skin panel **252** as mentioned above, after which the upper and lower skin panels **250**, **252** may be coupled to the ribs **230** (described

below), and the spar web **206** may be fastened to the spar inner flanges **210** to interconnect the spar chords **214**.

5 The method **500** may also include mounting one or more attach fittings **124** to the front spar **202**. The attach fittings **124** may be comprised of metallic material (e.g., aluminum or titanium) or composite material (e.g., graphite-epoxy), and may be mounted to the front spar **202** at locations that are aligned with the ribs **230**. As mentioned above, the attach fittings **124** may couple the movable surface **200** (e.g., an aileron) to an aerodynamic member **102** (e.g., a wing).

10 The method **500** may additionally include laying up a plurality of fabric plies **402** to result in a plurality of ribs **230**. The ribs **230** may each be laid up in a channel-shaped cross section having a rib web **238** and an opposing pair of rib flanges **236** in a single-piece configuration. Similar to the above-described front spar **202**, each rib flange **236** may be interconnected to the rib web **238** by a radius portion **212**. The method may further include interleaving one or more **0-degree** plies **406** within the fabric plies **402** of the rib flanges **236** to improve the shear capability of the rib flanges **236**. The **0-degree** plies **406** may be interleaved at an approximate mid-plane of each rib flange **236**. The **0-degree** plies **406** may be excluded from the radius portion **212** and the rib web **238**.

15 The method **500** includes step **502** of coupling the ribs **230** to the front spar **202** of the movable surface **200**. As mentioned above, the front spar **202** extends along a spanwise direction between the opposing movable surface ends **240** of the movable surface **200**. Each rib **230** extends between the front spar **202** and a trailing edge portion **216** of the movable surface **200**. Each rib **230** may be oriented along a chordwise direction or a streamwise direction of the movable surface **200**. The ribs **230** include a closeout rib **232** at each of the movable surface ends **240**, and a plurality of intermediate ribs **234** located at spaced intervals between the closeout ribs **232**. The ribs **230** may be located on the front spar **202** at spaced intervals between the movable surface ends **240**. A plurality of bays **242** may be defined between adjacent pairs of the ribs **230**.

The method **500** may additionally include laying up a plurality of fabric plies **402** to result in a plurality of bead stiffeners **300**. Each bead stiffener **300** may be devoid of unidirectional plies **404**, which may avoid undesirable warpage and/or wrinkling that may otherwise occur in the bead stiffeners **300**. As described above, each bead stiffener **300** may be laid up such that the bead stiffener **300** has a bead stiffener cap **304** having a rounded cross-sectional shape, and such that the cap ends **306** are closed. The rounded cross-sectional shape may be a semi-circular cross-sectional shape, a semi-elliptical cross-sectional shape, a semi-oval cross-sectional shape, or other cross-sectional shape.

The laying up the bead stiffeners **300** may include laying up the bead stiffeners **300** have a bead stiffener cap **304** having a cross section that is constant along a lengthwise direction of the bead stiffener **300**. In this regard, a shipset of bead stiffeners **300** for a movable surface **200** may be laid up to have a common configuration. For example, each bead stiffener **300** within a shipset may have the same cross-sectional size, same cross-sectional shape, same ply composition, same ply quantity, and same ply stacking sequence, which may significantly reduce the cost and time required for manufacturing a movable surface **200**. For movable surfaces **200** having a tapering width such as the aileron **110** shown in the figures, the bead stiffeners **300** may be manufactured with different lengths corresponding to the width of the movable surface **200** at each of the mounting locations of the bead stiffeners **300**.

The bead stiffeners **300** may be laid up to have a bead bending stiffness that is approximately **40-60** percent of the combined bead-skin portion bending stiffness of the bead stiffener **300** and the skin panel portion **256** (i.e., of the upper skin panel **250** or lower skin panel **252**) supported by the bead stiffener **300**, as described above. More preferably, the bead stiffeners **300** may be laid up to have a bead bending stiffness that is approximately **45-55** percent of the combined bead-skin portion bending stiffness. In addition to the above-mentioned bending stiffness ratio, the bead stiffeners **300** may also be laid up to have a **40-60** percent (more preferably, **45-55** percent) axial stiffness ratio of bead axial stiffness to combined bead-skin portion axial stiffness. As described

above, configuring each bead stiffener **300** to have a bead stiffness (i.e., bending stiffness and/or axial stiffness) that is lower than the combined bead-skin portion stiffness (i.e., bending stiffness and/or axial stiffness) of the skin panel portion **256** and the bead stiffener **300** may avoid high peel stress in the bondline between the bead stiffener flanges **302** and the inner surface of the skin panels **250**, **252**, and which may otherwise result in separation of the bead stiffener **300** from the skin panel portion **256**.

In some examples, the bead stiffeners **300** may be laid up over a foam member **312**. As mentioned above, the foam member **312** may be comprised of closed-cell foam, although other materials may be used. The foam member **312** may be contoured complementary to a final shape of the bead stiffener **300**, and may serve as a layup mandrel and/or a curing mandrel for the bead stiffener **300**. Each bead stiffener **300** may be separately laid up over a foam member **312**, and then co-cured with an upper or lower skin panel **250**, **252** in a single cure cycle. In another example, each of the bead stiffeners **300** may be laid up over a foam member **312**, and then co-bonded in the uncured state (e.g., green state) to a cured skin panel (e.g., upper or lower skin panel **250**, **252**). In a still further example, the bead stiffeners **300** in the cured state may be co-bonded to a skin panel **250**, **252** in the uncured state. Even further, bead stiffeners **300** in the cured state may be secondary bonded to a skin panel **250**, **252** in the cured state using an adhesive layer between the bead stiffener flanges **302** and the skin panel **250**, **252**.

The method **500** may optionally include removing the foam member **312** from each bead stiffener **300** after curing of the bead stiffener **300**. However, in other examples, the foam member **312** may be retained within the bead stiffeners **300** after curing, and may remain within the bead stiffener cavity **310** during the life of the movable surface **200**. In such an arrangement where the foam member **312** remains within the bead stiffener cavity **310**, the foam member **312** may increase the bending stiffness of the bead stiffeners **300**. Regardless of whether or not the foam member **312** is retained within the bead stiffener cavity **310**, the bead stiffeners **300** may be coupled to the skin

panels **250, 252** via bonding (e.g., co-curing, co-bonding, or secondary bonding) and/or via mechanical fastening of the bead stiffener flanges **302** to the skin panels **250, 252**.

The method **500** may include laying up a plurality of unidirectional plies **404** to result in the upper skin panel **250** and/or the lower skin panel **252**. As mentioned above, each skin panel **250, 252** may advantageously be laid up without ply drops (not shown), and which may result in the skin panels **250, 252** each having a panel thickness **254** that is constant in the chordwise direction, and constant in the spanwise direction, as described above. Fabric plies **402** may be omitted from the skin panels **250, 252** to avoid potential warpage and/or wrinkling of the skin panels **250, 252** during curing.

Step **504** of the method **500** includes coupling a plurality of bead stiffeners **300** to an inner surface of at least one of an upper skin panel **250** and a lower skin panel **252**, as mentioned above. The method **500** may include locating one or more bead stiffeners **300** within one or more of the bays **242** of the movable surface **200**. More preferably, two or more bead stiffeners **300** may be coupled to each of the upper and lower skin panels **250, 252** within each bay **242** of the movable surface **200**. The bead stiffeners **300** may be oriented parallel or generally parallel to each other, and are non-parallel to the front spar **202**. Each bead stiffeners **300** may be located such that the opposing cap ends **306** are located in close proximity to, but are non-contacting, respectively the front spar **202** and the trailing edge portion **216**.

The step **504** of coupling the bead stiffeners **300** to the upper or lower skin panel **250, 252** may include spacing the bead stiffeners **300** apart from each other at a spanwise spacing **316** of from **6-11** inches between bead centerlines **314**. More preferably, the spanwise spacing **316** may be between **7.5 to 9.5** inches. However, as indicated above, the spanwise spacing **316** may be dictated by the stiffness requirements of the skin panel, which may be dictated by the predicted maximum load (i.e., limit load) on the movable surface **200** during flight. For example, the bending stiffness of a structural member is a function of the second moment of inertia of the structural member, which is a function of cross-sectional area. As noted above, the

cross-sectional area of a skin panel portion **256** may be a function of (i.e., the product of) the panel portion width **264** and the panel thickness **254**.

Step **506** of the method **500** includes coupling the upper skin panel **250** and the lower skin panel **252** to the plurality of ribs **230** and to the front spar **202**. For examples of the movable surface **200** having a trailing edge spacer **218**, the method may include laying up the trailing edge spacer **218** in a triangular shape that is complementary to the orientations of the upper skin panel **250** and lower skin panel **252**. The method may include laying unidirectional plies **404** to result in the trailing edge spacer **218**, after which the trailing edge spacer **218** may be cured and machined into a triangular shape that is complementary to the angle defined between the upper and lower skin panel **250**, **252**. The upper skin panel **250** and lower skin panel **252** may be coupled to the trailing edge spacer **218** via bonding and/or mechanical fasteners **450**.

As an alternative to a trailing edge spacer **218**, the method **500** may include laying up a rear spar **204**. The rear spar **204** may be laid up of fabric plies **402** similar to the above-described operation for laying up the front spar **202**. The rear spar **204** may include spar outer flanges **208** on the upper and lower sides of the rear spar **204**. The spar outer flanges **208** may be interconnected by a spar web **206**. The method **500** may include coupling the upper skin panel **250** and the lower skin panel **252** to the forward portions of the spar outer flanges **208** of the rear spar **204**. The method **500** may further include removably attaching a trailing edge wedge **220** to the rear spar **204**. More specifically, the wedge upper flange **222** and wedge lower flange **224** of the trailing edge wedge **220** may be respectively coupled to the spar outer flanges **208** on the upper and lower sides of the rear spar **204**. The trailing edge wedge **220** may be coupled to the rear spar **204** via mechanical fasteners **450**. The fasteners **450** may include threaded fasteners or non-threaded fasteners. Examples of threaded fasteners include screws, bolts, or other types of threaded fasteners allowing for field removal and/or replacement of the trailing edge wedge **220**.

Referring now to Figure **18**, shown is a flowchart of a method **600** of loading (i.e., applying a load to) a movable surface **200** of an aircraft **100**. The method includes step

602 of providing the movable surface **200** which, as described above, includes a front spar **202** extending between opposing movable surface ends **240**. In addition, the movable surface **200** includes a plurality of ribs **230** located at spaced intervals between the movable surface ends **240** and which define a plurality of bays **242** between adjacent pairs of the ribs **230**. Each rib **230** extends between the front spar **202** and a trailing edge portion **216** of the movable surface **200**. The movable surface **200** further includes an upper skin panel **250** and a lower skin panel **252** each coupled to the plurality of ribs **230** and the front spar **202**. Furthermore, the movable surface **200** includes a plurality of bead stiffeners **300** coupled to an inner surface of the upper skin panel **250** and/or the lower skin panel **252**. The bead stiffeners **300** within one or more of the bays **242** are spaced apart from each other and are oriented non-parallel to the front spar **202** and have a bead stiffener cap **304** having opposing cap ends **306** respectively located proximate the front spar **202** and the trailing edge portion **216**.

Step **604** of the method **600** includes placing the movable surface **200** in a non-loaded condition. The non-loaded condition may be associated with the aircraft **100** being substantially non-moving (e.g., parked at a gate of an airport) and/or under a ground static loading in which the movable surface **200** is subjected to gravitational force due to the structural mass of the movable surface **200**. The method **600** additionally includes step **606** of placing the movable surface **200** in a loaded condition wherein the aircraft **100** is in motion and the movable surface **200** is subjected to one or more dynamic loads. For example, the aircraft **100** in motion may subject the movable surface **200** to gravitational force and inertial forces due to the structural mass of the movable surface **200**. Other examples of dynamic loads include aerodynamic loads on the movable surface **200** when the aircraft **100** is in flight, and/or loads on the movable surface **200** as a result of in-flight deflection of the movable surface **200** such as during deflection of an aileron **110** for roll control, deflection of a rudder **118** for yaw control, and/or deflection of an elevator **122** for pitch control of the aircraft **100**.

The method **600** may additionally include removing and replacing the trailing edge wedge **220** from the movable surface **200**. Advantageously, the trailing edge wedge **220**

may be removably attached to the rear spar **204** by removing the mechanical fasteners **450** attaching the trailing edge wedge **220** to the rear spar **204**. As mentioned above, the fasteners **450** may include threaded fasteners or non-threaded fasteners. Examples of threaded fasteners include screws, bolts, or other types of threaded fasteners which
5 may be readily accessible for field removal of the trailing edge wedge **220** for repair and/or replacement.

Additional modifications and improvements of the present disclosure may be apparent to those of ordinary skill in the art. Thus, the particular combination of parts described and illustrated herein is intended to represent only certain embodiments of
10 the present disclosure and is not intended to serve as limitations of alternative embodiments or devices within the spirit and scope of the disclosure.

EMBODIMENTS IN WHICH AN EXCLUSIVE PROPERTY OR PRIVILEGE IS CLAIMED ARE DEFINED AS FOLLOWS:

1. A movable surface of an aircraft, comprising:

5

a front spar extending along a spanwise direction between opposing movable surface ends;

10

a plurality of ribs located at spaced intervals between the movable surface ends and defining a plurality of bays between adjacent pairs of the ribs, each rib extending between the front spar and a trailing edge portion of the movable surface;

15

an upper skin panel and a lower skin panel coupled to the plurality of ribs and the front spar; and

20

a plurality of bead stiffeners coupled to an inner surface of at least one of the upper skin panel and the lower skin panel, the bead stiffeners within the bays being spaced apart from each other and oriented non-parallel to the front spar and having a bead stiffener cap having opposing cap ends respectively locate proximate the front spar and the trailing edge portion.

2. The movable surface of Claim 1, further comprising:

25

a rear spar located proximate the trailing edge portion and extending between opposing movable surface ends;

at least some of the plurality of ribs extending between the front spar and the rear spar;

the upper skin panel and the lower skin panel coupled to the plurality of ribs, the front spar, and the rear spar; and

5 the opposing cap ends of each of the bead stiffeners respectively located proximate the front spar and the rear spar.

3. The movable surface of Claim 2, further comprising:

10 a trailing edge wedge removably attachable to the rear spar and extending along the spanwise direction of the rear spar.

4. The movable surface of any one of Claims 1 to 3, wherein:

15 at least one of the upper skin panel and the lower skin panel has a panel thickness that is constant along the spanwise direction between the movable surface ends.

5. The movable surface of any one of Claims 1 to 4, wherein:

20 the bead stiffener cap of at least some of the bead stiffeners has a rounded cross-sectional shape.

6. The movable surface of any one of Claims 1 to 5, wherein:

25 each bead stiffener has a bead bending stiffness that is approximately **40-60** percent of a combined bead-skin portion bending stiffness of the bead stiffener and a skin panel portion of the upper skin panel or lower skin panel supported by the bead stiffener; and

the skin panel portion having a panel portion width defined as one of the following:

5 the panel portion width extending between midpoints respectively located on opposite sides of the bead stiffener, each midpoint located midway between the bead stiffener and an immediately adjacent bead stiffener;

10 the panel portion width extending between a rib on one side of the bead stiffener and, on an opposite side of the bead stiffener, a midpoint between the bead stiffener and an immediately adjacent bead stiffener.

15 **7.** The movable surface of any one of Claims **1** to **6**, wherein:

 one or more of the ribs has a channel-shaped cross section having a rib web and an opposing pair of rib flanges;

20 the rib web and the rib flanges are comprised of fabric plies; and

 the rib flange of at least one of the ribs having one or more **0**-degree plies.

8. The movable surface of any one of Claims **1** to **7**, wherein:

25 the front spar has a channel-shaped cross section having a spar web and an opposing pair of spar outer flanges;

 the spar web and the spar outer flanges are comprised of fabric plies; and

the spar outer flange having one or more 0-degree plies.

9. The movable surface of any one of Claims 1 to 8, wherein:

5

the movable surface is an aileron.

10. A method of manufacturing a movable surface of an aircraft, comprising:

10

coupling a plurality of ribs to a front spar of a movable surface, each rib extending between the front spar and a trailing edge portion of the movable surface, the front spar extending along a spanwise direction between opposing movable surface ends of the movable surface, the ribs being located at spaced intervals between the movable surface ends and defining a plurality of bays between adjacent pairs of the ribs;

15

coupling a plurality of bead stiffeners to an inner surface of at least one of an upper skin panel and a lower skin panel of the movable surface, the bead stiffeners within the bays being spaced apart from each other at a spanwise spacing and having a bead stiffener cap having opposing cap ends respectively located proximate the front spar and the trailing edge portion; and

20

coupling the upper skin panel and the lower skin panel to the plurality of ribs and to the front spar.

25

11. The method of Claim 10, further comprising:

coupling the upper skin panel and the lower skin panel to a rear spar located proximate the trailing edge portion and extending along a spanwise direction between the movable surface ends.

5 **12.** The method of Claim **11**, further comprising:

removably coupling a trailing edge wedge to the rear spar, the trailing edge wedge extending along the spanwise direction of the rear spar and defining the trailing edge portion.

10

13. The method of any one of Claims **10** to **12**, wherein:

laying up a plurality of unidirectional plies to result in at least one of the upper skin panel and the lower skin panel having a panel thickness that is constant.

15

14. The method of any one of Claims **10** to **13**, wherein:

laying up a plurality of fabric plies to result in the bead stiffeners each having a bead stiffener cap having a rounded cross sectional shape.

20

15. The method of any one of Claims **10** to **14**, wherein:

laying up a plurality of fabric plies to result in the ribs having a channel-shaped cross section having a rib web and an opposing pair of rib flanges; and

25

interleaving one or more **0**-degree plies within the fabric plies of the rib flanges.

16. The method of any one of Claims 10 to 15, further comprising:

5 laying up a plurality of fabric plies to result in the front spar having a channel-shaped cross section having a spar web and an opposing pair of spar outer flanges; and

interleaving one or more 0-degree plies within the fabric plies of the spar outer flanges.

10

17. The method of any one of Claims 10 to 16, wherein:

the movable surface is an aileron.

15 18. A method of loading a movable surface of an aircraft, comprising:

providing a movable surface, including:

20 a front spar extending between opposing movable surface ends;

a plurality of ribs located at spaced intervals between the movable surface ends and defining a plurality of bays between adjacent pairs of the ribs, each rib extending between the front spar and a trailing edge portion of the movable surface and oriented generally parallel to a chordwise direction of the movable surface;

25

an upper skin panel and a lower skin panel coupled to the plurality of ribs and the front spar;

5 a plurality of bead stiffeners coupled to an inner surface of at least one of the upper skin panel and the lower skin panel within one or more of the bays, the bead stiffeners within the bays being spaced apart from each other and having a bead stiffener cap having opposing cap ends respectively located proximate the front spar and the trailing edge portion;

placing the movable surface in a non-loaded condition; and

10 placing the movable surface in a loaded condition.

19. The method of Claim 18, wherein:

15 the non-loaded condition is associated with the aircraft being substantially non-moving and under a ground static loading in which the movable surface is subjected to gravitational force due to a structural mass of the movable surface; and

20 the loaded condition is associated with the aircraft in motion in which the movable surface is subjected to at least one of:

gravitational force and inertial force due to the structural mass of the movable surface; and

25 aerodynamic loads on the movable surface.

20. The method of Claim 18 or Claim 19, further comprising:

removing and replacing a trailing edge wedge attached to a rear spar of the movable surface.

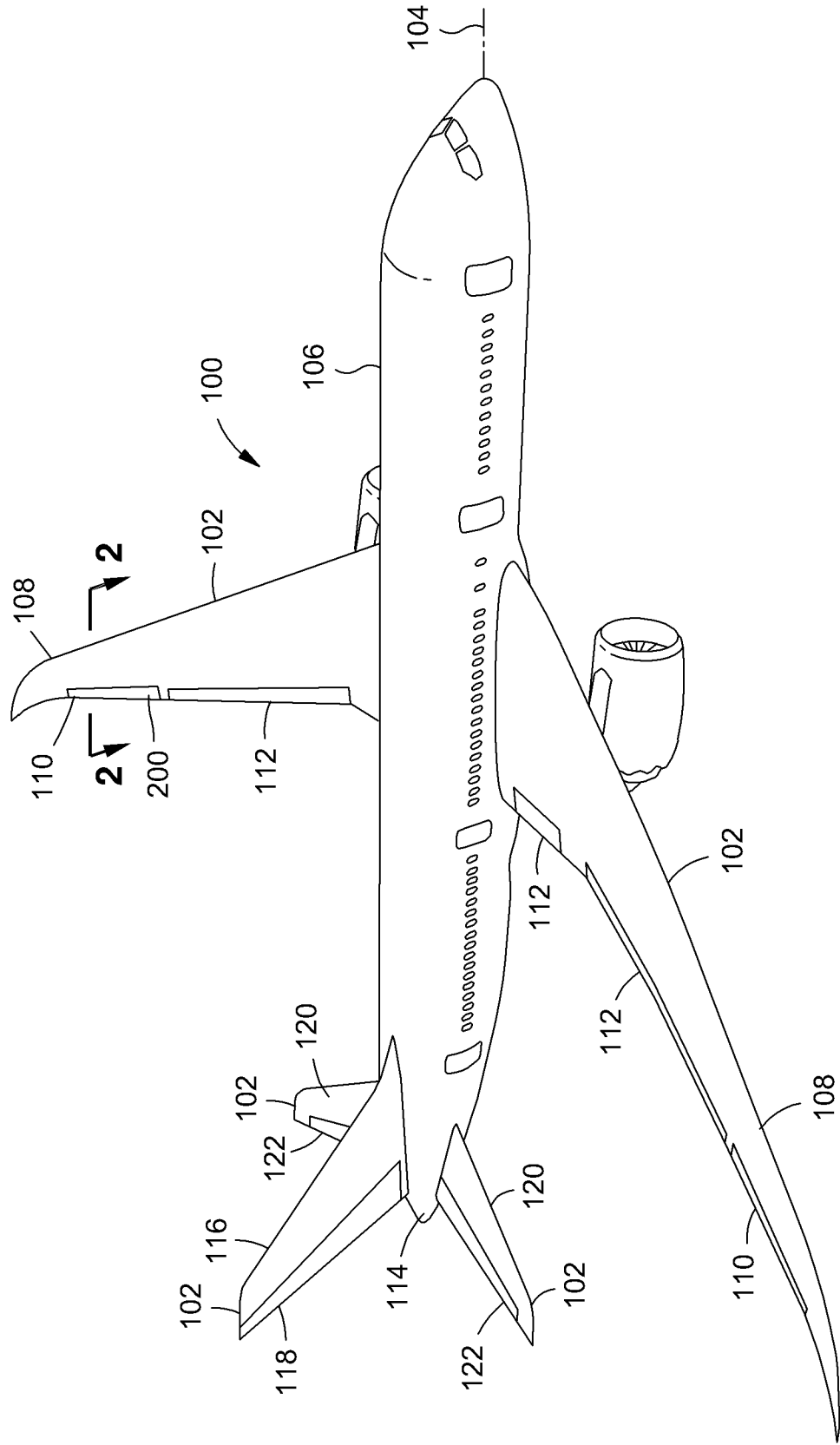

FIG. 1

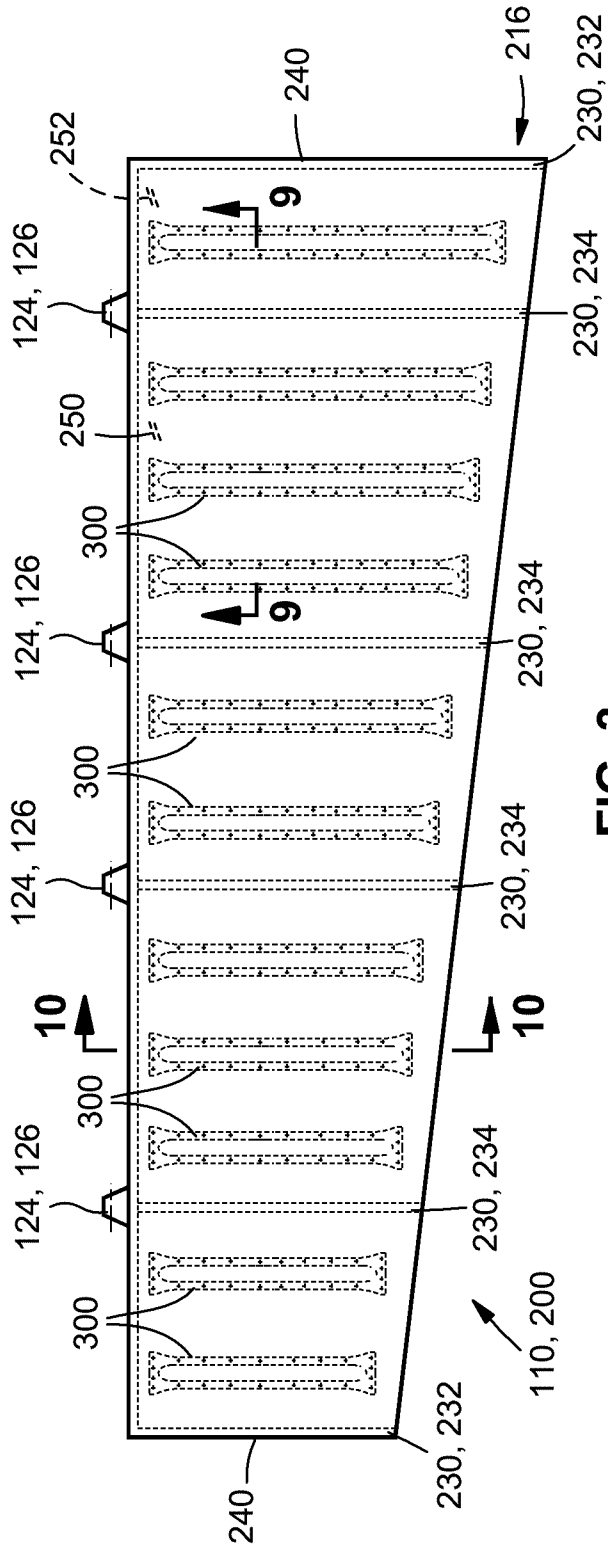

FIG. 3

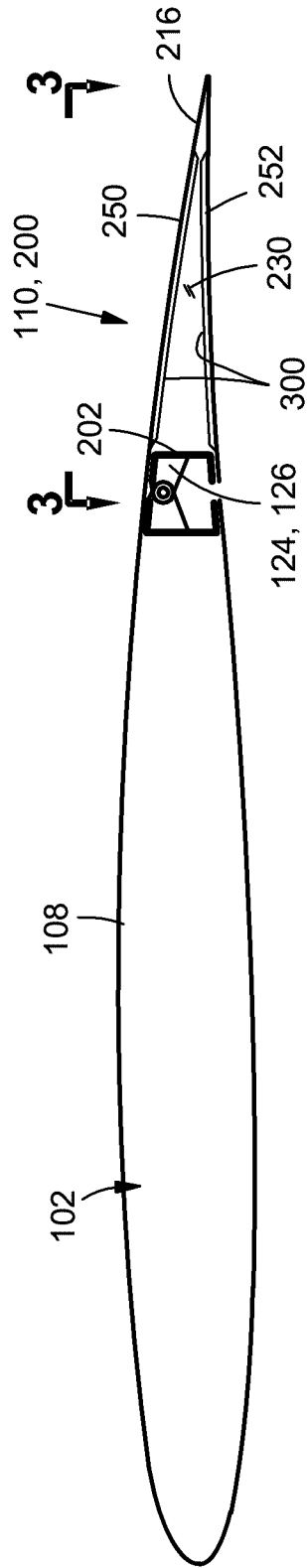

FIG. 2

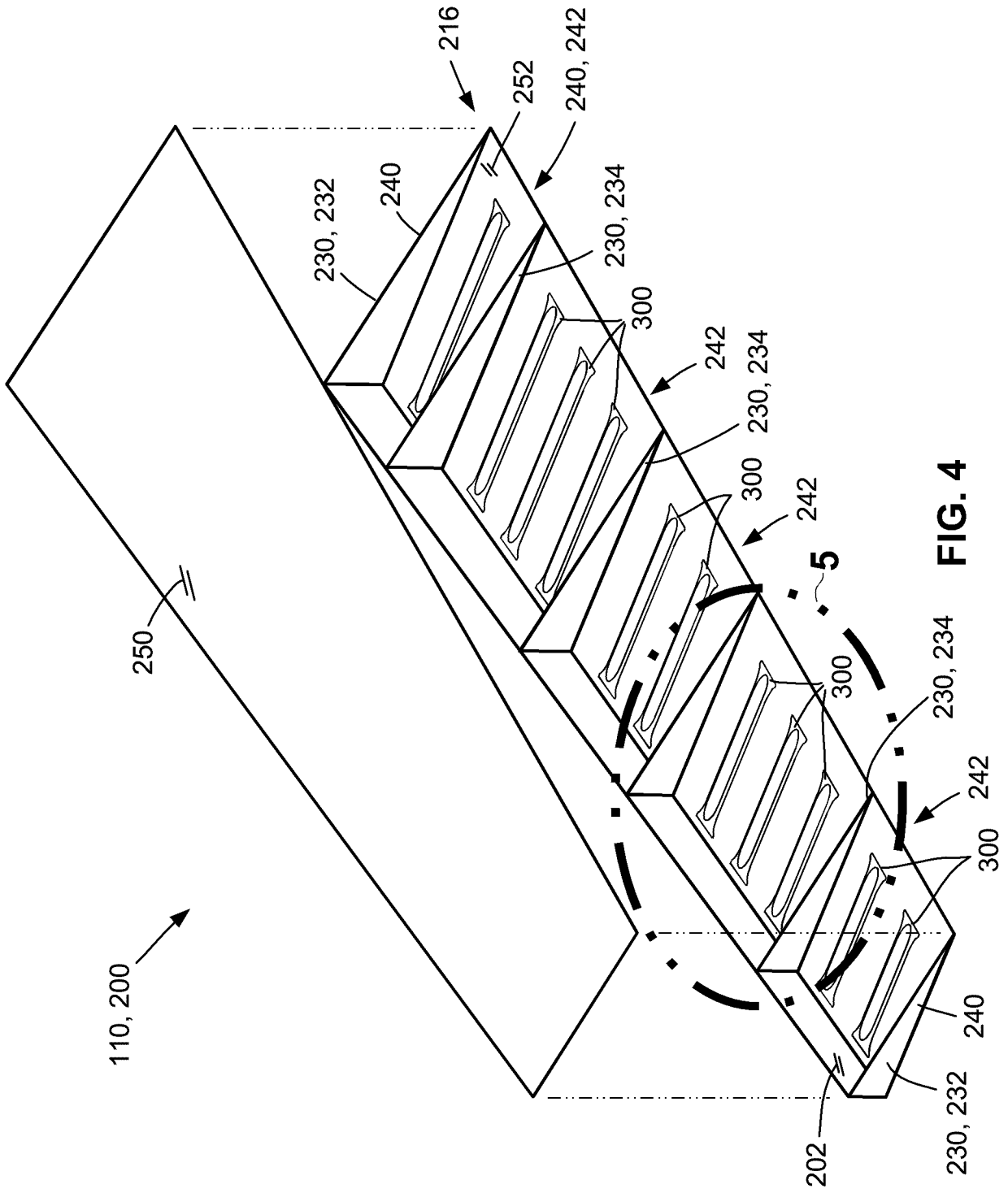

FIG. 4

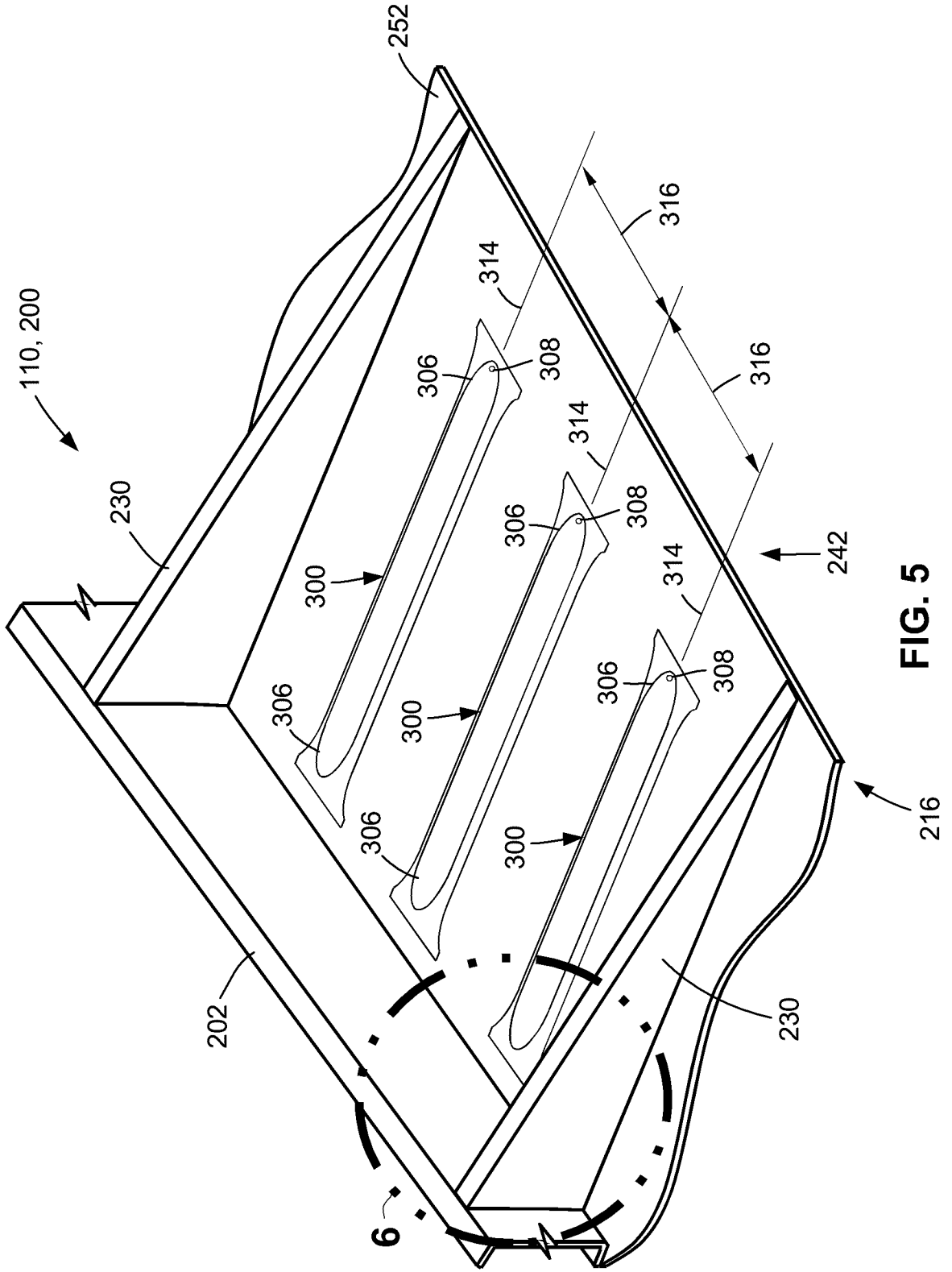

FIG. 5

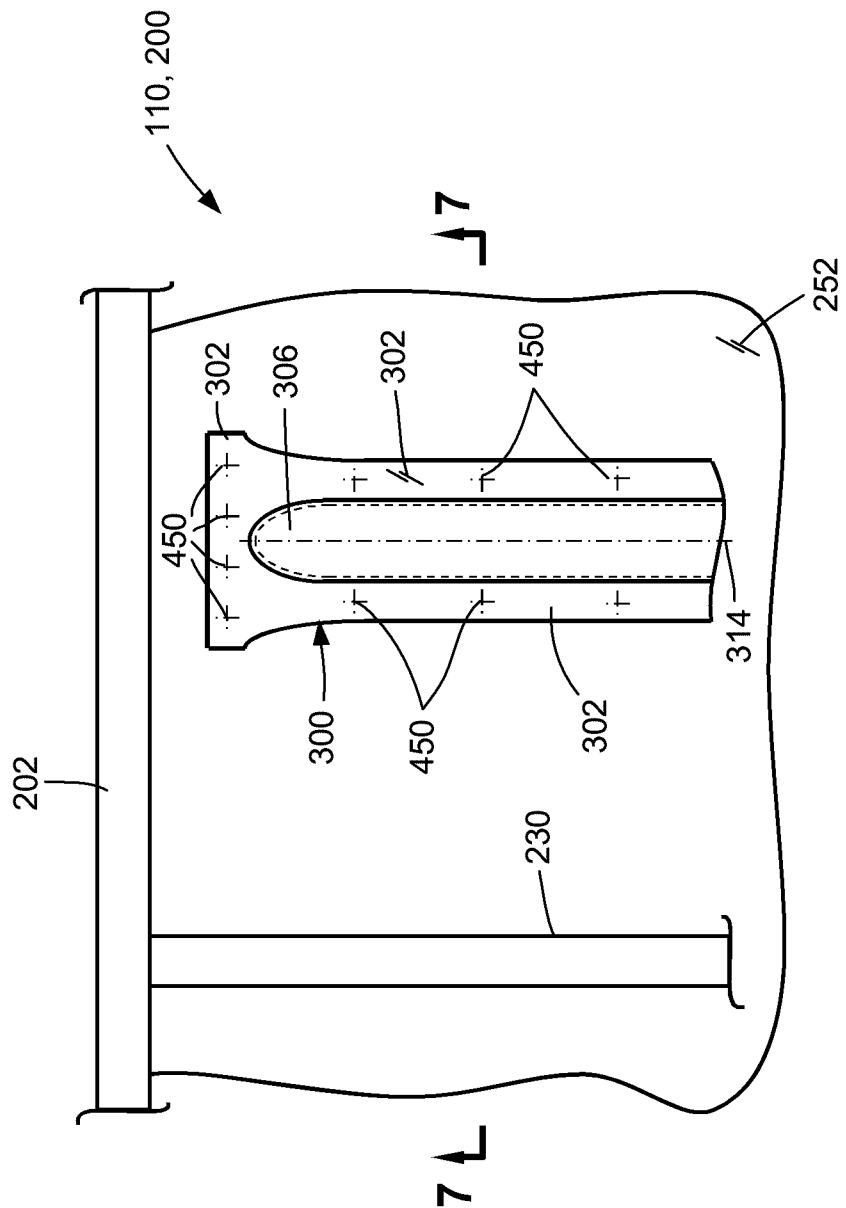

FIG. 6

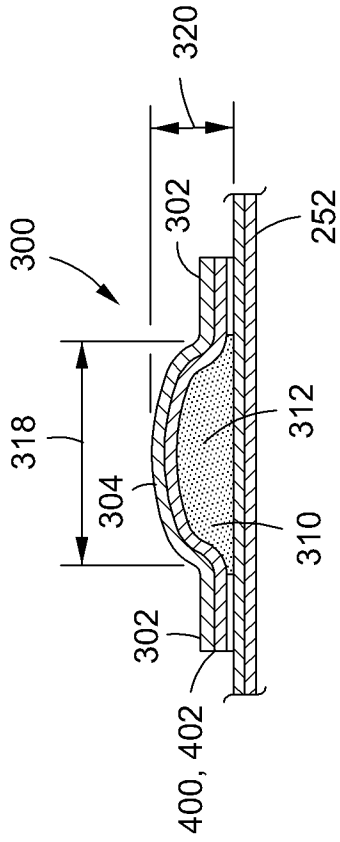

FIG. 8

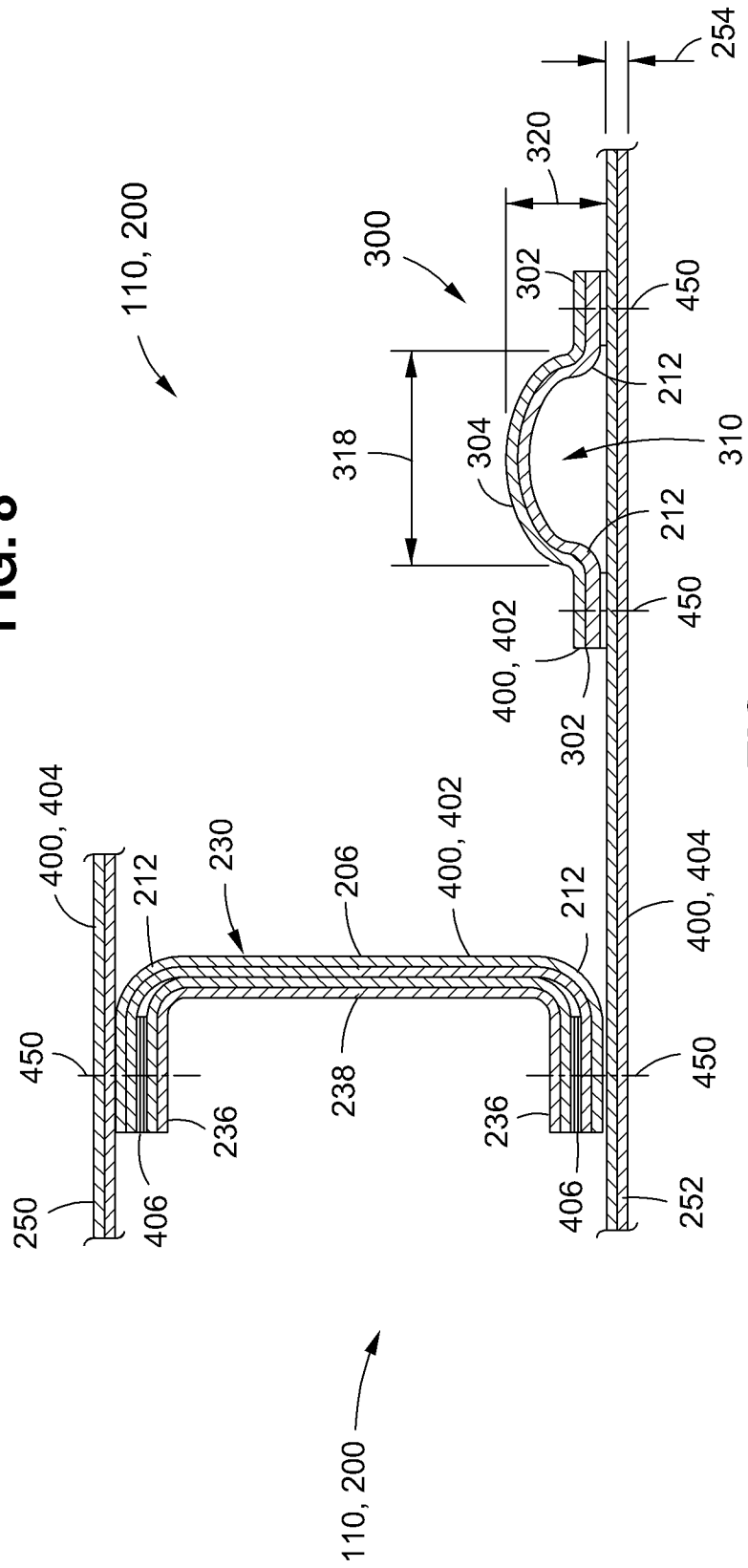

FIG. 7

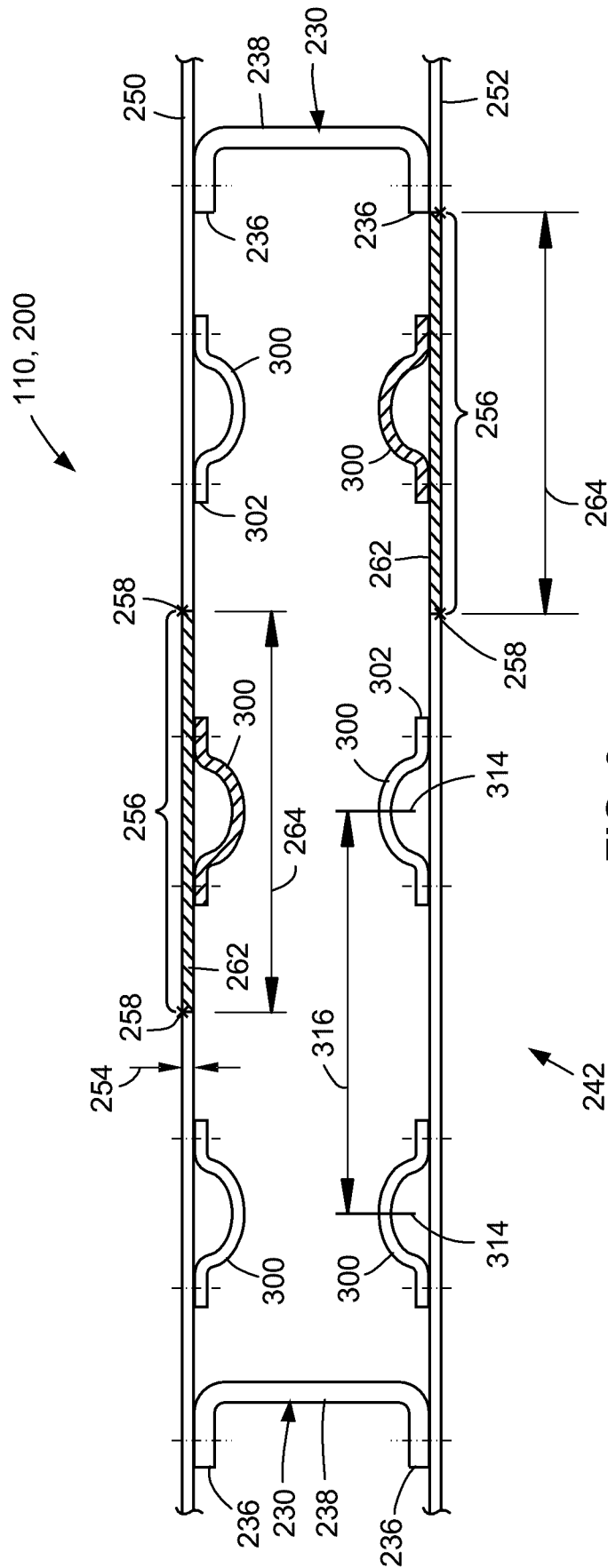

FIG. 9

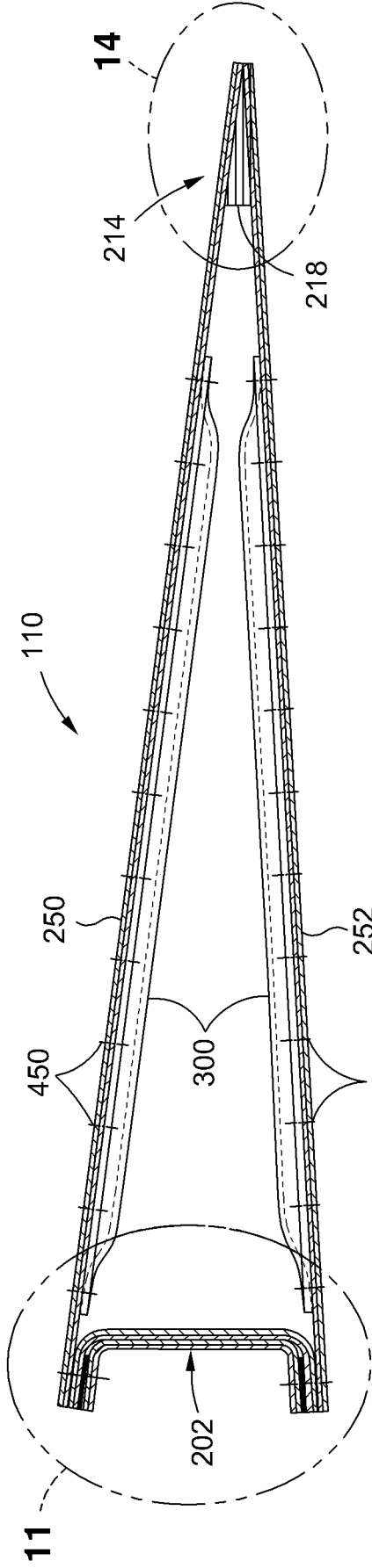

FIG. 10

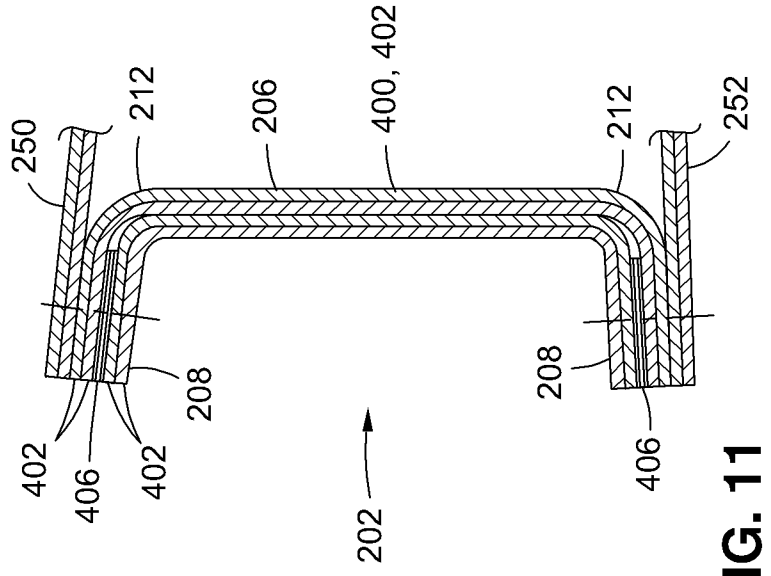

FIG. 11

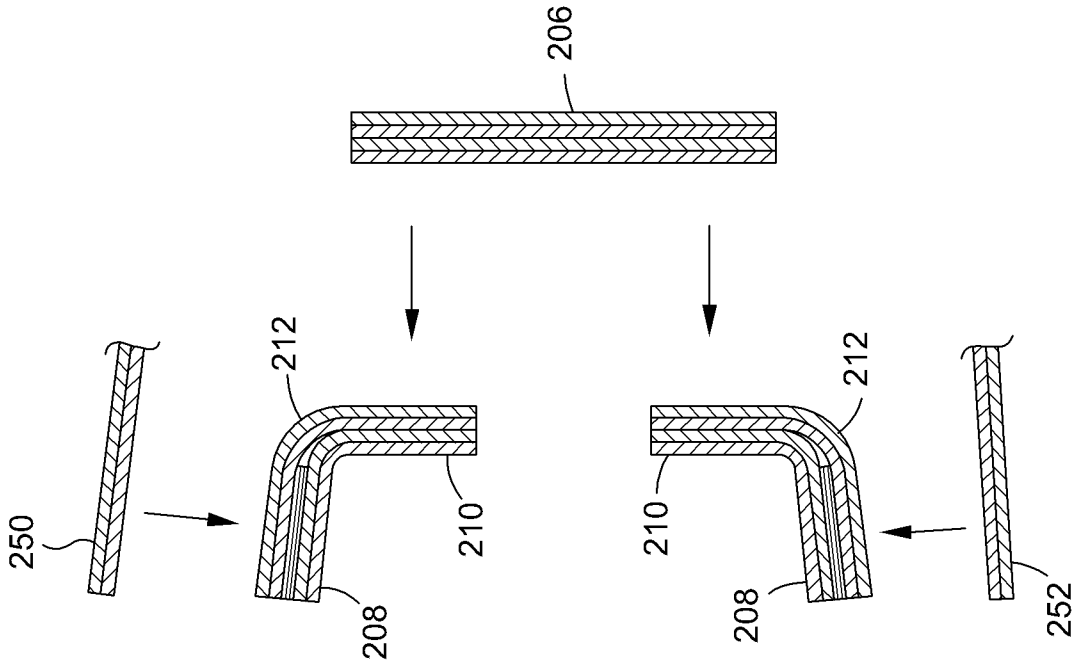

FIG. 13

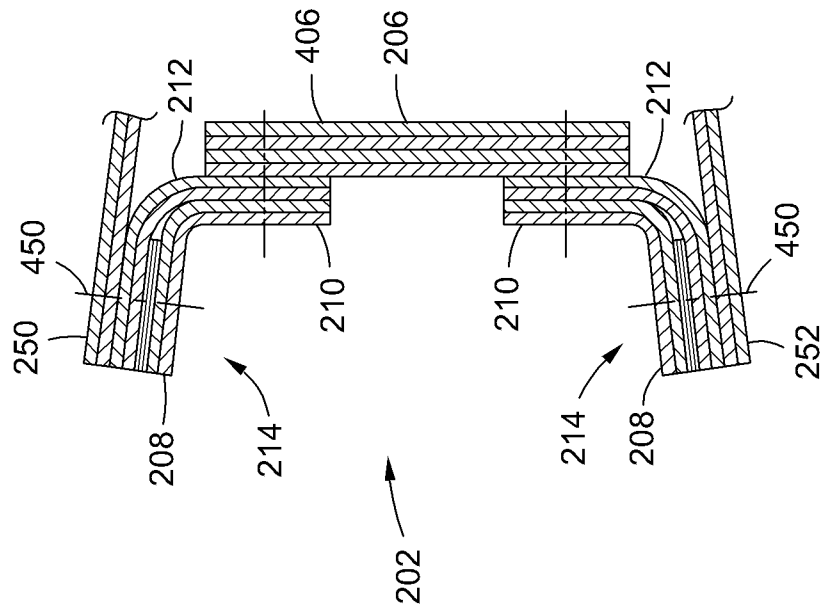

FIG. 12

500

COUPLING A PLURALITY OF RIBS TO A FRONT SPAR OF A MOVABLE SURFACE, EACH RIB EXTENDING BETWEEN THE FRONT SPAR AND A TRAILING EDGE PORTION OF THE MOVABLE SURFACE, THE FRONT SPAR EXTENDING ALONG A SPANWISE DIRECTION BETWEEN OPPOSING MOVABLE SURFACE ENDS OF THE MOVABLE SURFACE, THE RIBS BEING LOCATED AT SPACED INTERVALS BETWEEN THE MOVABLE SURFACE ENDS AND DEFINING A PLURALITY OF BAYS BETWEEN ADJACENT PAIRS OF THE RIBS

502



COUPLING A PLURALITY OF BEAD STIFFENERS TO AN INNER SURFACE OF AT LEAST ONE OF AN UPPER SKIN PANEL AND A LOWER SKIN PANEL OF THE MOVABLE SURFACE, THE BEAD STIFFENERS WITHIN ONE OR MORE OF THE BAYS BEING SPACED APART FROM EACH OTHER AT A SPANWISE SPACING AND ORIENTED ALONG A DIRECTION NON-PARALLEL TO THE FRONT SPAR AND HAVING A BEAD STIFFENER CAP HAVING OPPOSING CAP ENDS RESPECTIVELY LOCATED PROXIMATE THE FRONT SPAR AND THE TRAILING EDGE PORTION

504



COUPLING THE UPPER SKIN PANEL AND THE LOWER SKIN PANEL TO THE PLURALITY OF RIBS AND TO THE FRONT SPAR

506

FIG. 17

600

PROVIDING A MOVABLE SURFACE, INCLUDING:

A FRONT SPAR EXTENDING BETWEEN OPPOSING MOVABLE SURFACE ENDS;
A PLURALITY OF RIBS LOCATED AT SPACED INTERVALS BETWEEN THE
MOVABLE SURFACE ENDS AND DEFINING A PLURALITY OF BAYS BETWEEN
ADJACENT PAIRS OF THE RIBS, EACH RIB EXTENDING BETWEEN THE FRONT
SPAR AND A TRAILING EDGE PORTION OF THE MOVABLE SURFACE AND
ORIENTED GENERALLY PARALLEL TO A CHORDWISE DIRECTION OF THE
MOVABLE SURFACE;

AN UPPER SKIN PANEL AND A LOWER SKIN PANEL EACH COUPLED TO THE
PLURALITY OF RIBS AND THE FRONT SPAR;

A PLURALITY OF BEAD STIFFENERS COUPLED TO AN INNER SURFACE OF AT
LEAST ONE OF THE UPPER SKIN PANEL AND THE LOWER SKIN PANEL WITHIN
ONE OR MORE OF THE BAYS, THE BEAD STIFFENERS WITHIN THE ONE OR
MORE BAYS BEING SPACED APART FROM EACH OTHER AND ORIENTED NON-
PARALLEL TO THE FRONT SPAR AND HAVING A BEAD STIFFENER CAP HAVING
OPPOSING CAP ENDS RESPECTIVELY LOCATED PROXIMATE THE FRONT SPAR
AND THE MOVABLE SURFACE TRAILING EDGE

602

PLACING THE MOVABLE SURFACE IN A NON-LOADED CONDITION

604

PLACING THE MOVABLE SURFACE IN A LOADED CONDITION

606

FIG. 18

