

G. E. Jarvis, Rail Joint.

No. 92,833.

Patented July 20, 1869.

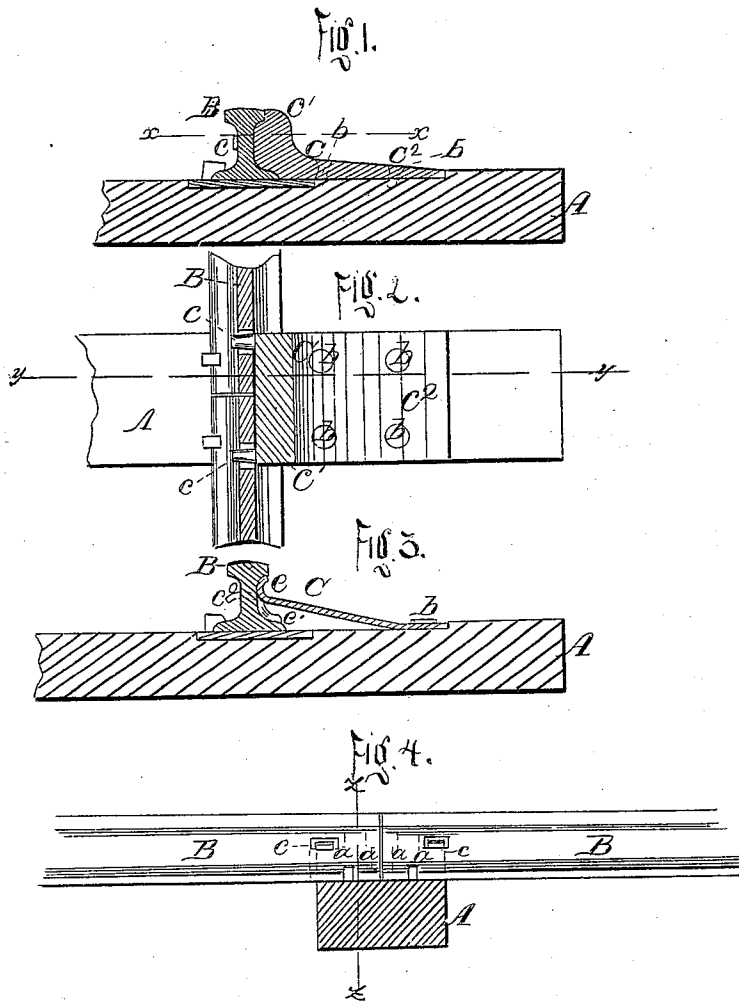

Witnesses:
G. A. Pettit
E. A. Allsworth

INVENTOR:
G. E. Jarvis
by Messrs
Attorneys.

United States Patent Office.

GRANVILLE E. JARVIS, OF GRAFTON, WEST VIRGINIA.

Letters Patent No. 92,833, dated July 20, 1869.

IMPROVED RAILWAY-RAIL JOINT.

The Schedule referred to in these Letters Patent and making part of the same.

To all whom it may concern:

Be it known that I, GRANVILLE E. JARVIS, of Grafton, in the county of Taylor, and State of West Virginia, have invented a new and improved Railroad-Joint and Track-Brace; and I do hereby declare that the following is a full, clear, and exact description of the construction and operation of the same, reference being had to the accompanying drawings, making a part of this specification, in which—

Figures 1 and 3 are longitudinal sections, representing different forms of the device.

Figure 2 is a horizontal section, representing the form shown in fig. 1.

Figure 4 is an end view representing the form shown in fig. 3.

The object of this invention is to provide a simple, cheap, and durable brace, adapted to be fastened to the cross-ties, so as to press against the outer side of the rail, and support it at the joints and elsewhere, and at the same time to hold the rail in place, and prevent its sliding or "working" endwise on steep grades.

In the drawings—

A A are the cross-ties;

B B, the rails; and

C, the brace.

In figs. 1 and 2, the latter is represented as composed of a heavy stout, shoulder, C¹, cast or struck up to fit the side of the rail and come even with its tread, supported by a long, flat base, c², which is countersunk in the upper side of the cross-tie, and held in position by bolts b b.

The shoulder C¹ is provided with projecting spurs c c, which extend through the rail and serve to hold it in position.

To allow of the expansion and contraction of the rail, the slots through which the spurs extend are made oblong.

Figs. 3 and 4 represent a simpler and cheaper form of brace than the above.

As here represented, the whole brace is struck up from a single flat plate of iron.

The iron is first cut to the proper size and shape; four (more or less) slits are then made in the end of it, as seen at a a a a; the central tongue e thus formed is bent up; the two e' e', adjacent to it, are bent down, and the ends of the two tongues e e, at the corners of the plate, are slightly bent, as seen at o; the plate is then drilled for the spikes, its outer end is slightly bent to make it fit the ties, and the device is ready for use. It is attached to the rail and ties in the same manner as that first herein described, and as will be clearly understood from fig. 3.

The object of the tongues e e' is (like the shoulder C¹) to press against the side of the rail and support it both laterally and vertically, while the tongues e e enter the lateral slots in the rail and hold the latter in position, as above described.

The ends o o are bent down so as to form hooks, which, when the plate is in place, come against the inner side of the rail and hold it from settling or bending inward.

These ends may be left straight at first, and may be bent down against the inner side of the rail by the track-layers.

The same construction may obviously be adopted in connection with that form of my device seen in figs. 1 and 2.

Having thus described my invention,

What I claim as new, and desire to secure by Letters Patent, is—

As an article of manufacture, a railroad-track brace made from a flat plate of iron, and having the bent-up tongues e e', the spurs c c, the long shank c², and the spike-holes, all arranged and constructed substantially as and for the purposes set forth.

To the above specification of my invention, I have signed my hand, this 29th day of March, 1869.

G. E. JARVIS.

Witnesses:

CHAS. A. PETTIT,

S. C. KEMON.