

(No Model.)

R. E. TERRY.
LOG CARRIER.

No. 526,758.

Patented Oct. 2, 1894.

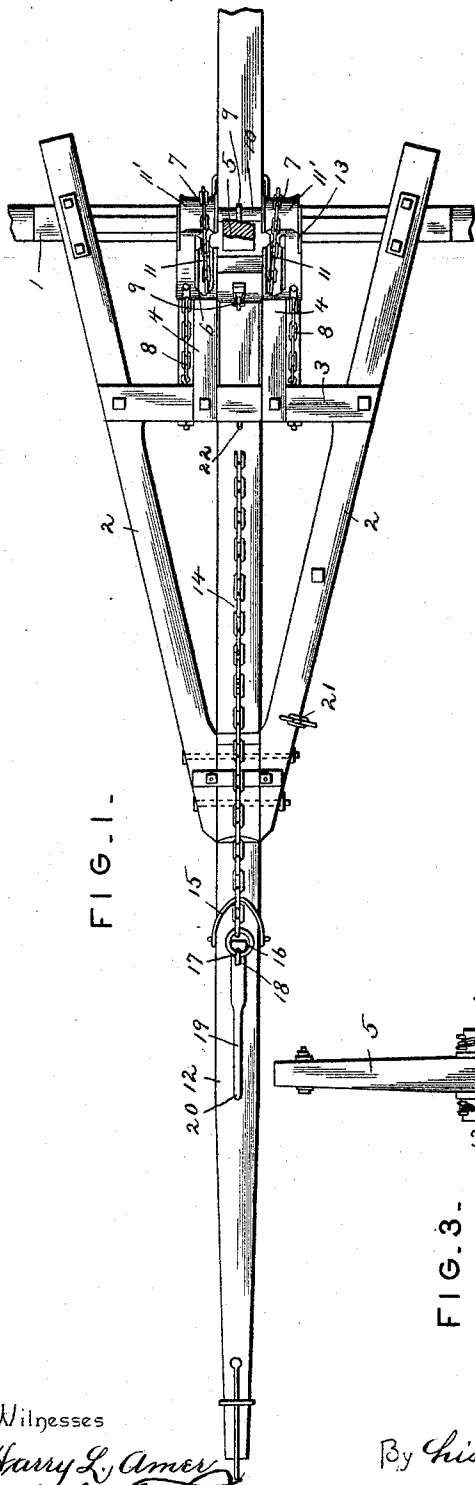

FIG. 1-

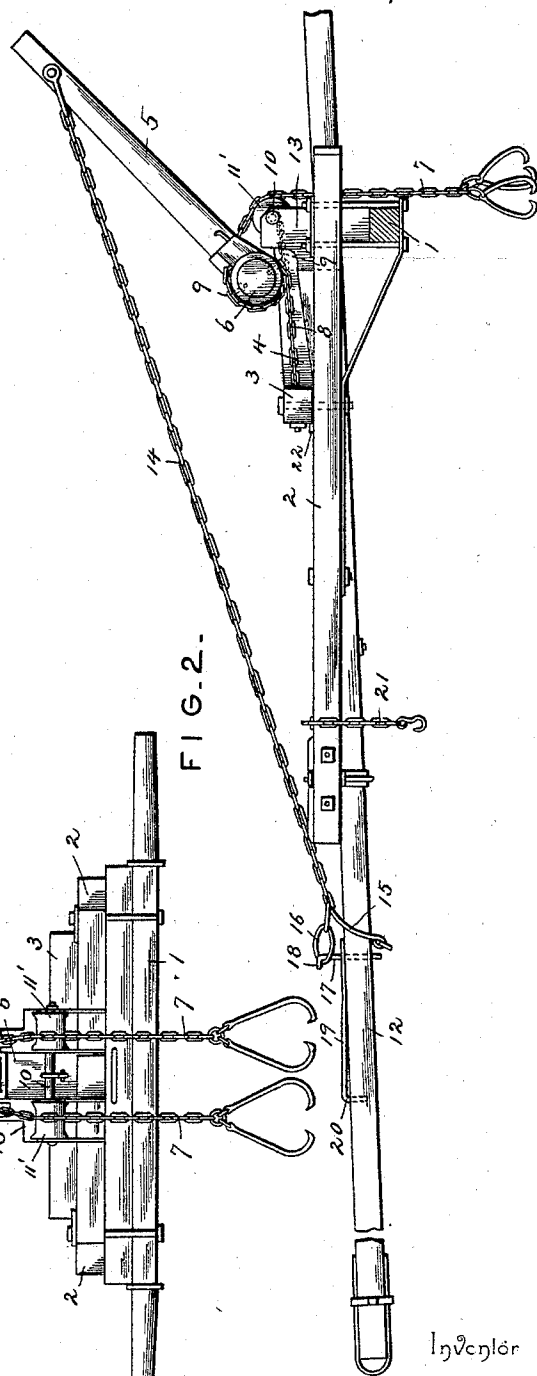

FIG. 2-

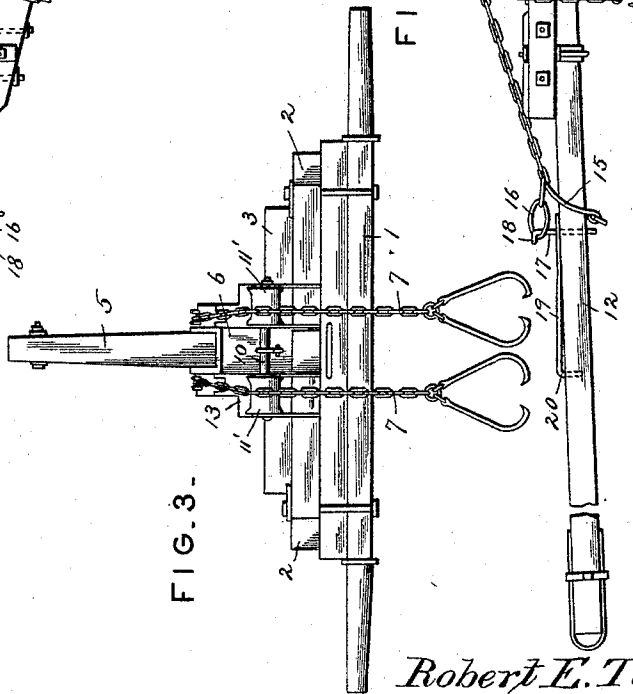

FIG. 3-

Inventor

Robert E. Terry.

Witnesses

Harry L. Ames
J. J. Ray

By his Attorneys.

C. A. Snow & Co.

UNITED STATES PATENT OFFICE.

ROBERT EMETT TERRY, OF MOBILE, ALABAMA.

LOG-CARRIER.

SPECIFICATION forming part of Letters Patent No. 526,758, dated October 2, 1894.

Application filed December 7, 1893. Serial No. 493,036. (No model.)

To all whom it may concern:

Be it known that I, ROBERT EMETT TERRY a citizen of the United States, residing at Mobile, in the county of Mobile and State of Alabama, have invented a new and useful Log-Carrier, of which the following is a specification.

The invention relates to improvements in log carriers.

The object of the present invention is to simplify and improve the construction of log carriers, and to provide one in which a log will be lifted by the draft animals, and which will lessen the force of the pull required to lift a log.

A further object of the invention is to increase the efficiency of the class of log carriers, which employ a swinging lever to lift the log chains, by enabling the log chains to be carried upward a much greater distance, with a given swing to the lever, than has heretofore been possible.

The invention consists in the construction and novel combination and arrangement of parts hereinafter fully described, illustrated in the accompanying drawings and pointed out in the claims hereto appended.

In the drawings Figure 1 is a plan view of a log carrier constructed in accordance with this invention. Fig. 2 is a side elevation of the same. Fig. 3 is a rear elevation.

Like numerals of reference indicate corresponding parts in all the figures of the drawings.

1 designates an axle, having journaled on its spindles suitable carrying wheels (not shown) and supporting a frame composed of hounds 2, a transverse bar 3, and a pair of longitudinal parallel bars 4, forming a track or way for a lever 5, which has a shifting or rolling fulcrum 6, whereby log chains 7 will be wound up with greater rapidity, and with less pull than would be the case were the levers provided with a fixed fulcrum. The lever 5 is composed of a roller and a handle, and it is guided in its movement by chains 8 and 9, which are wound around or arranged on the rounded end of the lever in opposite directions. The chains 8 and 9 are three in number, two extending forward and attached to the transverse bar 3 and arranged at opposite sides of the lever and the other one

being arranged at the middle of the rounded end 6 and extending rearward to a shaft 10; and when the lever is swung forward in raising a log the chains 8 are wound on the rounded end 6, while the chain 9 is unwound; and when the lever swings rearward a reverse operation of the chains take place.

The log chains have their upper ends secured to the enlarged portion 6 of the lever and are arranged in grooves 11 thereof, to prevent any lateral slipping; and they pass over sheaves or drums 11' arranged at the rear end of the frame and mounted on the shaft 10. A forward swinging of the lever not only winds the log chain around its enlarged portion, but it also causes the enlarged portion of the lever to roll forward on the track bars 4, thereby drawing on the chain and increasing the lift of the log carrier and requiring a less pull to lift a log than would be the case were the lever mounted on a fixed fulcrum or pivot.

The lifting of a log is effected by the draft animals which are attached to a sliding tongue 12, and the latter is slidingly mounted between the hounds, and it extends rearward between the longitudinal track bars 4 and the bearings 13 at the rear ends thereof. The sliding tongue is connected with the upper end of the lever 5 by means of a chain 14, which is provided at its front end with a loop 15 receiving the sliding tongue. The chain is detachably connected with the sliding tongue by means of an enlarged link or ring 16 and a vertical pin 17 provided at its upper end with a hook or head 18 preferably formed by bending the upper end of the pin at right angles. The pin is adapted to be turned to carry its head around over the opening of the link 16 to permit the latter to readily slip off of it when it is desired to drop the logs. The pin is held against accidental turning by a spring bar or resilient catch 19, having its rear end secured to the pin, and having its front end bent downward to form a projection or lug 20 to engage a perforation or recess of the sliding tongue. The resilient bar or catch serves as a handle for turning the pin, and a log may be readily dropped without inconvenience or labor. A supplemental chain 21 is secured to the frame, and is provided with a hook adapted to engage a

link of the chain 14, to secure the lever against rearward movement in loading the carrier when it is desired to shorten the tongue, and the latter is provided at intervals with perforations to permit the pin 17 to be arranged at the desired point. The tongue is held against accidental rearward movement, and to take the strain of the log from the neck of the animal by a detachable pin 22, arranged in one of the perforations of the tongue and located adjacent to the transverse bar 3 in advance thereof.

The log chains are provided at their lower ends with suitable grapples for engaging a log. In the operation of the log carrier, when the tongue is drawn outward by the draft animals to lift a log, the rolling lever 5 is swung forward and the log chains are wound around the roller portion of the lever owing to the rotation of the same, and they are carried upward in excess of the mere winding action, by the forward rolling movement of the lever on the frame. If the lever was permanently pivoted at one point, the direct rotation would alone operate to lift the log, but the rolling movement greatly increases the leverage and produces an additional lifting of the log, all of which is effected by the draft animals, with greater ease, as the swing of the lever is lessened to a given lift of the log over the simple pivoted lever.

It will be readily seen that the log carrier is simple and comparatively inexpensive in construction, and that it increases the facility for lifting logs, and enables them to be readily dropped when desired.

Changes in the form, proportion and the minor details of construction may be resorted to without departing from the principle or sacrificing any of the advantages of this invention.

What I claim is—

1. In a log carrier, the combination with an axle, of a frame supported by the same, a lever mounted on the frame and having a rounded lower end forming a rolling or shifting fulcrum, limiting devices for the movement of the same, and a log chain connected with the lever, substantially as and for the purpose described.

2. In a log carrier, the combination with an axle, of a frame mounted thereon, a lever having a rounded lower end forming a rolling or shifting fulcrum, chains having their adjacent ends attached to and oppositely disposed on the rounded end of the lever and extending therefrom in opposite directions and connected with the frame for guiding the lever, and a log chain connected with the lever, substantially as and for the purpose described.

3. In a log carrier, the combination with an axle, of a frame supported thereon and provided with parallel track bars, a lever having an enlarged rounded lower end arranged on the track bars and forming a rolling or shift-

ing fulcrum and provided at opposite sides with grooves, the chains 8 and 9 having their adjacent ends secured to and arranged on the rounded end of the lever and extending therefrom in opposite directions and connected with the frame, a pair of sheaves arranged at the rear end of the frame, and log chains passing over the sheaves and secured to the lever and arranged in the grooves of the enlarged end thereof, substantially as described.

4. In a log carrier, the combination with an axle, of a frame mounted thereon, a tongue slidingly arranged in the frame, a lever mounted on the frame and carrying a log chain, a draft chain 14 having its rear end connected with the lever, and a rotatable pin mounted on the tongue and adapted to receive a link of the chain and provided at its upper end with a head, substantially as and for the purpose described.

5. In a log carrier, the combination with an axle, of a frame mounted thereon, a tongue slidingly arranged in the frame, a lever mounted on the frame and carrying a log chain, a rotatable pin mounted on the tongue and provided at its upper end with a head and having fixed to it a resilient bar extending along the tongue and having a projection engaging the same, and a draft chain having its rear end secured to the lever and provided at its front end with a link engaging said pin, substantially as described.

6. In a log carrier, the combination with an axle, of a frame, a lever mounted on the frame, a draft chain having its rear end attached to the lever and provided at its front end with a loop 15 and having a link 16 adjacent to the loop 15, a tongue slidingly mounted on the frame and having the loop 15 arranged on it, a vertical pin rotatively mounted on the tongue and having its upper end bent at an angle and engaging the link 16, and a resilient bar fixed to the pin and serving as a handle for turning the same and provided with a projection engaging the tongue, substantially as described.

7. In a log carrier, the combination with wheels, axle and frame, of a rolling lever adapted to roll on said frame and having an upright handle, guide chains secured to the frame in front and rear of the roller and secured to the roller and winding on the same in reverse directions, a log chain secured to the roller, a sliding tongue, and a flexible connection between the tongue and the upright handle, substantially as described.

In testimony that I claim the foregoing as my own I have hereto affixed my signature in the presence of two witnesses.

ROBERT EMETT TERRY.

Witnesses:

LESLIE B. SHELDON,
B. L. STAFFORD.