



(11) **EP 1 930 449 A2**

(12) **EUROPEAN PATENT APPLICATION**

(43) Date of publication:
11.06.2008 Bulletin 2008/24

(51) Int Cl.:
C21B 13/02 (2006.01) F27B 1/00 (2006.01)
F27D 17/00 (2006.01)

(21) Application number: **07023877.9**

(22) Date of filing: **10.12.2007**

(84) Designated Contracting States:
AT BE BG CH CY CZ DE DK EE ES FI FR GB GR HU IE IS IT LI LT LU LV MC MT NL PL PT RO SE SI SK TR
Designated Extension States:
AL BA HR MK RS

(71) Applicant: **Mines and Metals Engineering (M.M.E.) 40474 Düsseldorf (DE)**

(72) Inventor: **Najmossadat, Seyed Mohammed Reza Aorfie Shirazi (Ghaarbi) Str. Nr. 73, Teheran (IR)**

(30) Priority: **10.12.2006 IR 38200**
21.12.2006 DE 102006062689

(74) Representative: **Paul, Dieter-Alfred et al Patentanwalt Hellersbergstrasse 18 41460 Neuss (DE)**

(54) **Shaft furnace**

(57) The invention refers to a vertical shaft furnace (100) for a burden (115) moving under the influence of gravitation from the top to the bottom of the shaft furnace, in particular for the production of directly reduced iron, with a hot reduction zone (101) and a cooling zone (103) following the reduction zone (101), in which feed openings for a cooling gas (165) are provided, and with a cooling gas collecting member (160) which is provided in a transition portion between the reduction zone (101) and the cooling zone (103), which is characterized in that the cooling gas collecting member (160) comprises collector arms (181-184) arranged in cross shape, each of which forms a cooling gas off-take (170-173).

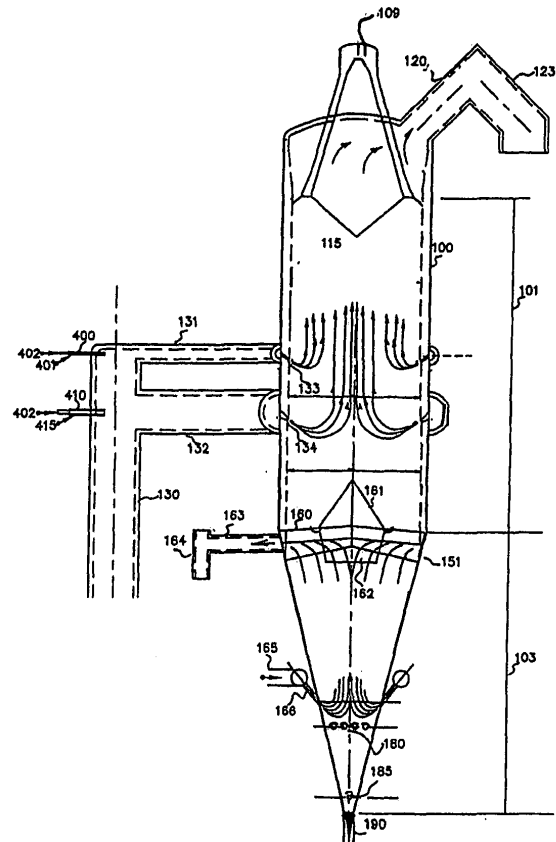

Fig. 1

EP 1 930 449 A2

Description

[0001] The present invention relates to a vertical shaft furnace for a burden moving under the influence of gravitation from the top to the bottom of the shaft furnace, in particular for the production of directly reduced iron, with a hot reduction zone and a cooling zone following the reduction zone, in which feed openings for a cooling gas are provided, and with a cooling gas collecting member which is provided in a transition portion between the reduction zone and the cooling zone.

[0002] Vertical shaft furnaces are known in the prior art, which may in particular be used for the direct reduction of iron oxides. These shaft furnaces are designed in such a way, that the burden fed thereto move under the influence of gravity from the top to the bottom of the shaft furnace.

[0003] US 4,054,444 discloses such a shaft furnace. In this shaft furnace a feed opening for the burden and furnace gas outlet are provided at the top of the shaft furnace. A burden of iron oxide material may be fed into the shaft furnace through the feed opening. The furnace gas outlet serves for discharging used furnace gas.

[0004] The feed opening forms the upper end of a reduction zone, in which gas bustle ports are provided in order to introduce reduction gas, which contains carbon monoxide and hydrocarbon and is produced in a reformer. Reduction gas reduces the iron oxide at high temperatures directly into iron.

[0005] The reduction zone is followed by a transition zone where hot material passes to a cooling zone with minimum changes in the chemistry of the product.

[0006] Just below the transition zone and cooling zone upper cone area a cooling gas collecting chamber is provided. The cooling gas collecting chamber is for receiving hot cooling gas, which has passed through the hot DRI material cooling zone, and recycling it through the cooling gas scrubber to the cooling zone of the furnace. In this way the DRI is cooled, prior to discharge through the bottom of the shaft furnace discharge feeder.

[0007] A cooling gas collecting member is, however, provided in the central part of the shaft furnace. In this way on both sides narrow portions remain in the transition region from the reduction zone to the cooling zone, through which cooling gas may pass into the reduction zone, because no measures are taken to prevent this. As a result the entry of cooling gas into the reduction zone is not effectively prevented, which leads to an undesired cooling of the burden in this zone. In this way more thermal energy has to be fed to the reduction zone in order to maintain the reduction reaction.

[0008] It is thus the object of the present invention to provide shaft furnace, wherein the entry of cooling gas into the reduction zone is effectively prevented.

[0009] This object is solved in a shaft furnace of the initially mentioned kind in that the cooling gas collecting member comprises collector arms arranged in cross shape, each of which forms a cooling gas off-take.

[0010] By the provision of collector arms arranged in cross-shape a transition from cooling gas from the cooling zone into the reduction zone is prevented. Accordingly there is no undesired cooling effect in the reduction zone, so that the efficiency of the shaft furnace is improved.

[0011] According to a first embodiment of the invention it is provided, that the cooling gas off-takes have a cross sectional area increasing beginning from the crossing point towards the exterior side.

[0012] Also it is possible that the collector arms are slanted from the horizontal in the flow direction of the burden. In particular the collector arms may be slanted in an angle between 5 to 10° from the horizontal direction. In this way the collector arms offer a reduced resistance to the flowing burden.

[0013] According to a further embodiment of the invention the collector arms each have an edge for breaking the burden, which is oriented against the flow direction of the burden. In this way the burden may even more easily pass by the cooling gas collecting member.

[0014] In particular the collector arms may be connected to each other at their outer edge portions. In this way an additional stability of the cooling gas collecting elements is obtained.

[0015] According to a further preferred embodiment of the invention it is provided, that the cooling gas collecting member comprises at least one cone, wherein the cone tip is oriented opposite to the flow direction of the burden. Such a cone breaks the burden in the direction of the shaft furnace side walls.

[0016] The shaft furnace may furthermore comprise at least one gas pipe which is provided to discharge a hydrocarbon gas into the cone. In this way the cone is cooled, so that its durability is improved.

[0017] An upper cone may be provided relative to the flow direction of the burden before the connector arms. By means of this upper cone the burden is easily passed by the crossing portion of the connector arms.

[0018] The shaft furnace may also comprise a lower cone, which in relation to the flow direction of the burden is arranged behind the connector arms. This lower cone may be arranged directly at the base face of the upper cone between the collector arms. The lower cone supports the uniform flow of the burden.

[0019] An embodiment of the present invention will be described in detail making reference to the attached drawing. In the drawing show

Figure 1 a schematic side elevational view of a shaft furnace according to the present invention,

Figure 2 an enlarged view of a cooling gas collecting member of the shaft furnace according to figure 1,

Figure 3 an enlarged top view of the cooling gas collecting member of the shaft furnace of figure 1, and

Figure 4 an enlarged side elevational view of the cooling gas collecting element of the shaft furnace of figure 1.

[0020] Figure 1 shows a shaft furnace 100 according to the present invention in schematic view, which is in particular adapted for the production of directly reduced iron. The shaft furnace 100 has a generally cylindrical form and is vertically arranged.

[0021] A furnace exit gas outlet 120 is provided at the top of the shaft furnace 100, the central axis of the shaft furnace outlet 120 being inclined with regard to the horizontal axis of the shaft furnace 100 by an angle of 45 to 55°. The furnace gas outlet 120 is connected with a furnace gas main pipe 123 in such a way, that the central axis of the furnace gas outlet 120 and of the furnace gas main pipe 123 turn at an angle of 90°.

[0022] Moreover a feed opening 109 for a burden 115 of iron oxide material is provided at the top of the shaft furnace 100. The shaft furnace 100 is designed in such a way, that the burden 115 will move under the influence of gravity from the top to the bottom of the shaft furnace downwardly through the interior of the shaft furnace 100.

[0023] The interior of the shaft furnace 100 is divided into a reduction zone 101, the upper end of which forms the feed opening 109, and a cooling zone 103, which is arranged immediately underneath the reduction zone 101.

[0024] At the lower end of the cooling zone 103 a discharge opening 190 is provided, through which the reduced iron may be discharged from the shaft furnace 100.

[0025] The shaft furnace 100 comprises a reducing gas feeding device 130, which is connected with two bustle gas lines 131, 132 with two sets of bustle gas ports 133, 134. The bustle gas ports 133, 134 are arranged at two vertically different levels on the periphery of the shaft furnace wall.

[0026] Both bustle gas lines 131, 132 are equipped with an injection system 400, 410 for a gas mixture. The two injection systems 400 410 are each connected with a hydrocarbon source 401, 415 and an oxygen source 402, wherein the two hydrocarbon sources 401, 415 may differ from one another. Both injection systems 400, 410 are designed in such a way, that the amount of hydrocarbon and oxygen may be regulated separately.

[0027] Figure 2 shows an enlarged side view of the injection system 400. The injection system 400 comprises two lines 403, 404, wherein the line 403 is connected with the hydrocarbon source 401 and the line 404 is connected with the oxygen source 402. The line 403 runs coaxially within the line 404, and both lines are connected to a mixing portion 405. The mixing portion 405 has a discharge opening 406 for the hydrocarbon-oxygen-mixture.

[0028] In the cooling zone 103, cooling gas nozzles 166 are provided on the shell, which are connected with a cooling gas inlet header 165. A cooling gas collecting member 160 is provided in the lower part of a transition

zone between the reduction zone 101 and the cooling zone 103.

[0029] The cooling gas collecting member 160 is shown in figures 3 and 4 in an enlarged scale. It comprises invertedly tapered channels formed in collector arms 181, 182, 183, 184 arranged in a cross shape, each of which forms a cooling gas off-take 170, 171, 172, 173. The lower side of the collector arms 181, 182, 183, 184 opposite to the shaft furnace bottom have suction openings for the cooling gas formed therein. The cross sectional area of the cooling gas off-takes 170, 171, 172, 173 increases beginning from the crossing point towards the exterior side.

[0030] Moreover the collector arms 181, 182, 183, 184 are inclined with an angle between 5 and 10° from the horizontal direction in the direction of the shaft furnace shell.

[0031] The collector arms 182, 183 and 183, 184 and 181, 184 are connected at their outer edge portions to each other, so that all collector arms 181, 182, 183, 184 form a common off-take header. The off-take header is connected with an outlet 164, in which a suction device may be provided.

[0032] The cooling gas collecting member 160 is further provided with an upper hollow cone 161, which is provided above the collector arms 181, 182, 183, 184 in the center thereof (see fig. 4). The upper cone 161 is hollow. Moreover a lower cone 162 is provided, which in relation of the flow direction of the burden 115 is positioned behind (beneath) the collector arms 181, 182, 183, 184 in the center thereof.

[0033] A gas pipe 151 is connected to the hollow interior of the upper cone 161 and is connected to hydrocarbon source which is not shown in the drawing.

[0034] In the lower third part of the cooling zone 133 rotating shafts 180, 185 are provided for breaking and grinding clusters, if present.

[0035] During operation of the shaft furnace 100 the burden 115 of iron oxide material is fed through the feed opening 109, into the reduction zone 101. At the same time a hot reduction gas of hydrogen and carbon monoxide is blown into the reduction zone 101 through the bustle gas ports 133, 134 in such a way, that it flows in the opposite direction of the burden 115, which flows downwardly under the influence of gravity. Thus the reduction gas reduces the iron oxide at high temperature and in direct contact with the iron.

[0036] The reacted reduction gas then reaches the shaft furnace top, where it enters the furnace gas outlet 120. Due to the inclination of the furnace gas outlet 120 only a small amount of dust particles reaches the furnace gas main pipe 123, because gravity restrains the dust particles.

[0037] The reduced burden 115 descends from the reduction zone 101 into the cooling zone 103. On its way it passes the cooling gas collecting member 160, thereby passing between the collector arms 181, 182, 183, 184, which offer a comparatively small resistance. At the same

time the burden 115 is loosened by the top cone 161 in the direction of the shaft furnace wall. The top cone 161 is cooled by the gas entering into the interior thereof.

[0038] In the lower part of the cooling zone 102 a cooling gas is blown in by way of the cooling gas ports 166. The cooling gas streams upwardly against the descending burden 115 thereby cooling the burden 115. Finally hot gas reaches the collector arms 181, 182, 183, 184 and exits through the suction openings thereof into the cooling gas off-takes 171, 172, 173, 174. The cooling gas is then passed to the cooling gas offtake header 164 through the cooling gas off-takes 171, 172, 173, 174 and is thus effectively removed from the shaft furnace 100 at the lower limit of the cooling zone 103. In this way, the cooling gas is effectively prevented from entering into the reduction zone 101.

[0039] The cooled-off burden 115 finally discharges through the discharge port 190 from the shaft furnace 100.

Claims

1. Vertical shaft furnace (100) for a burden (115) moving under the influence of gravitation from the top to the bottom of the shaft furnace, in particular for the production of directly reduced iron, with a hot reduction zone (101) and a cooling zone (103) following the reduction zone (101), in which feed openings for a cooling gas (165) are provided, and with a cooling gas collecting member (160) which is provided in a transition portion between the reduction zone (101) and the cooling zone (103), **characterized in that** the cooling gas collecting member (160) comprises collector arms (181-184) arranged in cross shape, each of which forms a cooling gas off-take (170-173).
2. A shaft furnace (100) according to claim 1, **characterized in that** the cooling gas off-takes (171-173) have a cross sectional area increasing beginning from the crossing point towards the exterior side.
3. Shaft furnace (100) according to any preceding claim, **characterized in that** the collector arms (181-184) are slanted from the horizontal in the flow direction of the burden (115).
4. Shaft furnace (100) according to claim 3, **characterized in that** the collector arms (181-184) are inclined in an angle between 5 to 10° from the horizontal direction.
5. Shaft furnace (100) according to any preceding claim, **characterized in that** the collector arms (181-184) each have an edge for breaking the burden (115), which is oriented against the flow direction of the burden (115).
6. Shaft furnace (100) according to any preceding claim, **characterized in that** the collector arms (181-184) are connected to each other in particular at their outer edge portions.
7. Shaft furnace (100) according to any preceding claim, **characterized in that** a cooling gas collecting member (160) comprises at least one cone (161, 162), wherein the cone tip is oriented opposite to the flow direction of the burden (115).
8. Shaft furnace (100) according to claim 7, **characterized in that** it comprises at least one gas pipe (150) provided to discharge a hydrocarbon gas into the cone (161, 162).
9. Shaft furnace (100) according to claim 7 or 8, **characterized in that** an upper cone (161) is provided relative to the flow direction of the burden (115) before the collector arms (181-184).
10. Shaft furnace (100) according to any of claims 7 to 9, **characterized in that** a lower cone (162) is provided relative to the flow direction of the burden (115) behind the collector arms (181-184).
11. Shaft furnace (100) according to claim 10, **characterized in that** the lower cone (162) is provided directly at the base face of the upper cone (161) between the collector arms (181-184).

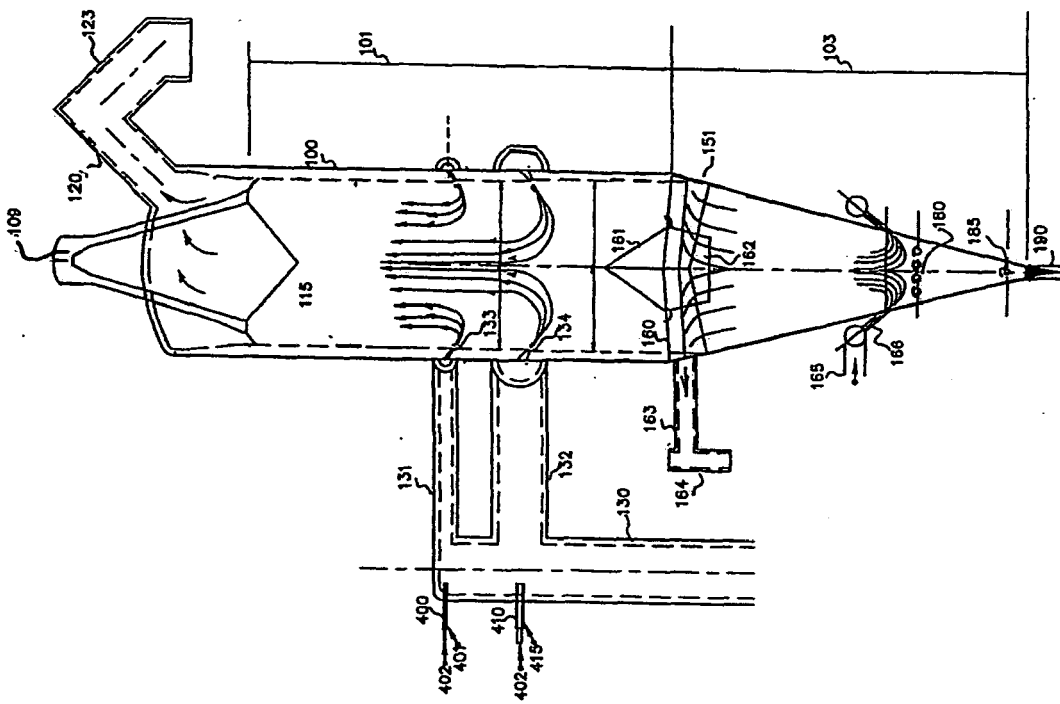

Fig. 1

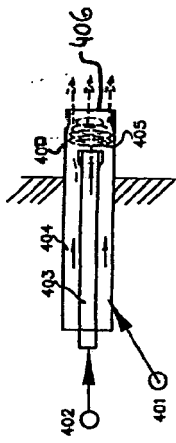

Fig. 2

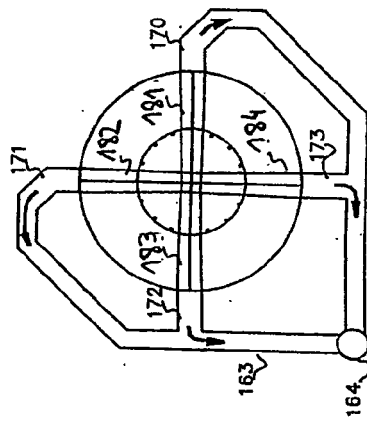

Fig. 3

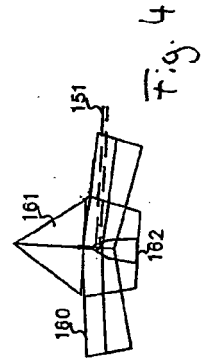

Fig. 4

REFERENCES CITED IN THE DESCRIPTION

This list of references cited by the applicant is for the reader's convenience only. It does not form part of the European patent document. Even though great care has been taken in compiling the references, errors or omissions cannot be excluded and the EPO disclaims all liability in this regard.

Patent documents cited in the description

- US 4054444 A [0003]