

(54) 가

(20) q 1 p 2
 (20) -가 (22) 1 2 1 2
 가
 q q₁ , 2 q₂ , q₁ q₂ , 1 , p p₁ , 2
 p p₂ p₂ p₁ . p₁ q₁ p₂ q₂ . (20) 가 1
 (20) 2

1

가

, 가 가 (translate)
 , 가 -가

, 3

(flexible wiring harness)

(TAB: Tape Automated Bonding)

TAB

. TAB
 가

(usefulness)

가

가

, 가 /

가 , q 1 p 2 -가
 .
 . 1 2 가 -가 1 2 -
 가 1 2 가 , q 1 q 1 , 2 q 2 , q 1 q 2
 .가 , q 1 q 2 , p p 1 , 2 , p
 p 2 , p 2 가 p 1 .가 , p 2 가 p 1 .가 , 1 , p
 p 1 q 1 2 p 2 q 2 . 가 1
 2 .

1 , 2 , 가 , 2
 . , 1 가 / ,

가 , (가)

1

2

3a 3b

TAB

4a 4b

-가

5a 5h

-가

6a 6b

1 (10) (14) (18) (12) (10) 가 (16)
 . (12) (18) (18) (12) -
 . (12) (14) 2 ()

가) (pixel - to - pixel) (18) , (12)
" (rasterizes)" .

(18) (16)
3 3 , 1, 2 3 . 1, 2
(quad) ,

1 2 , (10) (16)
(20) (20) (22) .
- (16)
-가 (12) (14) (22)
(16)

1 , (10) (26) (20)가 (14) 가
(24) (24)
(carriage) , 가
(16)

(10) (28) (16)
30) (28) (20) (14)가 (swath) (14)가 ()
(12) (14) (platen)
(stepper motor) (28) (14)

1 (31) (Q, P)
A) (20) . 1 (Q) q (quad) ,
2 (A) n , 3 (P) p
, q, n p
(10) /가 .

(20) , (TAB)
(32)가 (22) TAB (32) . TAB (32)
TAB (32)가 2 (20) (34) ()
10) TAB (32) (Q, P A) TAB (32) TAB (36)
. TAB (36) (22) TAB (32)
. 2 (38) , TAB (36)

(22) 가 . , TAB
 (32) (31) (10) /가

3a 3b (22) (22) 가 가
 TAB (32) (40) , (40) ,
 (CA1 CA10) (CQ1 CQ4) q₁ 1 ,
 p₂ 2 , (CP1 CP16)
 , q₁ 4 , n 10 , p₂ 16
 가 (ink via)(42)가 (22) (42)
 가 (44a 44b)

3a (10) 1 (40) 가 , 3b
 2 (40) 가 . TAB (32)
 , (10) /가 가 (22)
 (10)

(320) -가 (R1 R320) 4a 4b
 , (R1 R320) (46a 46b) (22) 4a (46a
 46b) , 4b 20 (R1 R160) (46a) (44a)
 (3a 3b) , (R161 R320) (46b) (44b)
 , (46a) (46b) 1/2
 , 1/600inch(0.00423cm)

16 - - 10
 , - 10 1/1200inch(0.00212cm)
 , - 10 1/150inch(0.017cm) 4a 4b
 , - 가 1/2
 , 1/300inch(0.00847cm)
 , -
 , 1/600inch(0.00423cm) , 4a 4b
 (46a 46b)

5a 5h (22)
 , -가 (R1 R320) , (Q1 Q4)
 (A1 A10) (P1 P16) (R1
 R320) - (pass - gate) (P
 G1 PG320), (D1 D320) - (PD1 PD320) 1,
 2 3 , - (PG1 PG320) -

(PD1 PD320) JFET , (D1 D320) NMOS .

-가 (R1 R320) (P1 P16) (high side) ,
 (D1 D320) 2 (low side)
 (D1 D320) (common ground return)
 2 (D1 D320) 2
 (D1 D320) 가 (D1 D320)가 " "
 (D1 D320)가 " " ,
 (R1 R320) (P1 P16) 가 , -가 (R1 R320)
 (R1 R320) (R1 R320) , (R1 R320)

(D1 D320) 가 (D1 D320)가 " "
 (Q1 Q4) 5a 5h ,
 (A1 A10) (PG1 PG320) 1
 (Q1 Q4) - 가 (PG1 PG320) " " ,
 (A1 A10) - (PG1 PG320) PG3
 20) 1 (PG1 PG320)
 (D1 D320) 1 - (PG1 P
 (PG1 PG320)가 " " (가), (PG1 P
 (D1 D320)
 가 (PG1 PG320)
 (D1 D320) " " .

5a 5h (PD1 PD320) (D1 D320) - (PD1 PD320)가 (D
 1 D320) , - (PD1 PD320)
 (PD1 PD320) (PD1 PD320)가 " "
 (D1 D320) (D1 D320) " " (PD1 PD320)가 " " ,
 (PD1 PD320) (22) -

5a (R1 R20) (P1) (R161 R180) (
 P2) (P1) 1
 (P2) 2 (P1 P2) (CP1 C
 P2)
 (PG1 PG19 PG161 PG179) (Q1)
 (PG2 PG20 PG162 PG180) (Q2)
 (Q1) 1
 (Q2) 2

	-	(PD1	PD19	PD161	PD179)	-	(Q2P)
	,	(PD2	PD20	PD162	PD180)	-	(Q1P)
5b	,	(R21	R40)	(P3)	,	(R181	R200)
(P4)	.	,		(P3)	,	3	
P4)	(P4)		4			(P3	P4)
							(CP3
	-	(PG21	PG39	PG181	PG199)		(Q3)
	,	(PG22	PG40	PG182	PG200)		(Q4)
	.	,		(Q3)		3	
	(Q4)		4				
	-	(PD21	PD39	PD181	PD199)	-	(Q4P)
	,	(PD22	PD40	PD182	PD200)	-	(Q
3P)	.						
	,	(A)	10	(A1	A10)		
	-						
5a	5b			5c	5h		
				(P5	P16)	(CP5	CP16)
	5g	5h		(Q1	Q4)	(CQ1	CQ
4)	,			(CQ1P	CQ4P)	,	
	(A1	A10)	(Q1P	Q4P)	-		
			(CA1	CA10)			
	1,	2,	3	4			

	Q1									
	A1	A2	A3	A4	A5	A6	A7	A8	A9	A10
P1	R1	R15	R9	R3	R17	R11	R5	R19	R13	R7
P2	R161	R175	R169	R163	R177	R171	R165	R179	R173	R167
P5	R41	R55	R49	R43	R57	R51	R45	R59	R53	R47
P6	R201	R215	R209	R203	R217	R211	R205	R219	R213	R207
P9	R81	R95	R89	R83	R97	R91	R85	R99	R93	R87
P10	R241	R255	R249	R243	R257	R251	R245	R259	R253	R247
P13	R121	R135	R129	R123	R137	R131	R125	R139	R133	R127
P14	R281	R295	R289	R283	R297	R291	R285	R299	R293	R287

	Q2									
	A1	A2	A3	A4	A5	A6	A7	A8	A9	A10
P1	R2	R16	R10	R4	R18	R12	R6	R20	R14	R8
P2	R162	R176	R170	R164	R178	R172	R166	R180	R174	R168
P5	R42	R56	R50	R44	R58	R52	R46	R60	R54	R48
P6	R202	R216	R210	R204	R218	R212	R206	R220	R214	R208
P9	R82	R96	R90	R84	R98	R92	R86	R100	R94	R88
P10	R242	R256	R250	R244	R258	R252	R246	R260	R254	R248
P13	R122	R136	R130	R124	R138	R132	R126	R140	R134	R128
P14	R282	R296	R290	R284	R298	R292	R286	R300	R294	R288

	Q3									
	A1	A2	A3	A4	A5	A6	A7	A8	A9	A10
P3	R21	R35	R29	R23	R37	R31	R25	R39	R33	R27
P4	R181	R195	R189	R183	R197	R191	R185	R199	R193	R187
P7	R61	R75	R69	R63	R77	R71	R65	R79	R73	R67
P8	R221	R235	R229	R223	R237	R231	R225	R239	R233	R227
P11	R101	R115	R109	R103	R117	R111	R105	R119	R113	R107
P12	R261	R275	R269	R263	R277	R271	R265	R279	R273	R267
P15	R141	R155	R149	R143	R157	R151	R145	R159	R153	R147
P16	R301	R315	R309	R303	R317	R311	R305	R319	R313	R307

(CQ1, CQ2, CQ3 CQ4) , TAB (32) (LP3, LP4, LP7, LP8, LP11, LP12, LP15 LP16) (22) (CP3, CP4, CP7, CP8, CP11, CP12, CP15 CP16) , TAB (32) (LA1 LA10) (22) (CA1 CA10) . TAB (32) - (jumper) (JQ1P, JQ2P, JQ3P JQ4P) (LQ1, LQ2, LQ3 LQ4) (22) - (CQ1P, CQ2P, CQ3P CQ4P) . TAB (32) (JP1, JP2, JP5, JP6, JP9, JP10, JP13 JP14) (CP 1, CP2, CP5, CP6, CP9, CP10, CP13 CP14) (LP3, LP4, LP7, LP8, LP11, LP12, LP15 LP16)

3a TAB (P1 P3 , P2 P4 , P5 P7 , P6 P8 , P9 P11 , P10 P12 , P13 P15 P14 P16). , 가 16 8 , 8 - 가 (R1 R320) 40 (q₁ x n = 4 x 10)가 (16) (22) 22 8 (p = p₁ = 8), 4 (q = q₁ = 4) 10 (n = 10) , TAB (32) 1 , 22 가 (31) , 22 (36) TAB (32) , 1 (10) 가 .

6a , (22) 1 . 6a , (Q1 Q4) (46a 46d) 31.245μs . 46d) (46a 46d) , (A1 A10) 2.6μs (1 6) , (48) 가 . (48) , (1 (P1, P2, P5, P6, P9, P10, P13 P14) 1 , (20)가 (14) 가 가 (enabled) 40 (q₁ x n = 4 x 10) , 40 8 (p₁ = 8) 가

TAB (32) (LQ1)가 - (CQ1P) , - (PD2 PD20 PD162 PD180) (46a) , " " 2 (PD2 PD20 PD162 PD180) (46a) " " , TAB (32) (LQ2)가 - (CQ2P) , (PD1 PD19 PD161 PD179) (46b) " " 1 (PD1 PD19 PD161 PD179) (46b) 가 " " , (PD21 PD40 PD181 PD200) 가 (46a 46b) " " , Q1 Q2 가 - (P D22 PD40 PD182 PD200) (46c) , " " 3 가, (PD22 PD40 PD182 PD200) (46c) " " (LQ3)가 - (CQ3P) , - (PD21 PD39 PD181 PD199) (46d) , " " PD21 PD39 PD181 PD199) (46d) " " 가, (PD1 PD20 PD161 PD 180)가 (46c 46d) " " 가 , Q3 Q4 가 - .

6a (transitions) , (24) (20) (14)
 가 (20)가 Q4가 Q3, Q2 Q1 가
 1 (20) 26.67inch(67.74cm)
 /s (48) (20) 6.93×10^{-5} inch(1.7
 6×10^{-4} cm) (46a 46d) (20) 8.33×10^{-4}
 (1/1200)inch(2.12×10^{-3} cm) (20)가 (R1 R320)
 4/1200(1/300)inch(0.00847cm)
 1 가 가 (checkerboard
 pattern) (14) ((14)
 14) 1/600inch(0.0042cm) 4 가 , 4
 가 (20)가 (14) 가 4
 3b (22) 2 TAB (32) 2 (C
 Q1 CQ2) , TAB (32) (LQ1 LQ2) (22) (CP1
 CP16) , TAB (32) (LP1 LP16) (22)
 (CA1 CA10) (22) - (LA1 LA10) (22)
 TAB (32) (CQ1P, CQ2P, CQ3P CQ4P)
 (LQ1 LQ2) (JQ3 JQ4) (CQ3 CQ4)
 3b TAB (Q1 Q3 Q2 Q4).
 가 4 2 (R1 R320) 160($p_2 \times n = 16 \times 10$) 가 , 8 (16)
 -가 (R1 R320) 16 ($p = p_2 = 16$), 2 ($q = q_2 = 2$)
 (22) 28 (n = 10)
 10
 6b (22) 2 (Q1 Q3) (50a)
 6b (Q2 Q4) (50b)
 (50a 50b) (A1 A10) 41.67 μ s
 (52) 가 (52) , (16)
 16 (P1 P16) 3.47 μ s
 , 2 (20)가 (14) 가
 20 ($q_2 \times n = 2 \times 10$) , 20
 16 ,
 2 (20) 20.0inch(50.8cm)/s
 (52) (20) 6.93×10^{-5} inch(1.76 x
 10^{-4} cm) 2 (50a 50b) (20)
 1 (46a 46d) {1/1200inch(0.00212cm)}
 , 2 (R1 R320) (20)가 2/1200{ 1/600}inch(
 0.00423cm) , 2
 가 (20)가 (14)
 , 2 가 1 , 2
 (P1 P16) 가

가

가 /

(57)

1.

q_1 p_2 가 ,

-가 ;

q_1 p_2 -가 , q_2 p_1 -가 가 ,

q_1 p_1 ,

q_2 p_2 ,

q_1 q_2 ,

p_1 p_1 ,

p_2 p_2 ,

p_2 p_1 q_2 ,

q_1 p_1 q_1 q_2 p_2 q_2 ,

;

2

가 1

2.

1 ,

n 3 가 ,

가 3 가 3 가 -
 가 3 , -가 3
 ,
 1 n 2 n , .

3.

2 ,
 -가 $q_1 \times n$ -가 , p_1
 -가 ;
 1 3 $q_1 \times n$
 -가 1 가 , 2 (enabled)

4.

2 ,
 -가 $q_2 \times n$ -가 , p_2
 -가 ;
 2 1 3 $q_2 \times n$
 가 , 2 -가

5.

2 ,
 가,
 1 q_1 1 ;
 2 p_2 2 ;
 3 n 3 , .

6.

5 ,
 , ,

1
;
2
;
1 2 (jumper) ;
n 3 n 3

7.

5 ,

1
;
2
;
2 1 ;
n 3 n 3

8.

6 ,

q_1 1 q_1
1 ;
 p_2 2 1
 p_1 2 ;
 p_1 2 p_2 2 2 p_1

9.

7 ,

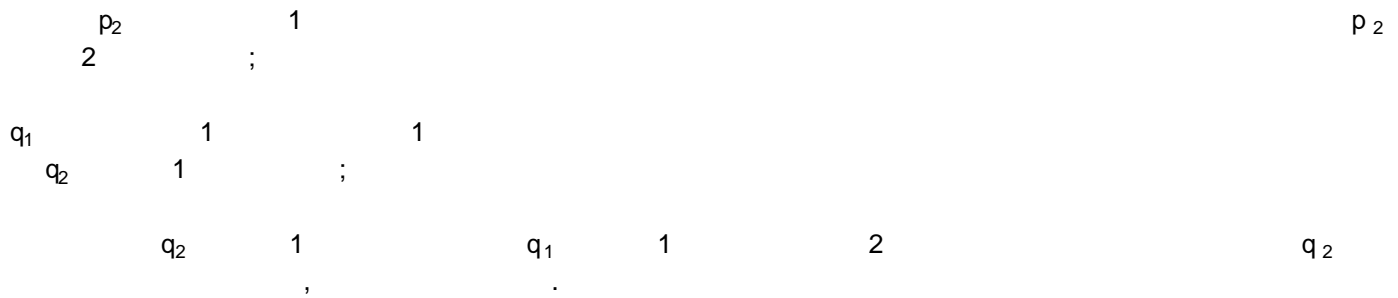

10.

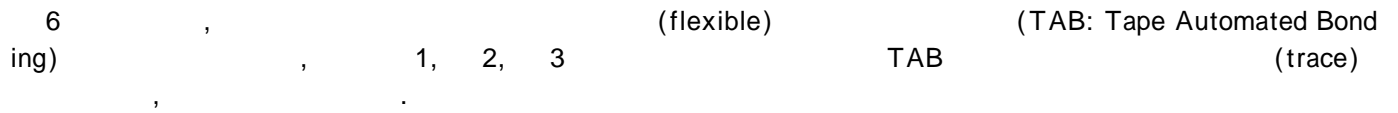

11.



12.

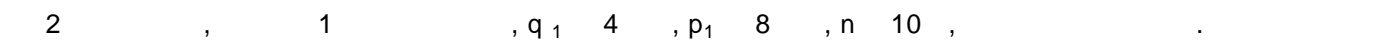

13.

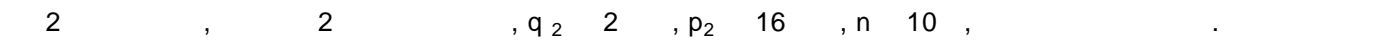

14.

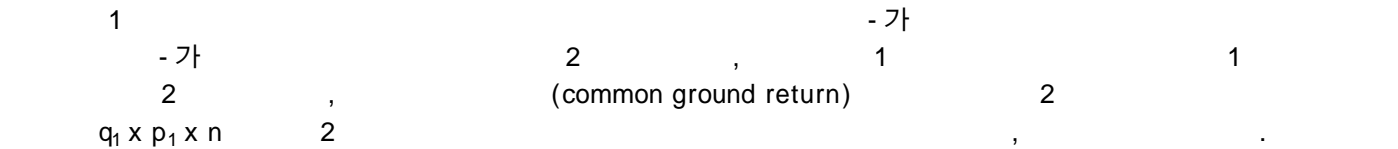

15.



1 1 , 1 1 , 1 1 ,

2 2 , 2 2 , 2 2 ,

16.

15 , 1 가 1 , 1 (high)
 , 2 가 , 3 가 1
 1 , -가 가

17.

6 ,
 ,

$p_1 \times n$ -가 1 , q_1 1
 , q_1 -가 ;

$q_2 \times n$ -가 2 , p_2 2
 , p_2 (primitive) ,

18.

15 , 1 p_2 2 1
 p_2 2 $q_1 \times n$ 가 , p_1 p_1 ,
 p_1 p_1 2 (jumper conductor) ,
 ,

19.

15 , 2 q_1 1 1
 q_1 1 $p_2 \times n$ 가 , q_2 q_2 , q_2
 -가 1 , q_2 ,

20.

q 1 p 2 ,

-가 ;

1 1 2 , 1 2 가
 -가 2 -가 ,
 1 2 가 ,

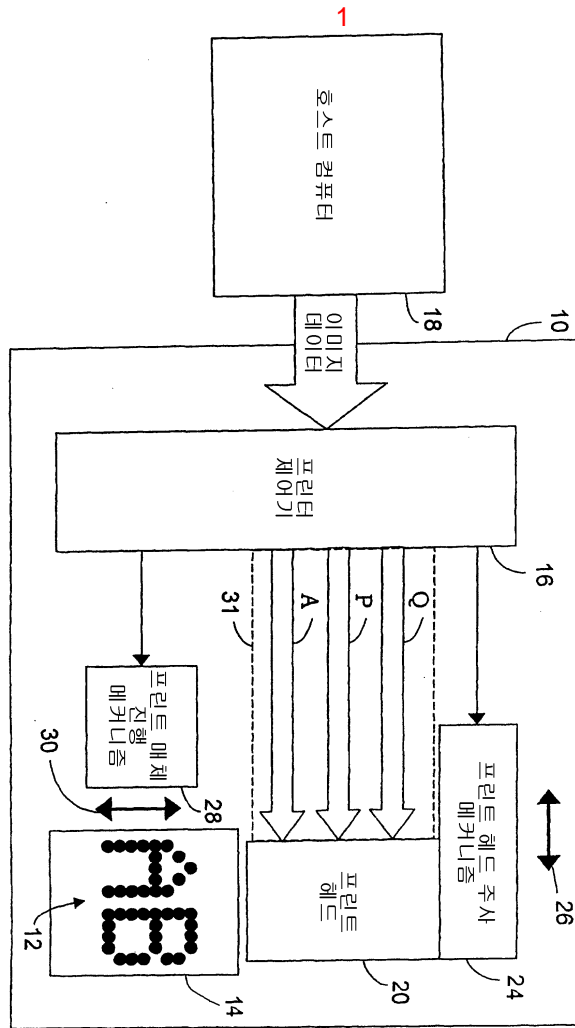

2

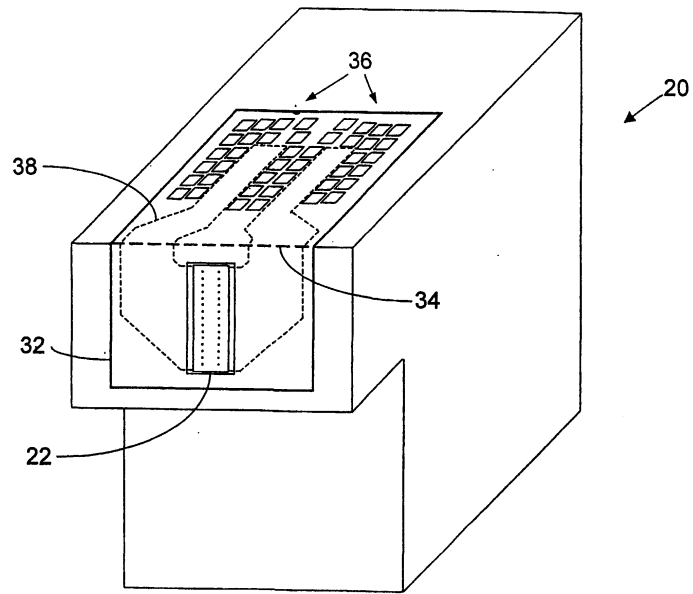

3a

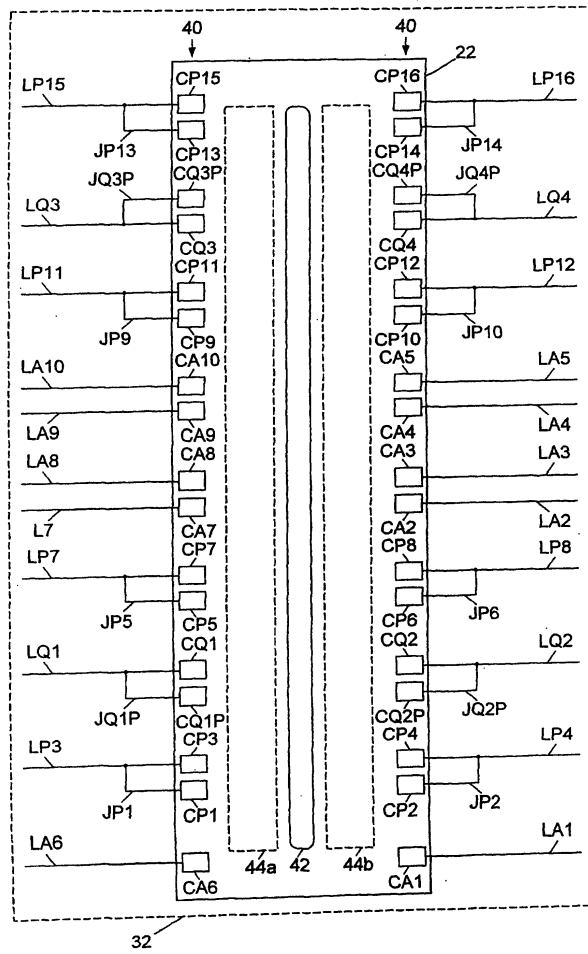

3b

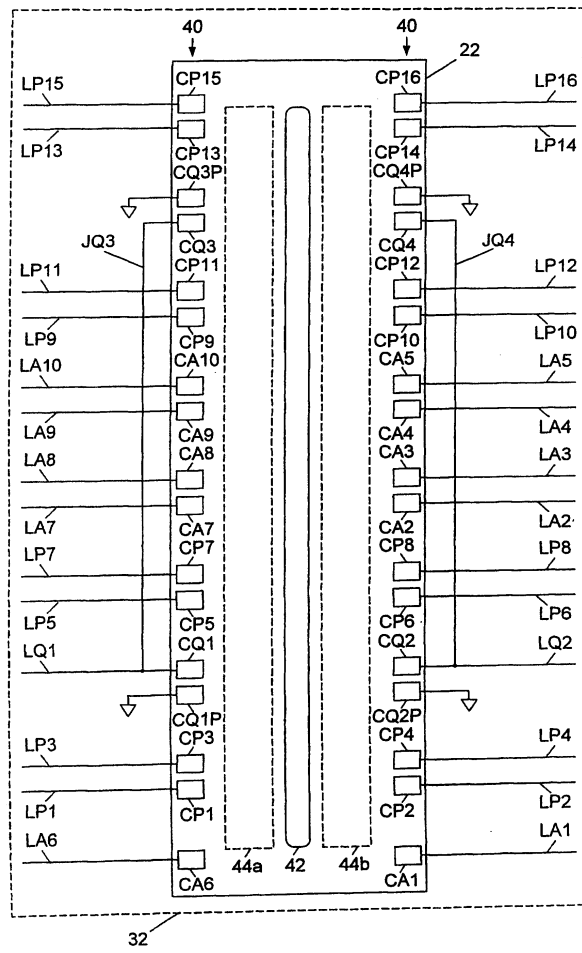

4a

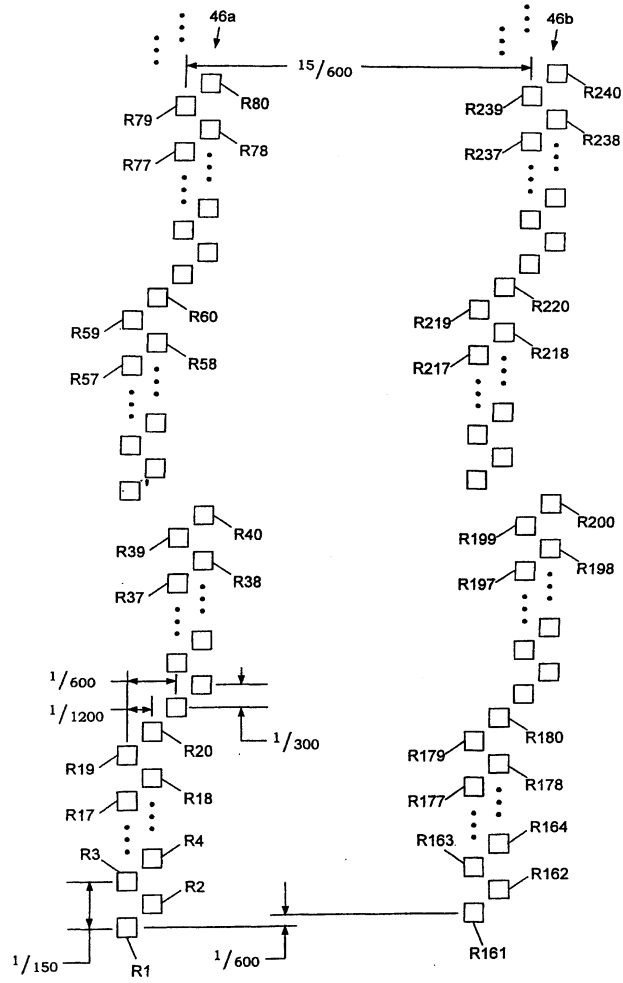

4b

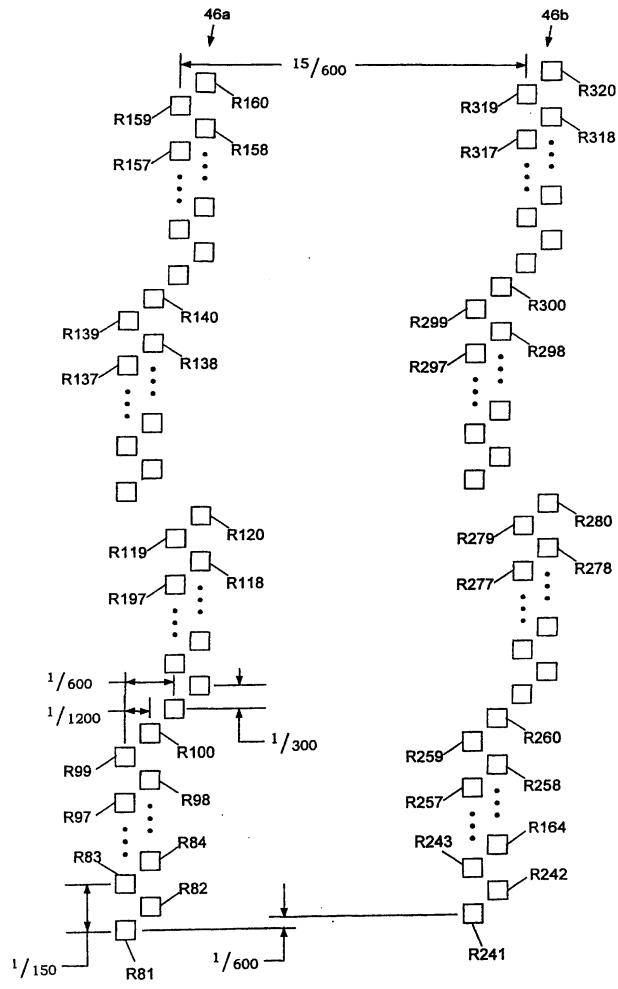

5a

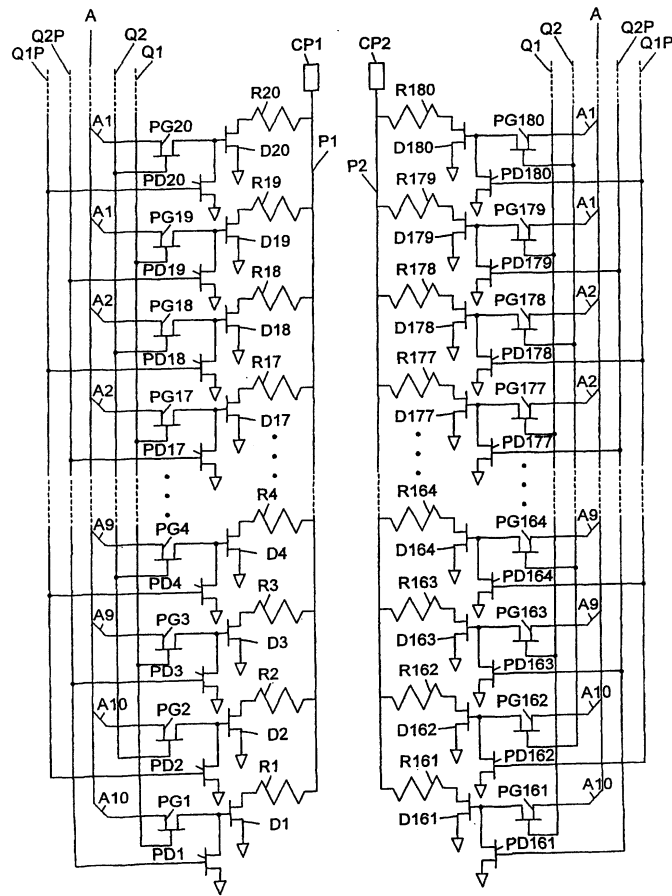

5b

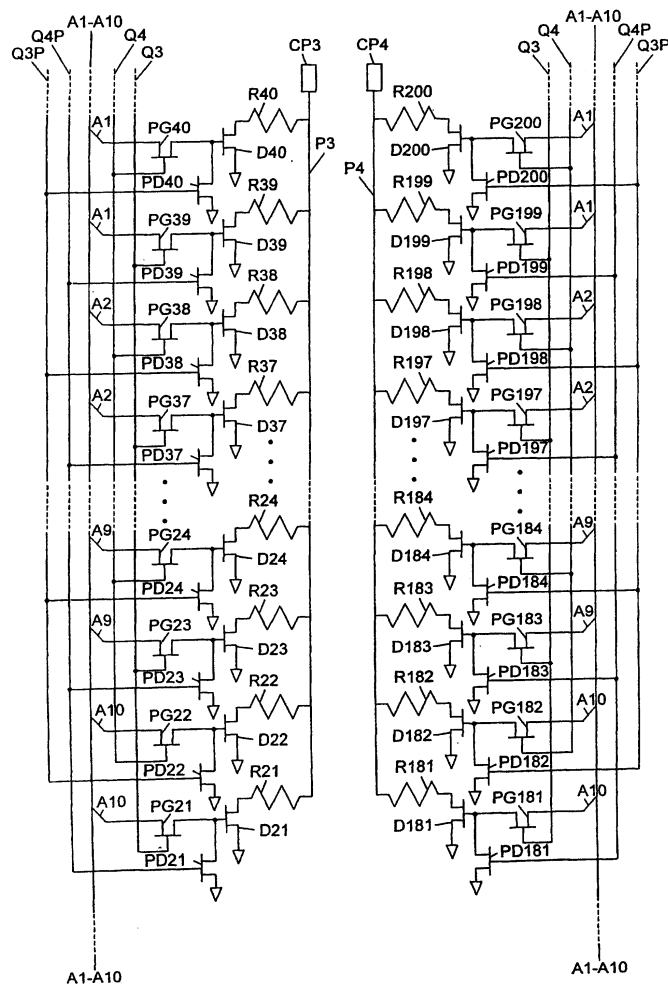

5c

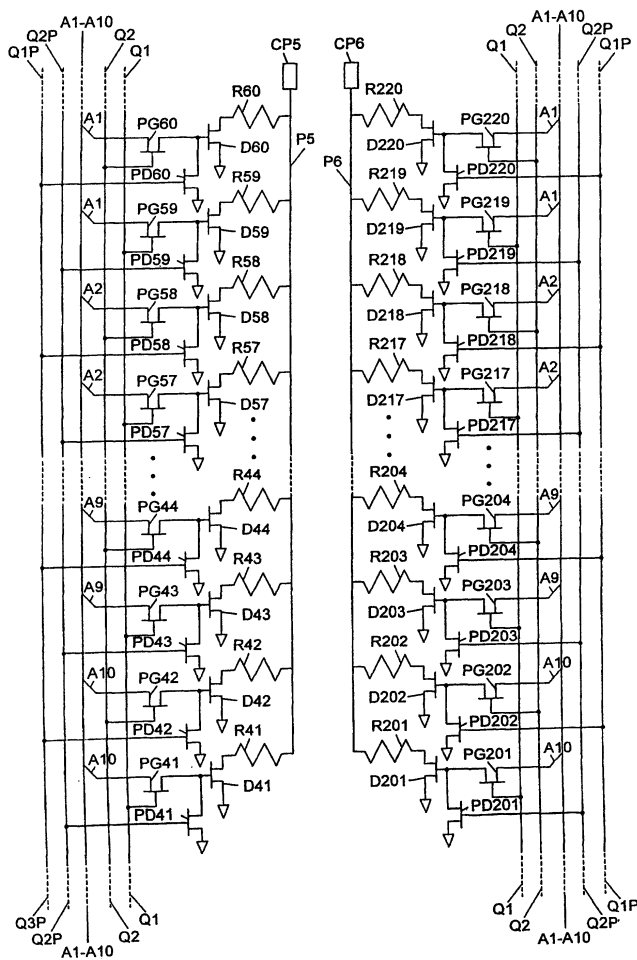

5d

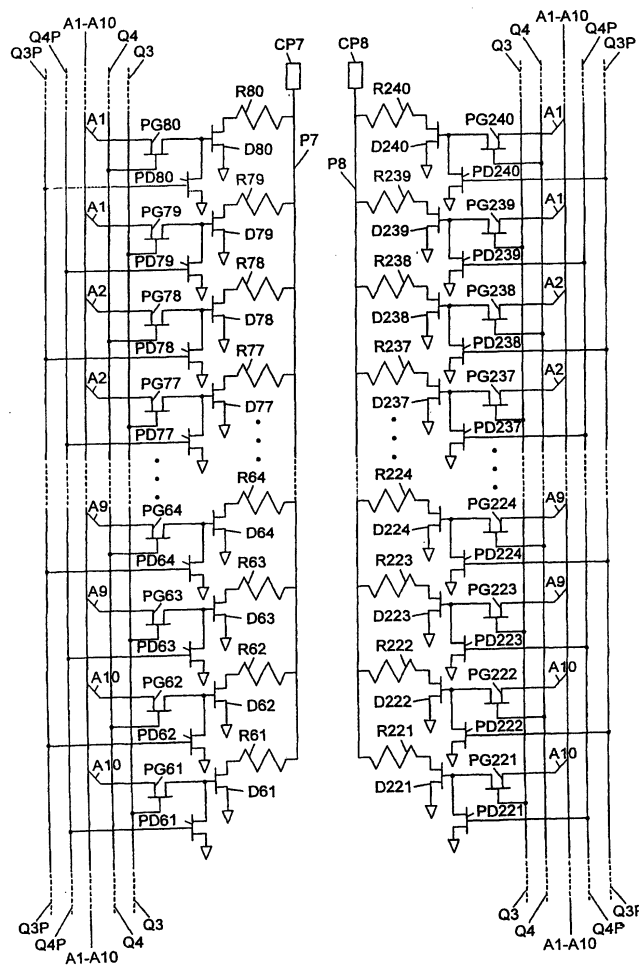

5e

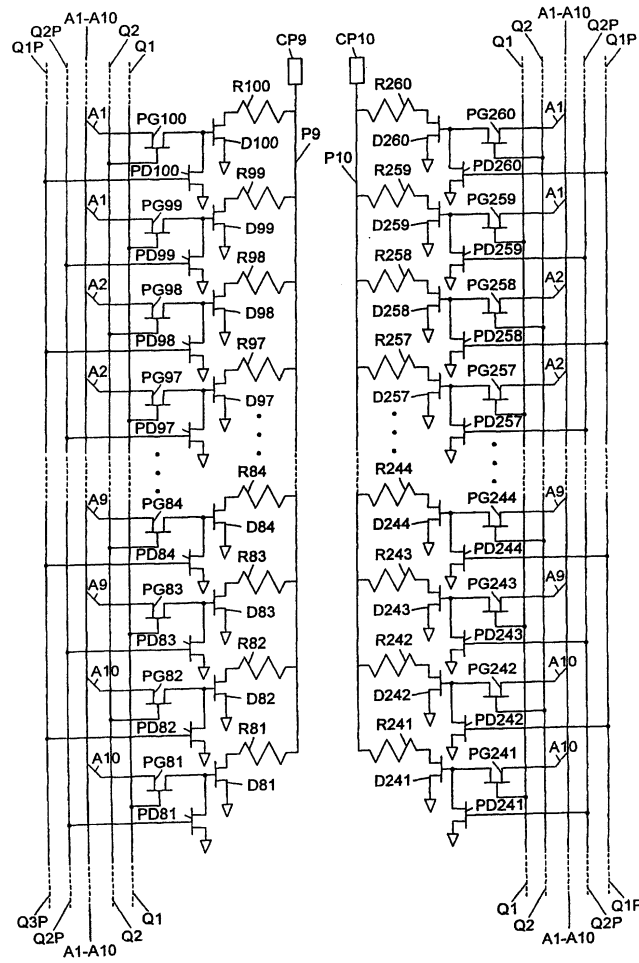

5g

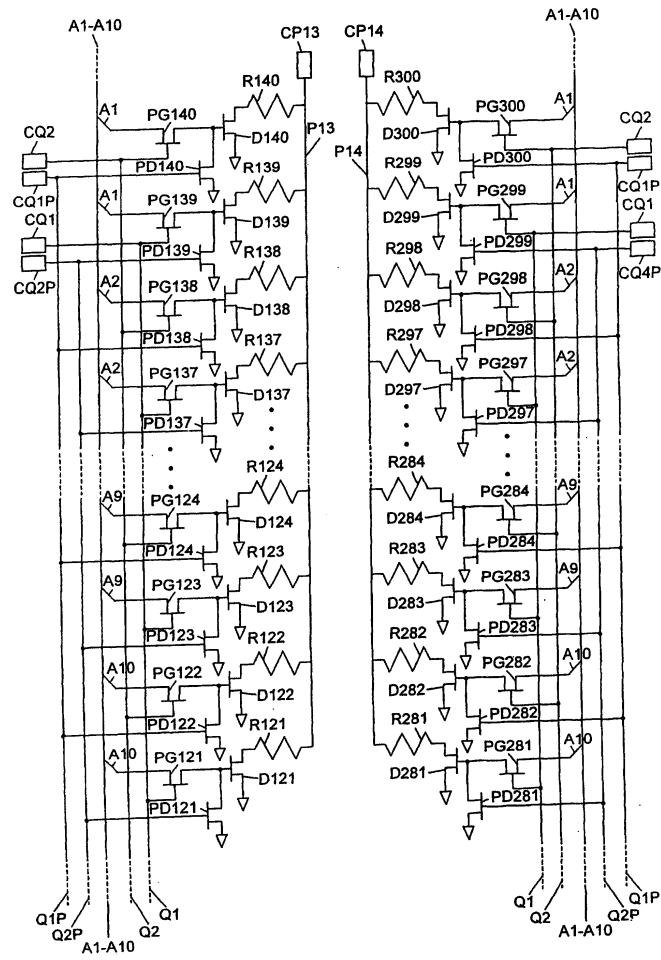

5h

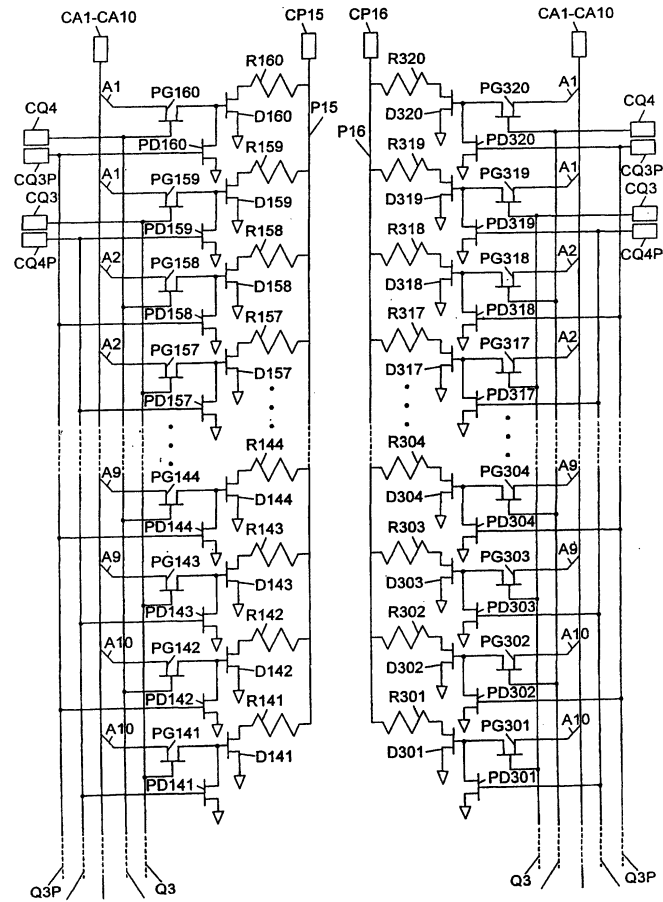

6a

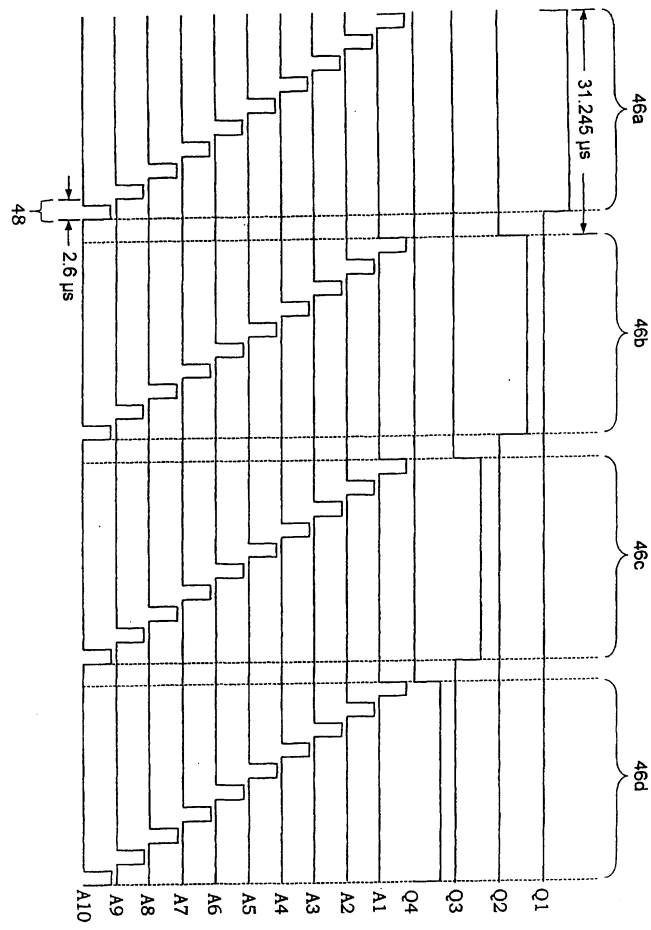

6b

