

(19) World Intellectual Property Organization
International Bureau



(43) International Publication Date
9 September 2011 (09.09.2011)

(10) International Publication Number
WO 2011/109626 A2

(51) International Patent Classification:
A46B 11/00 (2006.01)

(21) International Application Number:
PCT/US2011/027042

(22) International Filing Date:
3 March 2011 (03.03.2011)

(25) Filing Language: English

(26) Publication Language: English

(30) Priority Data:
12/717,755 4 March 2010 (04.03.2010) US

(71) Applicant (for all designated States except US): COLGATE-PALMOLIVE COMPANY [US/US]; 300 Park Avenue, New York, New York 10022 (US).

(72) Inventors; and
(75) Inventors/Applicants (for US only): JIMENEZ, Eduardo [US/US]; 21 Manor Drive, Manalapan, New Jersey 07726 (US). BOYD, Thomas [US/US]; 226 High Street, Metuchen, New Jersey 08840 (US). KENNEDY, Sharon [US/US]; 4213 Holbrook Road, Randallstown, Maryland 21133 (US). PATEL, Madhusudan [GB/US]; 197 Bambergh Court, Somerset, New Jersey 08873 (US). GATZEMEYER, John [US/US]; 85 Rohill Road, Hillsborough, New Jersey 08844 (US). MOSKOVICH, Robert [US/US]; 20 Jensen Street, New Brunswick, New Jersey 08816 (US). SORRENTINO, Alan [US/US]; 17 Adams Drive, Cranbury, New Jersey 08512 (US). ROONEY, Michael [US/US]; 63 Locust Avenue, Millburn, New Jersey 07041 (US).

[Continued on next page]

(54) Title: FLUID DISPENSING ORAL CARE IMPLEMENT

(57) Abstract: A fluid dispensing oral care implement with fluid delivery system. The implement includes a storage member containing a fluid. A channel formed of one or more wicking or capillary members extends through at least a portion of the oral care implement to deliver fluid(s) through one or more fluid outlets via capillary action. In one embodiment, the fluid outlet is comprised of a wicking or capillary material and is disposed in the head of the implement. In some embodiments, the implement may include a valve and a specially configured storage cap. A variety of fluids can be administered for therapeutic, hygienic, and/or other benefits, such as fresh breath, tooth whitening, tooth sensitivity, plaque and/or tartar control, or producing sensations of heat, cool, or tingling.

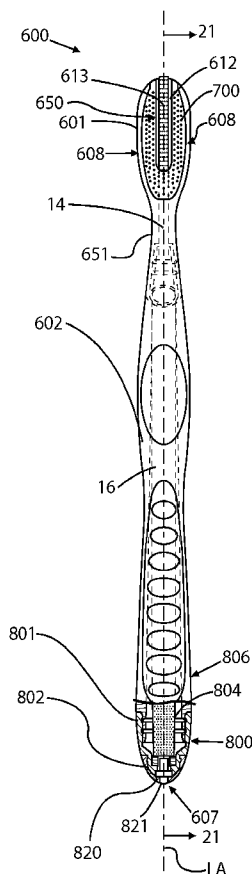

FIG. 20



WO 2011/109626 A2



(74) **Agent: CHUNG, Judy W.;** Colgate-Palmolive Company, Patent Department, 909 River Road, P.O. Box 1343, Piscataway, New Jersey 08855-1343 (US).

(81) **Designated States** (*unless otherwise indicated, for every kind of national protection available*): AE, AG, AL, AM, AO, AT, AU, AZ, BA, BB, BG, BH, BR, BW, BY, BZ, CA, CH, CL, CN, CO, CR, CU, CZ, DE, DK, DM, DO, DZ, EC, EE, EG, ES, FI, GB, GD, GE, GH, GM, GT, HN, HR, HU, ID, IL, IN, IS, JP, KE, KG, KM, KN, KP, KR, KZ, LA, LC, LK, LR, LS, LT, LU, LY, MA, MD, ME, MG, MK, MN, MW, MX, MY, MZ, NA, NG, NI, NO, NZ, OM, PE, PG, PH, PL, PT, RO, RS, RU, SC, SD, SE, SG, SK, SL, SM, ST, SV, SY, TH, TJ, TM, TN, TR, TT, TZ, UA, UG, US, UZ, VC, VN, ZA, ZM, ZW.

(84) **Designated States** (*unless otherwise indicated, for every kind of regional protection available*): ARIPO (BW, GH, GM, KE, LR, LS, MW, MZ, NA, SD, SL, SZ, TZ, UG, ZM, ZW), Eurasian (AM, AZ, BY, KG, KZ, MD, RU, TJ, TM), European (AL, AT, BE, BG, CH, CY, CZ, DE, DK, EE, ES, FI, FR, GB, GR, HR, HU, IE, IS, IT, LT, LU, LV, MC, MK, MT, NL, NO, PL, PT, RO, RS, SE, SI, SK, SM, TR), OAPI (BF, BJ, CF, CG, CI, CM, GA, GN, GQ, GW, ML, MR, NE, SN, TD, TG).

Published:

— *without international search report and to be republished upon receipt of that report (Rule 48.2(g))*

FLUID DISPENSING ORAL CARE IMPLEMENT

FIELD

[0001] The present invention is directed to an oral care implement including a capillary delivery system for dispensing a fluid.

BACKGROUND

[0002] Oral care implements, particularly toothbrushes, are typically used by applying toothpaste to a bristle section followed by brushing regions of the oral cavity, e.g., the teeth, tongue, and/or gums. Some toothbrushes have been equipped with fluid reservoirs and systems for delivering auxiliary oral care agents, such as whitening agents, breath freshening agents, and others. There is a continuing need, however, for improved oral care implements for dispensing auxiliary oral care agents from the implement.

BRIEF SUMMARY

[0003] The present invention pertains to an oral care implement having a capillary delivery system. Optionally, the oral care implement has a head containing tooth cleaning elements on a first surface thereof.

[0004] In one embodiment, an oral care implement includes a reservoir containing at least one fluid. A variety of fluids can be administered for therapeutic, hygienic, and/or other benefits, such as fresh breath, tooth whitening, or producing sensations of heat, cool, or tingling.

[0005] In another embodiment, an oral care implement includes a channel extending through at least a portion of the implement to deliver the fluid to one or more outlets. In one embodiment, an outlet is located on a second surface of the head generally opposite the first surface that contains the tooth cleaning elements.

[0006] In yet another embodiment, an oral care implement has a head containing tooth cleaning elements, a reservoir for storing a fluid and an overflow chamber. The reservoir and overflow chamber may be separated by a partition. A capillary channel constructed from a fibrous material, ceramic, porous plastic, or combination thereof extends through at least a portion of the implement to deliver the fluid to one or more outlets.

[0007] In another embodiment, an oral care implement has a head containing tooth cleaning elements, a reservoir containing at least one fluid, a capillary channel extending through at least a portion of the implement to deliver the fluid to one or more outlets, and

a motion-producing device. When activated, the motion-producing device vibrates the implement or a portion thereof, such as the head portion. The vibration enhances the function of the tooth cleaning elements and also promotes delivery of the fluid through the capillary channel, which together provides an enhanced sensorial experience for the user as well as enhanced cleaning.

[0008] According to another aspect of the invention, an oral care implement is provided including a head including at least one tooth cleaning element, a storage member for storing a fluid, at least one fluid outlet disposed on the head, and a channel fluidly coupling the storage member to the outlet. In some embodiments, the channel is a first wicking member formed of a wicking material and defining a first flow section, the fluid outlet is a second wicking member formed of a wicking material and defining a second flow section. The second wicking member is fluidly coupled to the first wicking member and the fluid flows via capillary action through the first wicking member at a flow rate that is different than in the second wicking member. In some embodiments, the first and second wicking members are made of different materials having different capillarities.

[0009] According to another aspect of the invention, an oral care implement is provided that includes a head including at least one tooth cleaning element, a storage member for storing a fluid, at least one fluid outlet disposed on the head, and a channel fluidly coupling the reservoir to the outlet. A flow restrictor is positioned between the channel and the storage member so that fluid flows at a reduced rate of flow that is smaller than a rate of flow through the storage member. In one embodiment, the flow restrictor is a reduced cross-sectional flow area disposed between the channel and the storage member that are operative to reduce the flow therebetween. In some embodiments, a flow restrictor may be a notched area or lateral offset formed between the channel and the outlet. The channel and fluid outlet may be a unitary member or separate members fluidly coupled together.

[0010] According to another embodiment, a fluid dispensing toothbrush is provided and includes a head including a plurality of tooth cleaning elements and a tissue cleaner, a handle coupled to the head for grasping, a storage member disposed in the handle for storing a fluid, at least one fluid outlet formed of a wicking material and disposed in the head, and a channel fluidly coupling the storage member to the outlet. The channel is preferably formed of a wicking material. The fluid flows via capillary action through the channel to the outlet from which the fluid is dispensed.

[0011] According to another aspect of the invention, a method for dispensing a fluid from an oral care implement, such as without limitation a toothbrush, is provided. In one embodiment, the method includes the steps of: filling at least partially a storage member

in a handle of the oral care implement, filling a fluid outlet disposed in an oral care implement with the fluid, the outlet being formed of a wicking material; contacting an oral surface of a user with the fluid outlet; wicking the fluid through the capillary outlet; and dispensing the fluid onto the oral surface from the capillary outlet.

[0012] According to other exemplary embodiments of the invention, a fluid dispensing oral care implement is provided that includes a handle for grasping, a head including at least one tooth cleaning element, a storage member for storing an fluid containing an oral care agent, at least one fluid outlet disposed in the head, and a channel formed of a wicking material and fluidly coupling the storage member to the outlet. The capillary channel includes a means for producing a first fluid flow rate of fluid.

[0013] According to another exemplary embodiment of the invention, a fluid dispensing toothbrush is provided including a head including a plurality of tooth cleaning elements and a tissue cleaner, a handle coupled to the head for grasping, a storage member disposed in the handle for storing a fluid, at least one fluid outlet formed of a wicking material and disposed in the head, and a channel fluidly coupling the storage member to the outlet. The channel is formed of a wicking material and the fluid flows via capillary action through the channel to the outlet from which the fluid is dispensed. The toothbrush further includes a check valve disposed in the handle and in fluid communication with the handle and a vent opening disposed in the handle. The check valve is operative to introduce external air into the handle via the vent opening to maintain flow and prevent vapor lock in the reservoir when the fluid is drawn out fo the storage member through the channel. In one embodiment, the toothbrush further comprises an end cap disposed on a proximal end of the toothbrush and the valve is disposed and seated in the end cap. In another embodiment, a vent opening is disposed in the end cap.

[0014] According to another exemplary embodiment of the invention, a fluid dispensing toothbrush is provided including a handle for grasping, a head including a plurality of tooth cleaning elements, a storage member for storing a fluid, at least one fluid outlet disposed in the head for dispensing the fluid and having a shape, a channel formed of a wicking material and fluidly coupling the storage member to the outlet, and a storage cap removably attachable to the head of the toothbrush. The cap includes a sealing socket configured to substantially conform to the shape of the fluid outlet so that when the storage cap is attached to the toothbrush head, the socket is operative to at least partially seal the fluid outlet to minimize evaporative loss of the fluid.

[0015] According to other exemplary embodiments of the invention, a method for dispensing a fluid from an oral care implement is provided. The method includes: filling

at least partially a fluid outlet disposed in an oral care implement with an fluid, the outlet being formed of a wicking material; contacting an oral surface of a user with the fluid outlet; wicking the fluid through the fluid outlet; dispensing the fluid onto the oral surface at a first flow rate from the fluid outlet; and refilling the fluid outlet from a channel fluidly coupled between the capillary outlet and a storage member containing the fluid, wherein the fluid outlet is refilled with fluid from the channel at a second flow rate that is less than the first flow rate of the fluid dispensing from the fluid outlet.

BRIEF DESCRIPTION OF THE DRAWINGS

[0016] The features and advantages of the invention will be apparent from the following more detailed description of certain embodiments of the invention and as illustrated in the accompanying drawings in which:

[0017] FIG. 1 is a schematic illustration of a oral care implement according to one embodiment of the invention;

[0018] FIG. 2 is a front perspective view of the head of the oral care implement shown in FIG. 1;

[0019] FIG. 3 is a rear perspective view of the head of the oral care implement shown in FIG. 1;

[0020] FIGS. 4-7 show examples of capillary configurations that can be used with the oral care implement;

[0021] FIG. 8 is an exploded assembly perspective view of an oral care implement according to one or more aspects of an illustrative embodiment;

[0022] FIG. 9 is an enlarged perspective view of a head of an oral care implement of FIG. 8;

[0023] FIG. 10 is a plan view of the oral care implement of FIG. 8 illustrating a tongue cleaning feature;

[0024] FIG. 11 is a partial section view of a head of the oral care implement of FIG. 8 taken along line 4-4 of FIG. 10;

[0025] FIG. 12 is a plan view of the oral care implement of FIG. 8 illustrating at least one tooth cleaning configuration;

[0026] FIG. 13 is a perspective of the view of the oral care implement illustrating example tooth cleaning elements;

[0027] FIG. 14 is a schematic diagram of a multi-stage capillary fluid dispensing system according to one exemplary embodiment of the invention;

[0028] FIG. 15 is a schematic diagram of a multi-stage capillary fluid dispensing system with one embodiment of a flow restrictor;

[0029] FIG. 16 is a schematic diagram of a multi-stage capillary fluid dispensing system with another embodiment of a flow restrictor;

[0030] FIG. 17 is an enlarged side cross sectional view of a second embodiment of a oral care implement head including a capillary delivery system incorporated into a tissue cleaner;

[0031] FIG. 18 is a rear perspective view of the head of FIG. 17;

[0032] FIG. 19 is a cross-sectional perspective view of a capillary channel comprising concentrically aligned capillary or wicking members;

[0033] FIG. 20 is a plan view of a fluid dispensing oral care implement according to one exemplary embodiment;

[0034] FIG. 21 is a side cross-sectional view thereof;

[0035] FIG. 22 is an exploded view of the fluid dispensing oral care implement of FIG. 20.

[0036] FIG. 23 is an enlarged cross-sectional view of an end portion of the oral care implement of FIG. 21;

[0037] FIG. 24 is a plan view of an embodiment of a storage cap mounted on the head of and useable with the oral care implement of FIG. 20;

[0038] FIG. 25 is a side view of the storage cap on the oral care implement of FIG. 23;

[0039] FIG. 26 is a perspective view of the storage cap alone of FIG. 23;

[0040] FIG. 27 is a plan view of the storage cap of FIG. 26; and

[0041] FIG. 27 is a side view of the storage cap of FIG. 26.

DETAILED DESCRIPTION OF THE PREFERRED EMBODIMENTS

[0042] FIG. 1 schematically illustrates an oral care implement having a handle 1 and a head 2 containing one or more tooth cleaning elements, such as bristles 6 and/or elastomeric cleaning elements 7. A reservoir 11 is provided for storing a fluid. The fluid is most often in the form of a liquid, but can be in other forms, e.g., semi-solid, paste, gel, etc. so long as it is capable of flowing. In some embodiments the fluid is or contains an oral care agent, but the invention is not so limited. The reservoir 11 can include a liquid storage tank 11a in fluid communication with a delivery section 11b. A channel 14 generally extends in the longitudinal direction of the toothbrush for delivering the fluid from the reservoir 11 to at least one outlet 15.

[0043] In one aspect, the outlet 15 can be located on a surface of the head 2 generally opposite the surface that contains the tooth cleaning elements 6 and 7. In another aspect, the outlet 15 can be located within the tooth cleaning elements 6, 7. Optionally, a

plurality of outlets may be provided on both the surface of the head that contains the tooth cleaning elements as well as the opposite the surface of the head, e.g., for delivering the same fluid from a common supply or different fluids from separate supplies.

[0044] The channel 14 uses capillary action to draw liquid from the reservoir 11 to the outlet 15. The outlet 15 can be configured as a non-woven pad, membrane or other structure, such as an orifice, that allows passage of the fluid. Examples of materials that can be used for the outlet include porous plastics and other porous materials, such as those described below with reference to the channel 14.

[0045] The channel 14 generally has a capillary structure and usually is a porous material. Examples of suitable materials include fibrous materials, ceramics, and porous plastics such as those available from Porex Technologies, Atlanta, Georgia. One example of a fibrous material is an acrylic material identified as type number C10010, available from Teibow Hanbai Co., Ltd., Tokyo, Japan. A mixture of porous and/or fibrous materials may be provided which have a distribution of larger and smaller capillaries. The channel can be formed from a number of small capillaries that are connected to one another, or as a larger single capillary tube.

[0046] The reservoir 11 may be formed from any suitable material and may include reticulated foam, which may range from hydrophilic to hydrophobic. Hydrophobic foams may be used with non-water based liquids. An example of a reticulated foam is Bulpren S90, manufactured by Recticel (Wetteren, Belgium). Bulpren S90 is an open cell polyurethane foam based on polyester which averages 90 pores per inch. Hydrophilic foams may be used with water based liquids. Other examples of materials that can be used for the reservoir 11 include ceramics and porous plastics. In a preferred embodiment, the reservoir may be a commercially available bonded fiber component from Filtrona or Porex, such as without limitation polypropylene, polyethylene, or copolymers of such polymers in varying ranges of hydrophobicity depending on the composition selected.

[0047] Non-limiting examples of capillary configurations that can be used are shown in FIGS. 4-7. The capillary devices 10 generally have a housing 20 that includes a reservoir 11 for storing an fluid 13 and an overflow chamber 25. The reservoir 11 and overflow chamber 25 may be separated by a partition 21, for example, or otherwise separated such as described below with reference to FIG. 7. The reservoir 11 may be an integral part of housing 20 or a separate element connected to the housing. An inlet 22 allows air to flow freely into and out of overflow chamber 25.

[0048] Partition 21 may include an opening 12 which is closed by the channel 14. The channel 14 generally extends from the opening 12 to the outlet 15 and is in direct contact

with a capillary storage 16. The average capillarity of the capillary storage 16 is generally smaller than the average capillarity of channel 14. Although the capillary storage is arranged about the periphery of capillary channel 14, it does not necessarily extend all the way around the channel. Strict separation of capillary storage 16 and channel 14 is not necessary.

[0049] The capillary channel 14 can be press-fit into an opening in the handle 1 or, alternatively, the handle 1 can be overmolded around the capillary channel 14. In a preferred method of manufacturing, channel 14 is formed separately and inserted into handle 1. The capillary channel 14 generally provides the only path by which air can enter the otherwise closed reservoir 11. The finer capillaries of channel 14 transfer fluid to the outlet 15. The larger capillaries allow air to enter the reservoir 11. In general, air can enter through at least the largest capillary in the channel 14.

[0050] With reference to FIG. 5, by way of example, when air expansion takes place within the reservoir 11, a portion of the fluid 13 in the reservoir 11 will be transferred through an opening 12 and channel 14 into the normally fluid-free portions of capillary storage 16. In other words, capillary storage 16 receives excess fluid and prevents uncontrolled leakage of the fluid from the outlet 15, or other portions of the implement. The excess fluid in capillary storage 16 will return to the reservoir 11 through channel 14 when the pressure in the reservoir 11 subsides. This process is repeated whenever temperature fluctuations, for example, cause air volume fluctuations within the reservoir 11. As the fluid stored in capillary storage 16 is always returned to reservoir 11, the capillary storage will not already be filled to capacity when there is an air expansion. Also, even though channel 14 is continuously wetted with fluid, at least in the area of opening 12, air cannot interrupt the return of the fluid 13 to the reservoir 11 as long as there is fluid in the capillaries of the storage 16 which are larger than the largest pore in the channel 14.

[0051] Although the outlet 15 is illustrated in FIGS. 1, 3, 5, and 6 as a separate element from the channel 14, it should be recognized that the outlet 15 may alternatively be integral with the channel 14, as schematically shown in FIGS. 4 and 7. When the outlet 15 is formed from a porous material, its pores generally should be smaller than those of the channel 14 to ensure that the fluid in the channel 14 will flow toward the outlet 15 during dispensing. With reference to FIGS. 4 and 6, channel 14 may be configured so that it extends into area 19 near the reservoir base 18. In this type of configuration, the capillary storage and the capillary channel 14 usually are enclosed by a tube 24. The tube 24 provides additional protection against unwanted leakage.

[0052] In the configuration shown in FIG. 4, capillary storage 16 and capillary channel 14 are separate structural elements and the channel 14 extends into base area 19. In the configuration shown in FIG. 6, a mixture of porous materials having the requisite combination of capillary sizes form a unitary capillary storage 16 and channel 14.

[0053] In the configuration shown in FIG. 5, channel 14 and capillary storage 16 define a unitary structural element similar to that shown in FIG. 6. The rear portion 140 of the integral channel and capillary storage is tapered so that it may be received in opening 12. To ensure that there is a sufficient amount of fine, fluid transferring capillaries in the opening 12, this portion of the combined channel/storage may be pinched together at the opening in a defined manner. The rear portion 140 may also be provided as a separate element that is connected to the capillary storage.

[0054] As shown, for example, in FIG. 7, capillary channel 14' may be configured so that it includes a radially extending portion that separates the reservoir 11 from the overflow chamber 25. The channel 14' and radially extending portion fill the opening between the reservoir 11 and the overflow chamber 25. The pores in the radially extending portion may be substantially similar to those in the channel 14' and allow air to pass, but block the flow of fluid. As a result, the radially extending portion may be used to regulate the flow of air into the channel 14'.

[0055] In another aspect, a vibratory device can be provided to vibrate the toothbrush or a portion thereof, such as the head 2 or a portion thereof. The vibration-producing device can be used to vibrate tooth cleaning elements 6 and 7 and/or soft tissue cleaning elements while, at the same time, promote delivery of the fluid(s) through the capillary channel 14 to provide an enhanced cleaning action.

[0056] A wide variety of vibratory devices can be used to produce vibrations over a wide range of frequencies to meet the needs of a particular application. Various types of vibratory devices are commercially available, such as transducers. One example of a vibratory device provides frequencies in the range of about 100 to 350 kHz. The vibration frequencies may be of different waveforms, including sinusoid, square, sawtooth and the like. Nevertheless, other values and waveforms are possible. A vibratory device may be located in head of the toothbrush or neck thereof. When activated, vibratory device is powered by battery (and controlled by electronics on circuit board or switching system) so as to induce vibrations in head of the toothbrush and thereby enhances teeth-cleaning action imparted by the tooth cleaning elements. In alternate embodiments, a vibratory device may include a micro motor attached to a shaft, with the shaft coupled to an eccentric rotating about an axis parallel to the longitudinal

axis of the toothbrush. In still other embodiments, a vibratory-producing device includes an eccentric that is driven by a micro motor in a translatory manner.

[0057] A switch, such as a button, toggle switch, rotating dial, or the like, can be provided for activating the vibratory device. A vibratory device often has a power source, such as a battery. Activating the switch can cause the vibration-producing device to operate for a user-defined interval (e.g., during the time that a button is depressed or a switch is in an engaged position), or alternatively can activate a timing circuit that causes the vibratory device to operate for a predetermined interval. If a timing circuit is used, the associated interval either may be preset or may be adjustable, e.g., by a user-activated rotating dial.

[0058] Additional embodiments of the invention include configurations of vibratory device(s), bristles (or other tooth cleaning elements) and other components as described in U.S. Patent Application Ser. No. 10/768,363 (filed January 30, 2004 and titled "Toothbrush with Enhanced Cleaning Effects"), published as U.S. Pat. Pub. No. 20050091769A1, incorporated by reference herein. For example, the neck portion of the toothbrush can be provided with neck-part zones made of an elastically relatively compliant material so as to increase the elasticity of the neck part. This would permit the head, during use of the toothbrush, to be forced back resiliently in the case of forces acting in the direction of the brushing surface. Optionally, the neck-part zones could be designed as notches which extend over part of the neck circumference and are filled with elastically compliant material (e.g. with thermoplastic elastomer).

[0059] The outlet 15 can be incorporated into an elastomeric material to provide a tissue cleaner, which can be used, for example, for cleaning the tongue, cheeks, lips, and/or gums. A tissue cleaner may employ a variety of suitable biocompatible resilient materials, such as elastomeric materials. To provide optimum comfort as well as cleaning benefits, an elastomeric material usually has a hardness property in the range of A8 to A25 Shore hardness, such as styrene-ethylene/butylene-styrene block copolymer (SEBS), available from GLS Corporation.

[0060] A tissue cleaner can be configured with a multiplicity of tissue engaging elements, which can be formed as nubs. As used herein, a "nub" is generally meant to include a column-like protrusion (without limitation to the cross-sectional shape of the protrusion) which is upstanding from a base surface. In general, the nub can have a height that is greater than the width at the base of the nub as measured in the longest direction. Nubs also can include projections wherein the widths and heights are roughly the same or wherein the heights are somewhat smaller than the base widths.

[0061] Such tissue engaging elements can help reduce a major source of bad breath and improve hygiene. Nubs enable removal of microflora and other debris from the tongue and other soft tissue surfaces within the mouth. The tongue, in particular, is prone to develop bacterial coatings that are known to harbor organisms and debris that can contribute to bad breath. This microflora can be found in the recesses between the papillae on most of the tongue's upper surface as well as along other soft tissue surfaces in the mouth. When engaged or otherwise pulled against a tongue surface, for example, the nubs of elastomeric tissue cleaner can provide for gentle engagement with the soft tissue while reaching downward into the recesses of adjacent papillae of the tongue. The elastomeric construction of a tissue cleaner also enables the base surface to follow the natural contours of the oral tissue surfaces, such as the tongue, cheeks, lips, and gums of a user. In addition, the soft nubs are able to flex as needed to traverse and clean the soft tissue surfaces in the mouth along which it is moved.

[0062] The nubs often are conically shaped, such as in the shape of a true cone, frusto-conically shaped elements, and other shapes that taper to a narrow end and thereby resemble a cone irrespective of whether they are uniform, continuous in their taper, or have rounded cross-sections. The smaller width or diameter of the tip portion in conjunction with the length of the conically shaped nub enable the nubs to sweep into the recesses of the tongue and other surfaces to clean the microbial deposits and other debris from the soft tissue surfaces. The nubs also are able to flex and bend from their respective vertical axes as lateral pressure is applied during use. This flexing enhances the comfort and cleaning of the soft tissue surfaces. Alternatively, tissue cleaning elements may have other shapes.

[0063] The fluid can be incorporated into a sealed reservoir 11 during manufacture of the toothbrush, in which case the toothbrush can be disposed of after the supply of the fluid is exhausted. Alternatively, the reservoir 11 can be refillable through an inlet (not shown), and/or can be replaceable, e.g., by inserting a replaceable cartridge into a recess in the toothbrush. The cartridge can be spring-loaded to stay in place after insertion, and can have a seal to prevent unwanted leakage of the fluid.

[0064] As illustrated in FIG. 1, the toothbrush can comprise a brush section A and a reservoir section B that are joined to each other, e.g., by threaded engagement, snap-fitting, or the like. The reservoir section B can be disposable, refillable, and/or interchangeable with other reservoir sections B containing different fluids, for example.

[0065] Optionally, a user-activated switch, such as a dial (not shown), can have multiple settings for selecting one or more of several fluids. For example, the dial can have a first setting for oxidizer/whitener treatment, a second setting for breath freshener treatment,

and a third setting for antimicrobial treatment. The toothbrush can be supplied in the form of a kit including a toothbrush or a brush section A thereof, and one or more cartridges or reservoir sections B containing fluid(s). Multiple cartridges can be provided, for example, for supplying different fluids or a replacement supply of the same fluid.

[0066] In FIG. 1, a toothbrush is shown schematically having a head 2, bristles 6, and a handle 1. It should be understood that any bristle configuration and any handle configuration can be used, and the present invention should not be regarded as being limited to any particular configuration.

[0067] The toothbrush can be used by brushing the teeth or gums using bristles 6 and/or other tooth cleaning elements and/or by massaging the tongue, gums, or other regions of the oral cavity with a tissue cleaner. The fluid can be administered through one or more outlets present in or near the tooth cleaning elements and/or within the tissue cleaner and/or on other locations on the toothbrush. Depending on the type of fluid used and the location of the outlet(s), the fluid can be administered before, during, or after brushing.

[0068] Non-limiting examples of fluids or oral care agents which can be used include antibacterial agents, whitening agents, anti-sensitivity agents, anti-inflammatory agents, anti-attachment agents, plaque indicator agents, flavorants, sensates, and colorants. Examples of these agents include metal ion agents (e.g., stannous ion agents, copper ion agents, zinc ion agents, silver ion agents) triclosan; triclosan monophosphate, chlorhexidine, alexidine, hexetidine, sanguinarine, benzalkonium chloride, salicylanilide, domiphen bromide, cetylpyridinium chloride, tetradecylpyridinium chloride, N-tetradecyl-4-ethylpyridinium chloride (TDEPC), octenidine, delmopinol, octapinol, nisin, essential oils, furanones, bacteriocins, flavans, flavinoids, folic acids, vitamins, hydrogen peroxide, urea peroxide, sodium percarbonate, PVP-H₂O₂, polymer-bound peroxides, potassium nitrates, occluding agents, bioactive glass, arginine salts, arginine bicarbonate, bacalin, polyphenols, ethyl pyruvate, guanidinoethyl disulfide, tartar control agents, anti-stain ingredients, phosphate salts, polyvinylphosphonic acid, PVM/MA copolymers; enzymes, glucose oxidase, papain, ficin, ethyl lauroyl arginate, menthol, carvone, and anethole, various flavoring aldehydes, esters, and alcohols, magnolia bark extract, spearmint oils, peppermint oil, wintergreen oil, sassafras oil, clove oil, sage oil, eucalyptus oil, marjoram oil, cinnamon oil, lemon oil, lime oil, grapefruit oil, and/or orange oil.

[0069] The fluid or oral care agent and/or its medium can be selected to complement a toothpaste formula, such as by coordinating flavors, colors, aesthetics, or active

ingredients. A flavor can be administered to create a gradual flavor change during brushing, which presently is not possible using toothpaste alone.

[0070] The fluid may be compatible with toothpaste, or may be unstable and/or reactive with typical toothpaste ingredients. The fluid also may be a tooth cleaning agent to boost the overall efficacy of brushing.

[0071] The oral care agent can be provided in any suitable vehicle, such as in aqueous solution or in the form of gel or paste. Non-limiting examples of vehicles include water, monohydric alcohols such as ethanol, poly(ethylene oxides) such as polyethylene glycols such as PEG 2M, 5M, 7M, 14M, 23M, 45M, and 90M available from Union Carbide, carboxymethylene polymers such as Carbopol[®] 934 and 974 available from B.F. Goodrich, and combinations thereof. The selection of a suitable vehicle will be apparent to persons skilled in the art depending on such factors as the properties of the oral care agent and the desired properties of the medium, such as viscosity. Examples of tooth whitening compositions are described in U.S. Patents No. 6,770,266 and 6,669,930, the disclosures of which are hereby incorporated by reference.

[0072] The reservoir 11 can contain a quantity of the oral care agent medium intended for a single use or a small number of uses, or may facilitate repeated use over an extended period of time, e.g., up to several months or several years. The size of the reservoir 11 can be selected to be compatible with the desired overall dimensions of the toothbrush as well as such factors as the stability of the oral care agent and the quantity of medium administered during each application.

[0073] The supply of oral care agent in the reservoir 11 generally is free or substantially free of components which are incompatible with the oral care agent and/or the medium containing the oral care agent, such as incompatible toothpaste components as previously identified.

[0074] The toothbrush optionally can be provided with compartments and/or access panels for access to the various components, such as the power source and reservoir. The power source can be, for example, a replaceable or rechargeable battery as well known.

[0075] FIGS. 8-13 illustrate an oral care implement, such as a toothbrush 100, having a handle 103 and a head 105 which may be used for cleaning the teeth and soft tissue in the mouth, such as the tongue, interior surfaces of the cheeks, lips or the gums. Handle 103 is provided for the user to readily grip and manipulate the toothbrush, and may be formed of many different shapes and constructions. While the head is normally widened relative to the neck of the handle, it could in some constructions simply be a continuous extension or narrowing of the handle. The head 105 can have a first face 106 that supports tooth cleaning elements 107 (FIGS. 12 and 13) and a second face 108 that supports a tissue

cleaner 300 (FIGS. 9 and 10), which can have one or more outlets for dispensing fluid(s) as previously described. The first and second faces 106, 108 can be disposed on opposite sides of head 105. Nevertheless, tissue cleaner 300 may be mounted elsewhere, such as the proximal end 104 of handle 103. The tissue cleaner 300 or portions of it may also be located on the peripheral sidewall surface 101 of head 105 or extend farther towards the proximate end 104 of handle 103 than illustrated.

[0076] Tissue cleaner 300 can be configured with a multiplicity of tissue engaging elements 303 (FIGS. 8-12), which can be formed as nubs.

[0077] As seen in FIGS. 9 and 11, the nubs 303 can be conically shaped. With reference to FIG. 11, the base portion 305 of each conically shaped tissue engaging element 303 can be larger than the corresponding tip portion 307. In this conically shaped configuration, the base portion 305 has a wider cross-sectional area to provide effective shear strength to withstand the lateral movement of the tissue cleaner 300 along the surface of the tongue or other soft tissue surface.

[0078] As seen in FIG. 10, nubs 303 can be disposed in longitudinal rows in a direction generally parallel to the longitudinal axis a-a. Further, nubs 303 are disposed in transverse rows R1, R2 on an axis parallel to base surface 301 and generally perpendicular to the longitudinal axis a-a. Adjacent nubs 303 can be provided on the base surface 301 in a staggered arrangement. For example, adjacent transverse rows of nubs R1 and R2 can have nubs 303 that are not directly behind each other. A first nub is said herein to be "directly behind" second nub when it is located within the lateral bounds of the second nub extending in a longitudinal direction. This configuration enables improved cleaning of the soft tissue surfaces by facilitating the removal of microflora and other debris, and especially from the recesses of adjacent papillae of the tongue. Nonetheless, the nubs could be arranged randomly or in a myriad of different patterns.

[0079] Tongue cleanser 300 can be formed by being molded to head 105, although other manufacturing processes could be used. With reference to FIGS. 8 and 11, tissue cleaner 300 can be molded within a basin or a receiving cavity 111 in face 108 of head 105. The receiving cavity 111 has a lower base surface 113 and a peripheral sidewall 115 extending away from the lower base surface 113. In one mounting arrangement, nubs 303 of the tissue cleaner 300 are exposed for use with the base surface of the tissue cleaner 300 being flush or recessed relative to the surface 114 of the head. Nevertheless, other orientations are possible. Also, base surface 301 of the tissue cleaner could be embedded in head 105 or covered by another layer with nubs 303 projecting through appropriate openings.

[0080] As can be seen in FIGS. 8 and 11, face 108 also can include one or more peg members 117a-c disposed within basin 111. Peg members 117 form anchor points against the opposing mold to prevent the head from moving under the pressure of the injection molding. As a result, tissue cleaner 300 can include one or more complementary apertures 311a-c which exposes the tops of peg members 117a-c. Although, the pegs are illustrated in alignment along the centerline of the head (e.g. longitudinal axis a-a), the pegs could have many different positions. Further, the pegs and basin can both be included with head 105, but either could be used without the other.

[0081] Alternatively, basin 111 and peg members 117a-c may be provided to position and hold a previously molded tissue cleaner, although these constructions are not necessary to use such a previously molded tissue cleaner.

[0082] Peg members 117a-c may take on a variety of shapes and lengths. With continued reference to the FIGS. 8 and 11, head 105 includes peg members 117a-c extending away from the lower base surface 113 of basin 111 to the height of the peripheral sidewall 115. The peg members 117a-c are shaped in the form of a cylinder, but other shapes and lengths of the peg members 117a-c are possible. While the molding process can be used to bond the tissue cleaner to the head, the tissue cleaner could be preformed and attached by adhesive or other known means.

[0083] As shown in FIGS. 8-11, tissue cleaner 300 can be formed as a pad composed of a soft and pliable elastomeric material for comfortable cleaning and effective removal of bacteria and debris disposed on the surface of the tongue, other soft tissue in the mouth and even along the lips, as well as for dispensing the fluid(s) as previously described. The tissue cleaner 300 also can provide effective massaging, stimulation and removal of bacteria, debris and epithelial cells from the surfaces of the tongue, cheeks, gums or lips.

[0084] Referring to FIGS. 12 and 13, the tooth cleaning elements 107 of head 105 may include a variety of tooth cleaning elements which can be used for wiping, cleaning and massaging the user's teeth and gums. Any suitable form of tooth cleaning elements may be used. The term "tooth cleaning elements" is used in a generic sense which refers to filament bristles or elastomeric fingers or walls that have any desirable shape. In the illustrated example of FIG. 12, tooth cleaning elements 107 include distal tooth cleaning elements 203a-b disposed at a distal tip 121 of head 105, peripheral tooth cleaning elements 205a-l, longitudinal tooth cleaning elements 207a-c disposed along longitudinal axis a-a, arcuate tooth cleaning elements 209a-d and 211a-b, and proximal cleaning elements 213a,b. Tooth cleaning elements 205, 207, 211 and 213 can be provided as tufts of bristles whereas tooth cleaning elements 209 can be formed as elastomeric walls. Nevertheless, other forms and types of tooth cleaning elements may be used.

[0085] According to other embodiments, the wicking system outlet 15 may be integrated into a tissue cleaner such as the tissue cleaner 300 shown in FIG. 8-11. In lieu of the embodiment shown in FIGS. 1 and 3 wherein the fluid outlet 615 alone may be disposed on the opposite side of toothbrush head 2 from the tooth cleaning elements, the outlet 15 may be exposed and/or extend through various shaped apertures in the tissue cleaner to dispense the fluid from the toothbrush to the oral cavity of the user. FIGS. 17 and 18 show one possible exemplary embodiment of such a tissue cleaner incorporating one or more capillary outlets 15.

[0086] FIG. 17 shows an enlarged side cross sectional view of a toothbrush head 2 configured similarly to toothbrush head shown in FIGS. 1-3. FIG. 18 is a rear perspective view of the toothbrush head shown in FIG. 17.

[0087] Referring now to FIGS. 17 and 18, head 2 of toothbrush 1 includes a tissue cleaner 500 which may be disposed on a side of the head opposite the tooth cleaning elements such as bristles 6 and/or elastomeric elements 7 as shown in one possible embodiment. Tissue cleaner 500 may generally similar to tissue cleaner 300 and include a plurality of nubs 303 similarly to those shown in FIGS. 8-11 (but omitted for clarity in FIGS. 17 and 18) and/or other projecting tissue cleansing projections or textured surfaces. Capillary outlet/fluid outlet 15 is disposed beneath at least a portion of tissue cleaner 500 in a preferred embodiment. At least one, and preferably a plurality of apertures 501 may be formed in tissue cleaner 500 through which outlet extensions 502 extend outwards from outlet 15 and toothbrush head 2 in a direction generally transverse to the head and longitudinal axis of the toothbrush 1. Outlet extensions 502 are in fluid communication with capillary outlet 15 and may be made of the same or different capillary material as outlet 15. Outlet extensions 502 may be formed integrally with outlet 15 or may be structurally separate and attached to outlet 15 by any suitable means used in the art.

[0088] The free ends 504 of outlet extensions 502 may be flush with the outer exposed surface 503 of tissue cleaner 500 in some embodiments, or in other embodiments as shown extensions 502 may project outwards above surface 503 of tissue cleaner 500 to further enhance contact of the outlet extensions with oral surfaces and delivery of the active oral agent via capillary action. The height of outlet extensions 502 measured from surface 503 of tissue cleaner 500 to free ends 504 of extensions 502 may be less than, equal to, or greater than any tissue cleansing projections (such as nubs 303 shown in FIG. 11) provided on tissue cleaner 500. It is contemplated that in some embodiments, outlet extensions may have varying heights and need not be all the same.

[0089] In the exemplary embodiment shown in FIGS. 17 and 18, outlet extensions 502 (and corresponding apertures 501 in tissue cleaner 500) may be shaped as laterally

extending rectangular strips for illustration purposes. However, outlet extensions 502 may have any suitable shape or be any combination of different shapes including but not limited to circular, oval, polygonal, or other. In addition, it will be appreciated that any number of outlet extensions 502 may be provided and outlet extensions 502 may be positioned anywhere in tissue cleaner 500. Accordingly, the invention is expressly not limited by the shape, number, or placement of outlet extensions 502.

[0090] FIGS. 20-23 show another embodiment of an oral care device which may be in the form of a fluid dispensing toothbrush 600 including a fluid outlet 615 embedded in the head of the toothbrush in a similar manner to the embodiment shown and described in FIGS. 17 and 18. The toothbrush 600 and fluid outlet 15 may be configured slightly differently, however, as further described below.

[0091] Referring to FIGS. 20 and 21, toothbrush 600 includes a head 601, an adjacent neck 651 supporting the head, and an adjacent handle 602 supporting the neck 651 and defining a longitudinal axis LA for the toothbrush. Toothbrush 600 further includes a distal end 606 defined by head 601, a proximal end 607 defined by handle 602 and opposite end 606, and two laterally spaced apart lateral sides 608. Head 601 preferably includes a plurality of tooth cleaning elements 603 and soft tissue cleaner 700, which in one embodiment may be disposed on a rear side 604 of the head opposite the front side 605 supporting tooth cleaning elements 603. The tooth cleaning elements 603 may include a variety of tooth cleaning elements which can be used for wiping, cleaning and massaging the user's teeth and gums, such as without limitation in some embodiments those shown in FIGS. 12-13 and described herein. In some embodiments, tissue cleaner 700 may be configured similarly to cleanser 300 shown in FIGS. 8-11 and described herein. Preferably, tissue cleaner 700 includes a plurality of protruding nubs 303 similarly to those shown in FIGS. 8-11 and/or other projecting tissue cleansing projections or textured surfaces adapted for cleansing soft tissue in the oral cavity.

[0092] Referring to FIGS. 20 - 23, handle 602 of toothbrush 600 defines an internal longitudinally-extending cavity 813. Toothbrush 600 includes a fluid dispensing/delivery system, which in exemplary preferred embodiments includes fluid outlet 615, channel 14 and storage member 16 (also referred to herein shortened as "capillary storage"). The storage member 16 is a longitudinally-extending elongated capillary channel which is in fluid communication with channel 14 and outlet 15 in head 601 of toothbrush 600 in a similar manner as already described herein in some embodiments. Storage member 16 is preferably at least partially disposed in the cavity 813, as shown. Outlet 15, channel 14 and storage member 16 may be formed of a suitable wicking or capillary material; non-limiting examples of which include fibrous materials, ceramics, and porous plastics such

as those available from Porex Technologies, Atlanta, Georgia. One example of a fibrous material is an acrylic material identified as type number C10010, available from Teibow Hanbai Co., Ltd., Tokyo, Japan. A mixture of porous and/or fibrous materials may be provided which have a distribution of larger and smaller capillaries. The channel can be formed from a number of small capillaries that are connected to one another, or as a larger single capillary tube.

[0093] The storage member 16 may additionally be formed from any suitable material and may include reticulated foam, which may range from hydrophilic to hydrophobic. Hydrophobic foams may be used with non-water based liquids. An example of a reticulated foam is Bulpren S90, manufactured by Recticel (Wetteren, Belgium). Bulpren S90 is an open cell polyurethane foam based on polyester which averages 90 pores per inch. Hydrophilic foams may be used with water based liquids. Other examples of materials that can be used for the reservoir 11 include ceramics and porous plastics. In a preferred embodiment, the reservoir may be a commercially available bonded fiber component from Filtrona or Porex, such as without limitation polypropylene, polyethylene, or copolymers of such polymers in varying ranges of hydrophobicity depending on the composition selected..

[0094] At least a portion of the handle 602 may be made of a transparent or opaque material so that the amount of fluid in the storage member 16 is visible to a user. This allows the user to visually inspect the amount of fluid remaining in the toothbrush 600.

[0095] In some embodiments, storage member 16, channel 14 and outlet 15 may form components of a multi-stage capillary fluid dispensing/delivery system, embodiments of which are described elsewhere herein and shown in FIGS. 14-16 and 19, to regulate the delivery of fluid 13 from the toothbrush 600 to the user. In the embodiment shown in FIGS. 20 and 21, for example, a flow restrictor 609 similar in operating concept to flow restrictor 150 shown in FIG. 16 is provided in the form of reduced contact flow surface area between channel 14 and storage member 16. This creates different fluid 13 flow rates through each of the channel 14 and storage member 16. In this embodiment, channel 14 and storage member 16 are wicking structures which are abutted or otherwise coupled together in abutting relationship, and may be a unitary structure, to form a contiguous flow path but of different cross-sectional or transverse flow areas in which channel 14 has a diameter 610 that is preferably smaller than diameter 611 of storage member 16. When channel 14 is depleted of fluid during use and delivery from toothbrush 600, the fluid in the channel 14 will be replenished at a slower flow rate from adjoining storage 16 due to the presence of the flow restrictor 609 between those two fluid flow sections. In other embodiments, a differing rate of flow between channel 14,

storage member 16 and fluid outlet 15 may be created by making each member of a wicking material having a different flow characteristic based on the material selected, as further described herein with reference to FIG. 14. In yet other possible embodiments, as shown in FIG. 17, differing rates of flow may further be created between fluid outlet 15 and channel 14 by reduced cross-sectional surface contact between fluid outlet 15 and channel 14. As shown, this may be created by vertical and/or lateral offset 617 engagement between fluid outlet 615 and channel 14 where each element is mutually abutted. It will be appreciated that any of the methods as further described herein for regulating the flow via a multi-stage capillary fluid delivery system may be used as will be further described below.

[0096] It will be appreciated that any of the multi-stage capillary fluid dispensing/delivery arrangements shown in FIGS. 14-16 and 19 for regulating flow to be further described below may be incorporated into channel 14, capillary storage member 16, fluid outlet 615, or any combination thereof or such flow regulating means may be formed at the fluid junction between these members (see, e.g. FIGS. 17 or 20). Accordingly, a multitude of possible variations are contemplated based on the multi-stage capillary fluid dispensing/delivery arrangements and methods described herein.

[0097] With reference now back to FIGS. 20, 21 and 23, a fluid outlet 615 is similar to that already described herein and preferably disposed in an internal cavity or space formed in toothbrush 600 for dispensing fluid 13 to the user. In this embodiment, fluid outlet 615 extends into neck 651 and partially into head 601. Fluid outlet 615 is in fluid communication with channel 14, and in some embodiments may be formed as an integral unitary part of the same capillary channel structure as shown. At least one aperture 612 is formed through rear side 604 in toothbrush head 601 through which outlet extension 613 protrudes outwards from fluid outlet 615 and toothbrush head 2 in a direction generally transverse to the head and longitudinal axis of toothbrush 600. Outlet extension 613 is therefore in fluid communication with fluid outlet 615 and may be made of the same or different capillary material as outlet 15. Outlet extension 613 may be formed integrally with outlet 15 or may be structurally separate attached to outlet 15 by any suitable conventional means used in the art.

[0098] In one possible embodiment, as shown in FIGS. 20 and 21, outlet extension 613 and corresponding aperture 612 may be longitudinally elongated and axially aligned with longitudinal axis of toothbrush 600 as shown. In one possible exemplary configuration, outlet extension 613 extends from distal end 606 of toothbrush head 601 rearwards towards proximal end 607 for a distance that covers a majority of the axial length of head 601 as shown. In the embodiment shown, outlet extension 613 is preferably embedded

within tissue cleaner 700. This arrangement advantageously allows the user to dispense the fluid 13 simultaneously with using the tissue cleaner 700. The outlet extension 613 is stimulated when the user rubs the tissue cleaner and extension over soft oral tissue to activate flow of fluid 13 from the toothbrush head 601 thereby dispensing the provided fluid.

[0099] Fluid outlet extension 613 may have any suitable shape or be comprised of any combination of different shapes including but not limited to linear, rectilinear, circular, oval, polygonal, or other. In addition, it will be appreciated that any number of outlet extensions 613 may be provided and positioned anywhere on rear side 604 of toothbrush head 601. Accordingly, the invention is expressly not limited by the shape, number, or placement of outlet extensions 613.

[00100] With continuing reference to FIGS. 20 and 21, the free end 614 of outlet extension 613 may be substantially flush with the outer exposed surface of tissue cleaner 700 in some embodiments, or in other embodiments extension 613 may project outwards above the surface of tissue cleaner 700 to further enhance contact of the outlet extension with oral surfaces and delivery of the active oral agent via capillary action. Accordingly, the height of outlet extension 613 measured from the exposed outer surface of tissue cleaner 700 to free end 614 may be less than, equal to, or greater than any tissue cleansing projections (such as nubs 303 shown in FIG. 11) provided on the tissue cleaner 700. It is contemplated that in some embodiments, outlet extension 613 may have varying heights along its length and need not be all the same or uniform in height from end to end.

[00101] In the embodiment shown in FIG. 20, outlet extension 613 has a lateral width that is substantially coextensive with the width of fluid outlet 615 disposed in toothbrush head 601. In other embodiments, the width of outlet extension 613 may vary and be larger or smaller than fluid outlet 615 to which it is fluidly coupled.

[00102] In operation, with reference to FIG. 21, fluid flows via capillary action from storage member 16 (which remains wetted by the fluid in the and acts as an inlet flow conduit), then into channel 14, and next into fluid outlet 15 and outlet extension 613 from which the fluid is dispensed from toothbrush 600 to the user (see directional fluid flow arrows). As described herein, engagement between an oral surface and outlet extension 613 activates and stimulates flow of fluid 13 via wicking or capillary action through the foregoing fluid delivery system components.

[00103] Referring now to FIGS. 20-22, embodiments of toothbrush 600 may further include an end cap 800 disposed on proximal end 607 of handle 602. End cap 800 in one possible embodiment may be a two-piece component including a toothbrush

handle plug 801 that closes off proximal end 607 of handle 602 and a valve plug 802 secured to the handle plug as best shown in FIG. 22 which is an enlarged cross-sectional view of the end cap. Handle plug 801 may be removable or permanently attached to the proximal portion of handle 602 via at least one annular locking grooves 803 which engage corresponding and complementary shaped interlocking annular locking ribs 804 disposed on a radially flexible locking portion 805 of handle 602 as shown (see FIGS. 20 and 21). In one embodiment, flexible locking portion 805 may be defined by a reduced diameter and thickness section of handle 602 which is inset from the main surface 806 of the handle to receive a corresponding locking portion 807 of handle plug 801. Grooves 803 and ribs 804 form a mechanical snap-lock mechanism for securing the handle plug 801, and concomitantly in turn the end cap 800 to handle 602.

[00104] Valve plug 802 may be removably or permanently secured to toothbrush handle plug 801 in a similar fashion with at least one annular locking rib 824 disposed on the handle plug which engages a corresponding annular locking groove 825 formed in the valve plug as best shown in FIG. 22. Annular locking rib 824 preferably is disposed on a radially flexible locking portion 826 of handle plug 801 configured similarly to radially flexible locking portion 805 of handle 602 described above.

[00105] It will be appreciated that the foregoing locking grooves 803, 825 may instead alternately be reversed and disposed on toothbrush handle 602 and handle plug 801, respectively, and concomitantly locking ribs 804, 824, may alternately be reversed and disposed on handle plug 801 and valve plug 802, respectively, or any combination of the foregoing described arrangements may be used.

[00106] With continuing reference FIGS. 20-23, a check valve 820 and vent opening 821 are provided in handle 602 to maintain the correct air pressure in cavity 813 for dispensing the optimal dose of fluid to the user. Check valve 820 is operative to allow air to enter cavity 813 through a vent opening 821 in valve plug 802 thereby advantageously maintaining the reservoir preferably at or near atmospheric pressure. When fluid is dispensed from toothbrush 600, a temporary vacuum is created as the fluid contained in storage member 16 is being drawn away and partially depleted. The vent opening 821 allows air to rush into the reduced pressure environment in the cavity 813 behind the fluid flow to counter-balance the temporary pressure drop therein so that fluid continues to flow through the wicking system at or near the predetermined desired rate of flow (see directional air flow arrows in FIG. 22). At the same time, check valve 820 is operative to prevent the leakage of fluid 13 outwards from cavity 813 through vent opening 821 when the check valve is not admitting air into reservoir 11. Accordingly,

check valve 820 has an inlet in communication with vent opening 821 and is operative to permit flow in only one direction (i.e. inwards into the reservoir).

[00107] With continuing reference to FIGS. 20-23, check valve 820 is secured in valve plug 802 by annular valve seat 822 defined by valve plug 802. Toothbrush handle plug 801 defines an annular surface 822 which is configured to engage check valve 820 to trap the valve on the valve seat 822 when the valve plug 802 is attached to the handle plug (see, e.g. FIG. 22). In one possible embodiment, check valve 820 may be an elastomeric valve such as a “duck bill” type valve as shown having two flexible flap portions 827 that are mutually but movably engaged. Other suitable elastomeric or conventional spring loaded check valves as will be readily known to those skilled in the art may be used. Accordingly, the invention is not limited to use with any particular type of check valve so long as air may be admitted into reservoir 11 and fluid 13 is prevented from leaking out through vent opening 821.

[00108] End cap 800 preferably is made of a conventional plastic material used in the art, and more preferably a relatively rigid plastic. In other embodiments, cap 900 may alternatively be made of a suitable flexible elastomeric material. Toothbrush handle plug 801 and a valve plug 802 may be made of the same or different materials in various embodiments, with either one being made of a rigid plastic or flexible elastomeric material. In one exemplary embodiment, without limitation for example, handle plug 801 and valve plug 802 may be made of polypropylene.

[00109] Referring to FIGS. 24-28, toothbrush 600 further includes a storage cap 900 configured and adapted to be removably secured to toothbrush head 601. Storage cap 900 is intended to at least partially seal and reduce/minimize the evaporative loss of fluid from exposed portions of fluid outlet 615 such as outlet extensions 501 or 613 described herein. Accordingly, in one preferred exemplary embodiment, storage cap 900 generally conforms in shape to toothbrush head 601 as shown. Storage cap 900 includes a longitudinally-extending body 901 defining a sealing socket 902 which is configured to complement and conform to the shape of and receive therein outlet extension 613 in this embodiment (see also FIGS. 20-21). In one embodiment, sealing socket 902 is axially elongated and generally channel shaped. Socket 902 includes raised lateral walls 903 which conform to the shape of the outlet extension 613 and have a height suitable to engage an exposed peripheral surface 650 of rear side 604 of toothbrush head 601 at least partially, and more preferably substantially fully surrounding outlet extension 613 when the cap is fully seated on toothbrush head 601. Peripheral surface 650 is specifically provided between outlet extension 613 and tissue cleaner 700 for receiving and engaging raised walls 903 of socket 902 to form a primary seal therebetween to minimize

evaporative fluid loss from the outlet extension 613. Storage cap 900 preferably has an open bottom 912 defined between lateral cap sidewalls 904 through which tooth cleaning elements 603 may extend when the cap is seated on toothbrush head 601.

[00110] With continuing reference to FIGS. 23-27, sealing socket 902 has an axial or longitudinal length substantially coextensive with the length of outlet extension 613. In the embodiment shown, sealing socket 902 preferably also includes an angled distal end wall 913 that is angled towards bottom 912 of storage cap 900 and conforms in shape to and covers the distal most end portion of outlet extension 613. Sealing socket 902 preferably further includes a proximal end wall 914 that conforms in shape to and covers the proximal most end portion of outlet extension 613. In conjunction with lateral sidewalls 903, distal and proximal end walls 913, 914 of socket 902 provide complete sealing of outlet extension 613 to minimize evaporative fluid loss during storage of fluid dispensing toothbrush 600.

[00111] With continuing reference to FIGS. 23-27, storage cap 900 further includes a pair of opposing spaced apart lateral sidewalls 904 and adjoining distal end wall 910 all of which are preferably configured to substantially conform to the shape of toothbrush head 601. In some embodiments, sidewalls 904 and end wall 910 may at least partially engage a portion of lateral sides 608 of toothbrush head 601 to provide a secondary seal between the storage cap 900 and toothbrush head for reducing evaporative loss from outlet extension 613 in the event the primary socket seal is not completely effective or slightly ajar.

[00112] Storage cap 900 further includes a means for temporarily and removably securing the cap to toothbrush head 601. In one embodiment, with continuing reference to FIGS. 23-27, the securing means includes a distal hook 905 formed on a distal end wall 910 of cap 900 which is configured and adapted to engage a complementary shaped undercut 908 formed on distal end 606 of toothbrush head 601. This secures the distal end of storage cap 900 to toothbrush head 601. In some embodiments, the securing means further includes a pair of laterally spaced apart latching tabs 906 disposed on a proximal portion of storage cap 900. Latching tabs are configured and adapted to engage a pair of complementary shaped undercuts 909 formed on portion of toothbrush neck 651. Proximal end 907 of storage cap 900 is preferably open to receive a portion of neck 651 therethrough as shown.

[00113] Storage cap 900 preferably is made of a conventional plastic material used in the art, and more preferably a relatively rigid plastic. In other embodiments, cap 900 may alternatively be made of a suitable flexible elastomeric material.

[00114] Multi-Stage Capillary Fluid Delivery System

[00115] According to another aspect of the invention, a multi-staged capillary or wicking fluid delivery system is provided to regulate the dispensing flow rate of the fluid and/or oral care agent to the user. In some embodiments, such as those previously described herein with respect to FIGS. 4-7, controlling the relative dose and delivery of a fluid from an oral care implement to a user relies mainly on exposure time and the wicking speed through the capillary channel(s). Since users do not all brush or cleanse the teeth and/or oral soft tissue (i.e. tongue, gums, interior of mouth, etc.) in the same manner (e.g. lips open or closed, fast or slow brush strokes, high or low pressure between brush/tongue cleaner and teeth and/or tissue, etc.) or for the same period of time, this may produce variability in the dispensing rate and does not allow for precise dosing of the fluid.

[00116] Prior known capillary or wicking systems in non-oral fields have focused mainly on applications in which steady continuous flow is often desired. For example, in writing pen and highlighter marker applications, the ideal product delivery is a steady continuous flow which does not diminish during usage. In some situations, this kind of continuous flow would also be desirable for some oral care applications. However, in instances involving high frequency of brushing/cleansing activity or where highly regulated oral care agents would be delivered to the user, it may be desirable to more precisely regulate the flow of the agent to prevent overdose or over-application of the agent.

[00117] A multi-stage capillary or wicking fluid delivery system now described provides a non-continuous dispensing system which interrupts the otherwise continuous capillary wicking action of the active-agent containing fluid to provide greater control over the dosing and delivery rate of the fluid to the user. The multi-stage capillary fluid delivery system further reduces or eliminates variability in agent delivery rates based on the user's brushing or cleansing habits.

[00118] FIG. 14 is a schematic diagram of one exemplary embodiment of a multi-stage capillary fluid dispensing system according to the present invention. The system includes a capillary device 100 having a channel 14 that is in direct or indirect fluid communication with a fluid reservoir 11 holding a fluid 13 containing an oral care agent. Reservoir 11 may include capillary storage such as capillary storage 16 shown in FIGS. 4-7 and described herein which is in fluid communication with channel 14. Channel 14 preferably is formed of a first wicking or capillary member 122 defining a flow section 120 and a second wicking or capillary member 123 defining a second flow section 121. Flow sections 120 and 121 are in fluid communication with each other and reservoir 11. In one possible embodiment, flow section 120 may be directly coupled to flow section

121 as shown. In other embodiments, intermediary flow conduits (not shown) may be provided between flow sections 120 and 121 (not shown).

[00119] Each of the wicking or capillary members 122 and 123 are structured and formed of a wicking material as further described herein so that the fluid flow rate or throughput through each wicking member via capillary or wicking action is different. Accordingly, in a preferred embodiment, wicking member 122 forming flow section 120 has a first fluid flow rate R1 and wicking member 123 forming flow section 121 has a second fluid flow rate R2 that is different than the first flow rate. In this exemplary embodiment, fluid flow rate R1 preferably may be lower/slower than fluid flow rate R2 (as illustrated by the flow arrows in FIG. 14).

[00120] With continuing reference FIG. 14, flow section 121 in one embodiment is preferably fabricated for fast or high rate of flow to transmit and deliver a fluid volume stored therein quickly in a short period of time via capillary or wicking action relative to flow section 120. In some embodiments, flow section 121 may contain a predefined dose of a fluid and may empty its volume completely upon activation by a user to administer the set dose.

[00121] By contrast, flow section 120, which is preferably fabricated for a slower or lower rate of flow relative to flow section 121, replenishes the fluid in section 121 via capillary or wicking action slowly. For example, in some representative embodiments, without limitation, it may take from several minutes to approximately 1-2 hours or more for this to occur depending on the oral care agent in the fluid to be dosed to a user and dosage limitations associated with the oral care agent. Preferably, flow section 120 is fabricated so that replenishment of fluid in flow section 121 does not substantially occur simultaneously during usage (i.e. during emptying of section 121). Accordingly, there is preferably a lag time or replenishment period between the time in which the contents of section 121 are fully expelled and dispensed to a user and the time in which section 121 is fully replenished with a new charge of fluid 13. In some embodiments, this lag time may be several minutes to one or more hours. This works to deliver a maximum predefined dose of oral care agent to the user from the fluid charge already stored in flow section 121 prior to use and ready for delivery to the user.

[00122] In some embodiments, flow section 120 may further be fabricated to have a larger volumetric fluid storage capacity than flow section 121 which may serve as the fluid dosing portion of the channel 14. Since flow section 120 has a slower flow rate and therefore replenishment rate than section 121 in one embodiment, it is preferable that section 120 have a larger fluid storage capacity than section 121 so that there is sufficient fluid readily available to fully recharge section 121 when its fluid contents are emptied

upon delivering a dose to a user. Accordingly, in some embodiments, flow section 120 may have a longer axial length and/or larger transverse cross-section than section 121. It will be appreciated that channel 14 and flows sections 120 and 121 may further have any suitable transverse cross-sectional shapes such as without limitation circular or segments/portions thereof, oval/elliptical or segments/portions thereof, and polygonal. Each flow section 120, 121 may further have a different transverse cross-sectional shape than the other flow section. Accordingly, the invention is not limited to any particular cross-sectional shape, dimensions, or lengths of wick or channel 14 which will be dictated by the particular application and housing to be used.

[00123] In some embodiments, referring to FIG. 14, flow section 121 may be fluidly coupled to an outlet such as a conventional applicator 130 for administering the fluid with oral care agent directly to the user via surface contact with the applicator. The surface contact activates and stimulates the flow of fluid 111 via capillary action from reservoir 13 through channel 14 and ultimately outwards from applicator 130 to the intended target delivery surface. In some embodiments, the delivery surface may be a tooth or tissue surface in the oral cavity of the user. In some embodiments, applicator 130 may be conventional nib formed of any suitable porous fluid-transmitting material as described herein and known to those skilled in the art. In other embodiments, flow section 121 may deliver its fluid contents via any other type of suitable outlet such as fluid outlets 15 already described herein with reference to FIGS. 1-13, which in some embodiments may be incorporated into an oral care implement such as toothbrush 100 or other dispensing device. Other suitable fluid outlets that may be used in conjunction with flow sections 102, 121 and channel 14 may be incorporated into a tongue cleaner such as described herein elsewhere with respect to FIGS. 17 and 18. In yet other possible embodiments, a separate applicator or outlet structure may be omitted entirely and flow section 121 may be configured and adapted to administer the fluid dose directly to the user.

[00124] It will be appreciated that the foregoing exemplary multi-stage wicking construction of capillary device 100 and channel 14 with flow sections 120, 121 advantageously provides the ability to deliver a predefined dose of fluid 13 with oral care agent to a user. This provides an intermittent flow mechanism and greater fluid flow control in contrast to continuous flow type capillary and wicking systems when it is desired to regulate and administer a specific dose of an oral care agent to a user within a given treatment time period.

[00125] Wicking or capillary members 122, 123 forming fluid flow sections 120, 121 respectively may be made of any suitable wicking material having fluid capillary and

wicking action properties such as those already described herein elsewhere. Accordingly, the differential flow rates R1 and R2 of flow sections 120 and 121, respectively, may be accomplished by a variety of means, including wicking material selection and/or the physical or structural design of wicking members 122, 123 using the materials and techniques already described herein with reference to FIGS. 1-13. These include, but are not limited to differences in wicking materials for constructing flow sections 120 and 121 including differing porosities (e.g. various foams or fibrous material) and/or chemical compositions (e.g. chemically-modified silica). This provides each of wicking members 122 and 123 with specific capillarities or wicking properties/characteristics to meet the desired flow rates.

[00126] The rate and amount of fluid 13 delivered or transferred from one flow section to another section thus may be controlled by using suitable wicking materials having different capillary properties for each flow section 120 and 121 of the multi-stage fluid delivery system. Some exemplary suitable wicking materials may include polymers such as polyethylene, polypropylene, celluloses, wools, polyesters, collagens, nylons, and blends thereof. The polymer void volume, porosity, pore size, density, size and shape can all be tailored to provide the desired fluid release or flow rate characteristics from one flow section 120 to the other section 121. Additionally, the wicking materials can be treated with food grade surfactants to change their hydrophobicities and/or hydrophilicities which would also help control the rate of fluid release/flow and replenishment from one flow section to another.

[00127] Alternatively, as schematically illustrated in FIG. 14, fluid flow may be controlled between wicking members 122 and 123 by providing a flow restrictor 170 (between the wicking members such as without limitation a unidirectional or bidirectional flow gate or valve, a porous membrane, a perforated partition plate, or a diaphragm. The flows restrictors 170 regulate flow of fluid 13 between flow section 120 and reservoir 11, flow sections 120 and 121, and/or flow section 121 and applicator 130 (if provided). In some embodiments, the flow restrictor may be designed to open and/or permit fluid 13 to pass therethrough when a specific predetermined threshold pressure differential or flow has been obtained. This would have advantages such as more rapidly releasing a larger volume and reducing back-flow of liquid into the reservoir.

[00128] In some embodiments, the wicking material used for channel 14 may be one continuous strip of material having differing physical and chemical properties along its core length with differing capillarities to define flow sections 120 and 121. In other embodiments, each flow section 120, 121 may be separate components and modular in design wherein each flow section of a material having differing physical and/or chemical

properties and thus different capillarities can be simply joined together via any suitable means used in the art such as mechanical, adhesive, or other means. In some exemplary embodiments, flow section 121 may be plugged or snapped into section 120 and vice versa (via reduced cross-sectional extensions of either flow section) or simply press fit together with a housing or other support structure that maintains axial pressure between two opposing abutting ends of flow sections 120 and 121.

[00129] Using the foregoing principles of a multi-stage wicking or capillary system, it will be appreciated that some embodiments of channel 14 may be constructed with more than two flow sections allowing the designer to customize the flow rate of fluid through various portions of the capillary channel and delivery of the oral care agent to the user.

[00130] Additionally, the wicking system may be designed in a concentric tubular and onion-layer like design where each "onion" layer or tube has differing fluid release characteristics using the materials, construction, and same design principles described herein. This embodiment of a wicking system may be configured as a combination of two or more concentric rings of wicking material (similar to those of a tree trunk). In some embodiments, the different layer rings could be extruded from different type of wicking materials that create variable wicking characteristics. The variable wicking could deliver some fluid quicker and then some fluid slower depending on the densities, material composition selected, or layer thickness. One exemplary embodiment of such a multi-layer wicking system is shown in FIG. 19.

[00131] FIG. 19 shows a cross section of a capillary channel 200 including a combination of concentrically-aligned wicking or capillary members having different wicking characteristics or capillarities. Capillary channel 200 includes an inner-most first wicking or capillary member 201, a second wicking or capillary member 202 circumferentially disposed adjacent and in contact with member 201, and a third wicking or capillary member 203 circumferentially disposed adjacent and in contact with member 202, as shown. In one possible embodiment, capillary channel 200 may be directly or indirectly fluidly coupled to a reservoir such as reservoir 13 shown in FIGS. 14-16 or reservoir 13 shown in FIGS. 4-7. Each of the wicking or capillary members 201-203 are structured and/or formed of a wicking material as further described herein so that the fluid flow rate or throughput through each wicking member via capillary or wicking action is different. Accordingly, in a preferred embodiment, wicking member 201 has a first fluid flow rate R_1 , wicking member 202 has a second fluid flow rate R_2 , and wicking member 203 has a third fluid flow rate R_3 . In preferred embodiments, at least two flow rates R_1 - R_3 , and in other embodiments all three flow rates R_1 - R_3 may be

different than each other to control and establish the intended rate of flow. It will be appreciated that other embodiments may have more or less concentrically aligned wicking members.

[00132] Additional embodiments of a multi-staged capillary or wicking fluid delivery system incorporating at least one flow restrictor between adjacent wicking or capillary members of channel 14 will now be described. Referring to FIG. 15, a flow restrictor 150 may be formed by physically reducing the contact surface area or cross-sectional flow area between adjacent fluid flow sections of channel 14, thereby inherently decreases the rate of fluid flow between each section. FIG. 15 shows one possible embodiment of a channel 14 formed of a single unitary wicking or capillary member 163 defining three separate flow sections 160, 161, and 162 with flow restrictors 150 formed or disposed between each section. However, it will be appreciated that more or less flow sections and/or flow restrictors may be provided in other embodiments.

[00133] Referring to FIG. 15, flow restrictors 150 may be formed by notched portions of the capillary channel or wick. The notched portions of flow restrictors 150 extend partially through wicking member 163 in a direction generally transverse to the longitudinal axis LA of the capillary channel, thereby leaving relatively smaller connective bridges 164 between flow sections 160, 161, and 162. Flow restrictor 150 on either side of center flow section 161 reduces the flow rate between section 161 and both lateral flow sections 160 and 162 due to the reduction in cross-sectional area available to convey fluid 13 in relation to the rest of the wicking member 163. Accordingly, flow restrictor 150 preferably has a smaller cross-sectional flow area than adjoining flow sections 160, 161, and 162 of wicking member 163. In one possible embodiment, section 160 may be in fluid communication with a reservoir 11 holding a fluid 13 containing an oral care agent. Fluid 13 is transferred through wicking member 163 via wicking or capillary action. In other embodiments, any of flow sections 160, 161 and/or 162 may be in fluid communication with fluid reservoir 11 depending on the intended design.

[00134] With continuing reference to FIG. 15, the operational principle is that the available fluid 13 retained in flow section 162 will be more rapidly delivered and depleted during the application process but replenished at a slower flow rate from adjoining flow section 161 due to the presence of the flow restrictor 150 between those two flow sections. Fluid will wick into one flow section (e.g. section 161), slow down because of the flow restrictor 150, and then wick or flow into the next downstream flow section (e.g. section 162). Accordingly, the impedance of flow through the serial arrangement shown of one or more flow restrictors and consequently each flow section downstream thereof acts to regulate the fluid 13 ultimately supplied to the user during

application. The more upstream flow restrictors 150 such as the notches or other suitable flow restrictors that are provided in series, the longer it ultimately takes for the flow section 163 to be replenished.

[00135] FIG. 16 shows another embodiment of a channel 14 having a flow restrictor 150 in the form of reduced contact flow surface area between flow sections 160 and 161. In this embodiment, flow sections 160 and 161 are separate unitary structures being defined by separate wicking members 163 and 165 respectively which are abutted or otherwise coupled together to form a contiguous flow path. The abutted portions of wicking members 163 and 165 defined connective bridge 164 allowing flow to pass from one flow section 160 to second flow section 161. In one embodiment, flow section 160 may be fluidly coupled to fluid reservoir 11 as shown. Flow section 161 may be fluidly coupled to a fluid outlet which may be a conventional applicator 130 in some embodiments or other suitable outlet such as those described herein with respect to FIGS. 1-14.

[00136] There are a variety of other ways to form flow restrictor 150 to restrict the flow rate between different adjacent flow sections as described herein, including but not limited to: abutting at least part of an end portion of the wick or capillary member against a hard preferably nonporous surface to reduce the flow path cross-sectional area or contact area between flow sections; heat fusing or applying a non-permeable sealant to at least part of the cross-sectional end portion of the flow sections to seal at least some of the pores; cutting various other shapes or other regions from the channel 14 or wick; providing more narrowly structured flow sections with smaller cross-sectional flow path cross-sectional areas between flow sections; inserting a partition wall between adjoining flow sections that has perforations or which is formed a wicking material having a lower flow throughput rate than the adjoining flow sections.

[00137] The foregoing capillary devices 100 with wicking or capillary members of capillary channels 14 shown in FIGS. 14-16 may be incorporated into any of the housings shown and described herein in FIGS. 4-7, or other suitable housings capable of supporting the wicking members. It will be appreciated that capillary devices 100 in some embodiments need not be incorporated into an oral care implement such as a toothbrush shown in FIG. 1. Accordingly, capillary devices 100 may be used in a pen-type applicator in some embodiments used for applying a fluid containing an oral care agent as described elsewhere herein. In yet other embodiments, capillary devices 100 may be disposed in any suitable housing used in applications completely unrelated to oral care. Accordingly, the invention is not limited to use in oral care applications alone.

[00138] It will be understood that while the invention has been described in conjunction with specific embodiments thereof, the foregoing description and examples are intended to illustrate, but not limit the scope of the invention. Other aspects, advantages and modifications will be apparent to those skilled in the art to which the invention pertains, and these aspects and modifications are within the scope of the invention and described and claimed herein.

CLAIMS

1. A fluid dispensing oral care implement, comprising:
a head including at least one tooth cleaning element;
a storage member for storing a fluid;
at least one fluid outlet disposed in the head; and
a channel fluidly coupling the storage member to the outlet,

wherein the channel transfers fluid at a first fluid flow rate to the outlet and the outlet transfers fluid to a user at a second fluid flow rate, the first fluid flow rate being different than the second fluid flow rate.
2. The oral care implement of claim 1, wherein the channel is formed of a first wicking material and the outlet is formed of a second wicking material.
3. The oral care implement of claim 2, wherein the first wicking material is the same as the second wicking material.
4. The oral care implement of any one of the preceding claims, further comprising a lateral offset between the outlet and the channel.
5. The oral care implement of any one of the preceding claims, wherein the outlet and the channel are unitary.
6. The oral care implement of claim 2, wherein the first wicking material has an associated characteristic first wicking flow rate and the second wicking material has an associated characteristic second wicking flow rate different than the first flow rate, the second wicking member being fluidly coupled to the first wicking member, wherein the fluid flows via capillary action through the first wicking material and second wicking materials at different wicking flow rates.
7. The oral care implement of any one of the preceding claims, further comprising a flow restrictor disposed between the storage member and the channel, the fluid flowing through the flow restrictor at a reduced rate of flow that is smaller than a rate of flow through at least one of the storage member and the channel.

8. The oral care implement of claim 7, wherein the flow restrictor comprises a reduced cross-sectional area between the storage member and the channel.
9. The oral care implement of any one of claims 7 or 8, wherein the flow restrictor is a valve or orifice.
10. The oral care implement of any one of the preceding claims, wherein the channel is disposed at least partially within the storage member.
11. The oral care implement of any one of the preceding claims, wherein the channel and the storage member are cylindrical in shape and concentrically aligned with each other.
12. The oral care implement of any one of the preceding claims, wherein the fluid outlet includes an extension having an exposed portion protruding outwards from a surface of the head of the oral care implement.
13. The oral care implement of any one of the preceding claims, wherein the fluid outlet is disposed at least partially within a tissue cleaner attached to the head of the oral care implement.
14. The oral care implement of any one of the preceding claims, wherein the capillary storage member is made of a wicking material.
15. The oral care implement of claim 2, wherein the storage member is formed of a third wicking material different than the first and second wicking materials, the third wicking material having an associated characteristic flow rate that is different than an associated characteristic flow rate of the first and second wicking material, wherein the storage member and channel operate to cause the fluid flows through the storage member and channel at different flow rates.
16. The oral care implement of any one of the preceding claims, wherein the channel and the storage member are longitudinally elongated, the channel having an end in fluid communication with the storage member that is smaller in cross-sectional area than the storage member.
17. The oral care implement of claim any one of the preceding claims, further comprising a handle having a transparent portion, wherein the storage member is visible through the handle.
18. The oral care implement of claim any one of the preceding claims, further comprising a storage cap removably attachable to the head of the toothbrush, the cap including a sealing socket configured to substantially conform to the shape of the fluid outlet.

19. A fluid dispensing toothbrush, comprising:
 - a head including a plurality of tooth cleaning elements and a tissue cleaner;
 - a handle coupled to the head;
 - a storage member disposed in the handle for storing a fluid;
 - at least one fluid outlet disposed in the head;
 - a channel fluidly coupling the storage member to the outlet, wherein the fluid flows via capillary action through the capillary channel to the outlet from which the fluid is dispensed; and
 - a valve disposed in the handle and in communication with a vent opening disposed in the handle, the valve being operative to introduce external air into the reservoir via the vent opening.
20. The fluid dispensing toothbrush of claim 19, wherein the at least one fluid outlet is formed of a wicking material.
21. The fluid dispensing toothbrush of any one of claims 19 or 20, wherein the channel is formed of a wicking material.
22. The toothbrush of any one of claims 19-21, further comprising an end cap disposed on a proximal end of the toothbrush, the valve being seated in the end cap.
23. The toothbrush of any one of claims 19-22, wherein the vent opening is disposed in the end cap.
24. The toothbrush of any one of claims 19-23, wherein the end cap is a two-piece component including a toothbrush handle plug that closes off the proximal end of the handle and a valve plug secured to the handle plug.
25. The toothbrush of claim 24, wherein the valve is retained in the end cap by being trapped between the valve plug and handle plug.
26. The toothbrush of any one of claims 24 or 25, wherein the handle plug is snap-fit to the handle.
27. The toothbrush of any one of claims 19-26, wherein the valve is an elastomeric check valve operative to allow one-way flow of external air into the reservoir.

28. The toothbrush of any one of claims 19-26, wherein the handle comprises a transparent portion.
29. A fluid dispensing toothbrush comprising:
- a head including a plurality of tooth cleaning elements;
 - a storage member for storing a fluid;
 - at least one fluid outlet disposed in the head for dispensing the fluid and having a shape;
 - a channel fluidly coupling the storage member to the outlet; and
 - a storage cap removably attachable to the head of the toothbrush, the cap including a sealing socket configured to substantially conform to the shape of the fluid outlet,
- wherein when the storage cap is attached to the toothbrush head, the socket is operative to at least partially seal the fluid outlet to minimize evaporative loss of the fluid.
30. The toothbrush of claim 29, wherein the channel is formed of a wicking material.
31. The toothbrush of any one of claims 29 or 30, wherein the storage cap includes a means for detachably securing the cap to the toothbrush head.
32. The toothbrush of claim 31, wherein the means for securing includes a hook disposed on a distal end of the storage cap that engages a complementary shaped undercut formed a distal end of the toothbrush head.
33. The toothbrush of claim 31, wherein the means for securing further includes a pair of laterally spaced apart latching tabs disposed on a proximal portion of storage cap, the latching tabs configured and adapted to engage a pair of complementary shaped undercuts formed on the toothbrush.
34. The toothbrush of any one of claims 29-33, wherein the sealing socket has an axially elongated channel shape.
35. The toothbrush of any one of claims 29-34, wherein the storage cap includes an elongated body and the sealing socket is disposed on elongated body.

36. The toothbrush of claim 35, wherein the storage cap further includes an open bottom through which the plurality of tooth cleaning elements protrudes therethrough when the cap is attached to the toothbrush head.
37. The toothbrush of claim any one of claims 29-36, further comprising a handle comprising a transparent portion.
38. A method for dispensing a fluid from an oral care implement, comprising:
- filling at least partially a fluid outlet disposed in an oral care implement with a fluid;
 - contacting an oral surface of a user with the fluid outlet;
 - wicking the fluid through the fluid outlet;
 - dispensing the fluid onto the oral surface at a first flow rate from the fluid outlet; and
 - refilling the fluid outlet from a channel fluidly coupled between the fluid outlet and a storage member containing the fluid, wherein the fluid outlet is refilled with fluid from the channel at a second flow rate that is different than the first flow rate of the fluid dispensing from the outlet.
39. The method of claim 38, further comprising a step of drawing air into a handle of the oral care implement during the dispensing step.
40. The method of any one of claims 38 or 39, wherein the dispensing step includes dispensing the fluid from a tissue cleaner disposed on the oral care implement.
41. The method of any one of claims 38-40, wherein the oral care implement is a toothbrush.

1/15

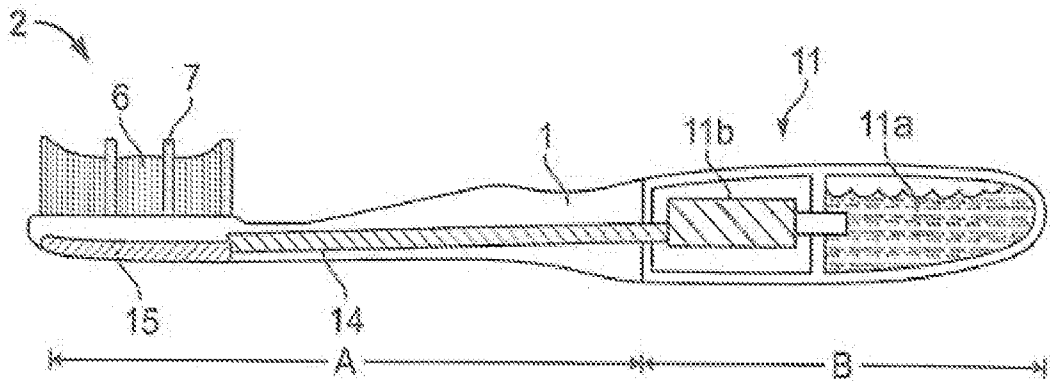

FIG. 1

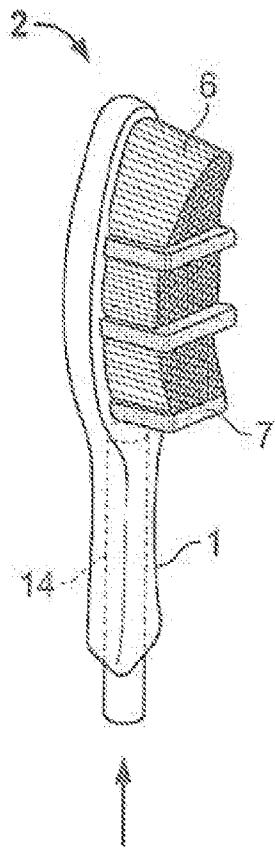

FIG. 2

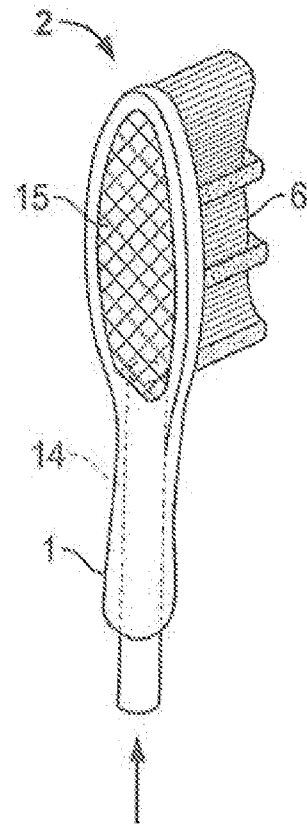

FIG. 3

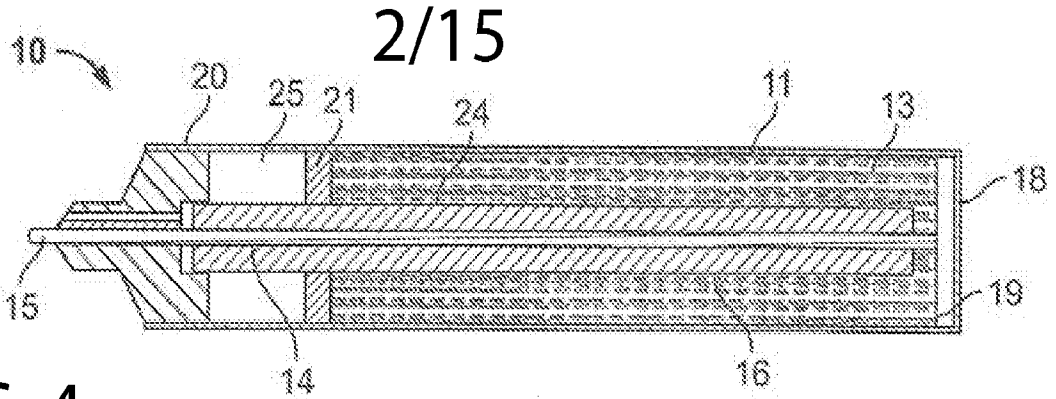

FIG. 4

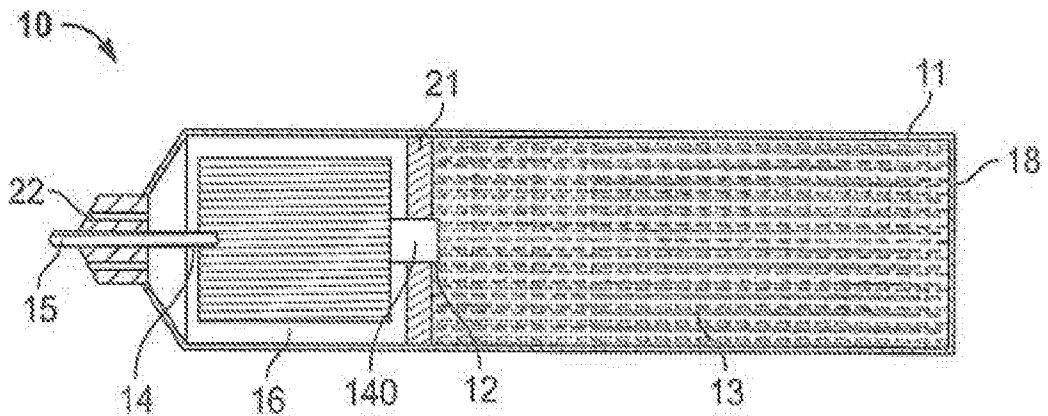

FIG. 5

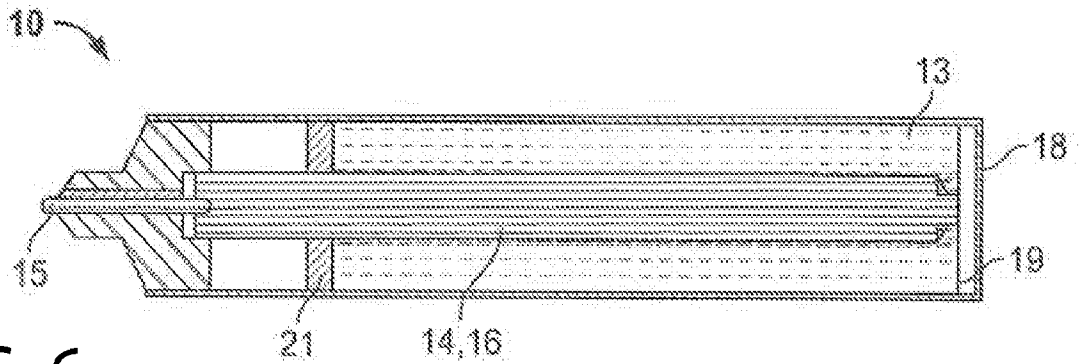

FIG. 6

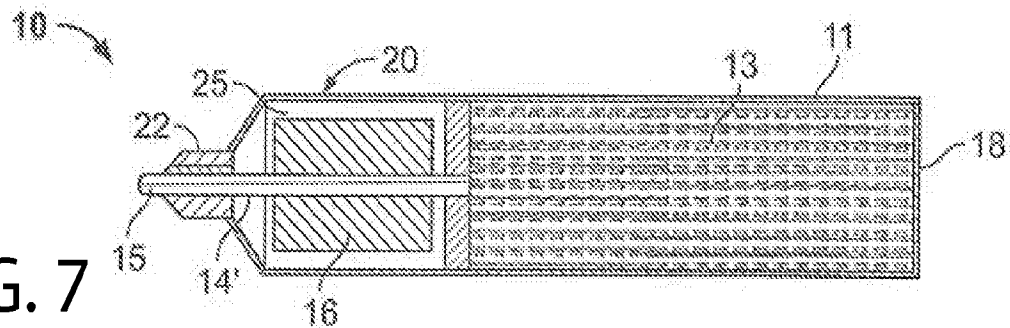

FIG. 7

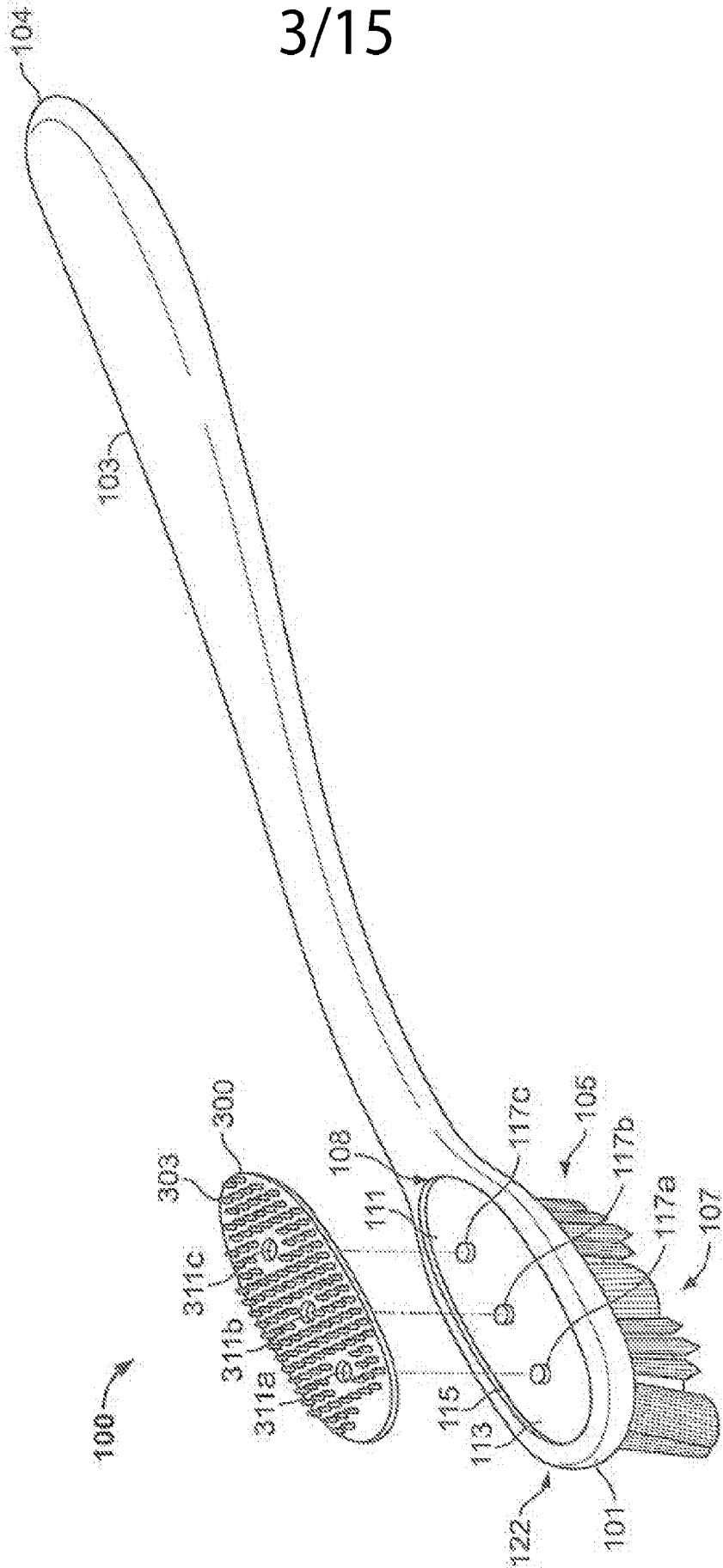

FIG. 8

4/15

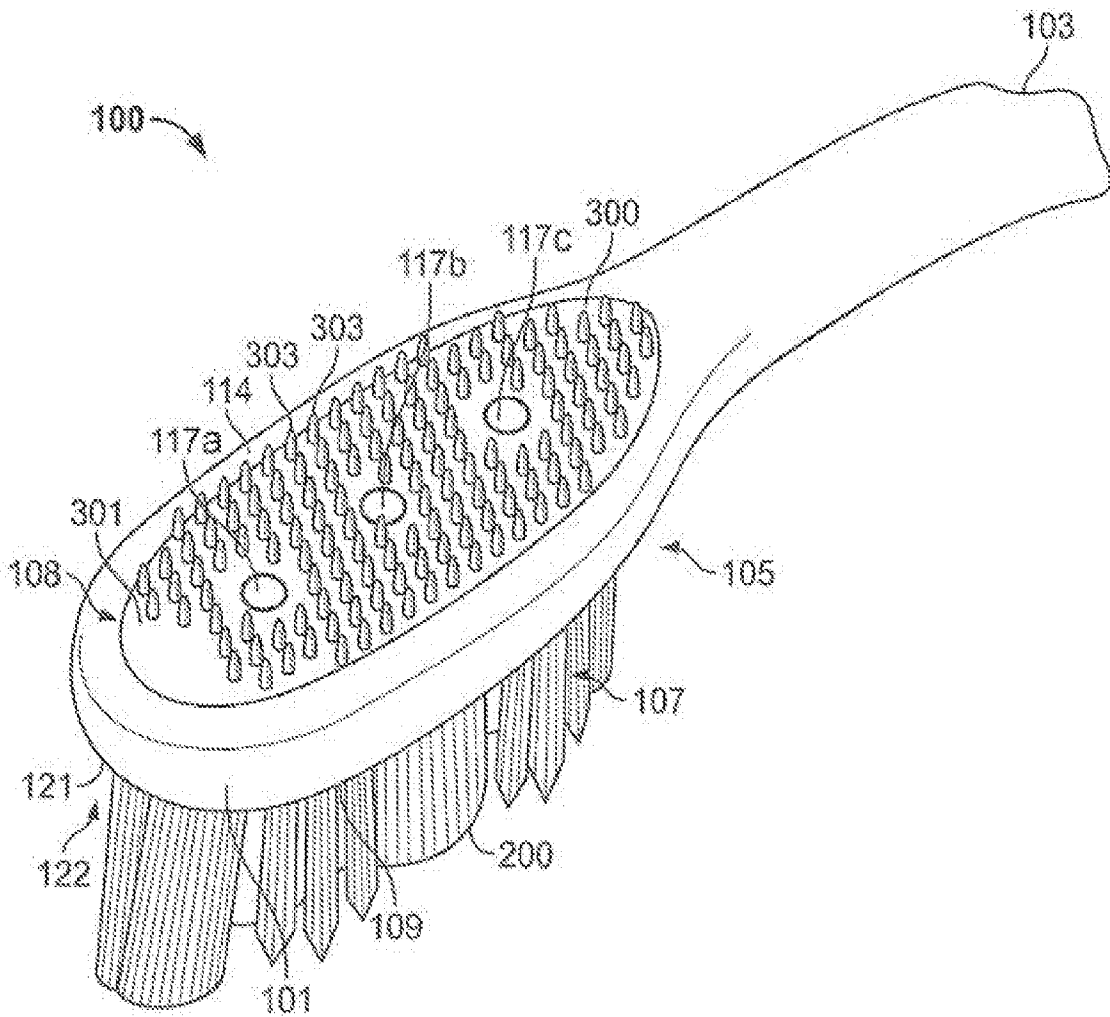

FIG. 9

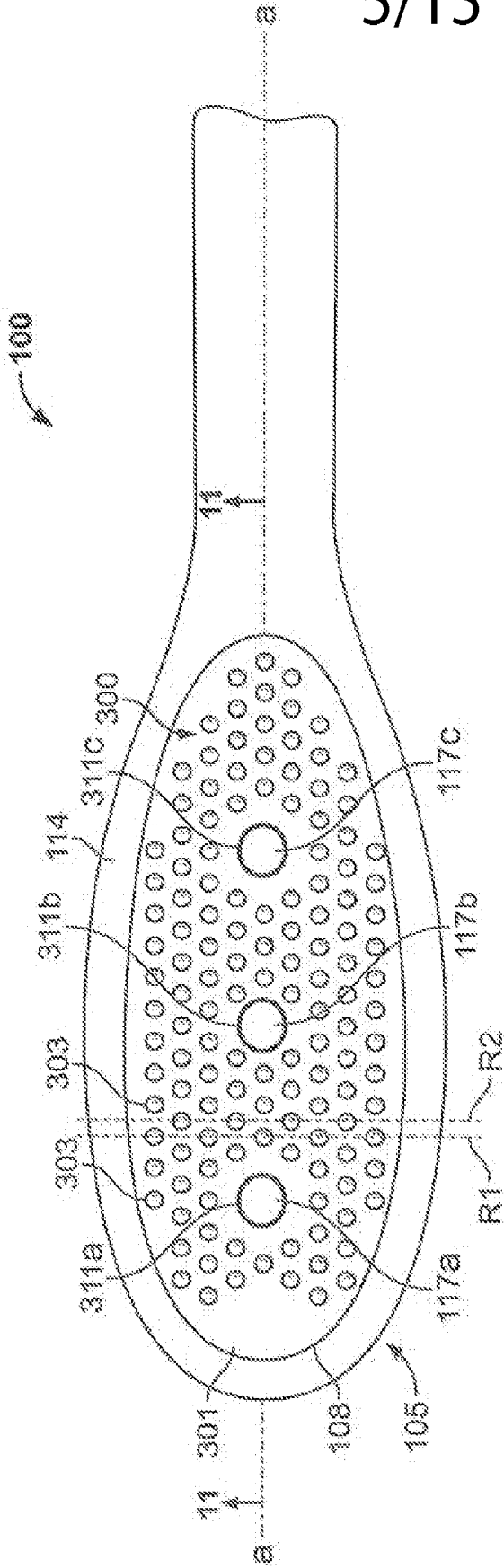

FIG. 10

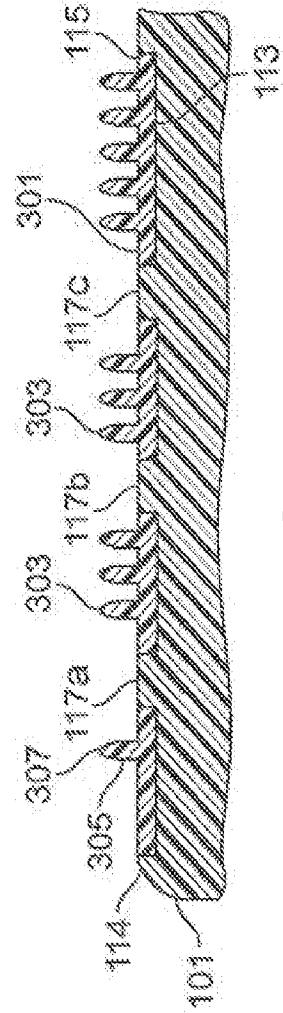

FIG. 11

6/15

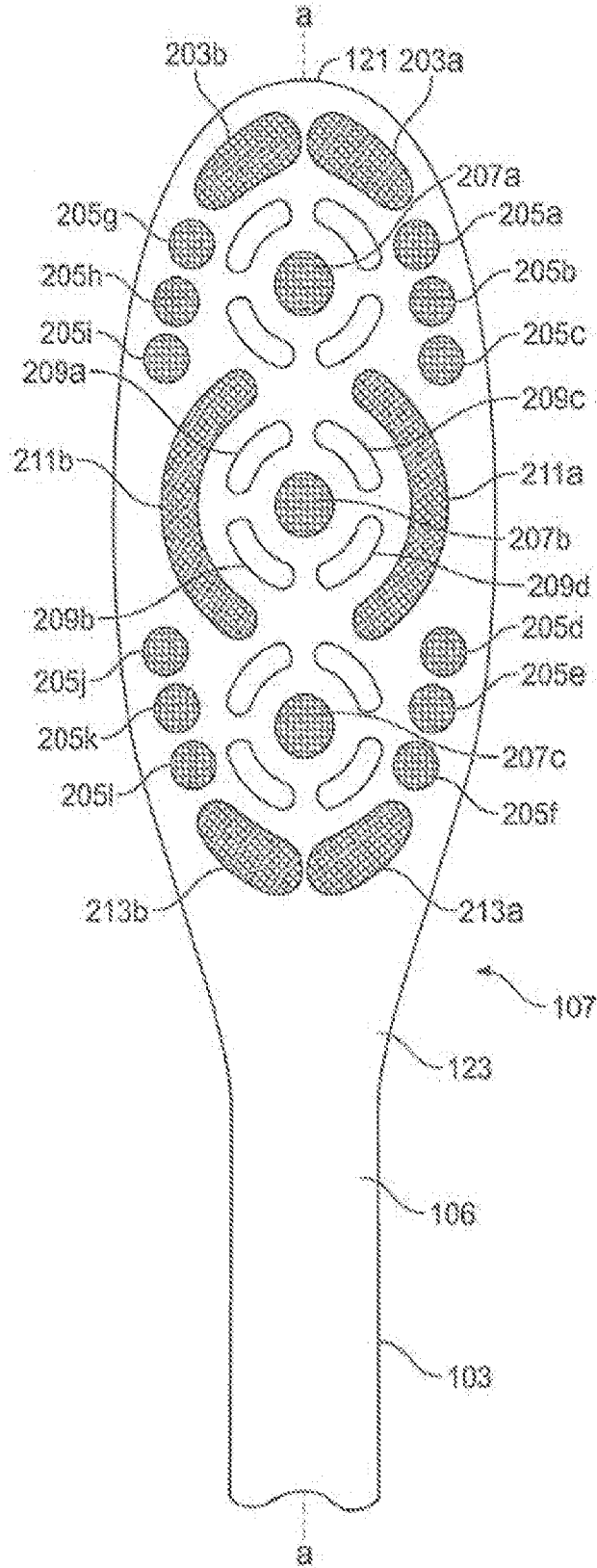

FIG. 12

7/15

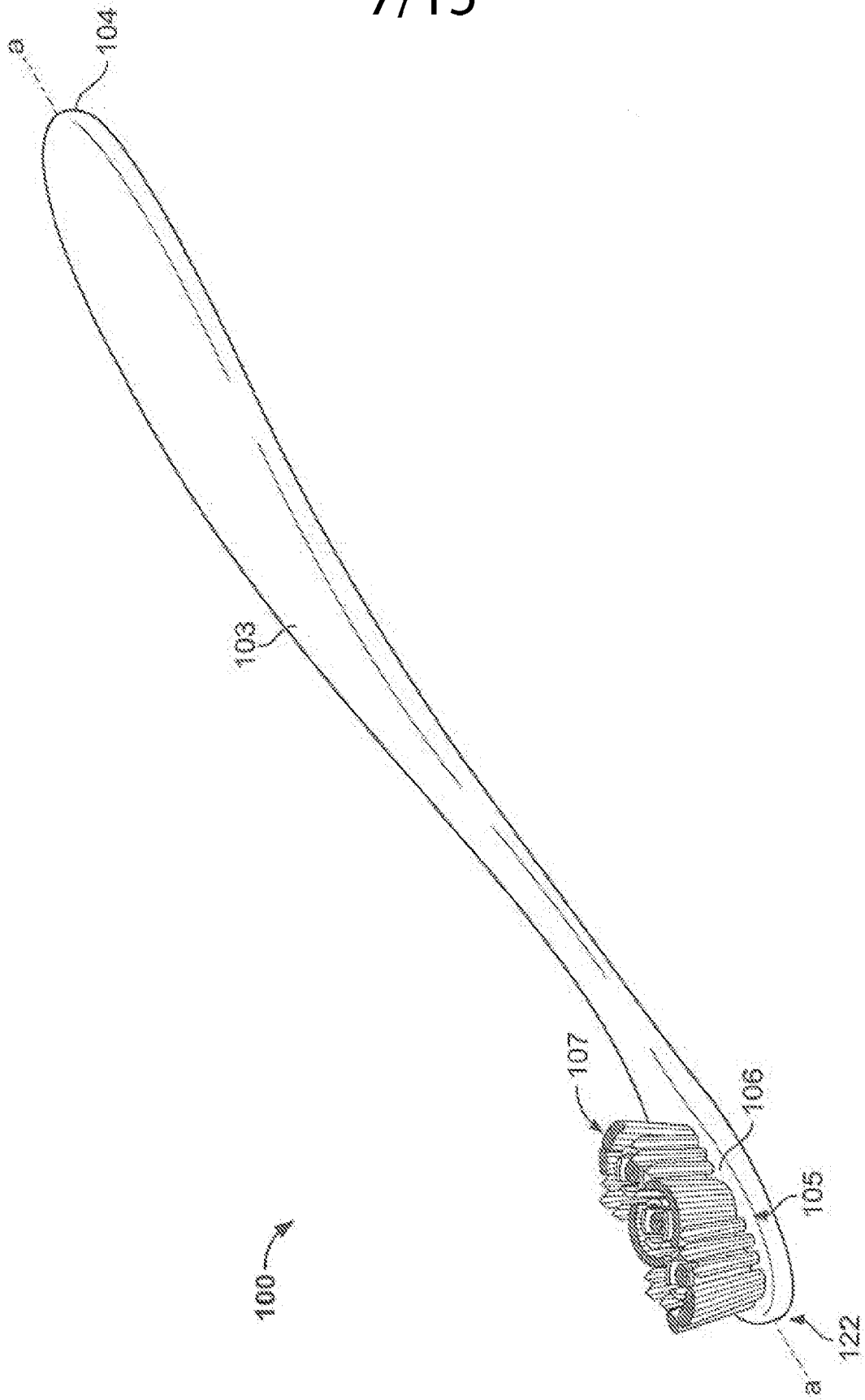

FIG. 13

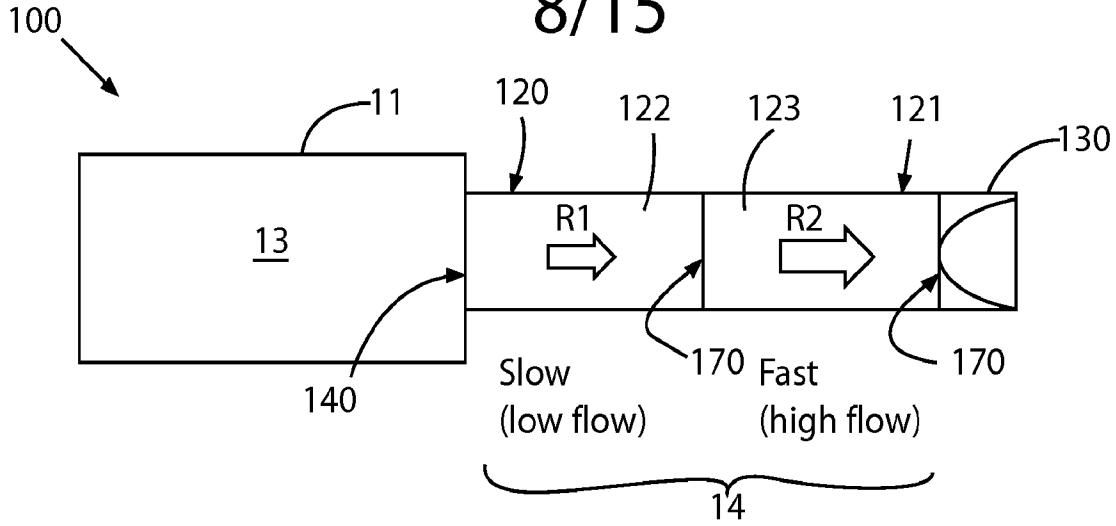

FIG. 14

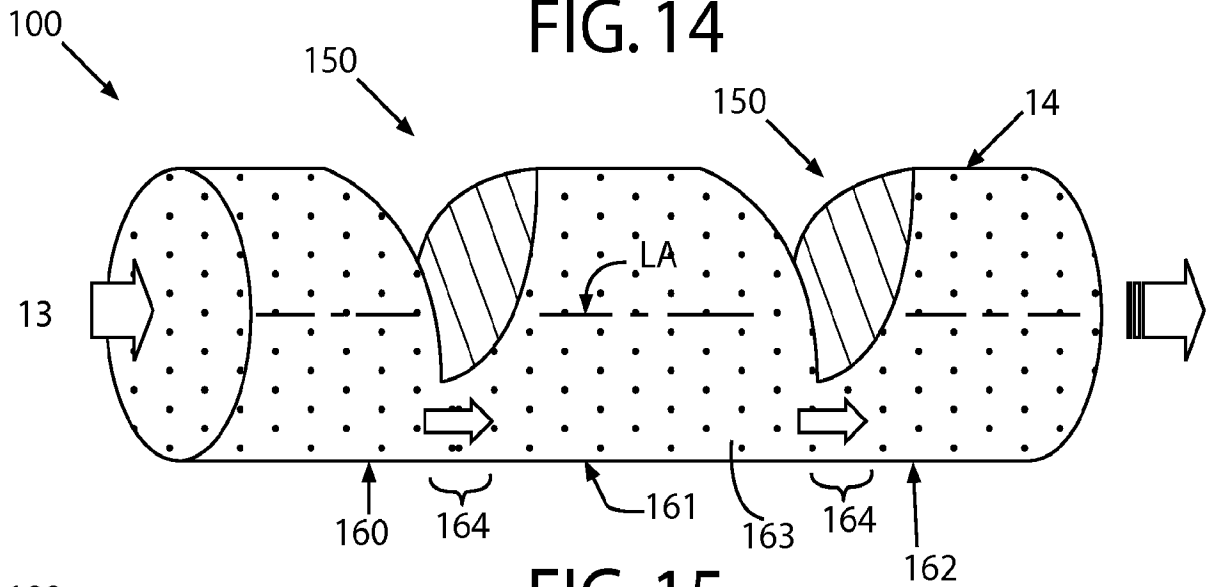

FIG. 15

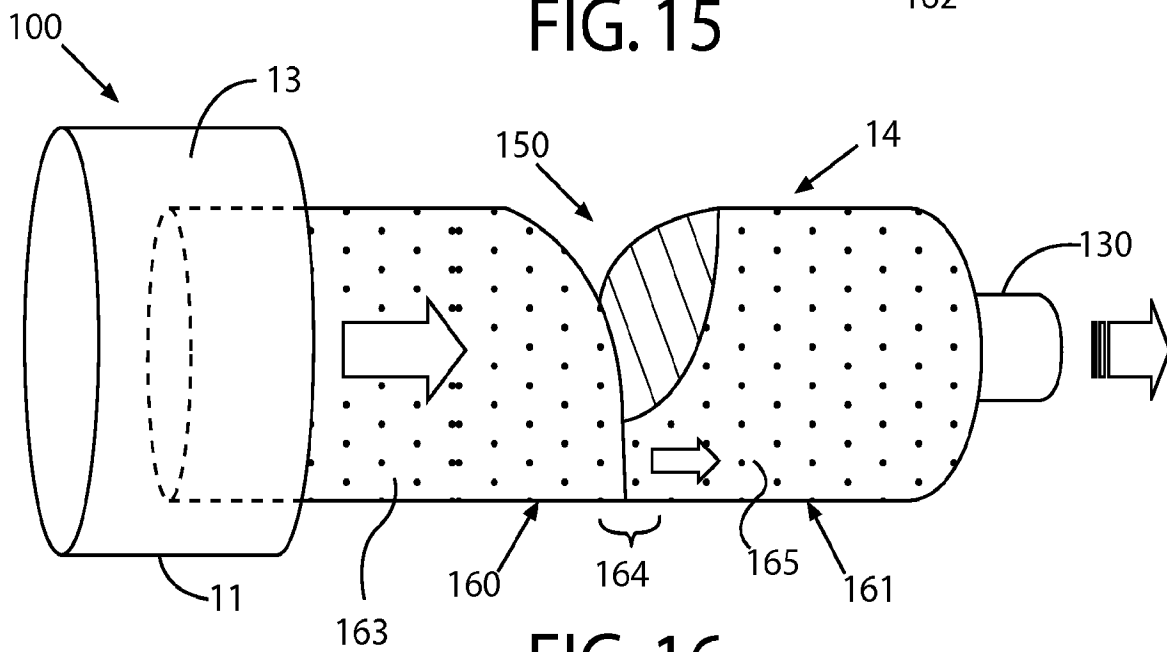

FIG. 16

9/15

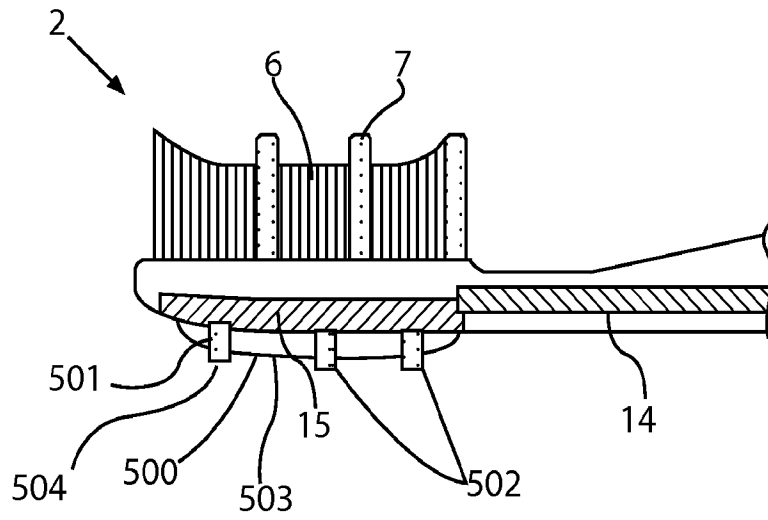

FIG. 17

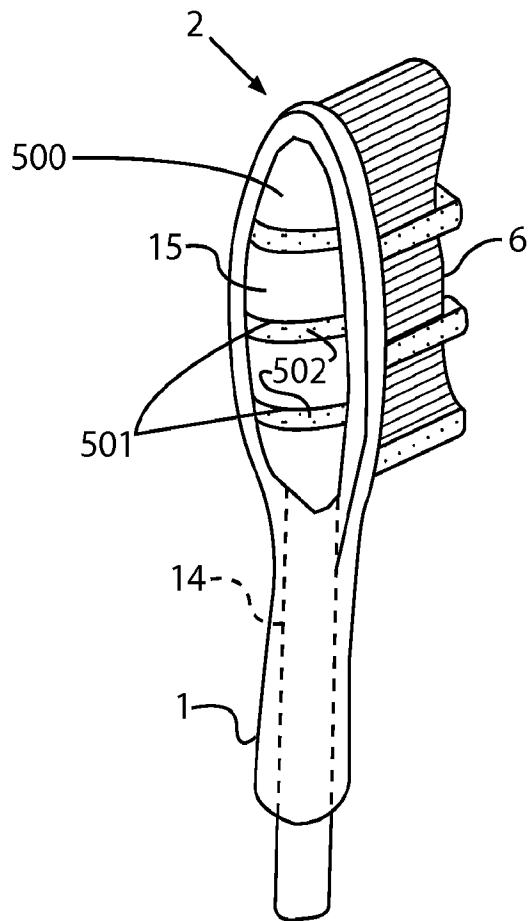

FIG. 18

10/15

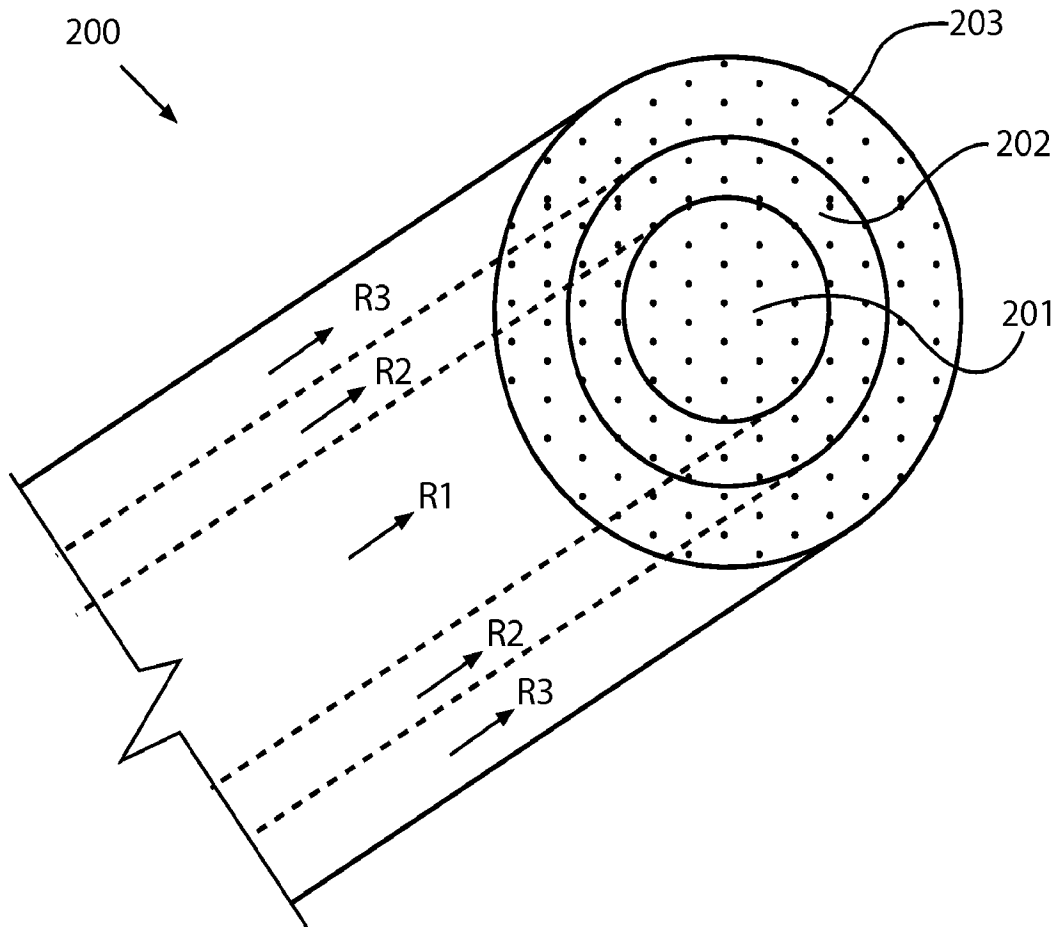

FIG. 19

11/15

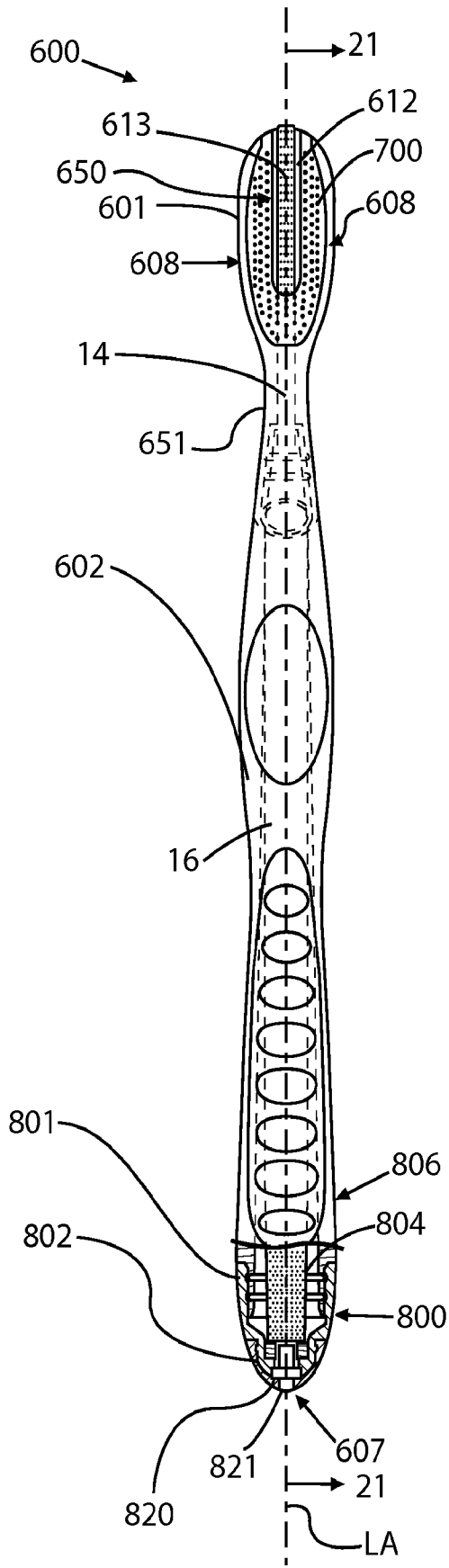

FIG. 20

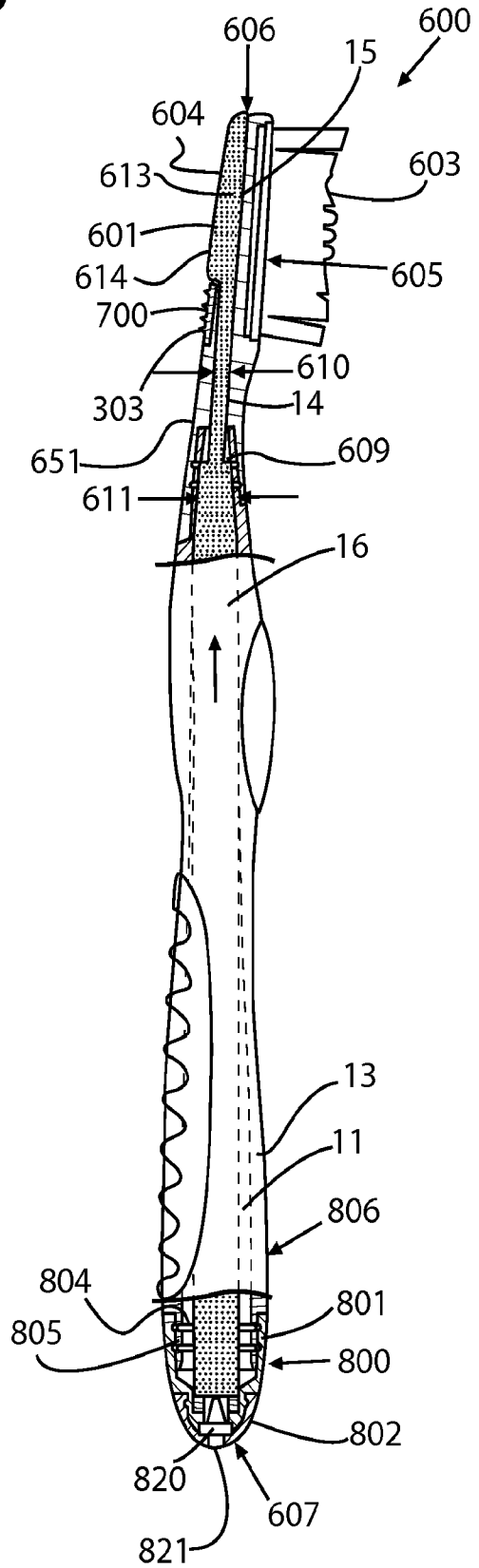

FIG. 21

12/15

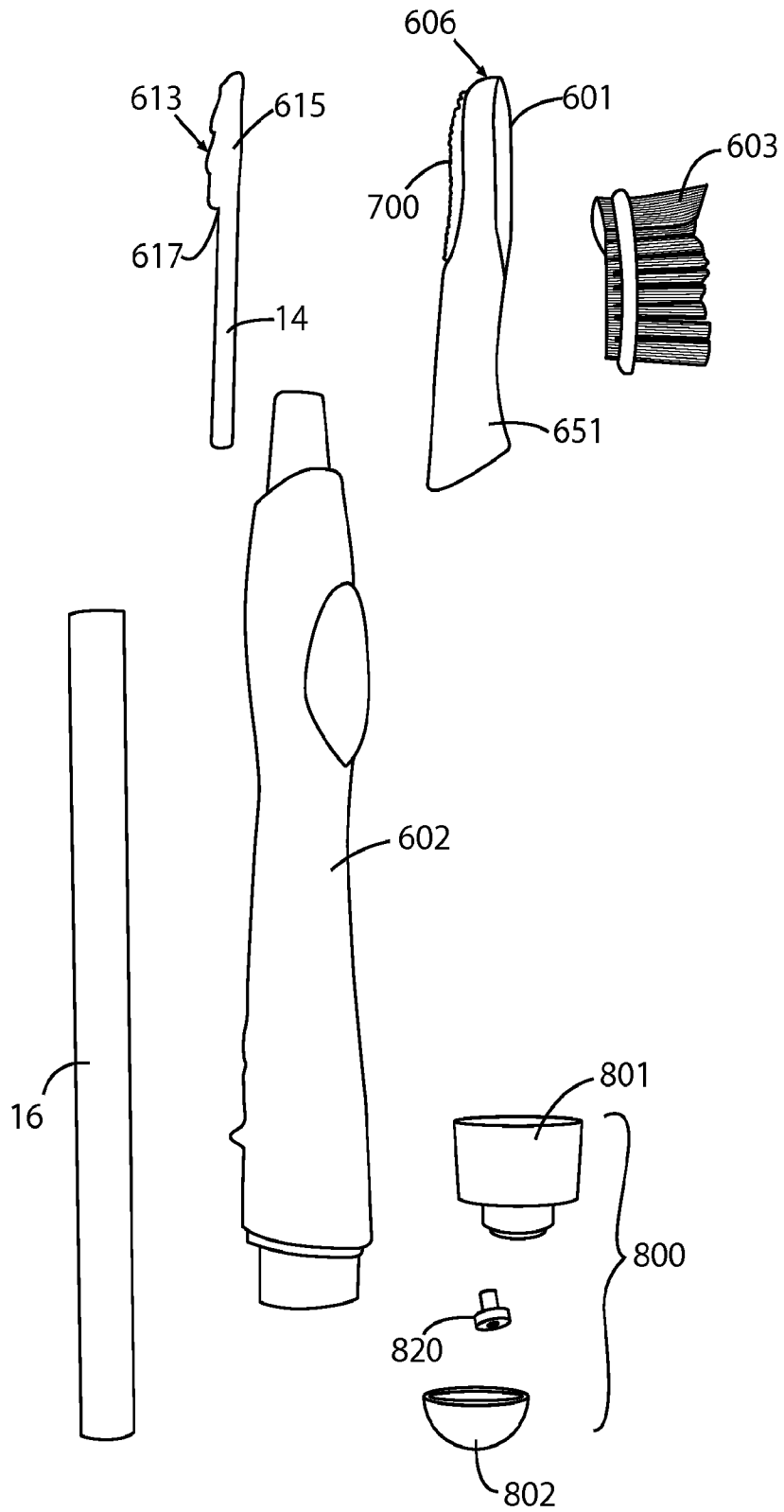

FIG. 22

13/15

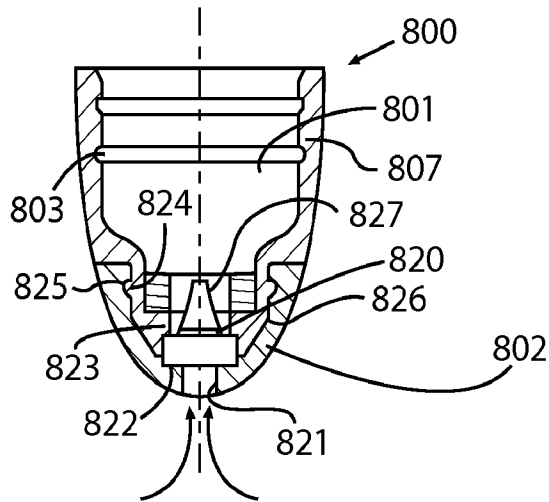

FIG. 23

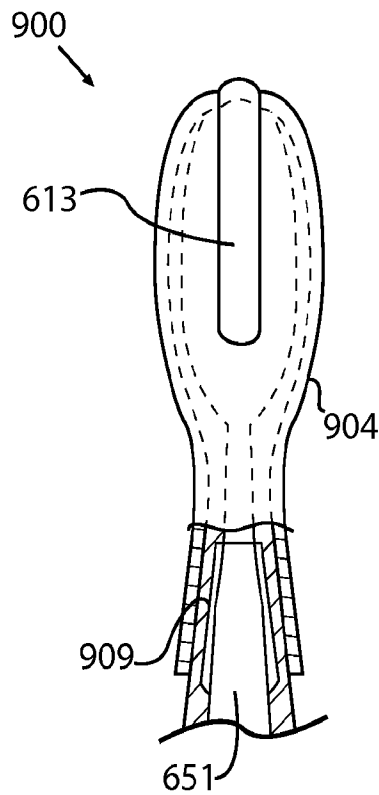

FIG. 24

14/15

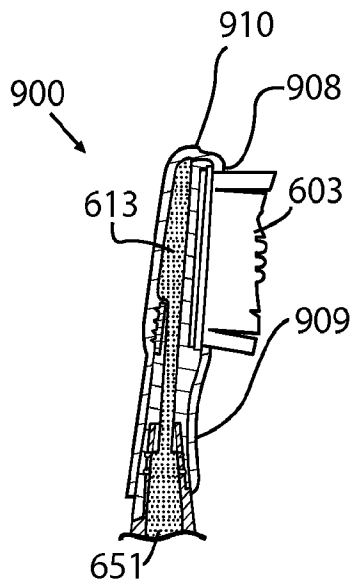

FIG. 25

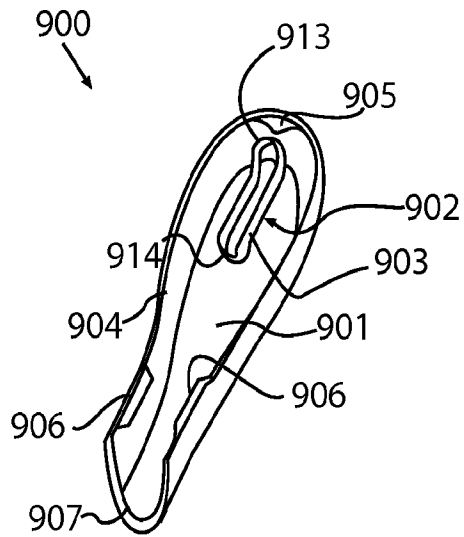

FIG. 26

15/15

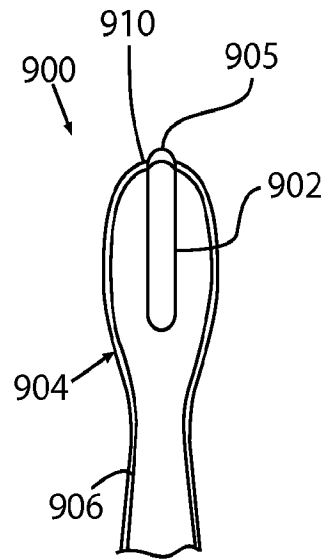

FIG. 27

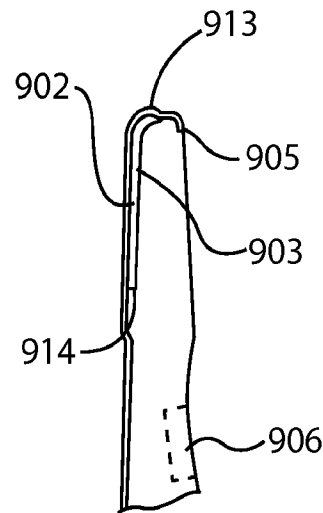

FIG. 28