

April 8, 1952

T. R. BLACK

2,592,002

ROOM VENTILATING APPARATUS

Filed July 30, 1948

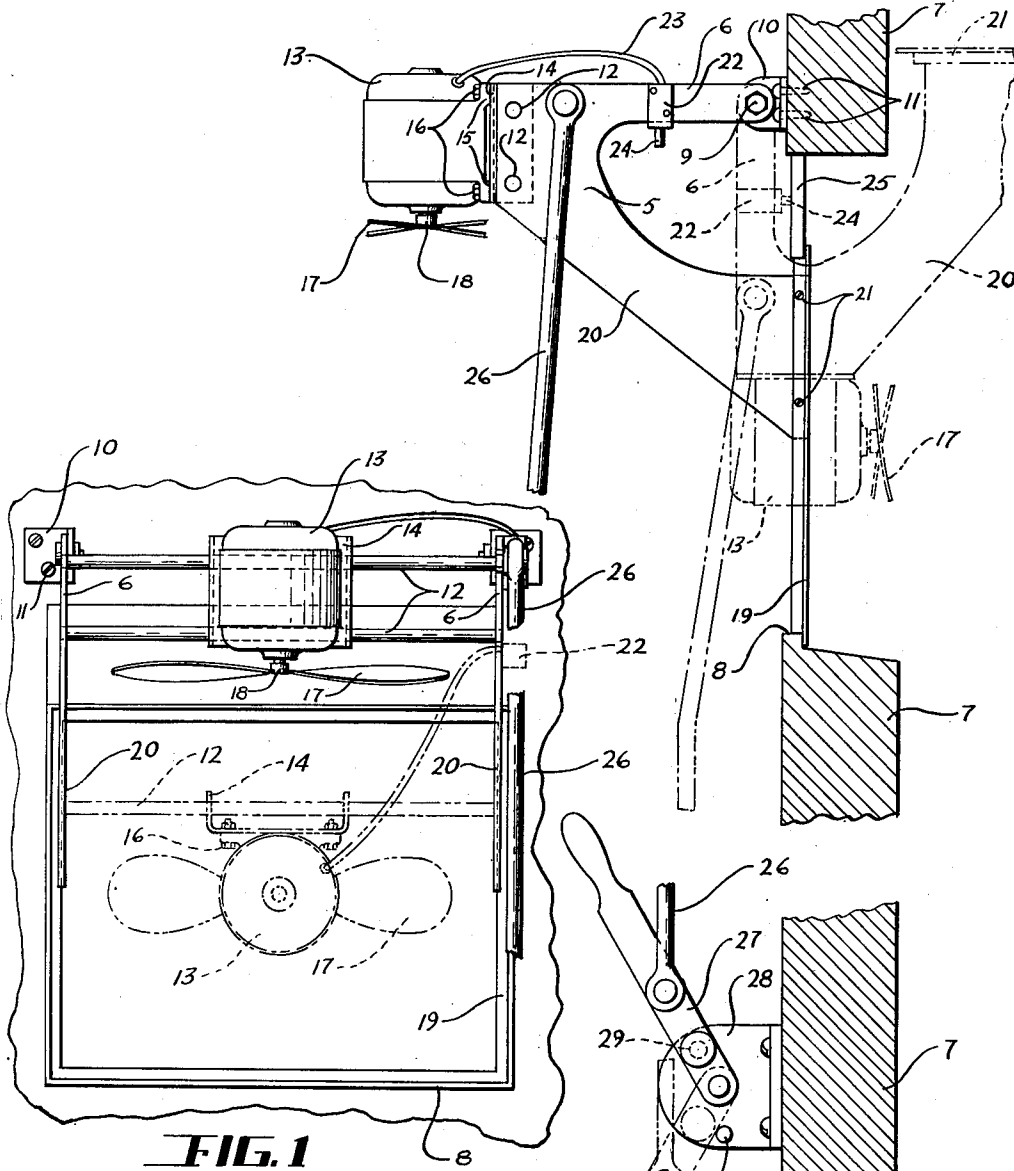

FIG. 1

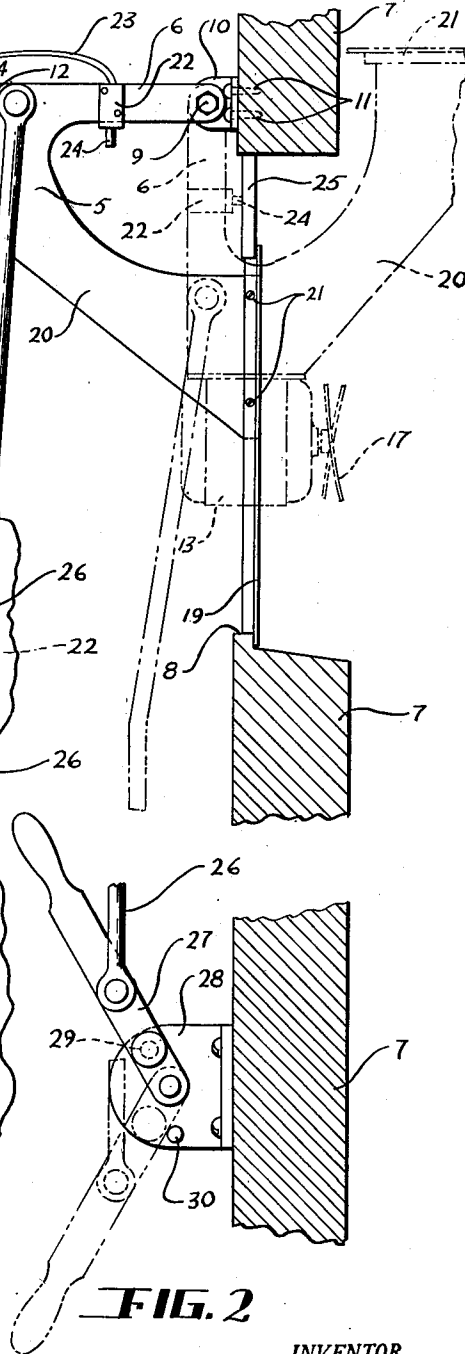

FIG. 2

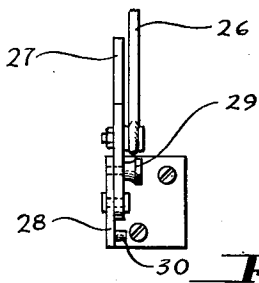

FIG. 3

INVENTOR.
THEODORE R. BLACK

BY

Carroll Hood
ATTORNEY

UNITED STATES PATENT OFFICE

2,592,002

ROOM VENTILATING APPARATUS

Theodore R. Black, Tipp City, Ohio

Application July 30, 1948, Serial No. 41,701

1 Claim. (Cl. 98—116)

1

This invention relates to a room ventilating apparatus, and one object of the invention is to provide a simple efficient apparatus for withdrawing air from a room or the like through a window or other opening, which may be moved to an inoperative position to permit the opening to be closed without dismantling the apparatus.

A further object of the invention is to provide such an apparatus which will automatically open the window when the apparatus is moved to operative position, and close the same when the apparatus is moved to inoperative position.

A further object of the invention is to provide such an apparatus including a motor operated fan the operation of which is automatically initiated as the fan is moved to operative position.

A further object of the invention is to provide such an apparatus with easily operated means for moving the same to and from its operative position and for positively retaining the same in said position.

A further object of the invention is to provide such an apparatus which can be easily installed in a room without substantial modification of the wall or window structure.

Other objects of the invention may appear as the apparatus is described in detail.

In the accompanying drawing Fig. 1 is a top plan view of an apparatus embodying the invention; Fig. 2 is a side elevation of such an apparatus with the wall in section; and Fig. 3 is a detail view of the locking device.

In these drawings I have illustrated one embodiment of my invention and have shown the same as comprising an air circulating device, such as an exhaust fan, carried by a movable supporting structure and movable into and out of a window to withdraw air from the room or other enclosure, the supporting structure being connected with the window closure to move the latter to its open or closed position as the fan is moved to or from its operative position. It is to be understood, however, that the apparatus may take various forms and may be applied to windows and window closures of various kinds without departing from the spirit of the invention. As hereinafter used the term "fan" is intended to include any suitable air circulating device by which air may be withdrawn from or discharged into an enclosure to be ventilated, and the term "window" is intended to include any suitable opening in a wall of such an enclosure.

In the particular embodiment here illustrated the supporting structure 5 comprises two lat-

2

erally spaced and preferably parallel arms 6 having means whereby they may be pivotally mounted on a wall 7 adjacent a window 8 in the wall. In the present instance the arms are provided at their inner ends, that is the ends adjacent the wall, with apertures adapted to receive aligned pivot pins 9 which are mounted in lugs 10 rigidly secured to the wall, as by screws 11. Preferably, but not necessarily, the supporting structure is mounted on the wall above the window for movement about a substantially horizontal axis. The outer ends of the arms 6 are rigidly connected one to the other, as by tie rods 12.

An electric motor 13 is supported on the outer portion of the supporting structure and in the present arrangement a flanged plate 14 is mounted on the rods 12 and the base 15 of the motor is rigidly secured to that plate, as by bolts 16. An exhaust fan 17 carried by the supporting structure is operatively connected with the motor and is here shown as mounted directly upon the motor shaft 18. The fan is spaced radially from the pivotal axis of the supporting structure such a distance that when that structure is moved about its pivotal axis toward the window the fan will be moved into a position in line with the window, that is, in a line extending through the window, that line being preferably, but not necessarily, at right angles to the wall in which the window is formed. Preferably the arms 6 are moved to a position substantially parallel with the wall and the motor 13 is supported partially within the window and the fan 17 is supported adjacent the outer side of the window and preferably within the latter.

The supporting structure has means whereby it may be connected with a closure for the window, such as an ordinary window sash 19, so that that closure will be moved to its open position as the supporting structure is moved toward the window and will be moved to its closed position as the supporting structure is moved to its uppermost or inoperative position. Preferably this means comprises laterally spaced and substantially parallel members or arms 20 rigidly secured at their outer ends to the outer portions of the respective arms 6, and in the present instance formed integral therewith, and extending downwardly and inwardly therefrom. At their free ends these arms are provided with means whereby they may be connected with the closure 19, as by bolts 21. The members 20 are of such vertical width and are so arranged that they move through the window 8 as the supporting

3

structure moves downwardly. In the present arrangement the closure or sash 19 is not directly connected with the wall 7 but is supported wholly by the members 20. Thus as the supporting structure moves the fan into alinement with the window the arms 20 move the closure bodily outwardly and upwardly to a substantially horizontal position, as shown in dotted lines in Fig. 2, and when the supporting structure and fan are returned to their inoperative positions the closure is moved into window closing position, as shown in full lines in Fig. 2.

The operation of the fan may be initiated in any suitable manner but preferably this is accomplished automatically and as here shown a normally open switch 22 of the push button or plunger type is mounted on one of the arms 6 and connected in the circuit 23 for the motor. The switch is so arranged that the plunger 24 thereof will contact the wall, or a part rigid therewith, as shown at 24, as the supporting structure completes its movement to operative position, thereby closing the switch and energizing the motor. Of course, as the supporting structure and fan are moved to their inoperative positions the plunger moves out of contact with the part 25 and the switch is automatically opened.

The supporting structure may be retained in the position to which it has been moved in any suitable manner. In the present arrangement an actuating rod 26 is pivotally connected with one side of the supporting structure and extends downwardly to a point below the window, in which position it is conveniently accessible for operation. Preferably the lower end of the rod is connected with an operating member, such as the lever 27 which in turn is pivotally mounted on a bracket 28 rigidly secured to the wall 7, the arrangement being such that the movement of the lever in an upward direction will move the supporting structure from its operative position to an inoperative position, and means are provided for locking the lever in a position to retain the supporting structure in the position to which it has been moved. This locking means may be of any suitable character and is here shown as a headed pin 29 adapted to extend through openings in the lever and the bracket and thus lock the lever. When the locking device is released the supporting structure will tend to move downwardly by gravity and a downward pull on the lever will move the same fully to its operative position, a stop 30 being pro-

4

vided to limit that movement. The locking pin 29 is then inserted in a lower opening in the bracket 28 as shown in dotted lines in Fig. 2 to firmly retain the supporting structure in its operative position.

While I have shown and described one embodiment of my invention I wish it to be understood that I do not desire to be limited to the details thereof as various modifications may occur to a person skilled in the art.

Having now fully described my invention what I claim as new and desire to secure by Letters Patent is:

A ventilating apparatus comprising laterally spaced arms having at adjacent ends thereof means whereby they may be pivotally mounted on a wall for movement about a common axis above an opening in said wall to a position extending outwardly from said wall or to a position substantially parallel with said wall, said arms being of such length that when parallel with said wall they terminate between the upper and lower edges of said opening, rods extending between and rigidly secured to the outer ends of said arms, a motor and fan mounted on said rods, other laterally spaced arms extending lengthwise of the first mentioned arms, rigidly connected at their outer ends with said first mentioned arms and extending downwardly and inwardly therefrom and through said opening, a closure plate for said opening carried by the free ends of the last mentioned arms and movable thereby into and out of a position to close said opening, a normally open switch in circuit with said motor, mounted on one of the first mentioned arms and having a member to engage a fixed part adjacent said opening and close said switch as said arm approaches said opening, and a manually actuated device for moving said structure about said pivotal axis and for retaining the fan in the position to which it has been moved.

THEODORE R. BLACK.

REFERENCES CITED

The following references are of record in the file of this patent:

UNITED STATES PATENTS

| Number | Name | Date |
|-----------|------------------|---------------|
| 1,788,556 | Wood et al. | Jan. 13, 1931 |
| 2,039,970 | McLaughlin | May 5, 1936 |
| 2,456,340 | Tideman | Dec. 14, 1948 |