



(11) **EP 2 130 683 B1**

(12) **EUROPEAN PATENT SPECIFICATION**

(45) Date of publication and mention of the grant of the patent:  
**05.12.2012 Bulletin 2012/49**

(51) Int Cl.:  
**B42F 7/02 (2006.01)**

(21) Application number: **09161554.2**

(22) Date of filing: **29.05.2009**

(54) **Variable size binder**

Verbinder mit variabler Größe

Reliure de taille variable

(84) Designated Contracting States:  
**AT BE BG CH CY CZ DE DK EE ES FI FR GB GR HR HU IE IS IT LI LT LU LV MC MK MT NL NO PL PT RO SE SI SK TR**

(30) Priority: **04.06.2008 IT BO20080350**

(43) Date of publication of application:  
**09.12.2009 Bulletin 2009/50**

(73) Proprietor: **Frati E Livi S.r.l.**  
**40013 Castel Maggiore (Bologna) (IT)**

(72) Inventor: **Livi, Pietro**  
**40056 Crespellano (Bologna) (IT)**

(74) Representative: **Lanzoni, Luciano**  
**Bugnion S.p.A.**  
**Via di Corticella, 87**  
**40128 Bologna (IT)**

(56) References cited:  
**DE-A1- 19 620 506 DE-A1- 19 735 383**  
**FR-A- 2 082 000 FR-A- 2 524 391**  
**GB-A- 2 406 076**

**EP 2 130 683 B1**

Note: Within nine months of the publication of the mention of the grant of the European patent in the European Patent Bulletin, any person may give notice to the European Patent Office of opposition to that patent, in accordance with the Implementing Regulations. Notice of opposition shall not be deemed to have been filed until the opposition fee has been paid. (Art. 99(1) European Patent Convention).

## Description

**[0001]** The object of the present invention is a binder, and in particular a binder of the type so-called "folder" used for filing documents and suitable for exhibiting a variable outer size based on the amount of documents contained therein.

**[0002]** Variable size binders are known, defined by a rough shape of flexible cardboard suitably folded for defining a box shaped container as one substantially described in FR 2 082 000. The rough shape exhibits a central square or rectangular wall suitable for defining a bottom of the binder, and four wings arranged at the sides of the central wall for defining as many side walls cross the bottom wall. One of the four wings exhibits a larger size for defining a top wall of the binder as well and for overlapping at least partly on the opposite wing so as to completely enclose the space within the binder. The top wall and the opposite wing can also be connected to one another by press buttons or by strings to tie.

**[0003]** Disadvantageously, this type of binder is scarcely adaptable to variable amounts of documents. In the case of filing of few documents, the side walls take a reduced thickness while an excessive surface of the top wall is created, which must be folded more around the opposite wing. This creates a greater difficulty for closing the binder and may make it impossible to close it by the above buttons or strings due to the lack of alignment between the top wall and the opposite wing.

**[0004]** Moreover, the greater folding of the top wall may lead the latter to be easily subject to risks of damages or even cracks.

**[0005]** On the other hand, in the case of an excessive amount of documents to be filed, the side walls take a large thickness while a reduced or even insufficient overlapping is created between the top wall and the opposite wing. In this case, the insufficient overlapping may leave a part of the underlying documents exposed. Moreover, also in this circumstance the lack of alignment between the top wall and the opposite wing may make the reciprocal connection by the buttons or strings difficult, if not impossible.

**[0006]** In both the above situations, the binders of the prior art therefore are not very suitable for receiving an amount of documents differing from a precise predetermined value, exhibiting a considerable inconvenience of use related above all to the impossibility of properly closing the binder and having the latter take a configuration suitable for being inserted in an archive, for example on a shelf.

**[0007]** One example of other kind of binder is disclosed in FR 2 524 391, which discloses the features of the preamble of claim 1.

**[0008]** Such binder presents an extensible panel, defined by a pocket, for varying surface extension to adapt the overall size of the binder to the size of the documents contained therein.

**[0009]** Another kind of variable capacity folder or wallet

is disclosed in GB 2 406 076. The disclosed folder comprises sliding joint between juxtaposed panels which form opposite pocket sides.

**[0010]** In DE 196 20 506 is showed a folder for papers having a cover and a base joined together by a back, where the width of the back can be altered to accommodate the height of the stack of papers.

**[0011]** A binder having an unfolded front sheet and a rear sheet with a folded over edge along the binding side is disclosed in DE 197 35 383.

**[0012]** The technical task of the present invention is to solve the problems found in the prior art by providing a variable size binder capable of solving the problems mentioned above.

**[0013]** In particular, the object of the present invention is to provide a variable size binder which should exhibit a high convenience of use.

**[0014]** A further object of the present invention is to provide a variable size binder which should be adaptable to different amounts of documents to be filed.

**[0015]** A further object of the present invention is to provide a variable size binder which should exhibit a high sturdiness.

**[0016]** These and yet other objects, as will better appear hereinafter in the following description, are achieved by a variable size binder comprising the features expressed in one or more of the annexed claims.

**[0017]** Further features and advantages will appear more clearly from the detailed description of a preferred but non-exclusive embodiment of a variable size binder according to the present invention. Such description will be made hereinafter with reference to the annexed drawings, provided by way of a non-limiting indication only, wherein:

- figure 1 shows a perspective view of a binder according to the present invention in a spread configuration;
- figures 2A and 2B show a perspective view of the binder of figure 1 in two different custom configurations;
- figures 3A and 3B show a cutaway view of the binder shown, respectively, in figures 2A and 2B in corresponding operating configurations;
- figure 4 shows a perspective view of the binder of figure 1 in an exploded configuration and in accordance with an embodiment version;
- figure 5 shows a perspective view of the binder of figure 1 in a closed configuration;
- figure 6 shows a third embodiment of a binder according to the present invention in a schematic perspective view in open configuration.

**[0018]** According to the annexed figures, reference numeral 1 globally denotes a variable size binder according to the present invention. It is noted that the wording "variable size" takes into account that such binder is suitable for enclosing an amount of documents so that the overall

size of the binder is substantially equal to the size of the documents contained therein, and in particular is reduced in the case of few documents contained.

**[0019]** Binder 1 is partly obtained by bending a rough shape 2 having a central rectangular or square panel and four wings that extend from the four side edges of the central panel. Said central panel defines a bottom wall 3 of binder 1, suitable for contacting a face of the documents included in binder 1, whereas said wings respectively define a first, a second, a third and a fourth side wall of binder 1, respectively indicated with reference numerals 4, 5, 6, 7. Said side 4, 5, 6, 7 and bottom 3 walls therefore define an outer enclosure for containing the material to be filed and suitable for taking an open configuration (figures 1, 2A, 2B), wherein it can receive the material to be filed or allow taking the material filed therein, and a closed configuration (figure 5) wherein it can be arranged on a shelf or other place suitable for the storage thereof.

**[0020]** The first side wall 4 exhibits an edge 4a connected to the bottom wall 3 and defining a folding line of the first side wall 4 relative to the bottom wall 3. Likewise, the other walls 5, 6, 7 exhibit respective edges 5a, 6a, 7a defining as many folding lines of said side walls 5, 6, 7 relative to the bottom wall 3.

**[0021]** Each side wall 4, 5, 6, 7 is therefore suitable for folding on the bottom wall 3 around the respective edge 4a, 5a, 6a, 7a that connects it to the bottom wall 3 so that a space "S" is defined between the side walls 4, 5, 6, 7 and the bottom wall 3 wherein the material "M" to be filed is received. By way of an example, material "M" to be filed may consist of a package of sheets, documents, catalogues or other paper or plastic material suitable for filing into folders.

**[0022]** Preferably, the side walls 4, 5, 6, 7 exhibit a plurality of pre-weakening lines 4b, 5b, 6b, 7b parallel to edges 4a, 5a, 6a, 7a. Such pre-weakening lines 4b, 5b, 6b, 7b allow a simple and practical folding of each side wall 4, 5, 6, 7 around material "M" present in said space "S" thus avoiding irritating bends that would oppose a proper closing of binder 1.

**[0023]** Thanks to the pre-weakening lines 4b, 5b, 6b, 7b, the side walls 4, 5, 6, 7 may be folded easily for taking right angle edges so as to make binder 1 take a substantially box shaped outer shape.

**[0024]** The first wall 4 and the second wall 5 are arranged in a position opposite each other, that is, they are connected to respective opposite sides of said central rectangular panel. The first and the second wall 4, 5 cooperate with each other for defining a side and top closure of binder 1.

**[0025]** Likewise, the third wall 6 and the fourth wall 7 are also arranged in a position opposite each other relative to the central panel. The third and the fourth wall 6, 7 cooperate with each other for defining a side closure of binder 1.

**[0026]** In this way, said space "S" is substantially closed and delimited both laterally and at the top, where-

as at the bottom it is delimited by the bottom wall 3.

**[0027]** Advantageously, the first side wall 4 is extensible along a direction of approach and removal relative to the corresponding edge 4a. More in detail, the first side wall 4 is extensible for varying its surface extension so as to align with the bottom wall irrespective of the amount of material to be filed included within said space "S". By the term alignment it is meant the overlapping between the outer perimeter of the first side wall 4 and the outer perimeter of the bottom wall 3.

**[0028]** Going into further detail, the first side wall 4 comprises a first portion 8, directly connected to the bottom wall by said edge 4a and provided with the pre-weakening lines 4b, and a second portion 9 substantially shaped as an envelope and fitted on the first portion 8 at an end of the latter opposite said edge 4a. The second portion 9 is fitted on the first portion 8, that is, the first portion 8 is inserted in a front opening "A" of the second portion 9, so that the second portion 9 is movable in approach and in removal relative to the respective edge 4a. Preferably, said first and second portion 8, 9 have a surface extension substantially equal to the surface extension of the bottom wall 3. In this way, the first side wall 4 is extensible between a minimum extension configuration (figures 2B and 3A), wherein the first portion 8 is entirely inserted into the second portion 9 for defining an overall extension substantially equal to the bottom wall 3, and a maximum extension configuration (figures 2A and 3B), wherein the first portion 8 is almost entirely extracted from the second portion 9 for defining an overall extension substantially equal to twice the bottom wall 3.

**[0029]** The second portion 9 may therefore always be above the bottom wall 3 and aligned with the latter, since it is possible to act by increasing or decreasing the insertion of the first portion 8 into the second portion 9 based on a larger or smaller thickness of material "M" included within space "S".

**[0030]** Advantageously, moreover, there are provided fixing means 10 active between the first and the second portion 8, 9 for steadily locking the second portion 9 relative to the first portion 8 at a plurality of predetermined configurations. The fixing means 10 are of the releasable type for allowing the modification of the positioning of the second portion 9 relative to the first portion 8, in particular when it is necessary to vary the amount of material "M" filed within space "S".

**[0031]** Figure 1 shows a first embodiment of binder 1, wherein the fixing means 10 comprise a pair of buttons 11 fixed to the second portion 9, and a plurality of second buttons 12 fixed to the first portion 8 and which can be connected snap-wise with the first buttons 11. Said second buttons 12 are arranged in an aligned configuration along the sliding direction of the second portion 9 on the first portion 8, preferably on two parallel rows.

**[0032]** Advantageously, in alternative embodiments, buttons 11 and 12 are arranged according to a respective row in a median portion of the second portion 9 and of the first portion 8 of wall 4.

**[0033]** Figure 4 shows a second embodiment of binder 1, wherein the fixing means 10 comprise a connection with Velcro® having a pair of strips 13 fixed on the first portion 8 in alignment along the sliding direction of the second portion 9 on the first portion 8, and a pair of gripping elements 14 fixed to the second portion 9 and steadily engageable each with a corresponding strip 13.

**[0034]** According to what shown in figure 6, the fixing means 10 are defined by a pair of tabs 15 hinged to portion 9 of wall 4.

**[0035]** Tabs 15 are each provided with an adhesive element 16 arranged on the inner surface thereof or facing portion 8 of wall 4 for attaching thereon.

**[0036]** Preferably, button 11 and/or gripping elements 14 and/or tabs 15 are arranged in the proximity of an end of the second portion 9 facing the respective edge 4a, that is, at said front opening "A".

**[0037]** Binder 1 comprises one or more strings that can be tied to each other having the function of steadily coupling two parts of binder 1 to each other. As an alternative, the same parts are steadily coupled to each other by snap-wise connections, according to alternative embodiments not shown.

**[0038]** With particular reference to figures 1, 2 and 4 it is noted that a first string "L1" is provided to cross the bottom wall 3 through a first and a second hole 31 and 32.

**[0039]** The same string L1 is then inserted into portion 9 of wall 4 entering into the same through a hole 91 and coming out thereof through a hole 92; in the practice, string L1 thus passes inside space "S" when binder 1 is closed.

**[0040]** Advantageously, string L1 is fixed to portion 9 within the same.

**[0041]** Preferably, string L1 has a development at least coinciding with a corresponding outer peripheral development of binder 1 in a maximum extension configuration, as schematically shown in figure 5.

**[0042]** As an alternative, in a solution not shown, the fixing means 10 comprise a pair of strings "L1" of which a first one associated to the bottom wall 3 and which extends towards wall 5 and a second one associated to an end of the second portion 9 opposite relative to the front opening "A", that is, the free end of the second portion 9; in this way, strings L1 may be tied to one another with binder 1 closed.

**[0043]** A pair of strings "L2" is preferably provided at the third and fourth side wall 6, 7. Strings L2 are fixed to the bottom wall 3 and extend towards the side walls 6, 7.

**[0044]** A first and a second string "L3" extend from the side wall 4, in particular from the second portion 9 of the side wall 4, crosswise relative to the direction of insertion of portion 9 on portion 8.

**[0045]** Each string L2 is positioned relative to a corresponding string L3 so as to tie therewith in the closed configuration of binder 1 shown in figure 5, so as to keep the bottom wall 3 and the second portion 9 of the first wall 4 close.

**[0046]** Preferably, said bottom wall 3 is defined by a

pair of sheets overlapped to each other for withstanding the strains due to said strings L1, L2 and L3.

**[0047]** Preferably, binder 1 is made of cardboard.

**[0048]** The present invention attains the proposed objects, overcoming the disadvantages mentioned in the prior art.

**[0049]** The provision of a side wall having a first and a second portion contiguous to each other and connected in a telescopic manner for overlapping according to a plurality of different operating configurations allows varying the geometry of the binder and allowing the adaptation of the same to different sizes of the material filed therein. Each of the above different operating configurations in fact allows a different overall surface extension of the first side wall, which can therefore be adapted for allowing a same alignment between the first side wall and the bottom wall irrespective of the amount of material to be filed included in the binder.

**[0050]** The configuration achieved by the binder (figure 5), on the other hand, is easily closable and very sturdy and compact due to the box shape taken by the binder itself.

**[0051]** The fixing means and the strings further allow keeping the configuration thus obtained steadily, which allows the binder to be handled safely.

**[0052]** Advantageously, moreover, the binder according to the invention may contain documents without needing any permanent modifications and/or interventions to the documents themselves, such as for example punching needed for filing into ring binders of the

prior art.

## 35 Claims

1. A binder comprising an outer enclosure suitable for taking an open configuration and a closed configuration and internally defining a space (S) for receiving material (M) to be filed, said enclosure exhibiting a bottom wall (3) and at least a first wall (4) having an edge (4a) connected to the bottom wall (3) and suitable for arranging above the bottom wall (3) in said closed configuration of the enclosure; said first wall (4) being extensible for varying a surface extension thereof so as to allow a same alignment between said first wall (4) and said bottom wall (3) irrespective of the amount of material to be filed included within said space (S), said first wall (4) comprising a first portion (8) and a second portion (9) connected to each other in a telescopic manner, said first portion (8) and second portion (9) being contiguous to one another and at least partly overlappable to one another according to a plurality of different operating configurations, each operating configuration defining a respective surface extension of the first wall (4), said first portion (8) exhibiting said edge (4a) connected to the bottom wall (3), said second portion

- (9) exhibiting an envelope shape for being slidably fitted on said first portion (8) at an end of said first portion (8) opposite said edge (4a), the binder being **characterised in that** it comprises fixing means (10) active between the first and the second portion (8, 9) for steadily fixing the second portion (9) relative to the first portion (8) at a plurality of predetermined configurations, said fixing means (10) being releasable for allowing a modification of the positioning of the second portion (9) relative to the first portion (8).
2. The binder according to claim 4 1, **characterised in that** said second portion (9) exhibits a surface extension substantially equal to the surface extension of the first portion (8).
  3. The binder according to claim 1, **characterised in that** said second portion (9) exhibits a surface extension substantially equal to the surface extension of the bottom portion (3).
  4. The binder according to one or more of claims 1 to 3, **characterised in that** said first wall (4) is extensible for taking a minimum extension configuration, wherein said first portion (8) is entirely inserted into said second portion (9) for defining an overall extension substantially equal to the bottom wall (3), and a maximum extension configuration, wherein the first portion (8) is at least partly extracted from the second portion (9) for defining an overall surface extension greater than the bottom wall (3).
  5. The binder according to claim 1, **characterised in that** said fixing means (10) comprise at least a first element (11) fixed to said second portion (9), and a plurality of second elements (12) fixed to said first portion (8) and which can be connected snap-wise with said first element (11); said second elements (12) being arranged in alignment along a sliding direction of the second portion (9) on the first portion (8).
  6. The binder according to claim 1, **characterised in that** said fixing means (10) comprise a connection with Velcro®, said connection comprising at least one strip (13) fixed to said first portion (8) and oriented in alignment along a sliding direction of the second portion (9) on the first portion (8), and at least one gripping element (14) fixed to said second portion (9) and steadily engageable with said strip (13).
  7. The binder according to claim 1, **characterised in that** it comprises at least one releasable closure, active between said second portion (9) of the first wall (4) and said bottom wall (3) for obtaining a steady and reversible closure of the binder (1).
  8. The binder according to one or more of the foregoing claims, **characterised in that** said first wall (4) exhibits respective pre-weakening lines (4b) parallel to said edge (4a) and defining respective folding lines for adapting the first wall (4) to the outer shape of the material (M) to be filed contained in said space (S).
  9. The binder according to one or more of the foregoing claims, **characterised in that** it comprises a second wall (5) connected to the bottom wall (3) opposite relative to said edge (4a) of the first wall (4) and cooperating with said first wall (4) for obtaining a side closure of the binder (1).
  10. The binder according to claim 9, **characterised in that** it comprises a third and a fourth wall (6, 7), connected to the bottom wall (3) and arranged in opposite position relative to each other, said third and fourth wall (6, 7) being arranged crosswise said first and second wall (4, 5) for completing a side closure of the binder (1).
  11. The binder according to claim 9 or 10, **characterised in that** said second wall (5) and/or said third and fourth wall (6, 7) exhibit respective pre-weakening lines (5b, 6b, 7b) defining respective folding lines for adapting to the outer size of the material (M) to be filed contained in said space (S).
  12. The binder according to one or more of the foregoing claims, **characterised in that** it is made of cardboard.
- ### 35 Patentansprüche
1. Ordner, umfassend eine äußere Umhüllung, die zum Einnehmen einer offenen Konfiguration und einer geschlossenen Konfiguration geeignet ist und innen einen Raum (S) zur Aufnahme von abzulegendem Material (M) definiert, wobei die Umhüllung eine untere Wand (3) und mindestens eine erste Wand (4) mit einem Rand (4a) aufweist, der mit der unteren Wand (3) verbunden und in der geschlossenen Konfiguration der Umhüllung zur Anordnung über der unteren Wand (3) geeignet ist; wobei die erste Wand (4) zum Variieren ihrer Oberflächenausdehnung ausdehnbar ist, sodass unabhängig von der Menge abzulegenden Materials, das in diesem Raum (S) beinhaltet ist, dieselbe Ausrichtung zwischen der ersten Wand (4) und der unteren Wand (3) gestattet wird, wobei die erste Wand (4) einen ersten Abschnitt (8) und einen zweiten Abschnitt (9) umfasst, die miteinander teleskopartig verbunden sind, wobei der erste Abschnitt (8) und der zweite Abschnitt (9) aneinander angrenzen und zumindest teilweise gemäß einer Vielzahl von unterschiedlichen Betriebskonfigurationen einander überlappt werden können,

- wobei jede Betriebskonfiguration eine entsprechende Oberflächenausdehnung der ersten Wand (4) definiert, wobei der erste Abschnitt (8) den Rand (4a) aufweist, der mit der unteren Wand (3) verbunden ist, wobei der zweite Abschnitt (9) eine Hüllenform zum verschiebbaren Aufsetzen auf den ersten Abschnitt (8) an einem Ende des ersten Abschnitts (8) gegenüber dem Rand (4a) aufweist, wobei der Ordner **dadurch gekennzeichnet ist, dass** er Fixiermittel (10) umfasst, die zwischen dem ersten und dem zweiten Abschnitt (8, 9) zum andauernden Fixieren des zweiten Abschnitts (9) relativ zum ersten Abschnitt (8) bei einer Vielzahl von festgelegten Konfigurationen aktiv sind, wobei die Fixiermittel (10) lösbar sind, um eine Änderung der Positionierung des zweiten Abschnitts (9) relativ zum ersten Abschnitt (8) zu gestatten.
2. Ordner nach Anspruch 1, **dadurch gekennzeichnet, dass** der zweite Abschnitt (9) eine Oberflächenausdehnung aufweist, die im Wesentlichen der Oberflächenausdehnung des ersten Abschnitts (8) entspricht.
  3. Ordner nach Anspruch 1, **dadurch gekennzeichnet, dass** der zweite Abschnitt (9) eine Oberflächenausdehnung aufweist, die im Wesentlichen der Oberflächenausdehnung des unteren Abschnitts (3) entspricht.
  4. Ordner nach einem oder mehreren der Ansprüche 1 bis 3, **dadurch gekennzeichnet, dass** die erste Wand (4) zum Einnehmen einer minimalen Ausdehnungskonfiguration ausdehnbar ist, wobei der erste Abschnitt (8) vollständig in den zweiten Abschnitt (9) zum Definieren einer Gesamtausdehnung eingefügt ist, die im Wesentlichen der unteren Wand (3) entspricht, und einer maximalen Ausdehnungskonfiguration, wobei der erste Abschnitt (8) zumindest teilweise aus dem zweiten Abschnitt (9) zum Definieren einer Gesamtausdehnung herausgezogen ist, die größer als die untere Wand (3) ist.
  5. Ordner nach Anspruch 1, **dadurch gekennzeichnet, dass** die Fixiermittel (10) mindestens ein erstes Element (11) umfassen, das am zweiten Abschnitt (9) fixiert ist, sowie eine Vielzahl von zweiten Elementen (12), die am ersten Abschnitt (8) fixiert sind, und die einschnappend mit dem ersten Element (11) verbunden werden können, wobei die zweiten Elemente (12) entlang einer Richtung des Verschiebens des zweiten Abschnitts (9) auf dem ersten Abschnitt (8) ausgerichtet angeordnet sind.
  6. Ordner nach Anspruch 1, **dadurch gekennzeichnet, dass** die Fixiermittel (10) eine Verbindung mit Velcro® umfassen, wobei die Verbindung mindestens einen Streifen (13) umfasst, der am ersten Abschnitt (8) fixiert ist und entlang einer Richtung des Verschiebens des zweiten Abschnitts (9) auf dem ersten Abschnitt (8) ausgerichtet ist, sowie mindestens ein Greifelement (14), das am zweiten Abschnitt (9) fixiert ist und andauernd mit dem Streifen (13) in Eingriff gebracht werden kann.
  7. Ordner nach Anspruch 1, **dadurch gekennzeichnet, dass** er mindestens einen lösbaren Verschluss umfasst, der zwischen dem zweiten Abschnitt (9) der ersten Wand (4) und der unteren Wand (3) zum Erhalt eines andauernden und umkehrbaren Verschlusses des Ordners (1) aktiv ist.
  8. Ordner nach einem oder mehreren der vorangehenden Ansprüche, **dadurch gekennzeichnet, dass** die erste Wand (4) entsprechende Vorschwächungslinien (4b) aufweist, die parallel zum Rand (4a) sind und entsprechende Falllinien zum Anpassen der ersten Wand (4) an die äußere Form des abzulegenden Materials (M) definieren, das in dem Raum (S) enthalten ist.
  9. Ordner nach einem oder mehreren der vorangehenden Ansprüche, **dadurch gekennzeichnet, dass** er eine zweite Wand (5) umfasst, die relativ zum Rand (4a) der ersten Wand (4) gegenüberliegend mit der unteren Wand (3) verbunden ist und mit der ersten Wand (4) zusammenwirkt, um einen seitlichen Verschluss des Ordners (1) zu erhalten.
  10. Ordner nach Anspruch 9, **dadurch gekennzeichnet, dass** er eine dritte und eine vierte Wand (6, 7) umfasst, die mit der unteren Wand (3) verbunden und relativ zueinander in gegenüberliegender Position angeordnet sind, wobei die dritte und vierte Wand (6, 7) quer zur ersten und zweiten Wand (4, 5) angeordnet sind, um einen seitlichen Verschluss des Ordners (1) zu vervollständigen.
  11. Ordner nach Anspruch 9 oder 10, **dadurch gekennzeichnet, dass** die zweite Wand (5) und/oder die dritte und vierte Wand (6, 7) entsprechende Vorschwächungslinien (5b, 6b, 7b) aufweisen, die entsprechende Falllinien zum Anpassen an die äußere Abmessung des abzulegenden Materials (M) definieren, das in dem Raum (S) enthalten ist.
  12. Ordner nach einem oder mehreren der vorangehenden Ansprüche, **dadurch gekennzeichnet, dass** er aus Karton gefertigt ist.

#### Revendications

1. Classeur comprenant une enveloppe externe adaptée pour prendre une configuration ouverte et une configuration fermée et définissant un espace (S) à

- l'intérieur pour recevoir le matériel (M) à classer, ladite enveloppe présentant une paroi de fond (3) et au moins une première paroi (4) ayant un bord (4a) relié à la paroi de fond (3) et adaptée pour disposer au-dessus du paroi de fond (3) dans ladite configuration fermée de l'enveloppe ; ladite première paroi (4) étant extensible pour modifier un allongement de la surface de cette dernière pour permettre un même alignement entre ladite première paroi (4) et ladite paroi de fond (3) indépendamment de la quantité de matériel à classer inclus à l'intérieur dudit espace (S), ladite première paroi (4) comprenant une première portion (8) et une deuxième portion (9) reliées l'une à l'autre de façon télescopique, lesdites première portion (8) et deuxième portion (9) étant contiguës l'une à l'autre et pouvant se chevaucher au moins partiellement selon une pluralité de configurations opérationnelles différentes, chaque configuration opérationnelle définissant un allongement respectif de la surface de la première paroi (4), ladite première portion (8) présentant ledit bord (4a) relié à la paroi de fond (3), ladite deuxième portion (9) présentant une forme d'enveloppe pour être montée de façon coulissante sur ladite première portion (8) à une extrémité de ladite première portion (8) opposée audit bord (4a), le classeur étant **caractérisé en ce qu'il** comprend un moyen de fixation (10) actif entre la première et la deuxième portion (8, 9) pour fixer constamment la deuxième portion (9) par rapport à la première portion (8) en une pluralité de configurations prédéterminées, ledit moyen de fixation (10) étant amovible pour permettre une modification du positionnement de la deuxième portion (9) par rapport à la première portion (8).
2. Classeur selon la revendication 1, **caractérisé en ce que** ladite deuxième portion (9) présente un allongement de la surface essentiellement égal à l'allongement de la surface de la première portion (8).
  3. Classeur selon la revendication 1, **caractérisé en ce que** ladite deuxième portion (9) présente un allongement de la surface essentiellement égal à l'allongement de la surface de la portion de fond (3).
  4. Classeur selon une ou plusieurs des revendications 1 à 3, **caractérisé en ce que** ladite première paroi (4) est extensible pour prendre une configuration d'allongement minimum, où ladite première portion (8) est entièrement insérée dans ladite deuxième portion (9) pour définir un allongement global essentiellement égal à la paroi de fond (3), et une configuration d'allongement maximum, où la première portion (8) est au moins partiellement extraite de la deuxième portion (9) pour définir un allongement global de la surface supérieur à la paroi de fond (3).
  5. Classeur selon la revendication 1, **caractérisé en ce que** ledit moyen de fixation (10) comprend au moins un premier élément (11) fixé à ladite deuxième portion (9), et une pluralité de deuxièmes éléments (12) fixés à ladite première portion (8) et qui peut être relié par encliquetage au premier élément (11); lesdits deuxièmes éléments (12) étant alignés le long d'une direction de coulissement de la deuxième portion (9) sur la première portion (8).
  6. Classeur selon la revendication 1, **caractérisé en ce que** ledit moyen de fixation (10) comprend un raccord avec du Velcro®, ledit raccord comprenant au moins une bande (13) fixée à ladite première portion (8) et orientée en alignement le long d'une direction de coulissement de la deuxième portion (9) de la première portion (8), et au moins un élément de préhension (14) fixé à ladite deuxième portion (9) et pouvant s'engager constamment avec ladite bande (13).
  7. Classeur selon la revendication 1, **caractérisé en ce qu'il** comprend au moins une fermeture amovible, active entre ladite deuxième portion (9) de la première paroi (4) et ladite paroi de fond (3) pour obtenir une fermeture constante et réversible du classeur (1).
  8. Classeur selon une ou plusieurs des revendications précédentes, **caractérisé en ce que** ladite première paroi (4) présente des lignes pré-fragilisées (4b) parallèles audit bord (4a) et définissant des lignes de pliage respectives pour adapter la première paroi (4) à la forme extérieure du matériel (M) à classer contenu dans ledit espace (S).
  9. Classeur selon une ou plusieurs des revendications précédentes, **caractérisé en ce qu'il** comprend une deuxième paroi (5) reliée à la paroi de fond (3) opposée audit bord (4a) de la première paroi (4) et coopérant avec ladite première paroi (4) pour obtenir une fermeture latérale du classeur (1).
  10. Classeur selon la revendication 9, **caractérisé en ce qu'il** comprend une troisième et une quatrième paroi (6, 7), reliées à la paroi de fond (3) et disposées dans une position opposée l'une à l'autre, lesdites troisième et quatrième parois (6, 7) étant disposées transversalement par rapport à la première et à la deuxième parois (4, 5) pour compléter une fermeture latérale du classeur (1).
  11. Classeur selon la revendication 9 ou 10, **caractérisé en ce que** ladite deuxième paroi (5) et/ou lesdites troisième et quatrième parois (6, 7) présentent des lignes pré-fragilisées respectives (5b, 6b, 7b) définissant des lignes de pliage respectives pour adapter la taille externe du matériel (M) à classer contenu dans ledit espace (S).

12. Classeur selon une ou plusieurs des revendications précédentes, **caractérisé en ce qu'il** est réalisé avec du carton.

5

10

15

20

25

30

35

40

45

50

55

8

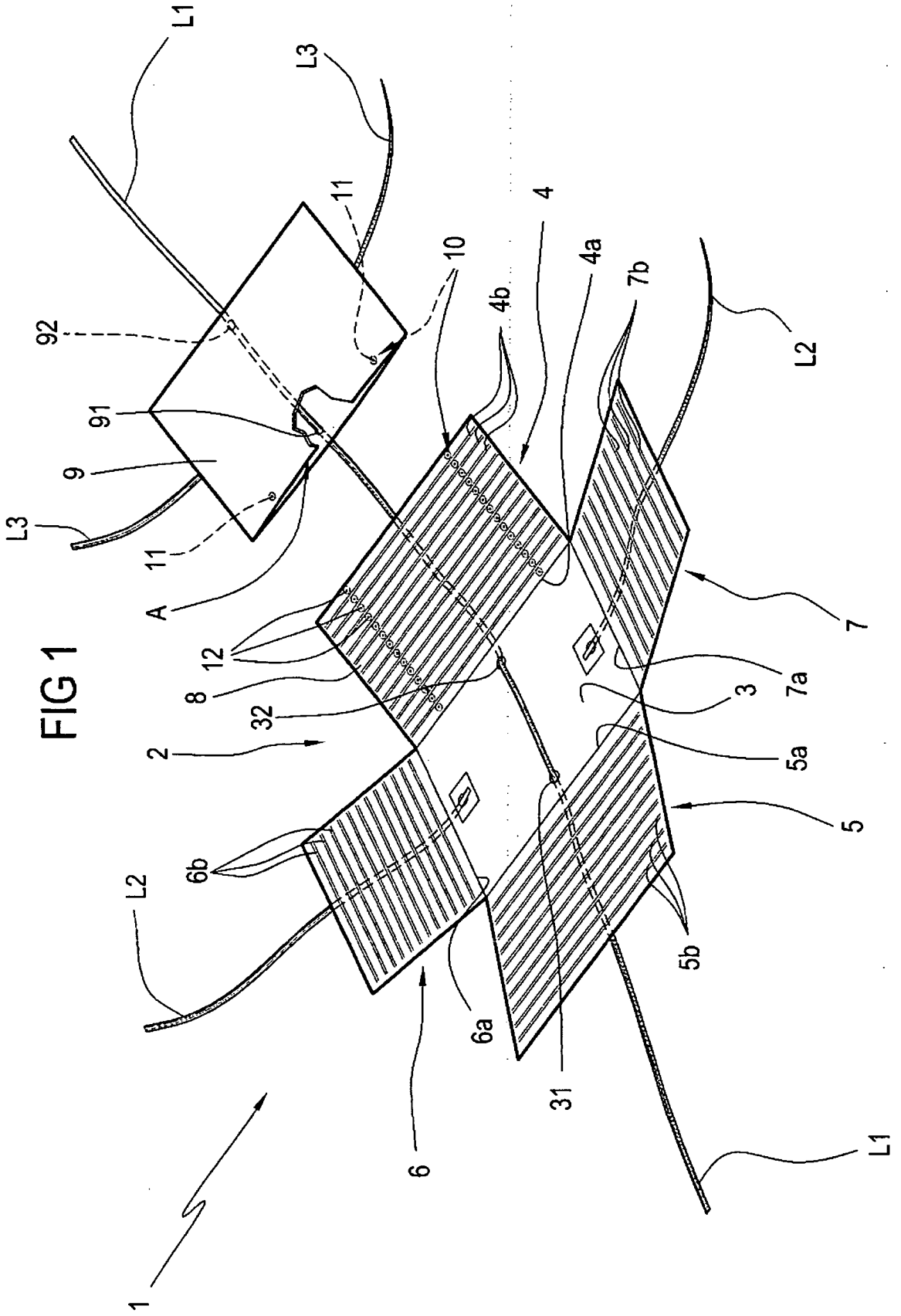





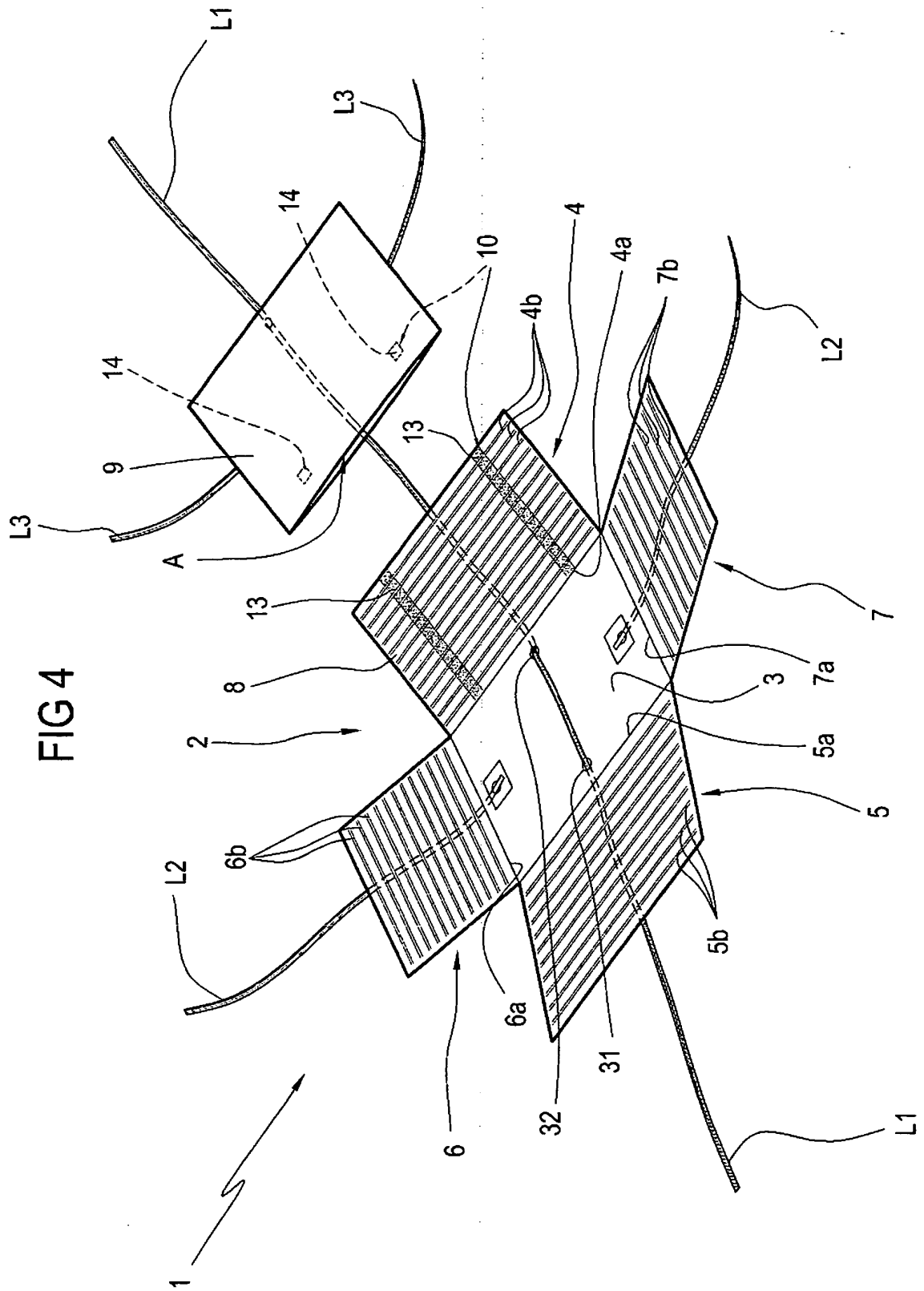

FIG 5

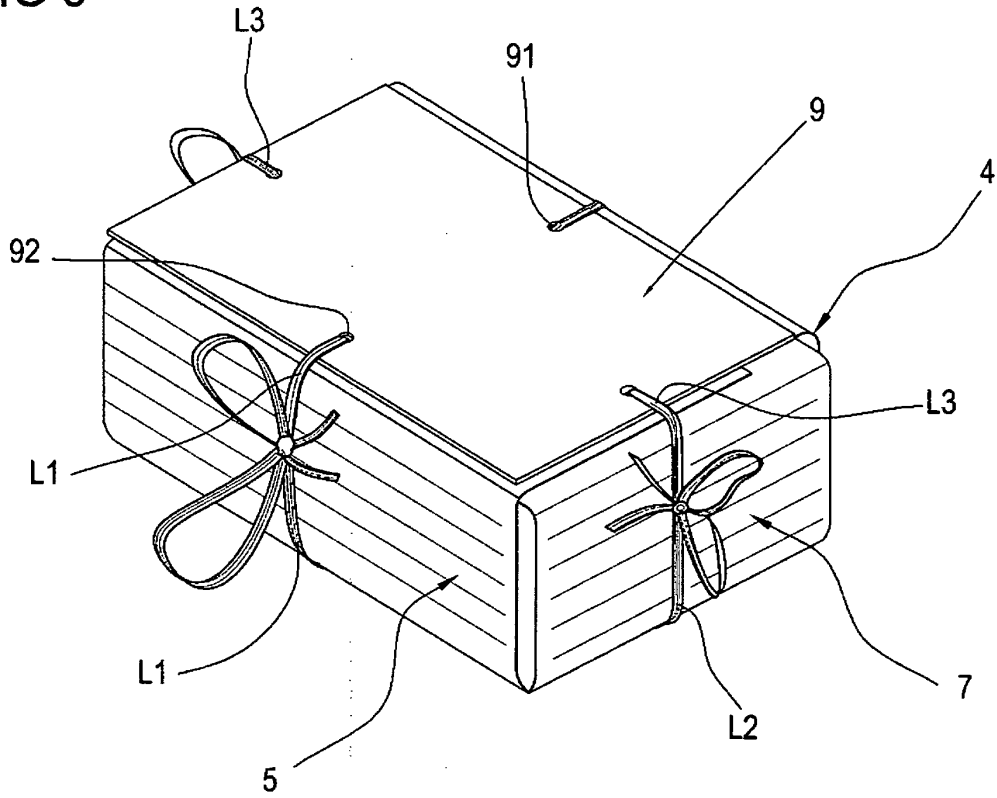
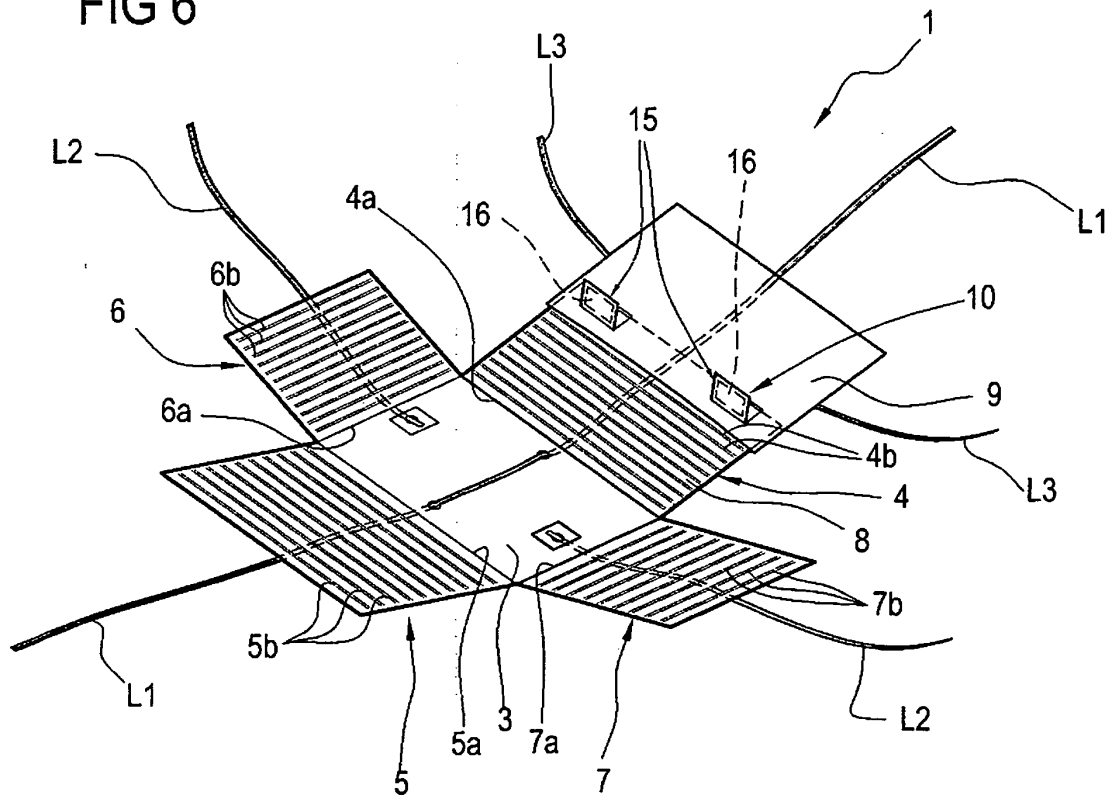

FIG 6



**REFERENCES CITED IN THE DESCRIPTION**

*This list of references cited by the applicant is for the reader's convenience only. It does not form part of the European patent document. Even though great care has been taken in compiling the references, errors or omissions cannot be excluded and the EPO disclaims all liability in this regard.*

**Patent documents cited in the description**

- FR 2082000 [0002]
- FR 2524391 [0007]
- GB 2406076 A [0009]
- DE 19620506 [0010]
- DE 19735383 [0011]