

May 31, 1938.

C. GOERGEN  
PNEUMATIC TOY

2,118,971

Filed July 14, 1937

4 Sheets-Sheet 1

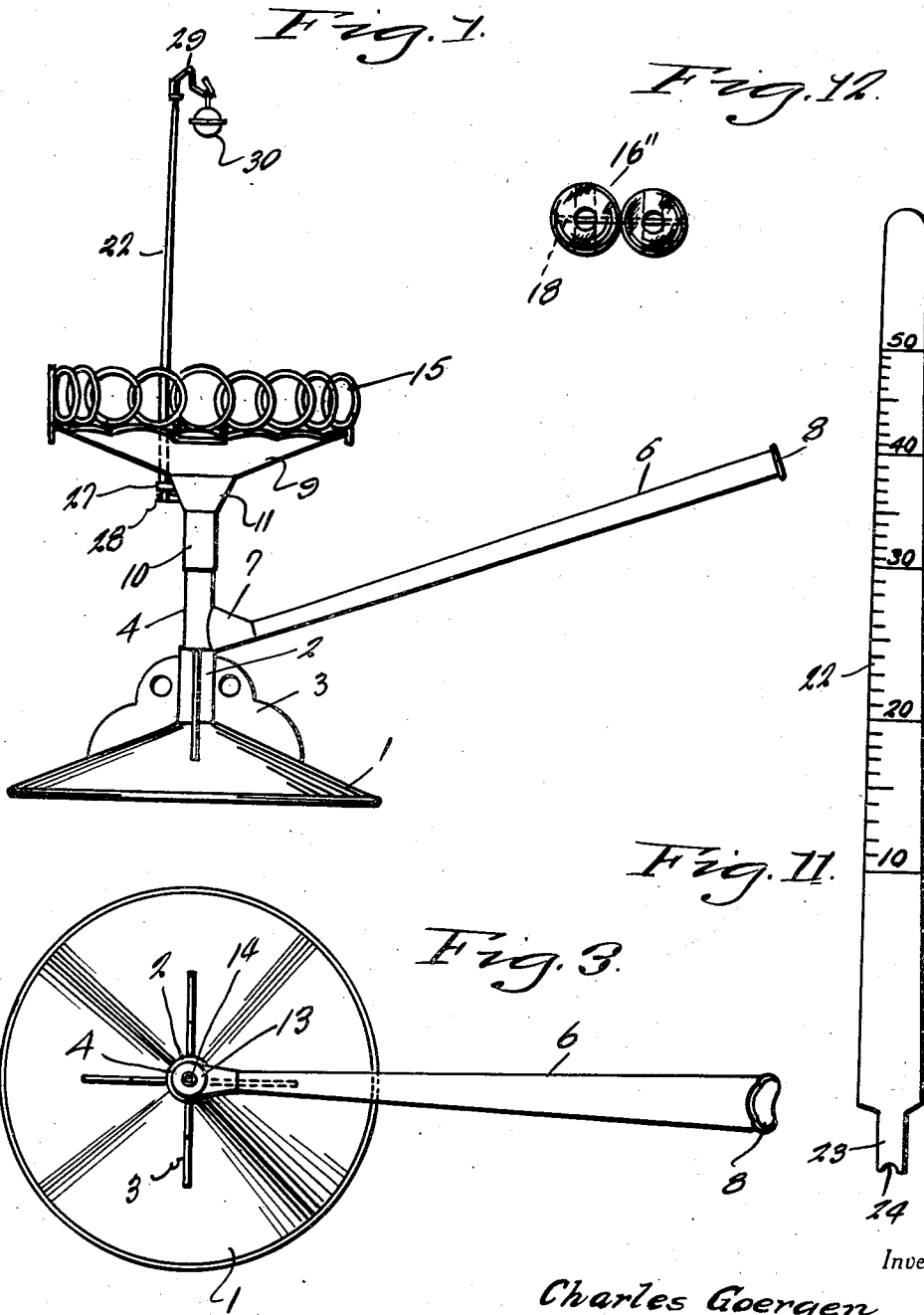

Inventor

Charles Goergen

By *Alance W. Brion*  
*Hyman Berman*

Attorneys

May 31, 1938.

C. GOERGEN

2,118,971

PNEUMATIC TOY

Filed July 14, 1937

4 Sheets-Sheet 2

Fig. 2

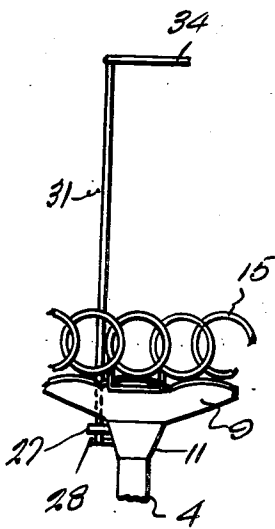

Fig. 9

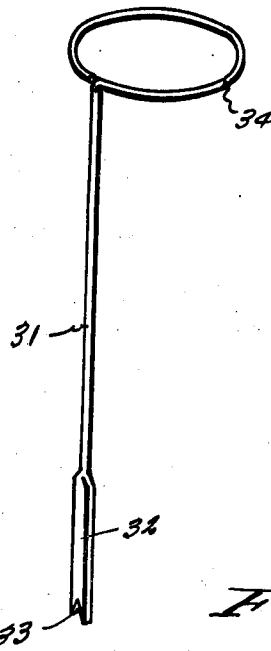

Fig. 7

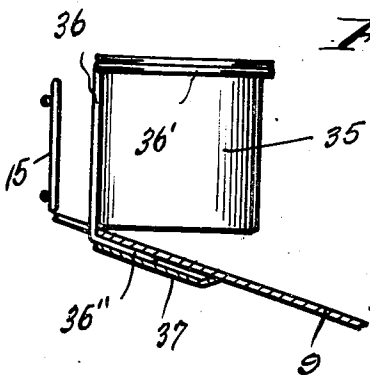

Fig. 6

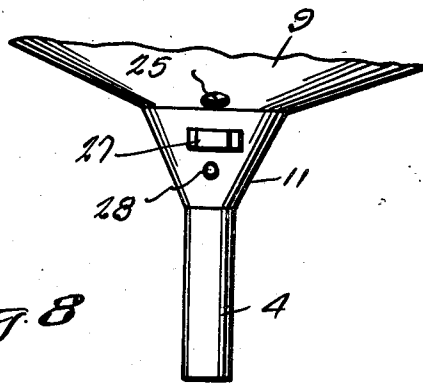
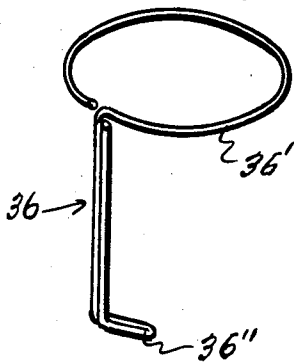

Fig. 8



Inventor

Charles Goergen

By *Clarence W. Brien*  
*Hyman Berman*

Attorneys

May 31, 1938.

C. GOERGEN

2,118,971

PNEUMATIC TOY

Filed July 14, 1937

4 Sheets-Sheet 3

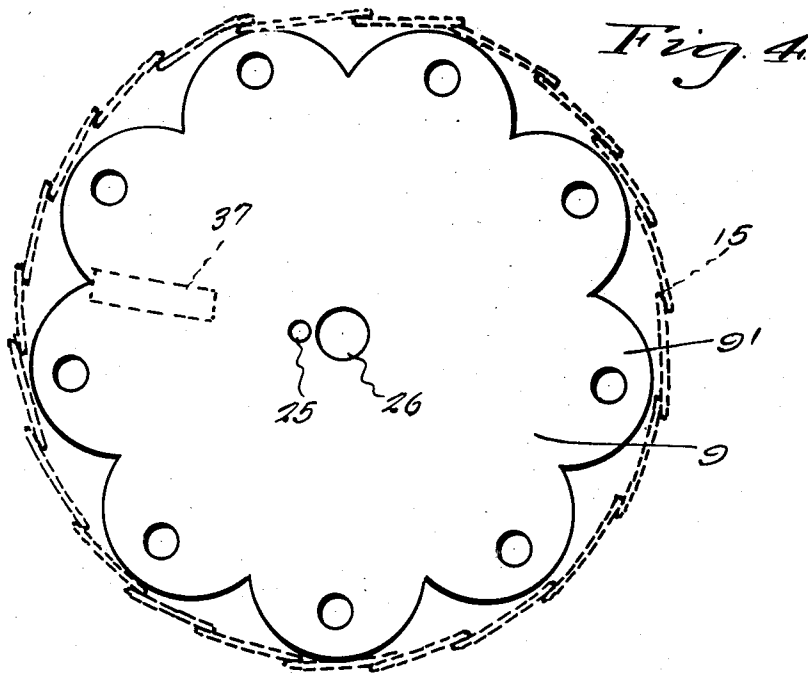

Fig. 13

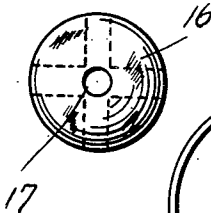

Fig. 14

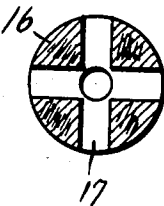

Fig. 15

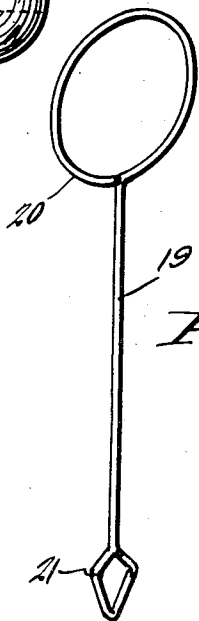
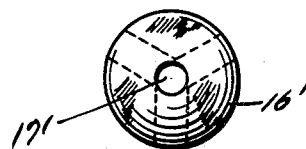
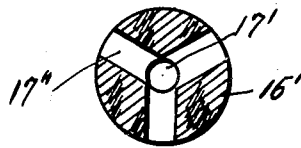

Fig. 10

Fig. 16



Inventor

Charles Goergen

By *Clarence A. Orion*  
*Hyman Berman*

Attorneys

May 31, 1938.

C. GOERGEN

2,118,971

PNEUMATIC TOY

Filed July 14, 1937

4 Sheets-Sheet 4

Fig. 5.

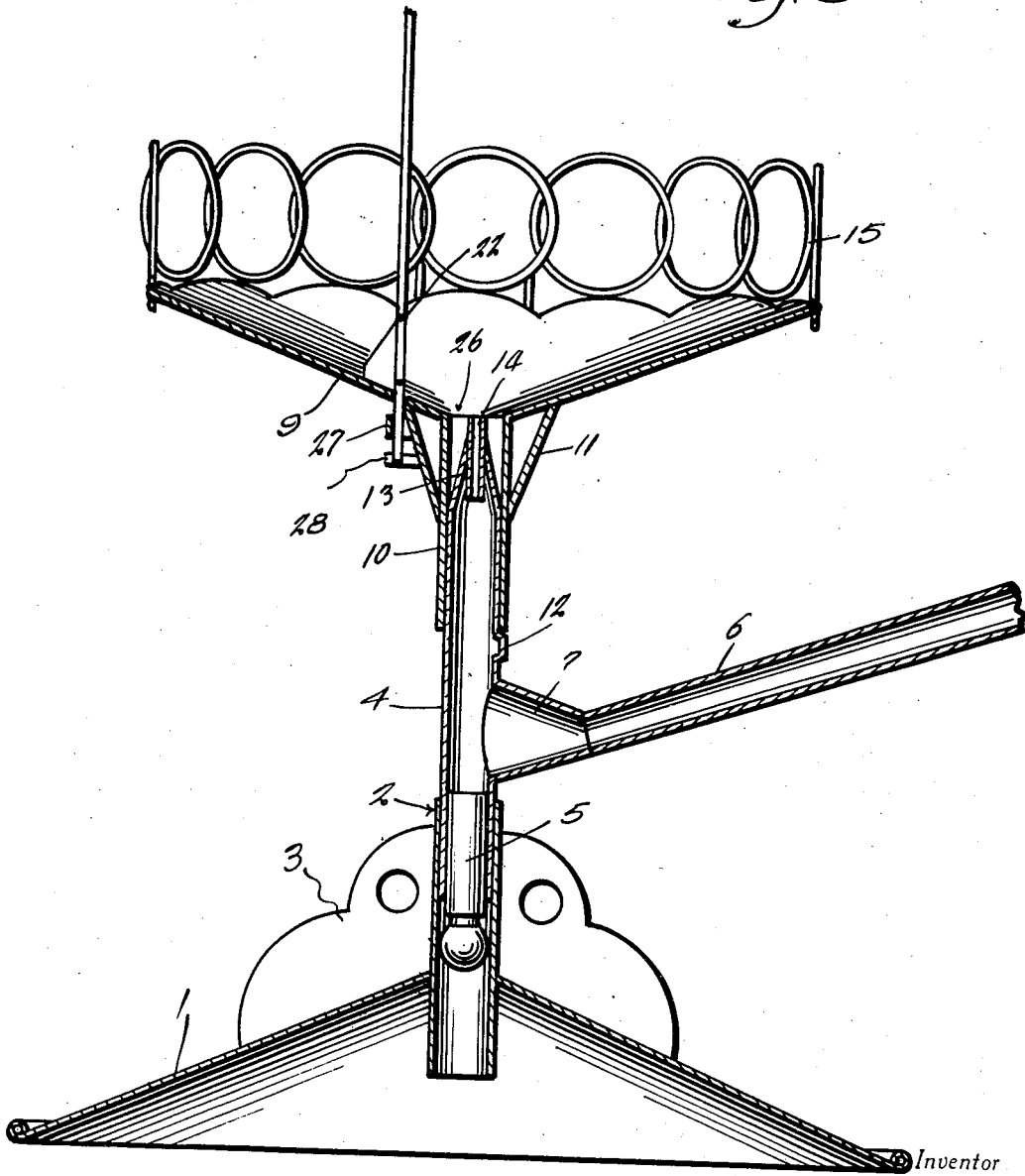

Inventor

Charles Goergen

By Clarence A. O'Brien,  
Hyman Berman

Attorneys

# UNITED STATES PATENT OFFICE

2,118,971

## PNEUMATIC TOY

Charles Goergen, St. Louis, Mo.

Application July 14, 1937, Serial No. 153,654

### 1 Claim. (Cl. 46—44)

This invention relates to a pneumatic toy, the general object of the invention being to provide means whereby through blowing into a tube a ball can be made to do various things relatively to certain parts of the invention, thus providing amusement and pleasure to the one using the invention and to spectators while at the same time promoting the health of the users by giving exercise to the lungs.

This invention also consists in certain other features of construction and in the combination and arrangement of several parts, to be hereinafter fully described, illustrated in the accompanying drawings and specifically pointed out in the appended claim.

In describing the invention in detail, reference will be had to the accompanying drawings wherein like characters denote like or corresponding parts throughout the several views, and in which:—

Figure 1 is an elevation of the device and this figure shows a standard supported from the bowl of the device and in turn supporting a bell.

Figure 2 is a fragmentary elevation showing a second standard supported by the device, said standard having a loop at its upper end.

Figure 3 is a top plan view of the base and the blow tube with the bowl removed.

Figure 4 is a top plan view of the bowl.

Figure 5 is a vertical sectional view through the device with parts in elevation.

Figure 6 is a fragmentary elevation of the bowl and its depending parts and showing the supporting means for the standards.

Figure 7 is a detail vertical sectional view through a portion of the bowl and showing the cup and the means for supporting the same from the bowl.

Figure 8 is a view of the supporting means for the cup.

Figure 9 is a view of the looped standard.

Figure 10 is a view of a rod having a loop at one end and a handle at its other.

Figure 11 is a view of the graduated standard, shown in Figure 1.

Figure 12 is a view of a pair of balls connected together.

Figure 13 is a view of a single ball used with the device.

Figure 14 is a sectional view through such ball.

Figure 15 is a view of a modified form of ball.

Figure 16 is a sectional view through Figure 15.

In the drawings, the numeral 1 indicates the conical base of the device which has a vertically

arranged tubular part 2 extending upwardly from its central portion, braces 3 connecting this tubular part with the base, as shown.

A tube 4 has its lower end removably fitting in the part 2 and the lower end of the tube 4 is closed by a plug 5 which can be removed, after the part 4 is removed from the part 2, so that any foreign matter in the part 4 can be removed therefrom.

A blow tube 6 has an enlarged end 7 connected with the intermediate part of the tube 4 and in communication therewith, the outer end of the tube 6 having a mouthpiece 8 thereon. This tube 6 slopes upwardly and outwardly as shown so that one can readily place his mouth against the part 8 to blow into the tube 6 while the base is setting on a table or other support.

The bowl 9 is of substantially inverted conical shape and has a tubular part 10 extending downwardly from its central part, this tubular part 10 being braced as at 11. The part 10 removably fits over the upper portion of the tube 4 and a projection 12 on the part 4 limits downward movement of the part 10. The upper end of the part 4 tapers upwardly to provide a cone 13 and a small tube 14 passes through a small upper end of the cone and is attached thereto by welding or the like, with a part of the tube 14 located in the conical part 13 and another part projecting above the conical part and approximately in the same plane as the top of the tubular portion 10, as shown in Figure 5. Thus the conical part 13 and the tube 14 form a trap for receiving any foreign matter dropping into the bowl and, of course, the small tube 14 forms an air jet for the escape of the air blown into the tube 4 from the tube 6.

The outer edge of the bowl 9 is scalloped as shown at 9' and overlapping rings 15 are connected to each other and to the edge of the bowl to form a vertical rim for the bowl.

Balls of light material, such as cork, are used with the device and one type of ball is shown at 16 in Figures 13 and 14. As will be seen from these figures the ball is formed with the diametrically extending holes 17 therein which intersect each other at the center of the ball. Figures 15 and 16 show another type of ball at 16', this ball being formed with a diametrically arranged opening 17' and the openings or holes 17'' which radiate from the opening 17'. Figure 12 shows a pair of balls 16'' fastened together by a pin 18 and these balls may be of the type shown in Figures 13 and 14 or that shown in Figures 15 and 16.

It will, of course, be understood that when a ball, of any of the types shown, is placed in the bowl it will gravitate to the central and lower point of the bowl and thus be positioned over the jet forming tube 14, so that when one blows into the tube 6 the air passing through the tube 14 will form a small stream which will act to elevate the ball and hold it in elevated position. Of course, by blowing with more or less force into the device the ball can be raised and lowered as desired.

I also provide several attachments for the device for adding to the interest of the users and to develop skill in causing the ball to do certain things, or act in certain ways relative to the attachment.

Figure 10 shows a rod 19 having a loop 20 formed at one end and a handle 21 at the other end. This rod can be held in one hand and placed over the bowl and the ball made to pass through it or the loop can be turned and pass at right angles to the air stream and pass back and forth or up and down over the ball. By keeping up the blowing action as long as possible, the lungs will be developed.

A graduated standard, shown in Figure 11, at 22 is also provided for use with the device, the lower end of the standard being reduced as at 23 and having a recess 24 in its lower end. The reduced end is adapted to pass through a small hole 25 in the bowl adjacent the central hole 26 which receives the upper end of the tube 10 and as it passes through the hole 25 the part 23 passes through a loop 27 on the brace 11 with the recess 24 engaging a pin 28 on said part 11. Thus by watching the scale on the standard 22 the height to which the ball has been propelled by the air blast can be ascertained.

A bracket 29 is adapted to be placed over the upper end of the standard 22 to support a small bell 30, as shown in Figure 1. Thus by causing the air blast to raise the ball against the bell said bell will be sounded.

Figure 9 shows another form of standard 31 which has a base 32 adapted to be passed through the hole 25 and the bracket 27 with the recess 33 engaging the pin 28. This standard has a right angularly extending loop 34 at its upper end to which the ball may be made to pass, when this standard is in use. Figure 2 shows this standard in use.

I also provide a cup 35 which is to be supported at one side of the bowl and the balls are to be manipulated in such a manner as to be made to drop into the cup. The cup is removably sup-

ported by means of the bracket 36 shown in Figures 7 and 8. This bracket has a loop 36' at its upper end and its lower end is bent as at 36'' to enter a socket 37 formed on the underside of an edge portion of the bowl as shown in Figure 7. As this cup is placed to one side of the air stream or jet passing from the small tube 14, it will be seen, that considerable skill and practice is required to place the balls in the cup. However, by blowing into the tube 6 with a short puff the ball can be made to jump upwardly and into the cup.

As before stated this device will develop the lungs, thus increasing the health of the user and after practicing with the device, the balls can be made to do quite a number of different things. For instance, the ball can be held at certain points on the scale of the standard 22 and the players can have contests to see which can hold the ball the longest at the highest point on the scale. Also the players can see who can place a certain number of balls in the cup the quickest. Of course the rings 15 should overlap sufficiently or be of such a size as to prevent the balls from passing therethrough and by providing the holes in the balls said balls are made much lighter and the ends of said holes form air grips so that the air will have more effect in lifting the ball than it would if the ball was made to move over its entire surface.

It is thought from the foregoing description that the advantages and novel features of the invention will be readily apparent.

It is to be understood that changes may be made in the construction and in the combination and arrangement of the several parts, provided that such changes fall within the scope of the appended claim.

Having described the invention what is claimed as new is:—

A device of the class described comprising a base, a vertically arranged tubular part attached to the base, a tube having its lower end removably fitting in the tubular part, a plug for closing the lower end of the tube, a blow tube having one end connected with an intermediate part of the tube, a mouthpiece at the other end of the blow tube, a bowl having a tubular portion depending from its center and removably fitting over the upper end of the first-mentioned tube, a jet forming tube carried by the upper end of the first-mentioned tube, said upper end being of conical form and forming a trap with the upper portion of the tubular part depending from the bowl.

CHARLES GOERGEN.