



- (51) International Patent Classification:
G06Q 20/00 (2012.01)
- (21) International Application Number:
PCT/US2018/030741
- (22) International Filing Date:
02 May 2018 (02.05.2018)
- (25) Filing Language: English
- (26) Publication Language: English
- (30) Priority Data:
62/500,314 02 May 2017 (02.05.2017) US
15/969,715 02 May 2018 (02.05.2018) US
- (71) Applicant: BATON SYSTEMS, INC. [US/US]; 1003 Olive Ave., Fremont, California 94539 (US).
- (72) Inventors: JAYARAM, Arjun; 1003 Olive Ave., Fremont, California 94539 (US). ABIDI, Mohammad Taha; 308 Dawes Ct., San Ramon, California 94582 (US). MANDELL, Daniel Craig; 100 Suffield Ave., San Anselmo, California 94960 (US).
- (74) Agent: SPONSELLER, Steven; Strategic IP Solutions, LLC, 624 W. Hastings Road, Suite 3, Spokane, Washington 99218 (US).

- (81) Designated States (unless otherwise indicated, for every kind of national protection available): AE, AG, AL, AM, AO, AT, AU, AZ, BA, BB, BG, BH, BN, BR, BW, BY, BZ, CA, CH, CL, CN, CO, CR, CU, CZ, DE, DJ, DK, DM, DO, DZ, EC, EE, EG, ES, FI, GB, GD, GE, GH, GM, GT, HN, HR, HU, ID, IL, IN, IR, IS, JO, JP, KE, KG, KH, KN, KP, KR, KW, KZ, LA, LC, LK, LR, LS, LU, LY, MA, MD, ME, MG, MK, MN, MW, MX, MY, MZ, NA, NG, NI, NO, NZ, OM, PA, PE, PG, PH, PL, PT, QA, RO, RS, RU, RW, SA, SC, SD, SE, SG, SK, SL, SM, ST, SV, SY, TH, TJ, TM, TN, TR, TT, TZ, UA, UG, US, UZ, VC, VN, ZA, ZM, ZW.
- (84) Designated States (unless otherwise indicated, for every kind of regional protection available): ARIPO (BW, GH, GM, KE, LR, LS, MW, MZ, NA, RW, SD, SL, ST, SZ, TZ, UG, ZM, ZW), Eurasian (AM, AZ, BY, KG, KZ, RU, TJ, TM), European (AL, AT, BE, BG, CH, CY, CZ, DE, DK, EE, ES, FI, FR, GB, GR, HR, HU, IE, IS, IT, LT, LU, LV, MC, MK, MT, NL, NO, PL, PT, RO, RS, SE, SI, SK, SM, TR), OAPI (BF, BJ, CF, CG, CI, CM, GA, GN, GQ, GW, KM, ML, MR, NE, SN, TD, TG).

(54) Title: LEDGER MANAGEMENT SYSTEMS AND METHODS

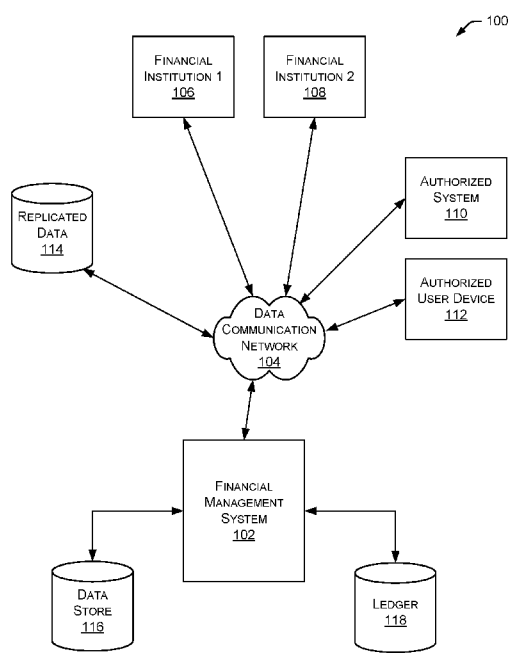

FIG. 1

(57) Abstract: Example ledger management systems and methods are described. In one implementation, a financial management system receives a transfer request that identifies a source account and a destination account. The financial management system confirms that the source account is valid and confirms that the source account has a sufficient balance for the transfer request. Further, the financial management system issues instructions to debit the source account and credit a settlement account. If the source account is valid and has sufficient balance for the transfer request, instructions are sent to move funds from the settlement account to the destination account.

WO 2018/204548 A1

Declarations under Rule 4.17:

- *as to applicant's entitlement to apply for and be granted a patent (Rule 4.17(ii))*
- *as to the applicant's entitlement to claim the priority of the earlier application (Rule 4.17(iii))*

Published:

- *with international search report (Art. 21(3))*

LEDGER MANAGEMENT SYSTEMS AND METHODS

RELATED APPLICATIONS

[0001] This application claims the priority benefit of U.S. Non Provisional
5 Application Serial No. 15/969,715, entitled “Ledger Management Systems and Methods,”
filed on May 2, 2018, which claims priority benefit of U.S. Provisional Application Serial
No. 62/500,314, entitled “Use of Distributed Ledger, Real Time Balance Checks,
Earmarking, Notifications and On-Demand Settlements across Heterogeneous Ledgers,”
filed on May 2, 2017, the disclosures of which are hereby incorporated by reference herein
10 in their entireties.

TECHNICAL FIELD

[0002] The present disclosure relates to financial systems and, more particularly,
to systems and methods that manage one or more ledgers.
15

BACKGROUND

[0003] Various financial systems are used to transfer assets between different
organizations, such as financial institutions. For example, in existing systems, each
financial institution maintains a ledger to keep track of accounts at the financial institution
20 and transactions associated with those accounts. Financial institutions generally cannot
access the ledger of another financial institution. Thus, a particular financial institution
can only see part of a financial transaction (i.e., the part of the transaction associated with
that financial institution’s accounts). When executing critical asset transfers, it is
important that all parties to the transfer can see the details of the transfer. Further, it is

important to confirm that funds are available in a source account before releasing assets, goods, or services purchased using funds in the source account.

BRIEF DESCRIPTION OF THE DRAWINGS

5 **[0004]** Non-limiting and non-exhaustive embodiments of the present disclosure are described with reference to the following figures, wherein like reference numerals refer to like parts throughout the various figures unless otherwise specified.

[0005] FIG. 1 is a block diagram illustrating an environment within which an example embodiment may be implemented.

10 **[0006]** FIG. 2 is a block diagram illustrating an embodiment of a financial management system configured to communicate with multiple other systems.

[0007] FIG. 3 illustrates an embodiment of an example asset transfer between two financial institutions.

[0008] FIG. 4 illustrates an embodiment of a method for transferring assets
15 between two financial institutions.

[0009] FIG. 5 illustrates an embodiment of a method for authenticating a client and validating a transaction.

[0010] FIG. 6 is a block diagram illustrating an embodiment of a financial management system interacting with an API server and an audit server.

20 **[0011]** FIG. 7 illustrates an embodiment of an example financial environment.

[0012] FIG. 8 is a block diagram illustrating an environment within which an example embodiment may be implemented.

[0013] FIG. 9 illustrates an embodiment of a method for implementing a transfer request.

[0014] FIG. 10 illustrates an embodiment of an example configuration of multiple nodes and a distributed transaction store.

[0015] FIG. 11 illustrates another embodiment of an example configuration of multiple nodes and a distributed transaction store.

5 [0016] FIG. 12 illustrates an example state diagram showing various states that a transaction may pass through.

[0017] FIG. 13 is a block diagram illustrating an embodiment of a financial management system interacting with a cryptographic service and multiple client nodes.

[0018] FIG. 14 is a block diagram illustrating an example computing device.

10

DETAILED DESCRIPTION

[0019] It will be readily understood that the components of the present systems and methods, as generally described and illustrated in the figures herein, could be arranged and designed in a wide variety of different configurations. The following detailed
15 description of the embodiments of the ledger management systems and methods is not intended to limit the scope of the invention, as claimed, but is merely representative of certain examples of presently contemplated embodiments in accordance with the invention.

[0020] Existing financial institutions typically maintain account information and
20 asset transfer details in a ledger at the financial institution. The ledgers at different financial institutions do not communicate with one another and often use different data storage formats or protocols. Thus, each financial institution can only access its own ledger and cannot see data in another financial institution's ledger, even if the two financial institutions implemented a common asset transfer.

[0021] The systems and methods described herein enable institutions to move assets on demand by enabling authorized users to execute complex workflows. Additionally, the described systems and methods allow one or more 3rd parties to view and confirm payment activities between participants. Further, the systems and methods support the synchronization of data, such as transaction data, across multiple ledgers. In some embodiments, the multiple ledgers are heterogeneous ledgers. In other situations, the multiple ledgers are non-heterogeneous ledgers. The systems and methods described herein are capable of on-demand settlements across multiple ledgers. Additionally, the systems and methods discussed herein are operable with DLT (Distributed Ledger Technology) systems and non-DLT systems. In some examples discussed herein, the systems and methods are discussed with respect to one or more financial institutions. However, the described systems and methods are applicable to any type of system associated with any entity. The described systems and methods are not limited to use with financial institutions.

[0022] As discussed herein, distributed ledger technology (DLT) is a database or other data storage mechanism that is spread across multiple systems or sites, such as different institutions and/or different geographic areas.

[0023] As used herein, a workflow describes, for example, the sequence of activities associated with a particular transaction, such as an asset transfer. In particular, the systems and methods provide a clearing and settlement gateway between, for example, multiple financial institutions. When a workflow is executed, the system generates and issues clearing and settlement messages (or instructions) to facilitate the movement of assets. A shared permissioned ledger (discussed herein) keeps track of the asset movement and provides visibility to the principals and observers in substantially real time. The integrity of these systems and methods is important because the systems are dealing

with core payments that are a critical part of banking operations. Additionally, many asset movements are final and irreversible. Therefore, the authenticity of the request and the accuracy of the instructions are crucial. Further, reconciliation of transactions between multiple parties are important to the management of financial data.

5 **[0024]** As discussed herein, payments between parties can be performed using multiple asset types, including currencies, treasuries, securities (e.g., notes, bonds, bills, and equities), and the like. Payments can be made for different reasons, such as margin movements, collateral pledging, swaps, delivery, fees, liquidation proceeds, and the like. As discussed herein, each payment may be associated with one or more metadata.

10 **[0025]** As used herein, DCC refers to a direct clearing client or an individual or institution that owes an obligation. A payee refers to an individual or institution that is owed an obligation. A CCG (or Guarantor) refers to a client clearing guarantor or an institution that guarantees the payment of an obligation. A CCP refers to a central counterparty clearinghouse and a Client is a customer of the FCM (Futures Clearing
15 Merchant)/CCG guarantor. Collateral settlements refer to non-cash based assets that are cleared and settled between CCP, FCM/CCG guarantor, and DCC. CSW refers to collateral substitution workflow, which is a workflow used for the pledging and recall (including substitution) of collateral for cash. A clearing group refers to a logical grouping of stakeholders who are members of that clearing group that are involved in the clearing
20 and settlement of one or more asset types. A workflow, when executed, facilitates a sequence of clearing and settlement instructions between members of a clearing group as specified by the workflow parameters.

[0026] When some financial transactions change state (e.g., initiated – pending – approved – cleared – settled, etc.) it may trigger one or more notifications to the principals
25 involved in the transaction. The systems and methods described herein provide multiple

ways to receive and respond to these notifications. In some embodiments, these notifications can be viewed and acknowledged using a dashboard associated with the described systems and methods or using one or more APIs.

[0027] As used herein, principals refer to the parties that are directly involved in a payment or transaction origination or termination. An observer refers to a party that is not a principal, but may be a stakeholder in a transaction. In some embodiments, an observer can subscribe for a subset of notifications generated by the systems and methods discussed herein. In some situations, one or more principals may need to agree that the observer can receive the subset of notifications. APIs refer to an application program interface that allow other systems and devices to integrate with the systems and methods described herein.

[0028] FIG. 1 is a block diagram illustrating an environment 100 within which an example embodiment may be implemented. A financial management system 102 is coupled to a data communication network 104 and communicates with one or more other systems, such as financial institutions 106, 108, an authorized system 110, an authorized user device 112, and a replicated data store 114. As discussed in greater detail herein, financial management system 102 performs a variety of operations, such as facilitating the transfer of assets between multiple financial institutions or other entities, systems, or devices. Although many asset transfers include the use of a central bank to clear and settle the funds, the central bank is not shown in FIG. 1. A central bank provides financial services for a country's government and commercial banking system. In the United States, the central bank is the Federal Reserve Bank. In some implementations, financial management system 102 provides an on-demand gateway integrated into the heterogeneous core ledgers of financial institutions (e.g., banks) to view funds and clear

and settle all asset classes. Additionally, financial management system 102 may efficiently settle funds using existing services such as FedWire.

[0029] In some embodiments, data communication network 104 includes any type of network, such as a local area network, a wide area network, the Internet, a cellular communication network, or any combination of two or more communication networks. The described systems and methods can use any communication protocol supported by a financial institution's ledger and other systems. For example, the communication protocol may include SWIFT MT (Society for Worldwide Interbank Financial Telecommunication Message Type) messages (such as MT 2XX, 5XX, 9XX), ISO 20022 (a standard for electronic data interchange between financial institutions), and proprietary application interfaces exposed by particular financial institutions. Financial institutions 106, 108 include banks, exchanges, hedge funds, and any other type of financial entity or system. In some embodiments, financial management system 102 interacts with financial institutions 106, 108 using existing APIs and other protocols already being used by financial institutions 106, 108, thereby allowing financial management system 102 to interact with existing financial institutions without significant modification to the financial institution's systems. Authorized system 110 and authorized user device 112 include any type of system, device, or component that is authorized to communicate with financial management system 102. Replicated data store 114 stores any type of data accessible by any number of systems and devices, such as the systems and devices described herein. In some embodiments, replicated data store 114 stores immutable and auditable forms of transaction data between financial institutions. The immutable data cannot be deleted or modified. In particular implementations, replicated data store 114 is an append only data store which keeps track of all intermediate states of the transactions. Additional metadata may be stored along with the transaction data for referencing information available in

external systems. In specific embodiments, replicated data store 114 may be contained within a financial institution or other system.

[0030] As shown in FIG. 1, financial management system 102 is also coupled to a data store 116 and a ledger 118. In some embodiments, data store 116 is configured to store data used during the operation of financial management system 102. Ledger 118 stores data associated with multiple financial transactions, such as asset transfers between two financial institutions. As discussed herein, ledger 118 is constructed in a manner that tracks when a transaction was initiated and who initiated the transaction. Thus, ledger 118 can track all transactions and generate an audit trail, as discussed herein. Using an audit server of the type described with respect to FIG. 6, financial management system 102 can support audit trails from both the financial management system and external systems and devices. In some embodiments, each transaction entry in ledger 118 records a client identifier, a hash of the transaction, an initiator of the transaction, and a time of the transaction. This data is useful in auditing the transaction data.

[0031] In some embodiments, ledger 118 is modeled after double-entry accounting systems where each transaction has two entries (i.e., one entry for each of the principals to the transaction). The entries in ledger 118 include data related to the principal parties to the transaction, a transaction date, a transaction amount, a transaction state, any relevant workflow reference, a transaction ID, and any additional metadata to associate the transactions with one or more external systems. The entries in ledger 118 also include cryptographic hashes to provide tamper resistance and auditability. Users for each of the principals to the transaction only have access to their own entries (i.e., the transactions to which the principal was a party). Access to the entries in ledger 118 can be further restricted or controlled based on a user's role or a party's role, where certain data is only available to certain roles.

[0032] In some embodiments, ledger 118 is a shared ledger that can be accessed by multiple financial institutions and other systems and devices. In particular implementations, both parties to a specific transaction can access all details related to that transaction stored in ledger 118. All details related to the transaction include, for example, the parties involved in the transaction, the type of transaction, the date and time of the transaction, the amount of the transaction, and other data associated with the transaction. Additionally, ledger 118 restricts permission to access specific transaction details based on relevant trades associated with a particular party. For example, if a specific party (such as a financial institution or other entity) requests access to data in ledger 118, that party can only access (or view) data associated with transactions to which the party was involved. Thus, a specific party cannot see data associated with transactions that are associated with other parties and do not include the specific party.

[0033] The shared permission aspects of ledger 118 provides for a subset of the ledger data to be replicated at various client nodes and other systems. The financial management systems and methods discussed herein allow selective replication of data. Thus, principals, financial institutions, and other entities do not have to hold data for transactions to which they were not a party.

[0034] It will be appreciated that the embodiment of FIG. 1 is given by way of example only. Other embodiments may include fewer or additional components without departing from the scope of the disclosure. Additionally, illustrated components may be combined or included within other components without limitation. In some embodiments, financial management system 102 may also be referred to as a “financial management platform,” “financial transaction system,” “financial transaction platform,” “asset management system,” or “asset management platform.”

[0035] In some embodiments, financial management system 102 interacts with authorized systems and authorized users. The authorized set of systems and users often reside outside the jurisdiction of financial management system 102. Typically, interactions with these systems and users are performed via secured channels. To ensure the integrity of financial management system 102, various constructs are used to provide system/platform integrity as well as data integrity.

[0036] In some embodiments, system/platform integrity is provided by using authorized (e.g., whitelisted) machines and devices, and verifying the identity of each machine using security certificates, cryptographic keys, and the like. In certain implementations, particular API access points are determined to ensure that a specific communication originates from a known enterprise or system. Additionally, the systems and methods described herein maintain a set of authorized users and roles, which may include actual users, systems, devices, or applications that are authorized to interact with financial management system 102. System/platform integrity is also provided through the use of secure channels to communicate between financial management system 102 and external systems. In some embodiments, communication between financial management system 102 and external systems is performed using highly secure TLS (Transport Layer Security) with well-established handshakes between financial management system 102 and the external systems. Particular implementations may use dedicated virtual private clouds (VPCs) for communication between financial management system 102 and any external systems. Dedicated VPCs offer clients the ability to set up their own security and rules for accessing financial management system 102. In some situations, an external system or user may use the DirectConnect network service for better service-level agreements and security.

[0037] In some embodiments financial management system 102 allows each client to configure and leverage their own authentication systems. This allows clients to set their custom policies on user identity verification (including 2FA (two factor authentication)) and account verification. An authentication layer in file management system 102
5 delegates requests to client systems and allows the financial management system to communicate with multiple client authentication mechanisms.

[0038] Financial management system 102 also supports role-based access control of workflows and the actions associated with workflows. Example workflows may include Payment vs Payment (PVP) and Delivery vs Payment (DVP) workflows. In some
10 embodiments, users can customize a workflow to add their own custom steps to integrate with external systems that can trigger a change in transaction state or associate them with manual steps. Additionally, system developers can develop custom workflows to support new business processes. In particular implementations, some of the actions performed by a workflow can be manual approvals, a SWIFT message request/response, scheduled or
15 time-based actions, and the like. In some embodiments, roles can be assigned to particular users and access control lists can be applied to roles. An access control list controls access to actions and operations on entities within a network. This approach provides a hierarchical way of assigning privileges to users. A set of roles also includes roles related to replication of data, which allows financial management system 102 to identify what
20 data can be replicated and who is the authorized user to be receiving the data at an external system.

[0039] In some embodiments, financial management system 102 detects and records all client metadata, which creates an audit trail for the client metadata. Additionally, one or more rules identify anomalies which may trigger a manual
25 intervention by a user or principal to resolve the issue. Example anomalies include system

request patterns that are not expected, such as a high number of failed login attempts, password resets, invalid certificates, volume of requests, excessive timeouts, http errors, and the like. Anomalies may also include data request patterns that are not expected, such as first time use of an account number, significantly larger than normal amount of
5 payments being requested, attempts to move funds from an account just added, and the like. When an anomaly is triggered, financial management system 102 is capable of taking a set of actions. The set of actions may initially be limited to pausing the action, notifying the principals of the anomaly, and only resuming activity upon approval from a principal.

10 **[0040]** FIG. 2 is a block diagram illustrating an embodiment of financial management system 102 configured to communicate with multiple other systems. As shown in FIG. 2, financial management system 102 may be configured to communicate with one or more CCPs (Central Counterpart Clearing Houses) 220, one or more exchanges 222, one or more banks 224, one or more asset managers 226, one or more
15 hedge funds 228, and one or more fast data ingestion systems (or “pipes”) 230. CCPs 220 are organizations that facilitate trading in various financial markets. Exchanges 222 are marketplaces in which securities, commodities, derivatives, and other financial instruments are traded. Banks 224 include any type of bank, credit union, savings and loan, or other financial institution. Asset managers 226 include asset management
20 organizations, asset management systems, and the like. In addition to hedge funds 228, financial management system 102 may also be configured to communicate with other types of funds, such as mutual funds. Financial management system 102 may communicate with CCPs 220, exchanges 222, banks 224, asset managers 226, and hedge funds 228 using any type of communication network and any communication protocol.
25 Fast data ingestion systems 230 include at least one data ingestion platform that consumes

trades in real-time along with associated events and related metadata. The platform is a high throughput pipe which provides an ability to ingest trade data in multiple formats. The trade data are normalized to a canonical format, which is used by downstream engines like matching, netting, real-time counts, and liquidity projections and optimizers. The platform also provides access to information in real-time to different parties of the trade.

[0041] Financial management system 102 includes secure APIs 202 that are used by partners to securely communicate with financial management system 102. In some embodiments, the APIs are stateless to allow for automatic scaling and load balancing. Role-based access controller 204 provide access to modules, data and activities based on the roles of an individual user or participant interacting with financial management system 102. In some embodiments, users belong to roles that are given permissions to perform certain actions. An API request may be checked against the role to determine whether the user has proper permissions to perform an action. An onboarding module 206 includes all of the metadata associated with a particular financial institution, such as bank account information, user information, roles, permissions, clearing groups, assets, and supported workflows. A clearing module 208 includes, for example, a service that provides the functionality to transfer assets between accounts within a financial institution. A settlement module 210 monitors and manages the settlement of funds or other types of assets associated with one or more transactions handled by financial management system 102.

[0042] Financial management system 102 also includes a ledger manager 212 that manages a ledger (e.g., ledger 118 in FIG. 1) as discussed herein. A FedWire, NSS (National Settlement Service), ACH (Automated Clearing House), Interchange module 214 provides a service used to interact with standard protocols like FedWire and ACH for the settlement of funds. A blockchain module 216 provides interoperability with

blockchains for settlement of assets on a blockchain. A database ledger and replication module 218 provides a service that exposes constructs of a ledger to the financial management system. Database ledger and replication module 218 provides functionality to store immutable transaction states with the ability to audit them. The transaction data
5 can also be replicated to authorized nodes for which they are either a principal or an observer. Although particular components are shown in FIG. 2, alternate embodiments of financial management system 102 may contain additional components not shown in FIG. 2, or may not contain some components shown in FIG. 2. Although not illustrated in FIG. 2, financial management system 102 may contain one or more processors, one or more
10 memory devices, and other components such as those discussed herein with respect to FIG. 14.

[0043] In the example of FIG. 2, various modules, components, and systems are shown as being part of financial management system 102. For example, financial management system 102 may be implemented, at least in part, as a cloud-based system. In
15 other examples, financial management system 102 is implemented, at least on part, in one or more data centers. In some embodiments, some of these modules, components, and systems may be stored in (and/or executed by) multiple different systems. For example, certain modules, components, and systems may be stored in (and/or executed by) one or more financial institutions.

20 [0044] As mentioned above, system/platform integrity is important to the secure operation of financial management system 102. This integrity is maintained by ensuring that all actions are initiated by authorized users or systems. Additionally, once an action is initiated and the associated data is created, an audit trail of any changes made and other information related to the action is recorded for future reference.

[0045] In particular embodiments, financial management system 102 includes (or interacts with) a roles database and an authentication layer. The roles database stores various roles of the type discussed herein.

[0046] FIG. 3 illustrates an embodiment 300 of an example asset transfer between two financial institutions. In the example of FIG. 3, financial management system 302 is in communication with a first bank 304 and a second bank 306. In this example, funds are being transferred from an account at bank 304 to an account at bank 306, as indicated by broken line 308. Bank 304 maintains a ledger 310 that identifies all transactions and data associated with transactions that involve bank 304. Similarly, bank 306 maintains a ledger 318 that identifies all transactions and data associated with transactions that involve bank 306. In some embodiments, ledgers 310 and 318 (or the data associated with ledgers 310 and 318) reside in financial management system 302 as a shared, permissioned ledger, such as ledger 118 discussed above with respect to FIG. 1.

[0047] In the example of FIG. 3, funds are being transferred out of an account 312 at bank 304. To facilitate the transfer of funds out of account 312, the funds being transferred are moved 316 from account 312 to a first suspense account 314 at bank 304. Each suspense account discussed herein is a “For Benefit Of” (FBO) account and is operated by the financial management system for the members of the network (i.e., all parties and principals). The financial management system may facilitate the transfer of assets into and out of the suspense accounts. However, the financial management system does not take ownership of the assets in the suspense accounts. The credits and debits associated with each suspense account are issued by the financial management system and the ledger (e.g., ledger 118 in FIG. 1) is used to track ownership of the funds in the suspense accounts. Each suspense account has associated governance rules that define how the suspense account operates. At bank 306, the transferred funds are received by a

second suspense account 322. The funds are moved 324 from second suspense account 322 to an account 320 at bank 306. In some embodiments, a suspense account may be referred to as a settlement account.

[0048] As discussed herein, financial management system 302 facilitates the
5 transfer of funds between bank 304 and 306. Additional details regarding the manner in which the funds are transferred are provided below with respect to FIG. 4. Although only one account and one suspense account is shown for each bank in FIG. 3, particular
10 embodiments of bank 304 and 306 may contain any number of accounts and suspense accounts. Additionally, bank 304 and 306 may contain any number of ledgers and other
15 systems. In some embodiments, each suspense account 314, 322 is established as part of the financial institution “onboarding” process with the financial management system. For example, the financial management system administrators may work with financial
institutions to establish suspense accounts that can interact with the financial management system as described herein.

[0049] In some embodiments, one or more components discussed herein are
15 contained in a traditional infrastructure of a bank or other financial institution. For example, an HSM (Hardware Security Module) in a bank may execute software or contain hardware components that interact with a financial management system to facilitate the
various methods and systems discussed herein. In some embodiments, the HSM provides
20 security signatures and other authentication mechanisms to authenticate participants of a transaction.

[0050] FIG. 4 illustrates an embodiment of a method 400 for transferring assets
(e.g., funds) between two financial institutions. Initially, a financial management system
receives 402 a request to transfer funds from an account at Bank A to an account at Bank
25 B. The request may be received by Bank A, Bank B, or another financial institution,

system, device, and the like. Using the example of FIG. 3, financial management system 302 receives a request to transfer funds from account 312 at bank 304 to account 320 at bank 306.

[0051] Method 400 continues as the financial management system confirms 404 available funds for the transfer. For example, financial management system 302 in FIG. 3 may confirm that account 312 at bank 304 contains sufficient funds to satisfy the amount of funds defined in the received transfer request. In some embodiments, if available funds are confirmed at 404, the financial management system creates suspense account A at Bank A and creates suspense account B at Bank B. In particular implementations, 10 suspense account A and suspense account B are temporary suspense accounts created for a particular transfer of funds. In other implementations, suspense account A and suspense account B are temporary suspense accounts but are used for a period of time (or for a number of transactions) to support transfers between bank A and bank B.

[0052] If available funds are confirmed at 404, then account A101 at Bank A is 15 debited 406 by the transfer amount and suspense account A (at Bank A) is credited with the transfer amount. Using the example of FIG. 3, financial management system 302 debits the transfer amount from account 312 and credits that transfer amount to suspense account 314. In some embodiments, ownership of the transferred assets changes as soon as the transfer amount is credited to suspense account 314.

[0053] The transferred funds are then settled 408 from suspense account A (at 20 Bank A) to suspense account B (at Bank B). For example, financial management system 302 in FIG. 3 may settle funds from suspense account 314 in bank 304 to suspense account 322 in bank 306. The settlement of funds between two suspense accounts is determined by the counterparty rules set up between the two financial institutions involved 25 in the transfer of funds. For example, a counterparty may choose to settle at the top of the

hour or at a certain threshold to manage risk exposure. The settlement process may be determined by the asset type, the financial institution pair, and/or the type of transaction. In some embodiments, transactions can be configured to settle in gross or net. For gross transaction settlement of a PVP workflow, the settlement occurs instantaneously over
5 existing protocols supported by financial institutions, such as FedWire, NSS, and the like. Netted transactions may also settle over existing protocols based on counterparty and netting rules. In some embodiments, the funds are settled after each funds transfer. In other embodiments, the funds are settled periodically, such as once an hour or once a day. Thus, rather than settling the two suspense accounts after each funds transfer between two
10 financial institutions, the suspense accounts are settled after multiple transfers that occur over a period of time. Alternatively, some embodiments settle the two suspense accounts when the amount due to one financial institution exceeds a threshold value.

[0054] Method 400 continues as suspense account B (at Bank B) is debited 410 by the transfer amount and account B101 at Bank B is credited with the transfer amount. For
15 example, financial management system 302 in FIG. 3 may debit suspense account 322 and credit account 320. After finishing step 410, the funds transfer from account 312 at bank 304 to account 320 at bank 306 is complete.

[0055] In some embodiments, the financial management system facilitates (or initiates) the debit, credit, and settlement activities (as discussed with respect to FIG. 4) by
20 sending appropriate instructions to Bank A and/or Bank B. The appropriate bank then performs the instructions to implement at least a portion of method 400. The example of method 400 can be performed with any type of asset. In some embodiments, the asset transfer is a transfer of funds using one or more traditional currencies, such as U.S. Dollars (USD) or Great British Pounds (GBP).

[0056] FIG. 5 illustrates an embodiment of a method 500 for authenticating a client and validating a transaction. Initially, a financial management system receives 502 a connection request from a client node, such as a financial institution, an authorized system, an authorized user device, or other client types mentioned herein. The financial management system authenticates 504 and, if authenticated, acknowledges the client node as known. Method 500 continues as the financial management system receives 506 a login request from the client node. In response to the login request, the financial management system generates 508 an authentication token and communicates the authentication token to the client node. In some embodiments, the authentication token is used to determine the identity of the user for future requests, such as fund transfer requests. The identity is then further checked for permissions to the various services or actions.

[0057] The financial management system further receives 510 a transaction request from the client node, such as a request to transfer assets between two financial institutions or other entities. In response to the received transaction request, the financial management system verifies 512 the client node's identity and validates the requested transaction. In some embodiments, the client node's identity is validated based on an authentication token, and then permissions are checked to determine if the user has permissions to perform a particular action or transaction. Transfers of assets also involve validating approval of an account by multiple roles to avoid compromising the network. If the client node's identity and requested transaction are verified, the financial management system creates 514 one or more ledger entries to store the details of the transaction. The ledger entries may be stored in a ledger such as ledger 118 discussed herein. The financial management system then sends 516 an acknowledgement regarding the transaction to the client node with a server transaction token. In some embodiments, the server transaction

token is used at a future time by the client when conducting audits. Finally, the financial management system initiates 518 the transaction using, for example, the systems and methods discussed herein.

[0058] In some embodiments, various constructs are used to ensure data integrity.

5 For example, cryptographic safeguards allow a transaction to span 1-n principals. The financial management system ensures that no other users (other than the principals who are parties to the transaction) can view data in transit. Additionally, no other user should have visibility into the data as it traverses the various channels. In some embodiments, there is a confirmation that a transaction was received completely and correctly. The

10 financial management system also handles failure scenarios, such as loss of connectivity in the middle of the transaction. Any data transmitted to a system or device should be explicitly authorized such that each entry (e.g., ledger entry) can only be seen and read by the principals who were a party to the transaction. Additionally, principals can give permission to regulators and other individuals to view the data selectively.

15 [0059] Cryptographic safeguards are used to detect data tampering in the financial management system and any other systems or devices. Data written to the ledger and any replicated data may be protected by:

[0060] – Stapling all the events associated with a single transaction.

[0061] – Providing logical connections of each commit to those that came before it

20 are made.

[0062] – The logical connections are also immutable but principals can send messages for relinking. In this case, the current and all preceding links are maintained. For example, trade amendments are quite common. A trade amendment needs to be connected to the original trade. For forensic analysis, a bank may wish to identify all

trades by a particular trader. Query characteristics will be graphs, time series, and RDBMS (Relational Database Management System).

[0063] In some embodiments, the financial management system monitors for data tampering. If the data store (central data store or replicated data store) is compromised in any way and the data is altered, the financial management system should be able to detect exactly what changed. Specifically, the financial management system should guarantee all participants on the network that their data has not been compromised or changed. Information associated with changes are made available via events such that the events can be sent to principals via messaging or available to view on, for example, a user interface.

10 Regarding data forensics, the financial management system is able to determine that the previous value of an attribute was X, it is now Y and it was changed at time T, by a person A. If a system is hacked or compromised, there may be any number of changes to attribute X and all of those changes are captured by the financial management system, which makes the tampering evident.

15 [0064] In particular embodiments, the financial management system leverages the best security practices for SaaS (Software as a Service) platforms to provide cryptographic safeguards for ensuring integrity of the data. For ensuring data integrity, the handshake between the client and an API server (discussed with respect to FIG. 6) establish a mechanism which allows both the client and the server to verify the authenticity of transactions independently. Additionally, the handshake provides a mechanism for both

20 the client and the server to agree on a state of the ledger. If a disagreement occurs, the ledger can be queried to determine the source of the conflict.

[0065] FIG. 6 is a block diagram illustrating an embodiment 600 of a financial management system 602 interacting with an API server 608 and an audit server 610.

25 Financial management system 602 also interacts with a data store 604 and a ledger 606. In

some embodiments, data store 604 and ledger 606 are similar to data store 116 and ledger 118 discussed herein with respect to FIG. 1. In particular implementations, API server 608 exposes functionality of financial management system 602, such as APIs that provide reports of transactions and APIs that allow for administration of nodes and counterparties.

5 Audit server 610 periodically polls the ledger to check for data tampering of ledger entries. This check of the ledger is based on, for example, cryptographic hashes and are used to monitor data tampering as described herein.

[0066] In some embodiments, all interactions with financial management system 602 or the API server are secured with TLS. API server 608 and audit server 610 may

10 communicate with financial management system 602 using any type of data communication link or data communication network, such as a local area network or the Internet. Although API server 608 and audit server 610 are shown in FIG. 6 as separate components, in some embodiments, API server 608 and/or audit server 610 may be incorporated into financial management system 602. In particular implementations, a

15 single server may perform the functions of API server 608 and audit server 610.

[0067] In some embodiments, at startup, a client sends a few checksums it has sent and transaction IDs to API server 608, which can verify the checksums and transaction IDs, and take additional traffic from the client upon verification. In the case of a new client, mutually agreed upon seed data is used at startup. A client request may be

20 accompanied by a client signature and, in some cases, a previous signature sent by the server. The server verifies the client request and the previous server signature to acknowledge the client request. The client persists the last server signature and a random set of server hashes for auditing. Both client and server signatures are saved with requests to help quickly audit correctness of the financial management system ledger. The block

25 size of transactions contained in the request may be determined by the client. A client

SDK (Software Development Kit) assists with the client server handshake and embedding on server side signatures. The SDK also persists a configurable amount of server signatures to help with restart and for random audits. Clients can also set appropriate block size for requests depending on their transaction rates. The embedding of previous server signatures in the current client block provides a way to chain requests and provide an easy mechanism to detect tampering. In addition to a client-side signature, the requests are encrypted using standard public key cryptography to provide additional defense against client impersonation. API server 608 logs all encrypted requests from the client. The encrypted requests are used, for example, during data forensics to resolve any disputes.

[0068] In particular implementations, a client may communicate a combination of a previous checksum, a current transaction, and a hash of the current transaction to the financial management system. Upon receipt of the information, the financial management system checks the previous checksum and computes a new checksum, and stores the client hash, the current transaction, and the current checksum in a storage device, such as data store 604. The checksum history and hash (discussed herein) protect the integrity of the data. Any modification to an existing row in the ledger cannot be made easily because it would be detected by mismatched checksums in the historical data, thereby making it difficult to alter the data.

[0069] The integrity of financial management system 602 is ensured by having server audits at regular intervals. Since financial management system 602 uses chained signatures per client at the financial management system, it ensures that an administrator of financial management system 602 cannot delete or update any entries without making the ledger tamper evident. In some embodiments, the auditing is done at two levels: a minimal level which the SDK enforces using a randomly selected set of server signatures

to perform an audit check; and a more thorough audit check run at less frequent intervals to ensure that the data is correct.

[0070] In some implementations, financial management system 602 allows for the selective replication of data. This approach allows principals or banks to only hold data
5 for transactions they were a party to, while avoiding storage of other data related to transactions in which they were not involved. Additionally, financial management system 602 does not require clients to maintain a copy of the data associated with their transactions. Clients can request the data to be replicated to them at any time. Clients can verify the authenticity of the data by using the replicated data and comparing the signature
10 the client sent to the financial management system with the request.

[0071] In some embodiments, a notarial system is used to maintain auditability and forensics for the core systems. Rather than relying on a single notary hosted by the financial management system, particular embodiments allow the notarial system to be installed and executed on any system that interacts with the financial management system
15 (e.g., financial institutions or clients that facilitate transactions initiated by the financial management system).

[0072] The systems and methods discussed herein support different asset classes. Each asset class may have a supporting set of metadata characteristics that are distinct. Additionally, the requests and data may be communicated through multiple “hops”
20 between the originating system and the financial management system. During these hops, data may be augmented (e.g., adding trade positions, account details, and the like) or changed.

[0073] In certain types of transactions, such as cash transactions, the financial management system streamlines the workflow by supporting rich metadata accompanying

each cash transfer. This rich metadata helps banks tie back cash movements to trades, accounts, and clients.

[0074] As discussed herein, the described systems and methods facilitate the movement of assets between principals (also referred to as “participants”). The participants are typically large financial institutions in capital markets that trade multiple financial products. Trades in capital markets can be complex and involve large asset movements (also referred to as “settlements”). The systems and methods described herein can integrate to financial institutions and central settlement authorities such as the US Federal Reserve or DTCC (Depository Trust & Clearing Corporation) to facilitate the final settlement of assets. The described systems and methods also have the ability to execute workflows such as DVP, threshold based settlement, or time-based settlement between participants. Using the workflows, transactions are settled in gross or net amounts.

[0075] The systems and methods described herein include a platform and workflow to support and enable 3rd party guarantors the ability to view payment activity between participants in real time (or substantially real time), and step in to make payments on behalf of participants when necessary.

[0076] The ACH (Automated Clearing House) payment service enables companies to electronically collect payments from customers for either one-off or recurring payments by directly debiting a customer's checking or saving accounts. Common uses of ACH include online bill payment, mortgage and loan repayment, and direct deposit of payroll. Also, many investment managers and brokerage firms allow users to link a bank account or an online funding source to a trading account.

[0077] Traditionally, connecting directly to bank accounts has been preferred for the following reasons:

[0078] 1. Lower cost to transfer money using ACH versus paper checks or credit cards

[0079] 2. Ability to move large amounts of money

[0080] 3. Fewer instances of fraud from bank accounts compared to credit cards

5 [0081] As used herein, a retail payment is considered a movement of amounts smaller than \$100,000 (although this can be any amount). Typically, retail payments in and out of a bank account are settled over settlement venues and protocols such as ACH in the U.S., SEPA (Single Euro Payments Area), NACH in India, etc. These payments have the following advantages:

10 [0082] Low Costs

[0083] Ability to schedule automatic payments

[0084] Ability to issue a debit pull or credit push

[0085] Despite the advantages mentioned above, ACH has the following disadvantages:

15 [0086] Inability to determine the validity of the account (this is possible if the user has closed the bank account at a later point in time)

[0087] Inability to determine the balance in the account even if valid (are there sufficient funds to cover the transaction?)

[0088] Slow multi-phased settlement protocol that can take hours or even days

20 [0089] Various Reject codes and ability to recall the payments later by the account holder

[0090] In some situations, rejections in payments are in the range of 1 - 10% depending on the type of products that are being purchased. For example, certain types of product purchases (e.g., electronics, jewelry, and the like) are more prone to fraud.

25 [0091] Adding a funding source and moving money

[0092] In some situations, online sites and other vendors perform the following steps when linking a bank account.

[0093] 1. Select a bank from a list of popular retail banks using either of the following:

5 [0094] A. IAV (Instant Account Verification) process. This is done by asking the user to submit the username and password for the bank (or account). The website or process then proceeds to use these credentials to log in on behalf of the user to validate the account. Since the bank credentials are being required by the site, many users are comfortable sharing this information with well reputed companies or financial institutions.

10 [0095] B. Micro Deposits: The website or process follows a multi-step procedure as follows:

[0096] i. The user enters the account number and routing number of their banking institution.

15 [0097] ii. The website or process then makes two or more deposits of small amounts, typically less than \$0.25, using the account number and routing number.

[0098] iii. If the above step fails, the account number and routing number are considered to be incorrect and the user has to return to the beginning of the process to add a funding source. If there is no error, the process proceeds to the next step.

20 [0099] iv. The user comes back to the website or process to complete the addition of the bank account as the funding source by validating the two micro deposit amounts. The fact that the user knew their account number and the routing number, and then was able to accurately validate the two micro deposits is enough proof that the user is indeed the owner of the account. In addition, it also satisfies the BSA (Bank Secrecy Act) requirement for the website or process.

[00100] 2. Once the bank account has been added as a funding source, the website or process will attempt to debit money from or credit money to the account. Debits are done when the website or process attempts to “pull” money from the account to complete a transaction. Credits are done when the website or process allows the user to “push” money to their bank account. This is done when the website or process has an associated product that allows the user to hold money in their account. This can be for online payments products, brokerage accounts, tax products, auction sites, mortgage or rent payments, and the like.

[00101] 3. Payments in and out of the bank account can be done as a debit-pull or a credit-push. A debit-pull in the case above is when the company or user attempts to pull a debit from the bank account. A credit-push is when the user authorizes their bank to push funds to a receiver (in this case, the company).

[00102] 4. In many existing systems, payments are completed over ACH or equivalent methods. The initiator is called the originator of the request. The banking regulations require that the originator be a financial institution and is typically called the ODFI (Originating Depository Financial Institution) and the receiver is called the RDFI (Requesting Depository Financial Institution).

[00103] A. In the case of a debit-pull, the ODFI is requesting a debit from the other institution.

[00104] B. In the case of a credit-push, the ODFI pushes money to the RDFI.

[00105] 5. In most cases (but not always), the risk is higher on the ODFI as it is the originator of the request.

[00106] Problems with rejections in payments

[00107] The steps needed to validate a bank account as a funding source are discussed above, as well as the attempt to do a debit-pull. During the attempt to pull

funds, there can be failures which can lead to a direct economic loss for the companies.

The following is an illustrative example using an example company brokerage firm ABC-Trading Inc.

[00108] 1. A customer of ABC Trading adds a bank account as a funding source for
5 their trades and allows ABC Trading to pull and push funds based on their trading activity
with the brokerage firm.

[00109] 2. The customer instructs ABC Trading to buy \$5,000 worth of a stock and
does not have sufficient balance in their brokerage account to cover the purchase.

[00110] 3. ABC Trading makes the stock purchase and then must initiate a “pull” of
10 \$5,000 from the customer’s bank account.

[00111] 4. ABC Trading initiates a debit-pull by issuing ACH debit instructions to
its ODFI. In some cases, ABC Trading may be a bank and can be the ODFI. In other
cases, the firm may choose one or more banks where it has a banking relationship to
originate the ACH request for them. This can happen on T+0 or T+1 days depending on
15 the cut off time for the ODFI.

[00112] 5. The ACH debit instructions can be rejected anywhere from T+0 to T+4
days.

[00113] 6. If at any point, the ACH transfer is rejected, ABC Trading will need to
undo the transaction and may be subject to losses if the stock has lost value. There are
20 also operational costs associated with tracking down the funds from the customer.

[00114] The steps above may be repeated many thousands of times per day
depending on the size of the broker. The process is similar for other companies that offer
services such as bill payments, mortgage payments, or online peer-to-peer payment. The
firm takes the risk of an unsuccessful debit from point T+0 to T+4 days when the request

is complete. The rejections, despite the successful validation of the account, are due to the following:

[00115] A. Inability to validate the account at point T+0: It is possible that the account may have been closed by the user. ABC Trading has no information about the closure of the account at point T+0. Following the closure of the account, any attempt to debit the amounts from the account will result in a rejection.

[00116] B. Insufficient balance in the account: The account did not have sufficient balance to complete the request. In the example above, the account did not have \$5000.

[00117] C. Other errors: There are several reject codes that NACHA supports.

10 [00118] On demand payments

[00119] The systems and methods discussed herein include a hardware and/or software platform that facilitates the movement of assets between principals. In some embodiments, the participants are large financial institutions in capital markets that trade multiple financial products. Trades in capital markets can be complex and involve large asset movements (also referred to as “settlements”). The clearing and settlement gateway discussed herein can integrate to financial institutions and central settlement authorities such as the U.S. Federal Reserve, DTC, and the like to facilitate the final settlement of assets.

[00120] In some embodiments, the systems and methods described herein have the following core components:

[00121] 1. Clearing and Settlement Gateway: This is used to integrate to the core ledgers of the banks and settlement agencies to initiate and execute clearing and settlement.

[00122] 2. Permissioned Shared Ledger: When an asset is cleared or settled, it goes through several “state changes.” The permissioned shared ledger records the state changes and makes it available to the permissioned parties in substantially real time.

[00123] 3. Workflows: Parties in a trade can execute complex settlement instructions that determine the sequence of steps that must be followed to effect the movement of assets between participants. The described systems and methods facilitate this with various workflows. In some embodiments, execution of a workflow will result in multiple instructions that are sent and received through the clearing and settlement gateway and multiple records in the permissioned shared ledger.

[00124] The payments platform discussed herein provides a practical solution to solve the problems mentioned above.

[00125] In some embodiments, the number of funding sources and the amounts of monies moved from these funding sources follows a 80-20 rule. That is, 80% of the money movement happens from 10 or fewer banks. A solution that addresses 80% of the problem will significantly reduce the risks for companies.

[00126] FIG. 7 illustrates an embodiment of an example financial environment 700. As shown in FIG. 7, three banks 702, 704, and 706 are coupled to a central bank 708 and an investment manager 710. Account holders 712 are associated with investment manager 710. IN some embodiments, account holders 712 are clients of (or represented by) investment manager 710. Three accounts 714, 716, and 718 are shown in bank 702, although bank 702 may have any number of accounts. Similarly, three accounts 720, 722, and 724 are shown in bank 704, although bank 704 may have any number of accounts. Bank 706 includes an investment manager receiving account 726. In some embodiments, investment manager receiving account 726 stores funds received by or managed by investment manager 710.

[00127] In some embodiments, accounts 714, 716, 718 reside within the context of a ledger of bank 702. Similarly, accounts 720, 722, 724 reside within the context of a ledger of bank 704. The most practical way to address the issues discussed herein involve the following:

5 [00128] 1. Query the ledger of a bank in real time to determine if the account is valid.

[00129] 2. Query the ledger of the bank to determine if the account has sufficient balance.

10 [00130] 3. Earmark money or debit funds and hold them in an escrow or settlement account to ensure “Good funds.”

[00131] 4. Transfer the money from the account of the user to the account of the firm.

[00132] FIG. 8 is a block diagram illustrating an environment 800 within which an example embodiment may be implemented. As shown in FIG. 8, a first bank 802 has
15 three accounts 814, 816, and 818 as well as a settlement account 820 (also referred to as a suspense account). Similarly, a second bank 804 has three accounts 822, 824, and 826 as well as a settlement account 828 (also referred to as a suspense account). A third bank 806 has an investment manager concentration account 830, which may be used by an investment manager 812 to facilitate the processing and settlement of one or more
20 customer transactions. A central bank 808 communicates with the banks 802, 804, and 806. A financial management system 810 communicates with banks 802 and 804. Additionally, financial management system 810 communicates with investment manager 812. In some embodiments, financial management system 810 is similar to the systems discussed herein with respect to FIGs. 1-6.

[00133] As shown in FIG. 8, lines 832 and 834 represent instructions issued by financial management system 810 to first bank 802 and second bank 804, respectively. The instructions 832, 834 may include, for example, settlement instructions associated with one or more accounts (814, 816, 818, 822, 824, 826) or settlement accounts 820, 828. 5 Additionally, lines 836 and 838 in FIG. 8 represent, for example, settlement instructions issued by first bank 802 and second bank 804, respectively, to central bank 808. Line 840 represents, for example, instructions to make funds available in the investment manager concentration account 830.

10 [00134] FIG. 9 illustrates an embodiment of a method 900 for implementing a transfer request. In some embodiments, method 900 is performed with respect to the environment shown in FIG. 8. Initially, a user (or system) initiates 902 a workflow associated with a transfer request that identifies a source account and a destination account. For example, an investment manager (or other subscriber to the systems and 15 methods discussed herein) may initiate a workflow for a transfer request. This can be done in batch or individually. In some embodiments, the process can be set to run automatically throughout the day based on thresholds or timing set by the investment manager. An example transfer request may be a request to purchase a product or service, such as a request to purchase a stock or other security. A financial management system of 20 the type discussed herein confirms 904 that the source account is valid and confirms 906 that the source account has a sufficient balance for the transfer request. In some embodiments, validation of the source account and confirmation that the source account has a sufficient balance for the transfer request is performed in substantially real time. Thus, the confirmations 904 and 906 are performed quickly before any goods, services, or 25 assets are transferred to a purchasing party. In the case of a batch processing, the systems

and methods discussed herein confirm the account validity and sufficient balance checks for each account included in the batch.

[00135] Method 900 continues as the financial management system issues 908 instructions to debit the source account and credit a settlement account (or a suspense
5 account). In particular embodiments, the source account is a client account and the settlement account is an investment manager settlement account. The method then determines 910 whether the confirmations 904 and 906 were successful (e.g., the source account is confirmed as valid and has a sufficient balance for the transfer request). If either one of the confirmations 904 or 906 fails, then the financial management system
10 notifies 912 the owner of the destination account (or the initiator of the transfer request workflow (e.g., the investment manager)) that the transfer request failed. For example, a notification may be communicated to an individual or entity associated with the destination account.

[00136] If both of the confirmations 904 or 906 were successful, the financial
15 management system sends 914 settlement instructions to move funds to the destination account. In some embodiments, funds are moved from the settlement account to a concentration account at another bank (e.g., investment manager concentration account 830 shown in FIG. 8). Finally, the funds are moved 916 to the destination account. In some embodiments, the funds are moved in response to a bank issuing wire transfer
20 instructions or other funds transfer instructions.

[00137] In some embodiments, one or more entities are onboarded (e.g., set up) in the financial management systems and methods discussed herein. The onboarding process includes creation of identities and other information associated with each entity. The entities may include, for example, organizations, companies, participants, regulators, and
25 the like. The following description includes example steps involved in the onboarding

process and describes how the process influences the integration with the underlying systems of these entities.

[00138] FIG. 10 illustrates an embodiment of an example configuration 1000 of multiple nodes and a distributed transaction store. As shown in FIG. 10, two nodes 1002 and 1004 are coupled to a distributed transaction store 1006. Nodes 1002 and 1004 may represent organizations, companies, participants, regulators, individuals, and the like. Although two nodes 1002, 1004 are shown in FIG. 10, particular embodiments may include any number of nodes coupled to any number of distributed transaction stores. Distributed transaction store 1006 may store various transaction-related data associated with any number of nodes 1002, 1004 as well as transaction data associated with other entities or systems.

[00139] Onboarding

[00140] Onboarding refers to the process of configuring a new entity, such as an organization, to interact with the various financial management systems and methods discussed herein. An onboarded entity is assigned a unique identification in the financial management systems discussed herein and has its identity details configured, which allows it to uniquely sign the transactions for the underlying ledger.

[00141] Setup

[00142] The onboarding process involves registering a new node (e.g., node 1002 or 1004) in the financial management systems and methods discussed herein. In some embodiments, a node is a virtual entity that corresponds to a legal entity in the real world. In addition to common metadata such as a name, type (direct, indirect, observer, and the like), and the like, the node setup involves providing a globally unique identifier for the node. This unique identifier can be used to refer to the node across the financial management system. A node can be searched in a directory either by using its name or its

unique identifier. The setup process involves installing digital certificates that can identify the node in the financial management ecosystem as well as among its participants.

[00143] Authentication of participants and their transactions is achieved with a Public Key Infrastructure. Each participant will set up an Admin identity to control
5 issuance of certificates to its users. The users can enroll with their organization's Certificate Authority and use their private key and certificate to sign transactions and identify themselves.

[00144] Adaptors

[00145] While a node is a virtual entity configured in the financial management
10 ecosystem, it can have its own legacy or current system backed by a data store to carry out its process. In some embodiments, integration to these systems are carried out by "adaptors" that are associated with the node. For example, adaptors can be software and/or hardware modules that are typically custom-developed, installed, and configured as part of the node. In particular implementations, the configuration process involves
15 capturing a protocol of communication, capturing connectivity details that are specific to the protocol, and setting up identities. An important step, discussed herein, is the setting up of identities. This may involve importing or re-configuring the identity details such as certificates that are required to identify the node and its users in the existing legacy system. For example, this can involve the signatures used to sign the transactions in their
20 internal DLT (Distributed Ledger Technology).

[00146] FIG. 11 illustrates another embodiment of an example configuration 1100 of multiple nodes and a distributed transaction store. As shown in FIG. 11, two nodes 1102 and 1104 are coupled to a distributed transaction store 1106. Nodes 1102 and 1104 may represent organizations, companies, participants, regulators, individuals, and the like.
25 Although two nodes 1102, 1104 are shown in FIG. 11, particular embodiments may

include any number of nodes coupled to any number of distributed transaction stores.

Distributed transaction store 1106 may store various transaction-related data associated with any number of nodes 1102, 1104 as well as transaction data associated with other entities or systems.

5 **[00147]** In the example configuration of FIG. 11, node 1102 has its own data store 1108 (e.g., a local data store) and node 1104 has its own data store 1110. Additionally, node 1102 has an associated adaptor 1112 and node 1104 has an associated adaptor 1114, as discussed herein.

[00148] Push vs Pull model

10 **[00149]** As shown in FIG. 11, the custom adaptor modules (e.g., 1112 and 1114) can follow either a push model or a pull model. In the former mode, the adaptor is listening for updates happening in the underlying system and the same gets propagated into the financial management ecosystem discussed herein. In the latter case, the adaptor pulls the necessary details and pushes them into the node.

15 **[00150]** Events

[00151] In addition to transactions, the adaptor can also listen to and raise events that are relevant to the process being automated. Thus, the adaptor is both a publisher as well as a subscriber for the events in the underlying service.

[00152] The systems and methods described herein use a tiered architecture that can
20 scale up to requests for clearing and settlement. The architecture provides for an auto scaled architecture where micro services such as clearing services can scale up or shrink depending on the requests to the architecture.

[00153] The described systems and methods maintain a history of all transactions within the network. In some embodiments, the systems and methods provide a query
25 interface for participants to search for parts of the ledger. Additionally, the systems and

methods have a subscription based interface for the participants to subscribe to changes in the network in real time (or substantially real time). The following are important aspects of the ledger: transaction states, securing the ledger entries, querying and subscribing to the ledger, and ledger replication.

5 **[00154]** Transaction states are initiated on the request of the participants or when a trigger-based clearing or settlement is set by the participants. A transaction has various states that it passes through from the initial state to the terminal state. The transaction and the associated states have additional metadata. The ledger records all of the state changes for a transaction. For each transaction, multiple records are stored to show the state
10 changes. In some embodiments, this record is not updated. By default, all transactions are final and irreversible. Some transactions may have been created in error (“fat finger”). For such transaction to be reversed, a new transaction is initiated. The metadata for the new transaction includes a reference to the transaction that needs to be reversed. The parties are informed on the request to reverse the transaction as part of a new transaction.
15 The new transaction also goes through the state changes discussed herein. When completed, the metadata of the initial transaction is also updated (making that mutable for this scenario).

[00155] FIG. 12 illustrates an example state diagram 1200 showing various states that a transaction may pass through. As shown in FIG. 12, a particular transaction may be
20 initiated (“new”), then clearing is initiated with a bank, after which the transaction’s state is “clearing pending.” The next transaction state is “cleared”, then settlement is initiated, after which the transaction state is “settlement pending.” After the transaction has settled, the state becomes “completed.” As shown in state diagram 1200, the state diagram may branch to “cancelled” at locations in the state diagram. For example, a transaction may be
25 cancelled due to insufficient funds, a mutual decision to reverse the transaction before

settlement, a bank internal ledger failure, and the like. Additionally, the state diagram may branch to “rolled back” at multiple locations. For example, a transaction may be rolled back due to an unrecoverable error, a cancellation of the transaction, and the like.

[00156] Each transaction and the associated transaction states may have additional
5 metadata. The shared ledger (e.g., ledger 118 in FIG. 1) may contain all the state information and state changes for a transaction. A separate record is maintained for each state of the transaction. The record is not updated or modified. In some embodiments, all transactions are final and irreversible. The metadata for the new transaction includes a
10 reference to the erroneous transaction that needs to be reversed. The parties are informed of the request to reverse the erroneous transaction as part of a new transaction. The new transaction also goes through the state changes shown in FIG. 12. When the new transaction is completed, the metadata of the initial transaction is also updated.

[00157] In some embodiments, the transactions and the metadata recorded in the shared permissioned ledger contain information that are very sensitive and confidential to
15 the businesses initiating the instructions. The systems and methods described herein maintain the security of this information by encrypting data for each participant using a symmetric key that is unique to the participant. In some embodiments, the keys also have a key rotation policy where the data for that node is rekeyed. The keys for each node are bifurcated and saved in a secure storage location with role-based access controls. In some
20 embodiments, only a special service called a cryptographic service can access these keys at runtime to encrypt and decrypt the data.

[00158] FIG. 13 is a block diagram illustrating an embodiment 1300 of a financial management system 1302 interacting with a cryptographic service 1308 and multiple
client nodes 1304 and 1306. Although two client nodes 1304, 1306 are shown in FIG. 13,
25 alternate embodiments may include any number of client nodes coupled to financial

management system 1302. In the embodiment of FIG. 13, financial management system 1302 communicates with client nodes 1304, 1306 to manage one or more transactions between client nodes 1304 and 1306, or between one of client nodes 1304, 1306 and other client nodes, devices, or systems (not shown). Financial management system 1302 also
5 communicates with cryptographic service 1308, which manages secure access to a data store 1314. In some embodiments, data store 1314 is a shared ledger (e.g., ledger 118 in FIG. 1) of the type discussed herein. In these embodiments, data store 1314 represents the capabilities of the shared ledger as they relate to data permissions.

[00159] As shown in FIG. 13, data store 1314 stores encrypted data associated with
10 client nodes 1304 and 1306. In alternate embodiments, data store 1314 may store encrypted data associated with any number of client nodes. Cryptographic service 1308 ensures security of the data in data store 1314 using, for example, secure bifurcated keys that are stored in node 1 key storage 1310 and node 2 key storage 1312. Each key is unique for the associated client node. When financial management system 1302 wants to
15 access data from data store 1314, the data access request must include an appropriate key to ensure that the data access request is authorized.

[00160] Each transaction can have two or more participants. In addition to the multiple parties involved in the transaction, there can be one or more “observers” to the transaction. The observer status is important from a compliance and governance
20 standpoint. For example, the Federal Reserve or the CFTC is not a participant of the transaction, but may have observer rights on certain type of transactions in the system. In some embodiments the participants can subscribe to certain types of events. The transaction state in the state diagram above changes trigger events in the described systems.

[00161] FIG. 14 is a block diagram illustrating an example computing device 1400. Computing device 1400 may be used to perform various procedures, such as those discussed herein. Computing device 1400 can function as a server, a client, a client node, a financial management system, or any other computing entity. Computing device 1400
5 can be any of a wide variety of computing devices, such as a workstation, a desktop computer, a notebook computer, a server computer, a handheld computer, a tablet, a smartphone, and the like. In some embodiments, computing device 1400 represents any of the computing devices discussed herein.

[00162] Computing device 1400 includes one or more processor(s) 1402, one or
10 more memory device(s) 1404, one or more interface(s) 1406, one or more mass storage device(s) 1408, and one or more Input/Output (I/O) device(s) 1410, all of which are coupled to a bus 1412. Processor(s) 1402 include one or more processors or controllers that execute instructions stored in memory device(s) 1404 and/or mass storage device(s) 1408. Processor(s) 1402 may also include various types of computer-readable media, such
15 as cache memory.

[00163] Memory device(s) 1404 include various computer-readable media, such as volatile memory (e.g., random access memory (RAM)) and/or nonvolatile memory (e.g., read-only memory (ROM)). Memory device(s) 1404 may also include rewritable ROM, such as Flash memory.

[00164] Mass storage device(s) 1408 include various computer readable media,
20 such as magnetic tapes, magnetic disks, optical disks, solid state memory (e.g., Flash memory), and so forth. Various drives may also be included in mass storage device(s) 1408 to enable reading from and/or writing to the various computer readable media. Mass storage device(s) 1408 include removable media and/or non-removable media.

[00165] I/O device(s) 1410 include various devices that allow data and/or other information to be input to or retrieved from computing device 1400. Example I/O device(s) 1410 include cursor control devices, keyboards, keypads, microphones, monitors or other display devices, speakers, printers, network interface cards, modems, lenses, 5 CCDs or other image capture devices, and the like.

[00166] Interface(s) 1406 include various interfaces that allow computing device 1400 to interact with other systems, devices, or computing environments. Example interface(s) 1406 include any number of different network interfaces, such as interfaces to local area networks (LANs), wide area networks (WANs), wireless networks, and the 10 Internet.

[00167] Bus 1412 allows processor(s) 1402, memory device(s) 1404, interface(s) 1406, mass storage device(s) 1408, and I/O device(s) 1410 to communicate with one another, as well as other devices or components coupled to bus 1412. Bus 1412 represents one or more of several types of bus structures, such as a system bus, PCI bus, IEEE 1394 15 bus, USB bus, and so forth.

[00168] For purposes of illustration, programs and other executable program components are shown herein as discrete blocks, although it is understood that such programs and components may reside at various times in different storage components of computing device 1400, and are executed by processor(s) 1402. Alternatively, the systems 20 and procedures described herein can be implemented in hardware, or a combination of hardware, software, and/or firmware. For example, one or more application specific integrated circuits (ASICs) can be programmed to carry out one or more of the systems and procedures described herein.

[00169] In the above disclosure, reference has been made to the accompanying 25 drawings, which form a part hereof, and in which is shown by way of illustration specific

implementations in which the disclosure may be practiced. It is understood that other implementations may be utilized and structural changes may be made without departing from the scope of the present disclosure. References in the specification to “one embodiment,” “an embodiment,” “an example embodiment,” “selected embodiments,” “certain embodiments,” etc., indicate that the embodiment or embodiments described may include a particular feature, structure, or characteristic, but every embodiment may not necessarily include the particular feature, structure, or characteristic. Additionally, such phrases are not necessarily referring to the same embodiment. Further, when a particular feature, structure, or characteristic is described in connection with an embodiment, it is submitted that it is within the knowledge of one skilled in the art to affect such feature, structure, or characteristic in connection with other embodiments whether or not explicitly described.

[00170] Implementations of the systems, devices, and methods disclosed herein may comprise or utilize a special purpose or general-purpose computer including computer hardware, such as, for example, one or more processors and system memory, as discussed herein. Implementations within the scope of the present disclosure may also include physical and other computer-readable media for carrying or storing computer-executable instructions and/or data structures. Such computer-readable media can be any available media that may be accessed by a general purpose or special purpose computer system. Computer-readable media that store computer-executable instructions are computer storage media (devices). Computer-readable media that carry computer-executable instructions are transmission media. Thus, by way of example, and not limitation, implementations of the disclosure can include at least two distinctly different kinds of computer-readable media: computer storage media (devices) and transmission media.

[00171] Computer storage media (devices) includes RAM, ROM, EEPROM, CD-ROM, solid state drives (“SSDs”) (e.g., based on RAM), Flash memory, phase-change memory (“PCM”), other types of memory, other optical disk storage, magnetic disk storage or other magnetic storage devices, or any other medium which can be used to store
5 desired program code means in the form of computer-executable instructions or data structures and which can be accessed by a general purpose or special purpose computer.

[00172] An implementation of the devices, systems, and methods disclosed herein may communicate over a computer network. A “network” is defined as one or more data links that enable the transport of electronic data between computer systems and/or
10 modules and/or other electronic devices. When information is transferred or provided over a network or another communications connection (either hardwired, wireless, or a combination of hardwired and wireless) to a computer, the computer properly views the connection as a transmission medium. Transmissions media can include a network and/or data links, which can be used to carry desired program code means in the form of
15 computer-executable instructions or data structures and which can be accessed by a general purpose or special purpose computer. Combinations of the above should also be included within the scope of computer-readable media.

[00173] Computer-executable instructions include, for example, instructions and
20 data which, when executed at a processor, cause a general purpose computer, special purpose computer, or special purpose processing device to perform a certain function or group of functions. The computer-executable instructions may be, for example, binaries, intermediate format instructions such as assembly language, or even source code. Although the subject matter has been described in language specific to structural
25 features and/or methodological acts, it is to be understood that the subject matter defined

in the appended claims is not necessarily limited to the described features or acts described above. Rather, the described features and acts are disclosed as example forms of implementing the claims.

[00174] Those skilled in the art will appreciate that the disclosure may be practiced
5 in network computing environments with many types of computer system configurations, including, personal computers, desktop computers, laptop computers, message processors, hand-held devices, multi-processor systems, microprocessor-based or programmable consumer electronics, network PCs, minicomputers, mainframe computers, mobile telephones, PDAs, tablets, pagers, routers, switches, various storage devices, and the
10 like. The disclosure may also be practiced in distributed system environments where local and remote computer systems, which are linked (either by hardwired data links, wireless data links, or by a combination of hardwired and wireless data links) through a network, both perform tasks. In a distributed system environment, program modules may be located in both local and remote memory storage devices.

15 [00175] Further, where appropriate, functions described herein can be performed in one or more of: hardware, software, firmware, digital components, or analog components. For example, one or more application specific integrated circuits (ASICs) can be programmed to carry out one or more of the systems and procedures described herein. Certain terms are used throughout the description and claims to refer to particular
20 system components. As one skilled in the art will appreciate, components may be referred to by different names. This document does not intend to distinguish between components that differ in name, but not function.

[00176] It should be noted that the sensor embodiments discussed above may comprise computer hardware, software, firmware, or any combination thereof to perform
25 at least a portion of their functions. For example, a module may include computer code

configured to be executed in one or more processors, and may include hardware logic/electrical circuitry controlled by the computer code. These example devices are provided herein purposes of illustration, and are not intended to be limiting. Embodiments of the present disclosure may be implemented in further types of devices, as would be
5 known to persons skilled in the relevant art(s).

[00177] At least some embodiments of the disclosure have been directed to computer program products comprising such logic (e.g., in the form of software) stored on any computer useable medium. Such software, when executed in one or more data processing devices, causes a device to operate as described herein.

10 [00178] While various embodiments of the present disclosure are described herein, it should be understood that they are presented by way of example only, and not limitation. It will be apparent to persons skilled in the relevant art that various changes in form and detail can be made therein without departing from the spirit and scope of the disclosure. Thus, the breadth and scope of the present disclosure should not be limited by
15 any of the described exemplary embodiments, but should be defined only in accordance with the following claims and their equivalents. The description herein is presented for the purposes of illustration and description. It is not intended to be exhaustive or to limit the disclosure to the precise form disclosed. Many modifications and variations are possible in light of the disclosed teaching. Further, it should be noted that any or all of the
20 alternate implementations discussed herein may be used in any combination desired to form additional hybrid implementations of the disclosure.

CLAIMS

1. A method comprising:

receiving, by a financial management system, a transfer request that identifies a source account and a destination account;

confirming, by the financial management system, that the source account is valid;

confirming, by the financial management system, that the source account has a sufficient balance for the transfer request;

issuing instructions, by the financial management system, to debit the source account and credit a settlement account;

determining, by the financial management system, whether the source account is confirmed as valid and the source account is confirmed as having sufficient balance for the transfer request; and

responsive to determining that the source account is confirmed as valid and the source account is confirmed as having sufficient balance for the transfer request, sending instructions to move funds from the settlement account to the destination account.

2. The method of claim 1, wherein the settlement account is managed by the financial management system.

3. The method of claim 1, further comprising, responsive to determining that the source account is not confirmed as valid or the source account is not confirmed as having sufficient balance for the transfer request, generating a notification that the transfer request failed.

4. The method of claim 3, further comprising communicating the notification to an individual or entity associated with the destination account.
5. The method of claim 1, wherein sending instructions to move funds from the settlement account to the destination account further includes initiating movement of the funds from the settlement account to the destination account.
6. The method of claim 1, further comprising:
 - onboarding, by the financial management system, a new node associated with the financial management system; and
 - assigning a unique identifier to the node.
7. The method of claim 6, wherein the new node is capable of generating a second transfer request that identifies a second source account and a second destination account.
8. The method of claim 6, wherein the new node includes at least one adaptor that integrates the new node with the financial management system.
9. The method of claim 1, wherein the source account is associated with a first ledger at a first financial institution and the destination account is associated with a second ledger at a second financial institution.
10. The method of claim 1, wherein the first ledger and the second ledger are heterogeneous ledgers.

11. The method of claim 1, wherein confirming that the source account is valid is performed in substantially real time.
12. The method of claim 1, wherein confirming that the source account has a sufficient balance for the transfer request is performed in substantially real time.
13. A method comprising:
- receiving, by a financial management system, a transfer request between heterogeneous ledgers;
 - confirming, by the financial management system, that a source account associated with the transfer request is valid;
 - issuing instructions, by the financial management system, to debit the source account and credit a settlement account;
 - determining, by the financial management system, whether the source account is confirmed as valid; and
 - responsive to determining that the source account is confirmed as valid, sending instructions to move funds from the settlement account to a destination account.
14. The method of claim 13, further comprising confirming, by the financial management system, that the source account has a sufficient balance for the transfer request.
15. The method of claim 13, wherein the heterogeneous ledgers include the source account associated with a first ledger at a first financial institution and the destination account associated with a second ledger at a second financial institution.

16. The method of claim 13, wherein the settlement account is managed by the financial management system.

17. The method of claim 13, further comprising, responsive to determining that the source account is not confirmed as valid, generating a notification that the transfer request failed.

18. The method of claim 17, further comprising communicating the notification to an individual or entity associated with the destination account.

19. An apparatus comprising:

a shared ledger configured to store data associated with a plurality of transactions;

and

a financial management system coupled to the shared ledger, wherein the financial management system is configured to:

receive a transfer request that identifies a source account and a destination account;

confirm that the source account is valid;

confirm that the source account has a sufficient balance for the transfer request;

issue instructions to debit the source account and credit a settlement account;

determine whether the source account is confirmed as valid and the source account is confirmed as having sufficient balance for the transfer request; and

responsive to determining that the source account is confirmed as valid and the source account is confirmed as having sufficient balance for the transfer

request, send instructions to move funds from the settlement account to the destination account.

20. The apparatus of claim 19, wherein the settlement account is managed by the financial management system.

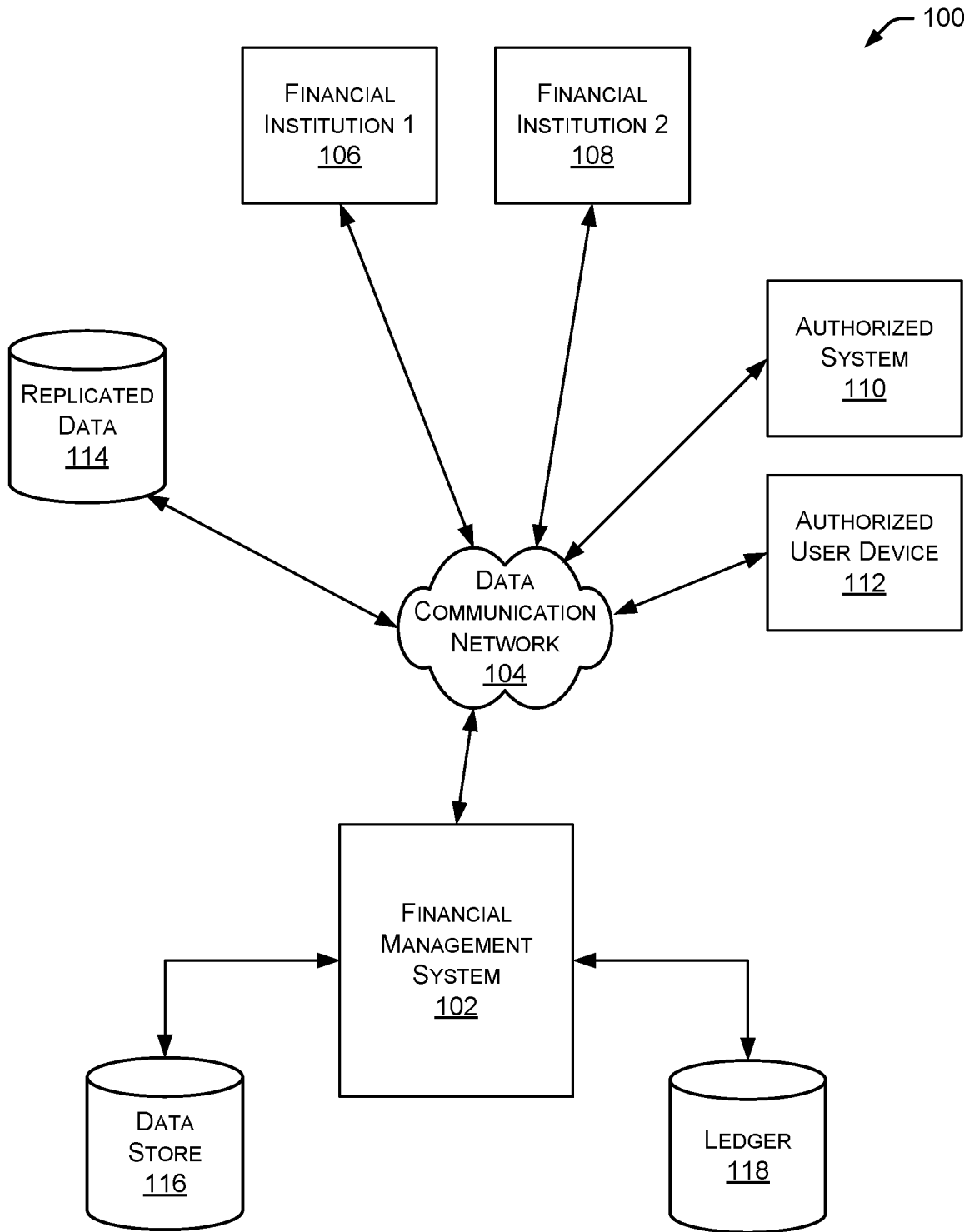

FIG. 1

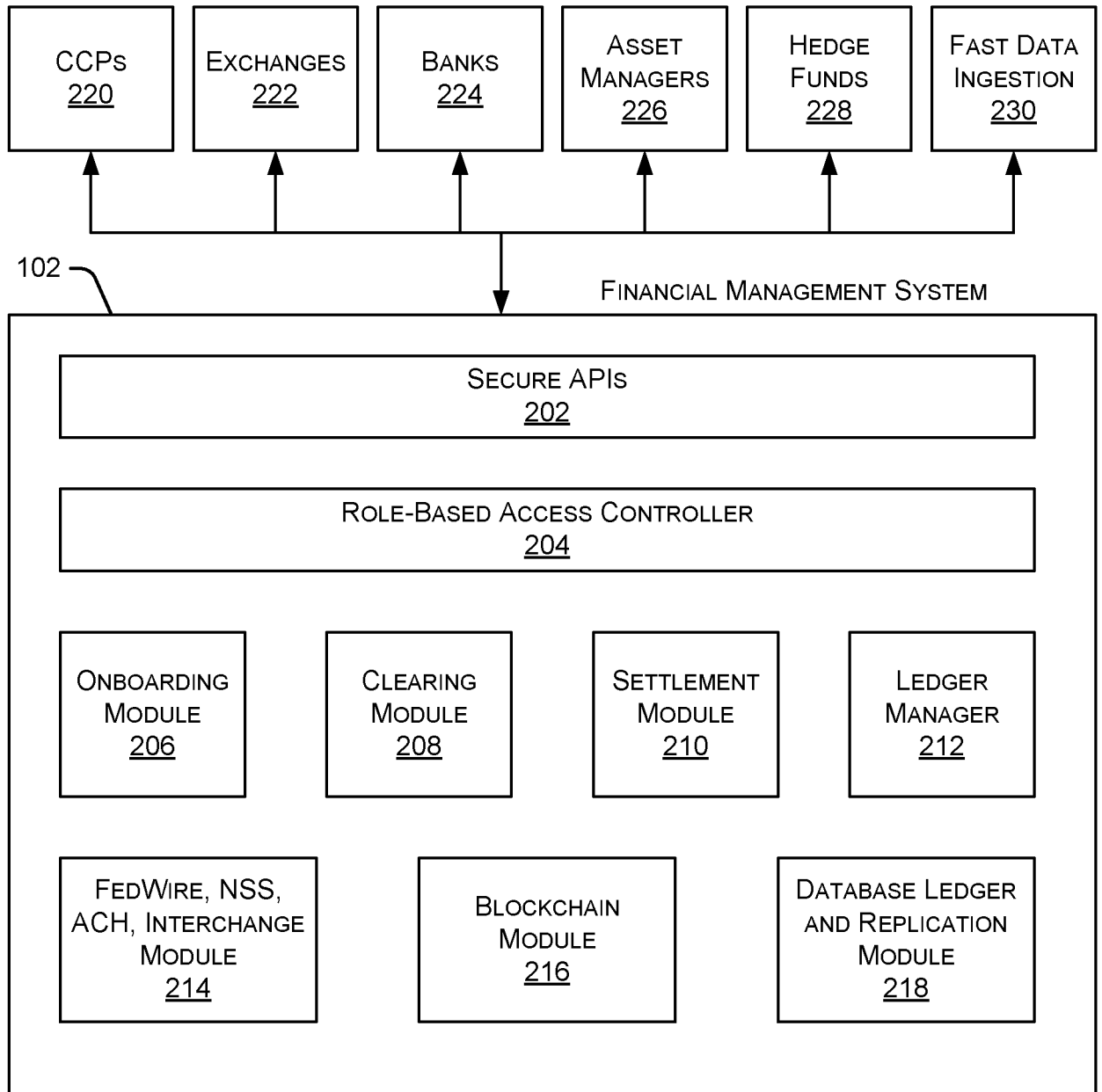

FIG. 2

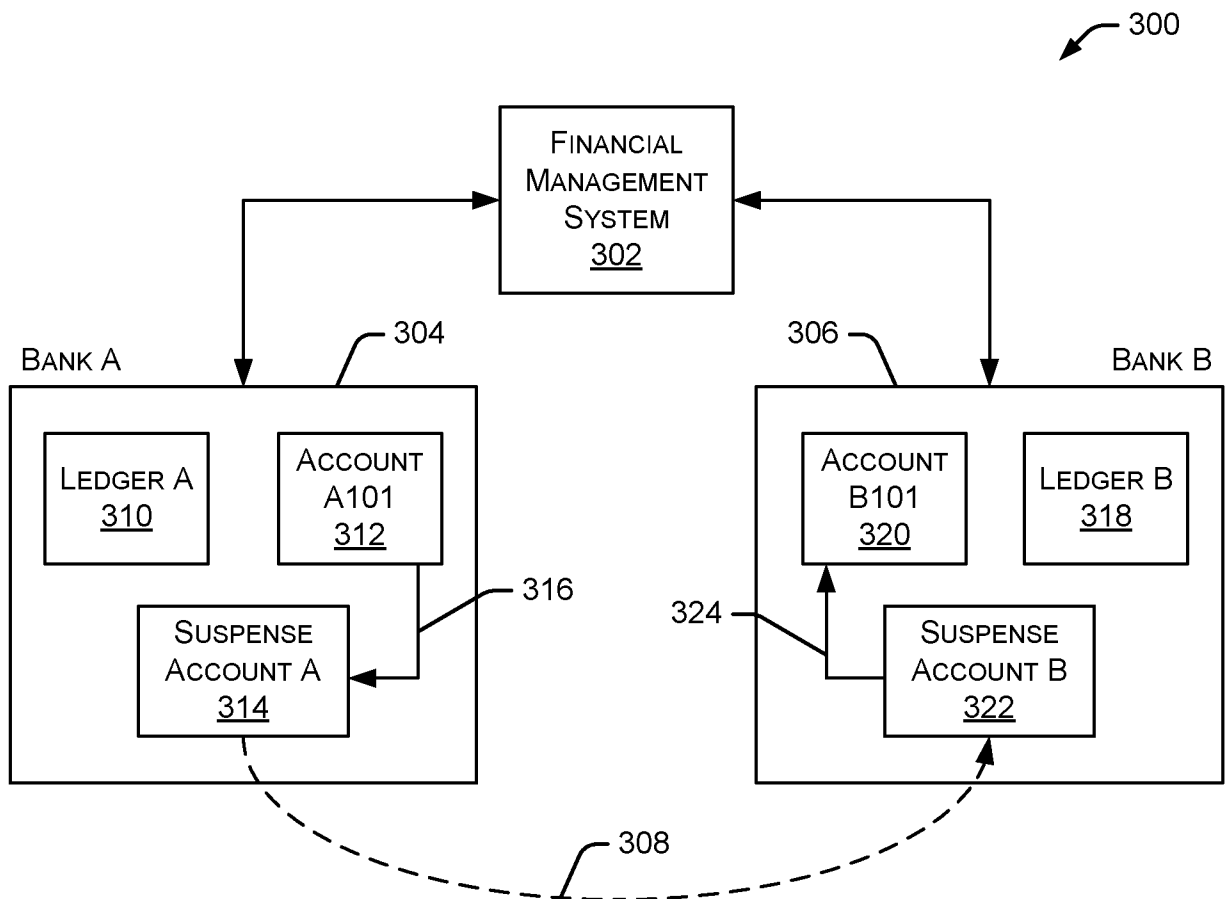

FIG. 3

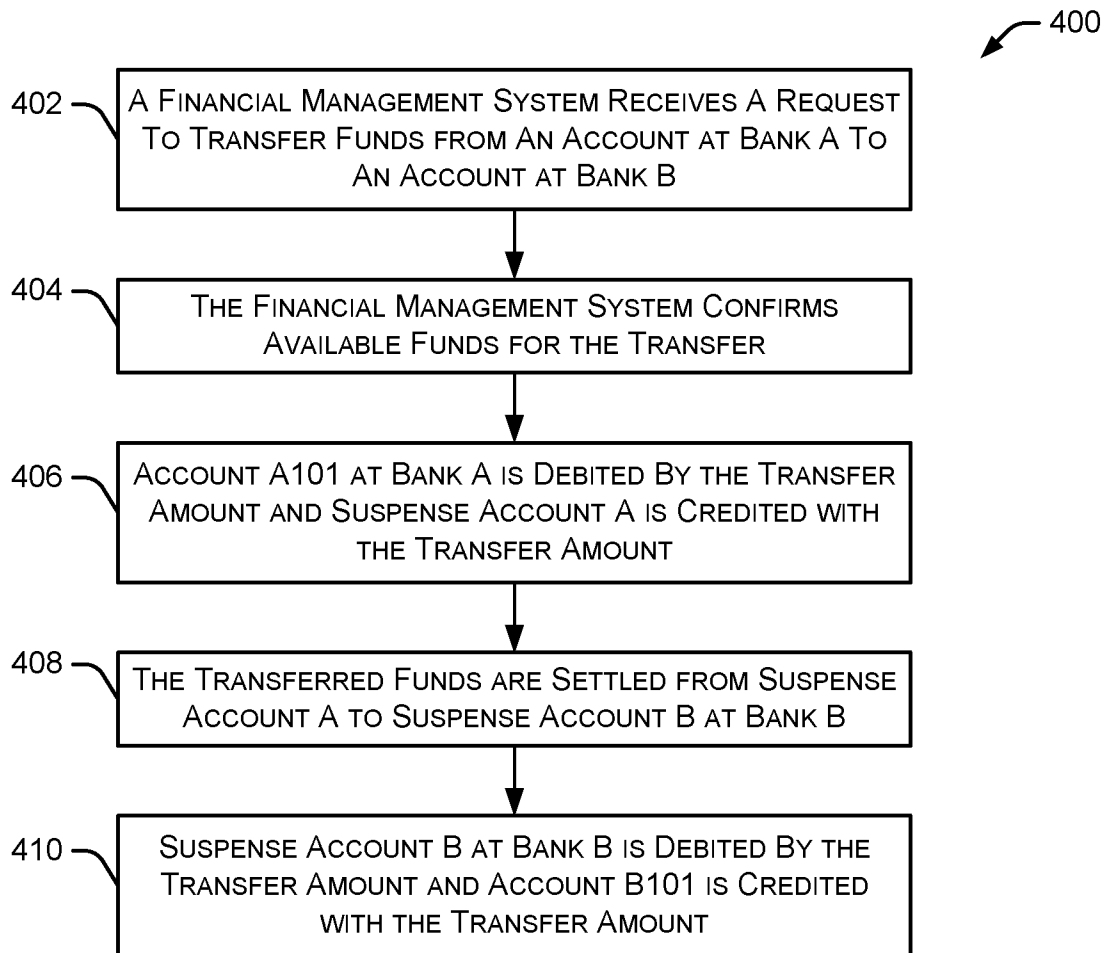

FIG. 4

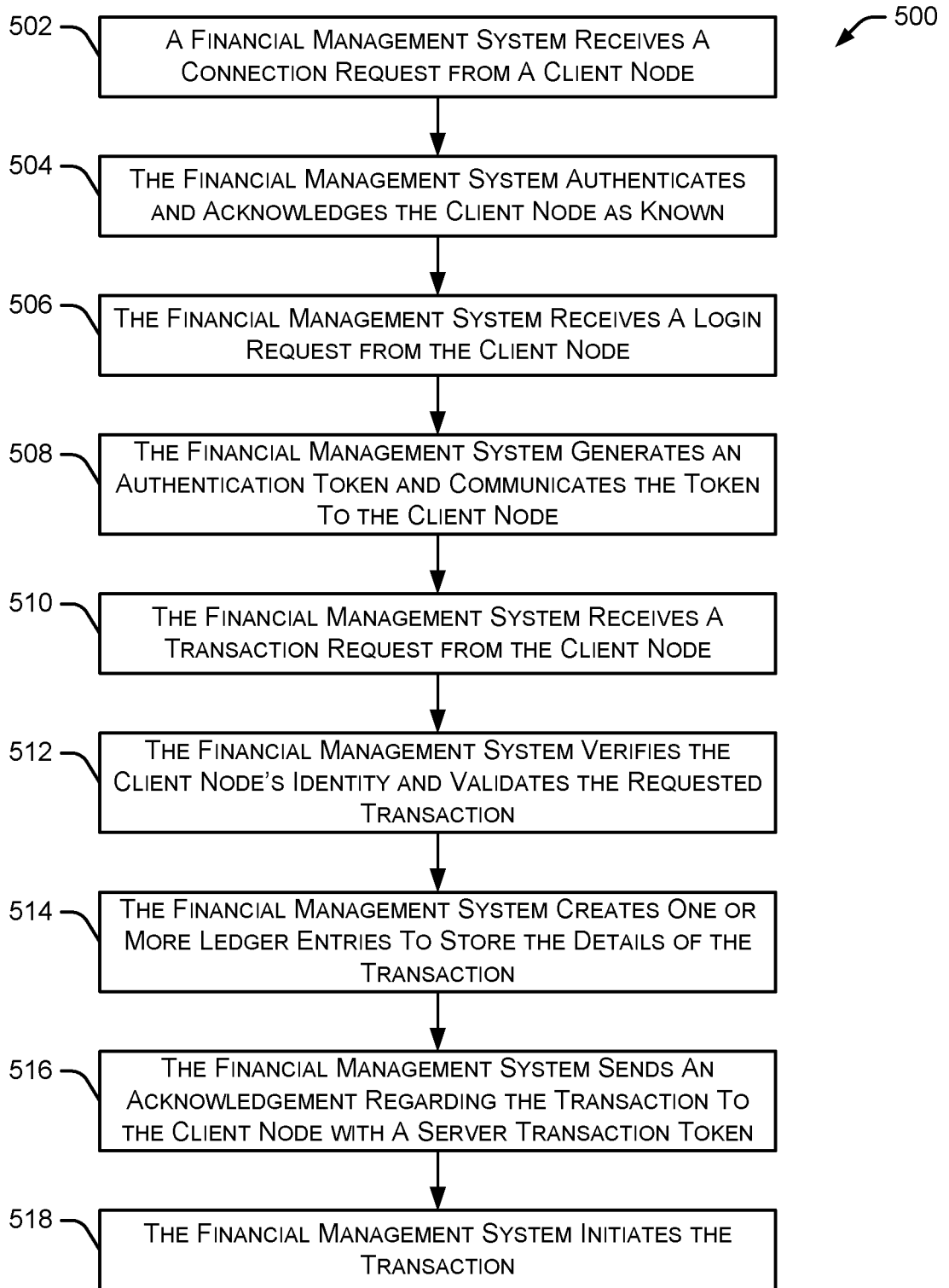

FIG. 5

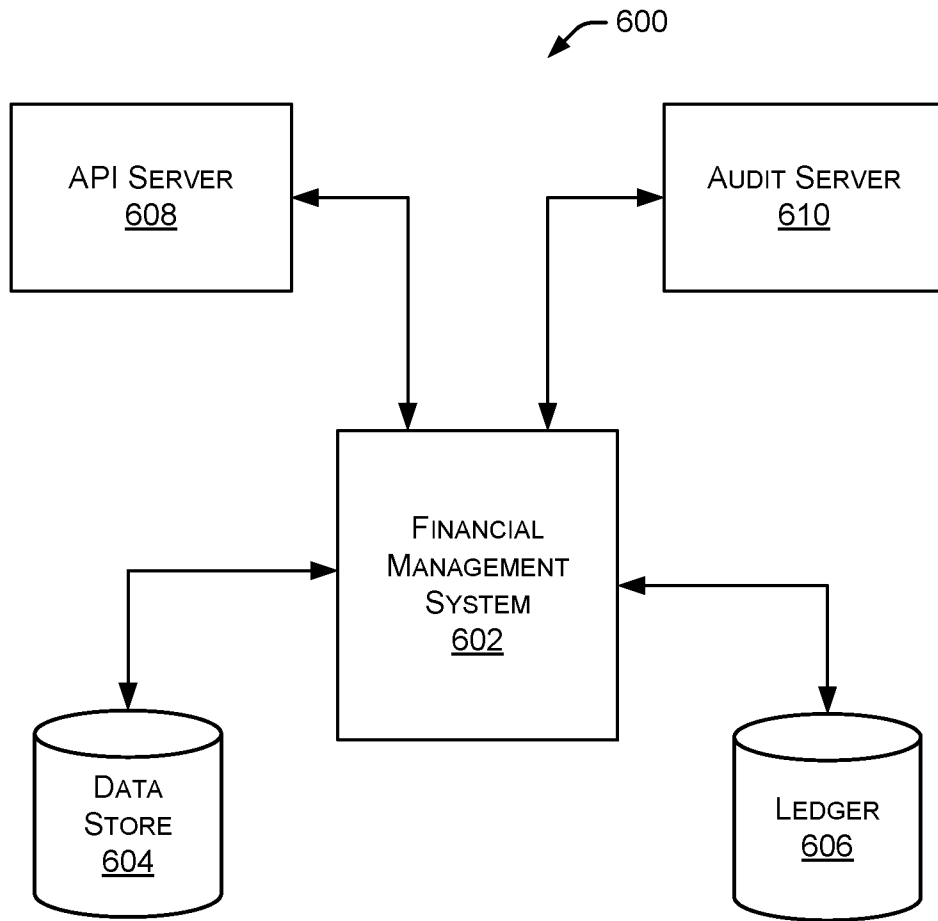

FIG. 6

7/13

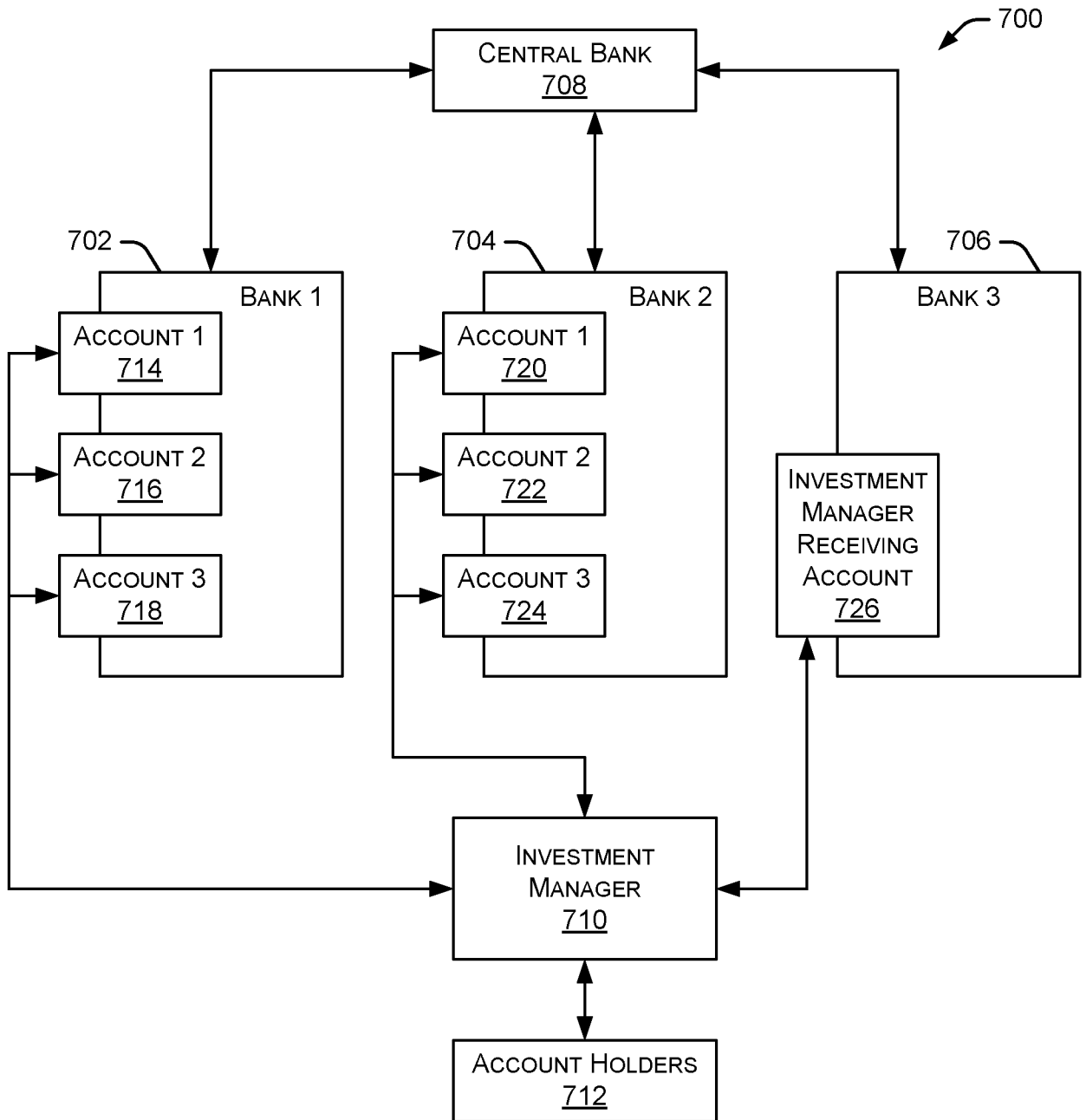

FIG. 7

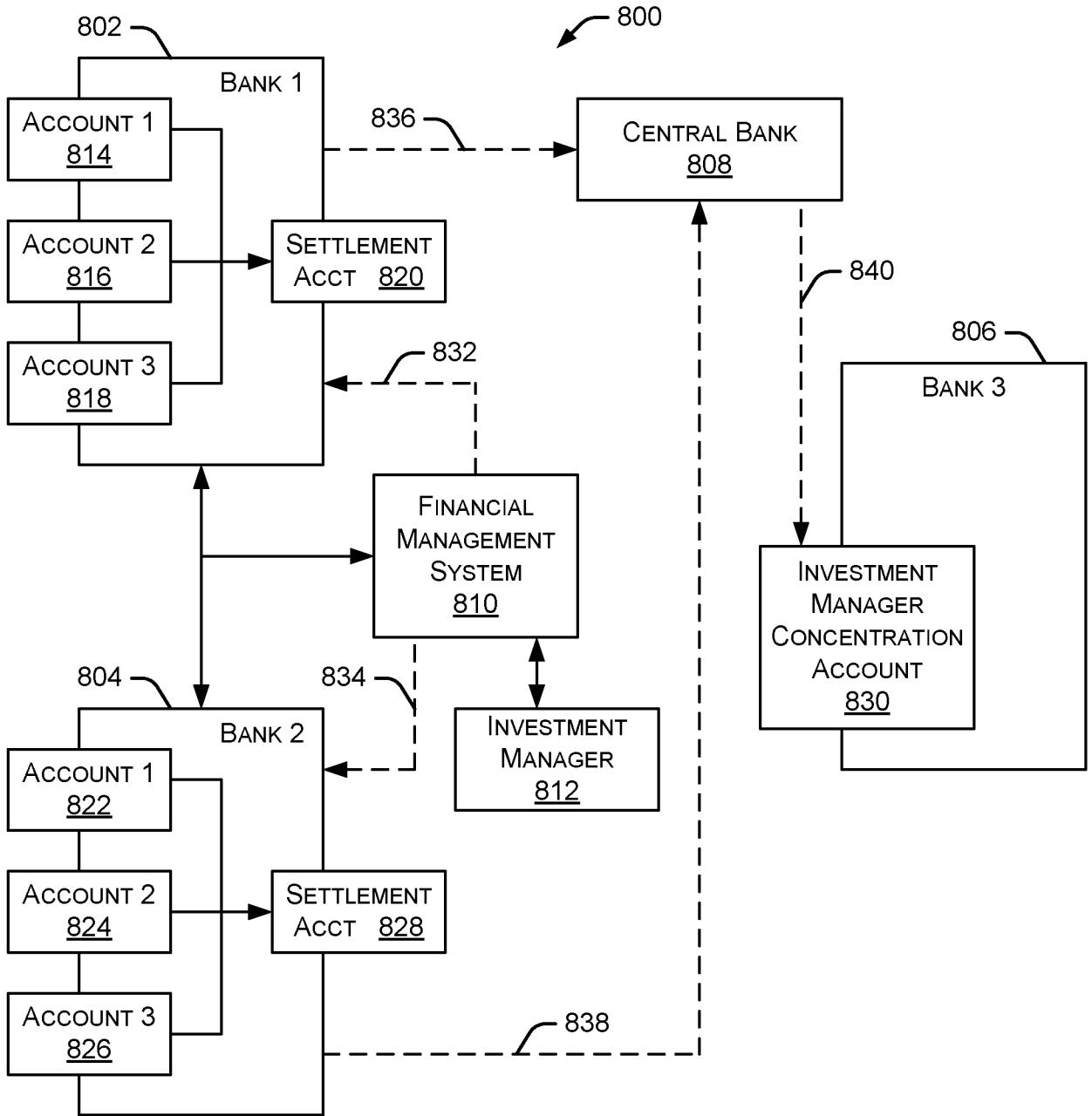

FIG. 8

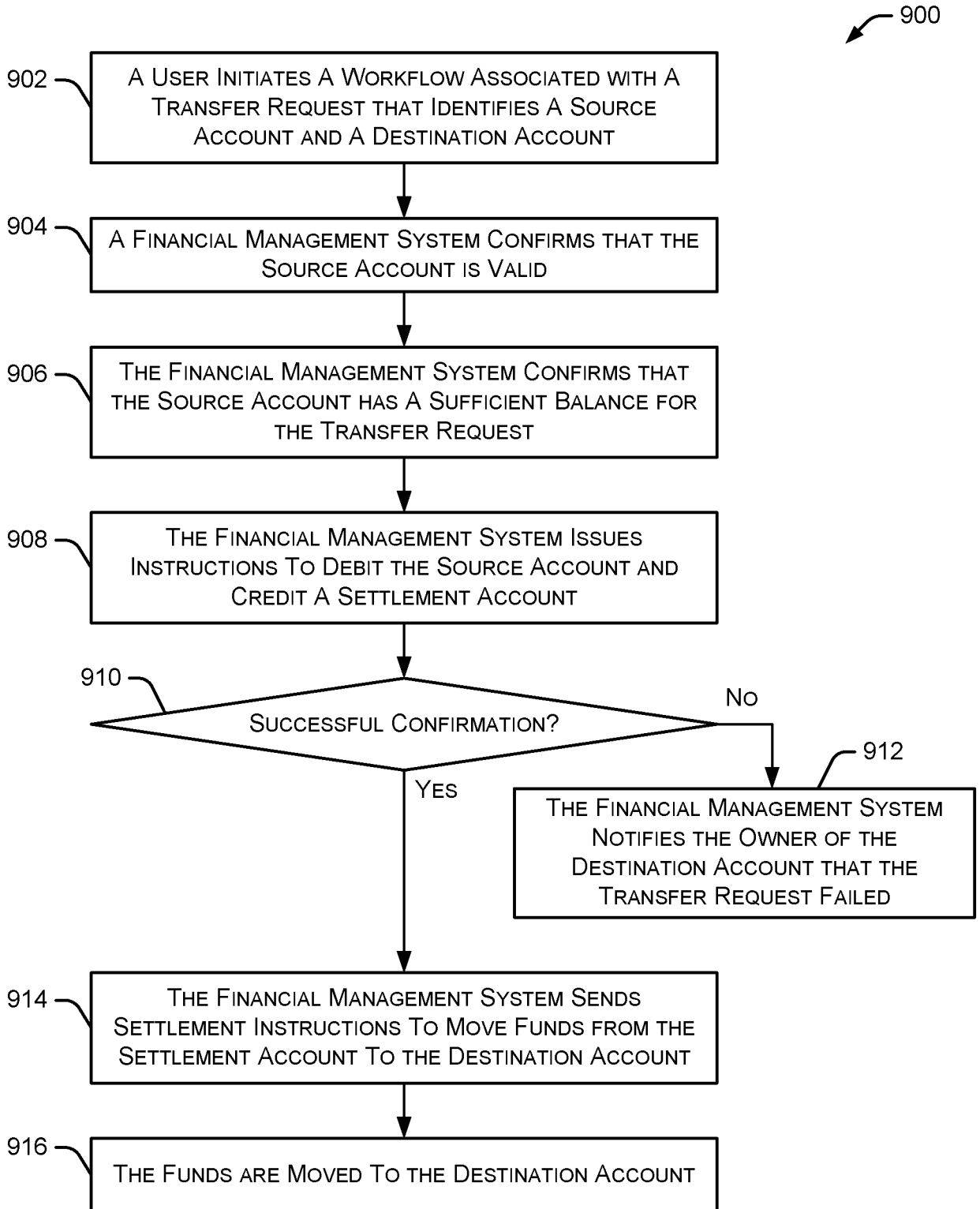

FIG. 9

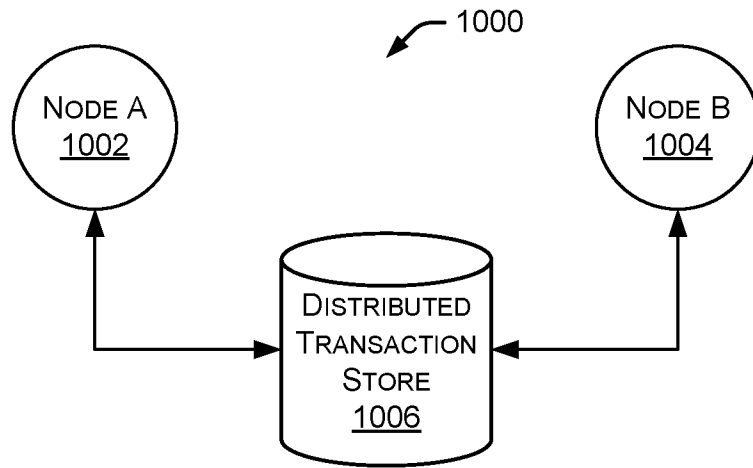

FIG. 10

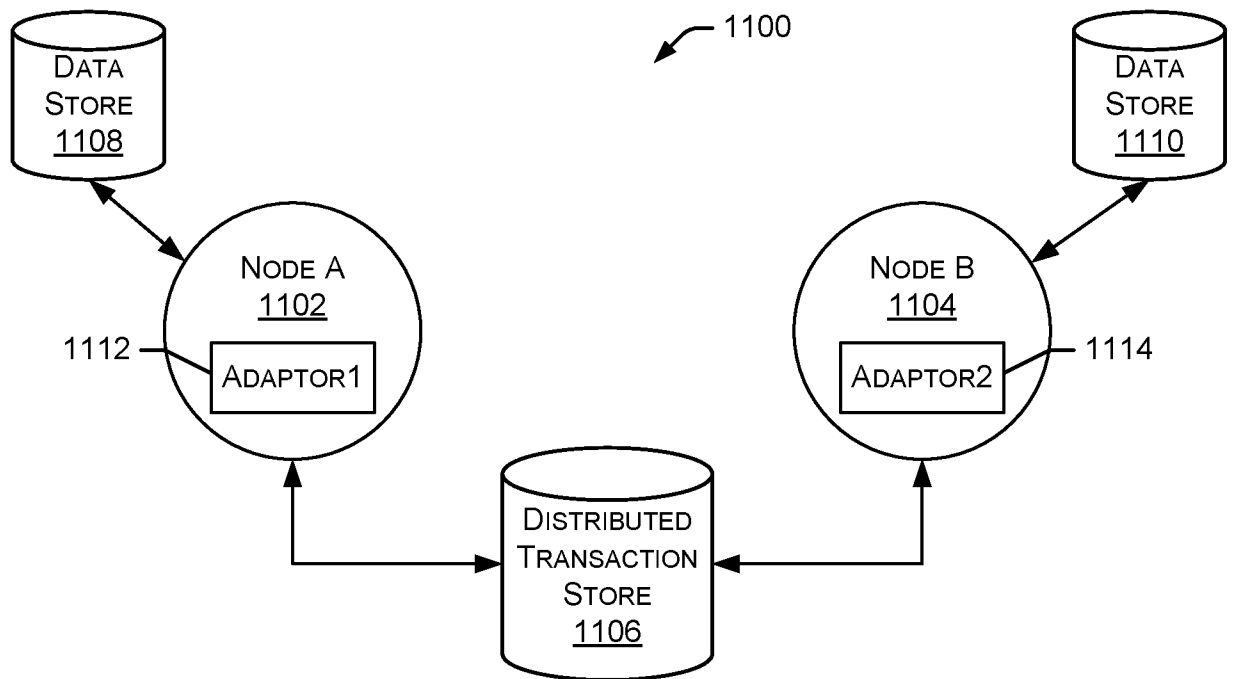

FIG. 11

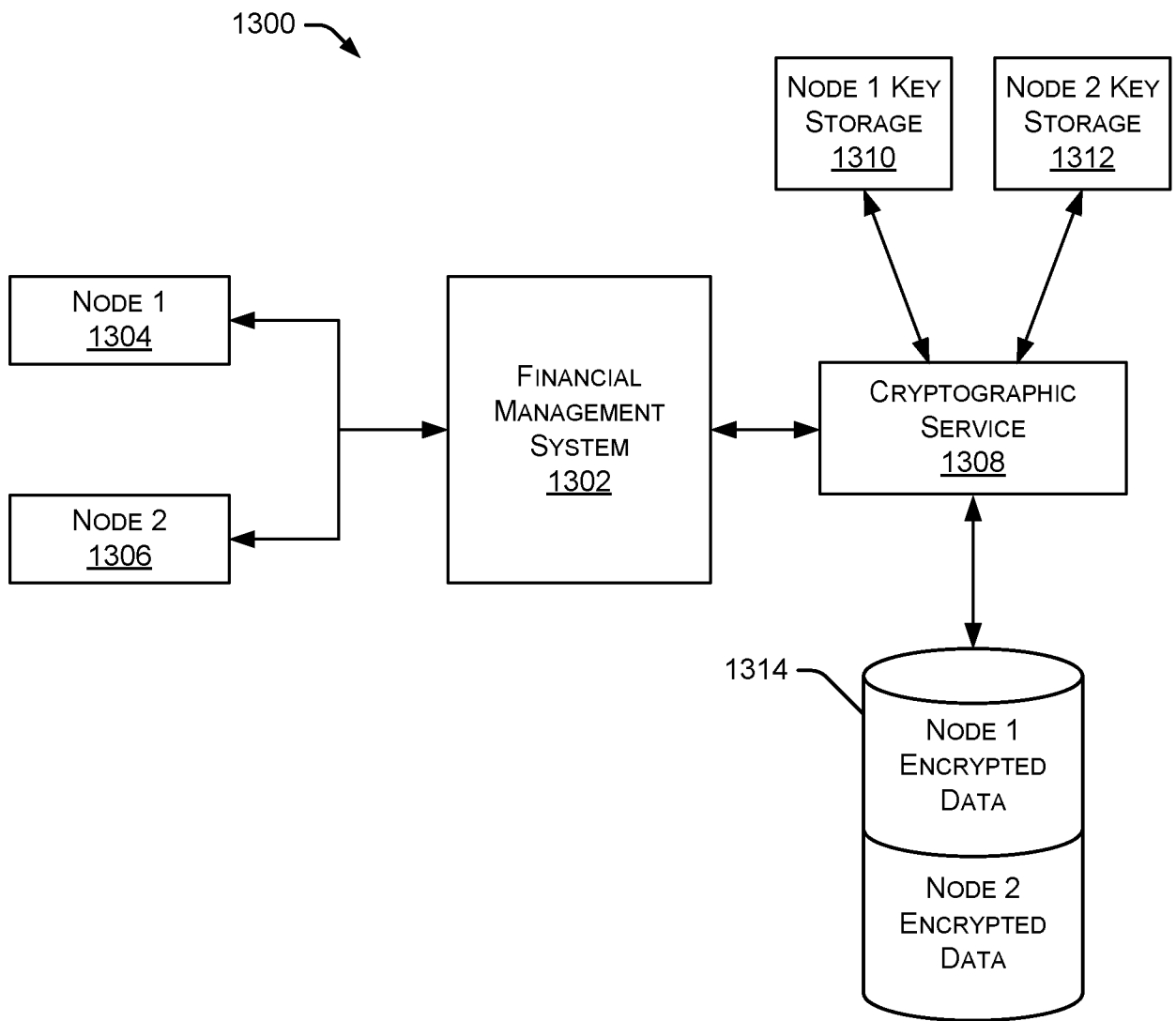

FIG. 13

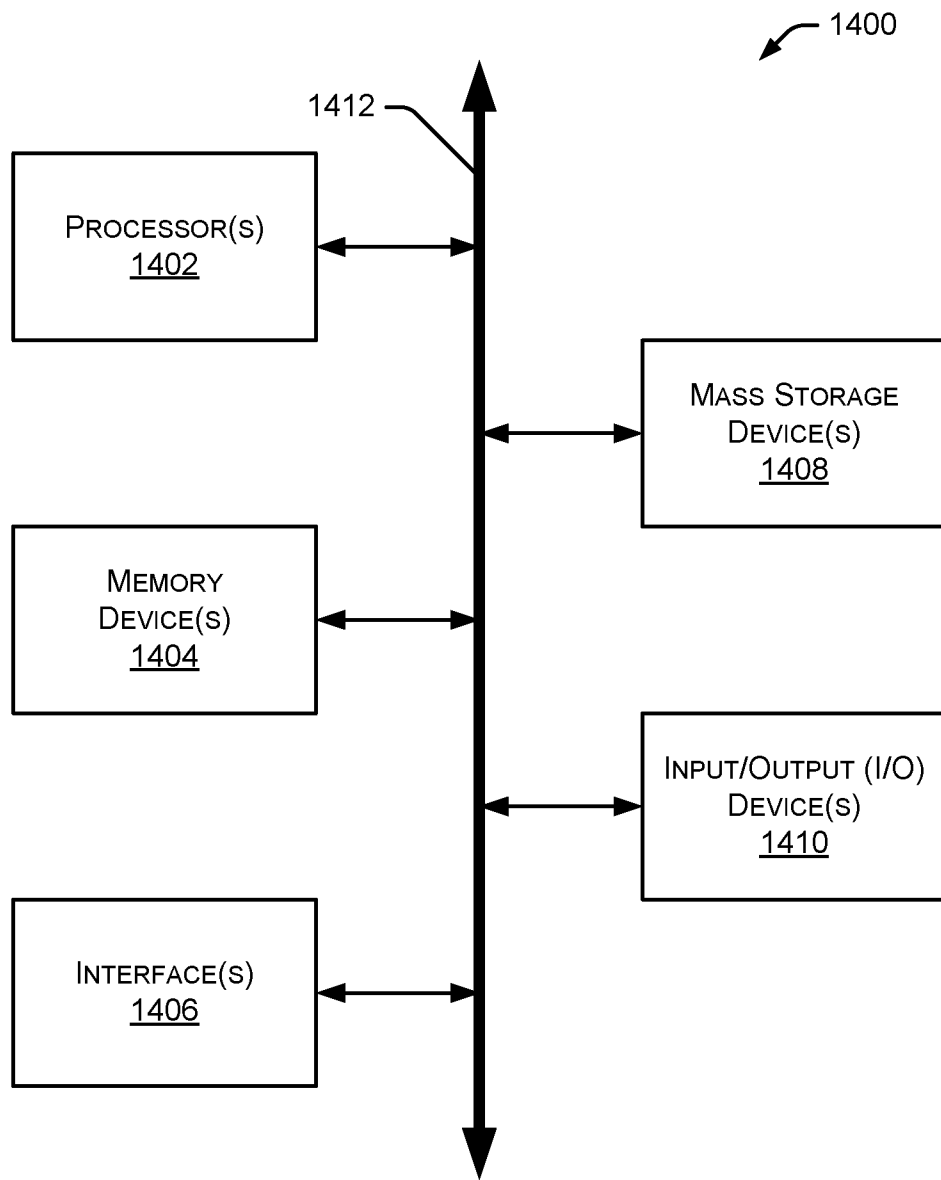

FIG. 14

INTERNATIONAL SEARCH REPORT

International application No.

PCT/US 18/30741

A. CLASSIFICATION OF SUBJECT MATTER

IPC(8) - G06Q 20/00 (2018.01)

CPC - G06Q 20/10, G06Q 20/00, G06Q 20/08, G06Q 20/389, G06Q 20/3829, G06Q 20/401, G06Q 40/06, G06Q 20/027

According to International Patent Classification (IPC) or to both national classification and IPC

B. FIELDS SEARCHED

Minimum documentation searched (classification system followed by classification symbols)

See Search History Document

Documentation searched other than minimum documentation to the extent that such documents are included in the fields searched

See Search History Document

Electronic data base consulted during the international search (name of data base and, where practicable, search terms used)

See Search History Document

C. DOCUMENTS CONSIDERED TO BE RELEVANT

Category*	Citation of document, with indication, where appropriate, of the relevant passages	Relevant to claim No.
Y	US 2014/0114852 A1 (Rajagopal et al.) 24 April 2014 (24.04.2014) entire document especially Abstract, para [0048]-[0050], para [0095]-[0100]	1-20
Y	US 2017/0109735 A1 (FMR LLC) 20 April 2017 (20.04.2017) entire document especially Abstract, para [0150]-[0154], para [0328]-[0330]	1-20
A	US 2011/0106675 A1 (Perlman) 05 May 2011 (05.05.2011) entire document	1-20

 Further documents are listed in the continuation of Box C. See patent family annex.

* Special categories of cited documents:

"A" document defining the general state of the art which is not considered to be of particular relevance

"E" earlier application or patent but published on or after the international filing date

"L" document which may throw doubts on priority claim(s) or which is cited to establish the publication date of another citation or other special reason (as specified)

"O" document referring to an oral disclosure, use, exhibition or other means

"P" document published prior to the international filing date but later than the priority date claimed

"T" later document published after the international filing date or priority date and not in conflict with the application but cited to understand the principle or theory underlying the invention

"X" document of particular relevance; the claimed invention cannot be considered novel or cannot be considered to involve an inventive step when the document is taken alone

"Y" document of particular relevance; the claimed invention cannot be considered to involve an inventive step when the document is combined with one or more other such documents, such combination being obvious to a person skilled in the art

"&" document member of the same patent family

Date of the actual completion of the international search

10 July 2018

Date of mailing of the international search report

09 AUG 2018

Name and mailing address of the ISA/US

Mail Stop PCT, Attn: ISA/US, Commissioner for Patents

P.O. Box 1450, Alexandria, Virginia 22313-1450

Facsimile No. 571-273-8300

Authorized officer:

Lee W. Young

PCT Helpdesk: 571-272-4300

PCT OSP: 571-272-7774