

J. DOORENBOS.

LAMP.

APPLICATION FILED FEB. 25, 1910.

1,002,235.

Patented Sept. 5, 1911.

3 SHEETS-SHEET 1.

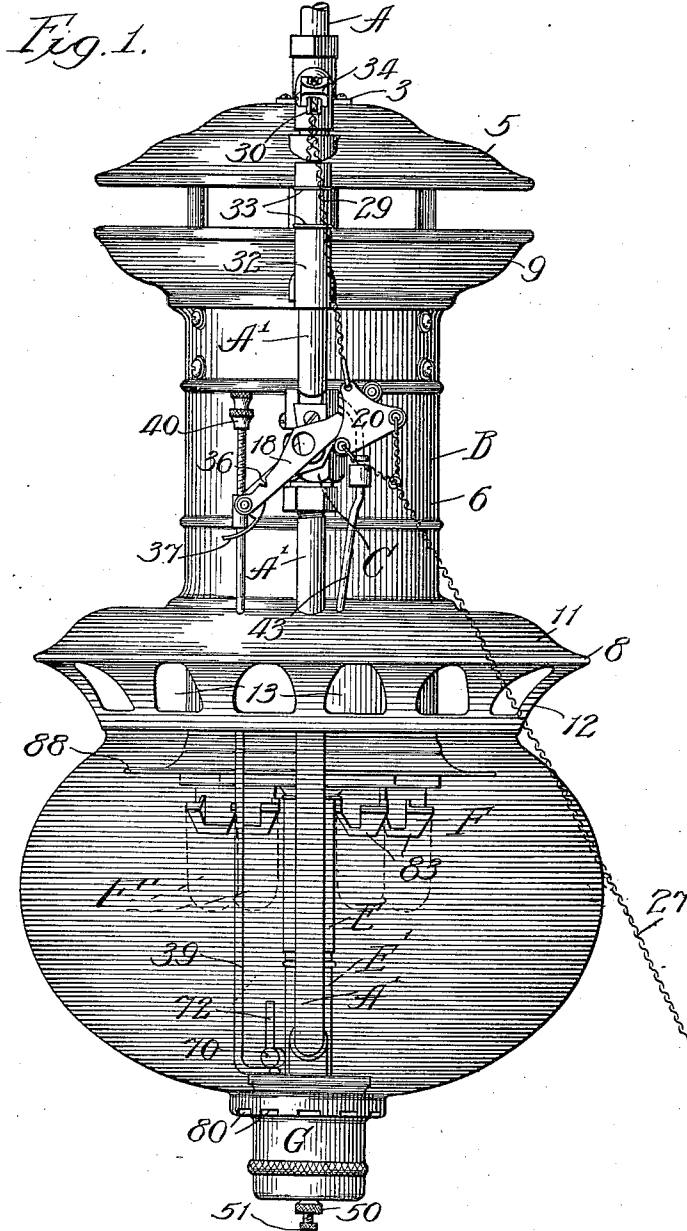

Witnesses:

John Enders
Chas. H. Buell.

Inventor:

John Doorenbos.

By Deane, Smith, Lee, Britton & Wiles,
Attys.

J. DOORENBOS.
LAMP.

APPLICATION FILED FEB. 25, 1910.

1,002,235.

Patented Sept. 5, 1911.

3 SHEETS—SHEET 2.

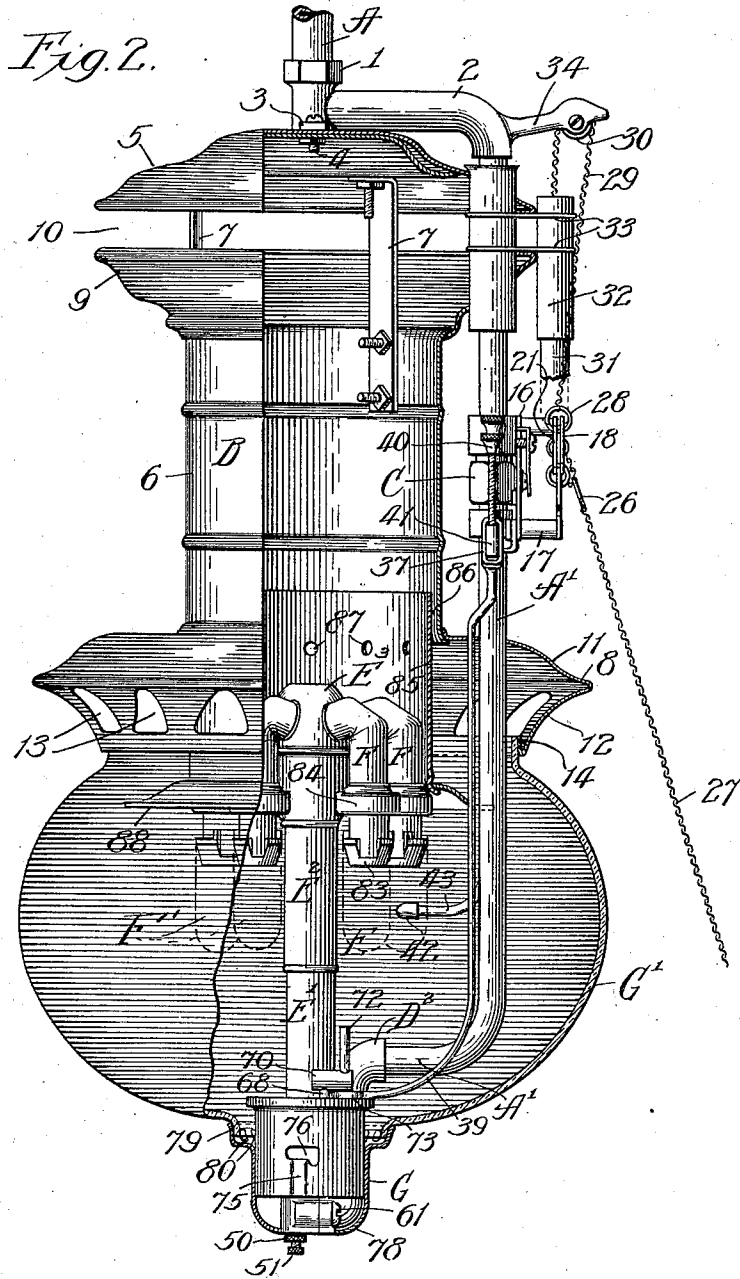

Witnesses:

John Enders
Chas. A. Bull.

Inventor:

John Doorenbos.

By *Depreuxford, Lee, Christon & Miles*
Attys.

J. DOORENBOS.
LAMP.
APPLICATION FILED FEB. 25, 1910.

1,002,235.

Patented Sept. 5, 1911.

3 SHEETS—SHEET 3.

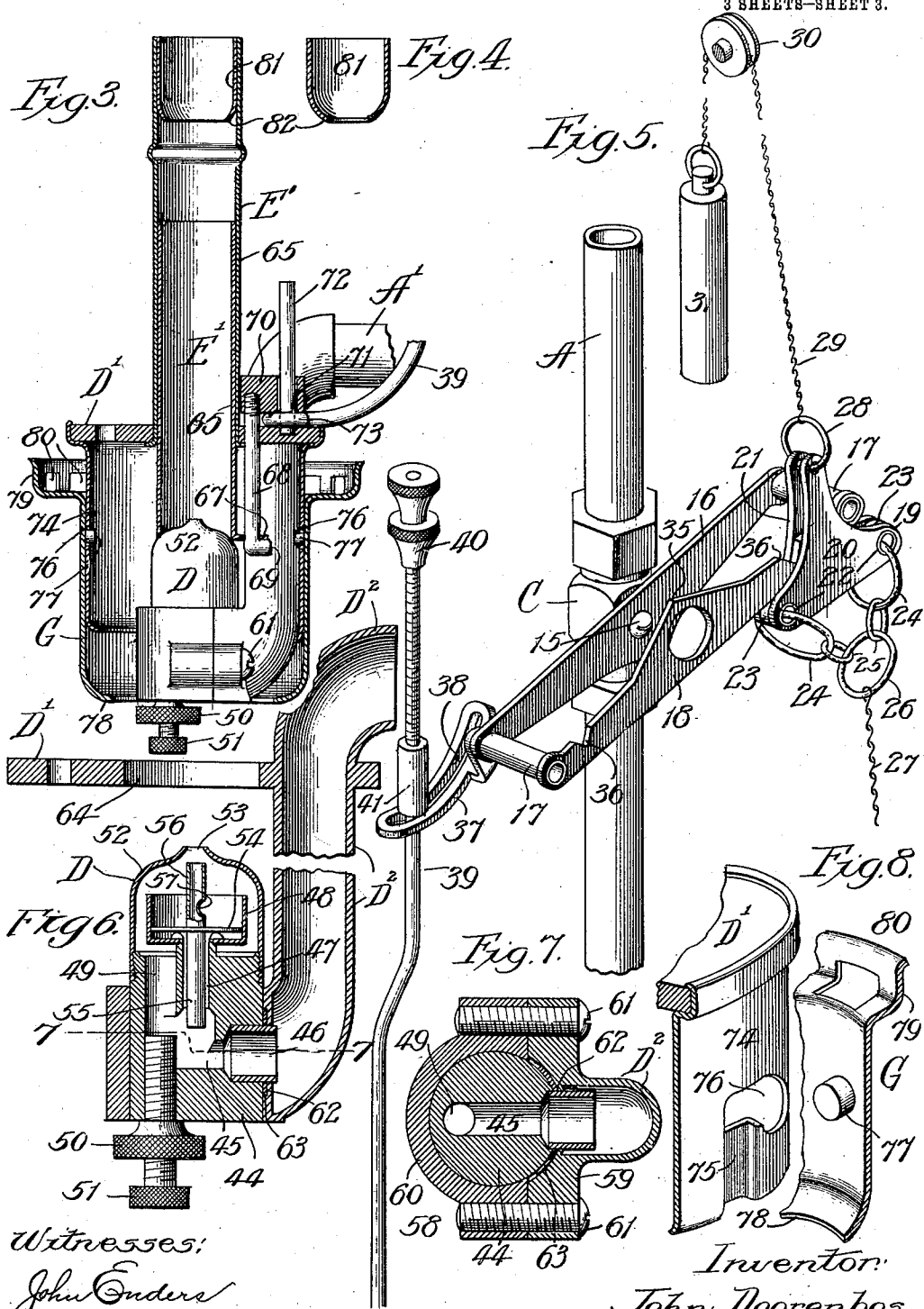

Witnesses:
John Anders
Chas. H. Buell.

Inventor:
John Doorenbos.
By *Dyrenforth, Lee, Christon & Wiles,*
Attys. 44

UNITED STATES PATENT OFFICE.

JOHN DOORENBOS, OF KALAMAZOO, MICHIGAN, ASSIGNOR TO NATIONAL GAS LIGHT COMPANY, OF KALAMAZOO, MICHIGAN, A CORPORATION OF MICHIGAN.

LAMP.

1,002,235.

Specification of Letters Patent.

Patented Sept. 5, 1911.

Application filed February 25, 1910. Serial No. 546,019.

To all whom it may concern:

Be it known that I, JOHN DOORENBOS, a citizen of the United States, residing at Kalamazoo, in the county of Kalamazoo and State of Michigan, have invented a new and useful Improvement in Lamps, of which the following is a specification.

This invention relates particularly to incandescent gas lamps employing a cluster, or group, of burners, and mantles therefor, although certain features of the invention are applicable to incandescent gas lamps generally.

The primary object of the invention is to provide a lamp of the character indicated of improved general construction and of improved operation.

It may be preliminarily stated that the improved lamp herein described comprises improved means for regulating the supply of air and gas to the lamp, having for an object the prevention of explosions within the lamp at the instants of lighting and of turning out the light, and having for a further object the creation of the best conditions of combustion; improved means for regulating the passage of gas and air through the mixer-tube of the lamp; improved means for actuating the manually-controlled gas-valve with which the admission-pipe of the lamp is equipped; an improved valve for regulating the passage of the gas to the mixer-tube, whereby the lamp will automatically adjust itself to varying conditions of gas-pressure; and improved details of construction which will be more particularly described hereinafter and included in the appended claims.

The invention is illustrated in its preferred embodiment in the accompanying drawings, in which—

Figure 1 represents an elevational view of a lamp constructed in accordance with my improvements; Fig. 2, a view at right angles to the view shown in Fig. 1, partly in section and partly in elevation; Fig. 3, a broken sectional view on an enlarged scale showing a gas-pipe section, an automatic valve-device and the mixer-tube; Fig. 4, a sectional view showing an interchangeable choking-device to be employed in the mixer-tube in lieu of the one shown therein in Fig. 3; Fig. 5, a broken perspective view of the gas-pipe of the lamp, the manually-controlled valve connected therewith, and the valve-actuating

mechanism; Fig. 6, a broken sectional view on an enlarged scale of the parts shown in the lower portion of Fig. 3; Fig. 7, a horizontal sectional view taken, as indicated, at line 7 of Fig. 6; and Fig. 8, a broken perspective view of a globe-support and a carrying-member therefor, the view showing the inner surface of the globe-support and the outer surface of its carrying-member.

In the construction shown, A represents a gas-pipe from which the lamp is suspended and with which communicates a branch-pipe A¹; B, a chimney suspended from the pipe A; C, a valve controlling the passage of gas through the branch-pipe A¹; D, an automatic valve regulating the passage of gas from the branch-pipe A¹ to the mixer-tube; D¹, a disk supported by a pipe D² connected with the lower end of the branch-pipe A¹, said pipe D² serving also to support the automatic valve D; E, a mixer-tube supported by the disk D¹ and comprising a lower fixed section E¹ and an upper removable section E² surmounted by a mixer-chamber E³; F, a plurality of burner-tubes connected with the mixer-chamber E² and having down-turned orifices; F¹, mantles carried by the burner-tubes; G, a globe-support supported through the medium of the disk D¹; and G¹, a globe supported at its lower portion by the globe-support G and having its upper end housed by the lower portion of the chimney B.

The lower end of the lamp-supporting pipe A is connected with a nipple 1 formed integrally with the pipe-section 2 which forms a portion of the branch-pipe A¹. The nipple 1 has lugs 3 formed integrally therewith, through which pass screw-bolts 4 attached to the top-member of the chimney B.

The chimney B comprises a top-member 5; a cylinder 6 suspended therefrom through the medium of arms 7; and a hood 8 connected with the lower end of the cylinder 6. The upper end of the cylinder 6 has an outwardly-flaring portion 9 which is separated from the upwardly-dished top-member 5 by a space 10 through which the products of combustion may pass from the lamp. The hood 8 has a downwardly and outwardly flaring portion 11 extending from the base of the cylinder 6, and an inwardly converging portion 12 equipped with air-admission ports 13. The portion 12 has an internal up-turned flange 14 at its lower end within which the upper portion of the globe fits.

The manually-controlled valve C is of the usual form and has a laterally-projecting stem 15 equipped with an actuating-lever 16. The lever 16 extends on both sides of the stem 15 and has its ends equipped with laterally-projecting posts 17 which support a track or guide member 18 with which is connected an automatically-shiftable slide or actuating-member 19. The slide 19 comprises two triangular-shaped plates 20 and 21 which embrace the track or guide 18 and have their lower corners connected by tubular rivets 22 which support rollers 23 adapted to engage the lower edge of the member 18. Through the tubular rivets 22 extend rings 24 which are connected by links 25 with a ring 26 from which is suspended an operating chain 27. The apex-portions of the plates 20 and 21 are provided with perforations which receive a ring 28 with which connects a chain 29 which extends over a wheel 30 and is attached to a counterweight 31 adapted to slide in a tubular guide 32 carried by brackets 33. The wheel 30 is supported on a bracket-arm 34 formed integrally with the pipe-section 2. The lower edge of the track or guide 18 is straight, and the upper edge is formed with a central apex 35. From the apex 35 the upper edge surfaces slope to the ends of the member 18, and V-shaped notches 36 are cut in the upper edge near the ends of said member. In either the closed or the wide-open position of the valve C, the lever 16 and guide or track 18 stand in an inclined position, and the slide 19 is normally held in a position at the upper end of the track by the counterweight 31. When it is desired to operate the valve, the chain 27 is pulled, thereby drawing the slide downwardly until the ring 28 (that portion which passes between the plates 20 and 21) engages the adjacent notch 36, whereupon the continued downward pull upon the chain will actuate the valve. Upon the release of the chain 27, the counterweight will operate to shift the slide 19 to the other end of the track 18, which is now the elevated portion of the track.

One end of the lever 16 is equipped with a bracket 37 in the form of a curved plate or segment which is provided with a slot 38. Through the slot 38 extends a vertically-disposed rod 39 whose upper end is threaded and equipped with a nut 40 which forms an adjustable stop or shoulder. The rod 39 is equipped above the curved bracket 37 with a sleeve 41 adapted to move freely on the rod until it engages the nut 40, as will be readily understood from Fig. 5. The rod 39 serves to operate an air-valve or shutter which controls the admission of air to the mixer-tube of the Bunsen burner. As will be understood from Fig. 5, there is lost-motion connection between the rod 39 and the bracket 37, and this lost-motion is sufficient

to permit the valve C to be opened somewhat to admit gas to the lamp before the air-valve or shutter is actuated.

The lamp is equipped with a pilot-burner 42 whose supply-tube 43 communicates with the pipe A¹ above the valve C, so that there is always a supply of gas to the pilot-burner, enabling a flame to be maintained thereat perpetually. When the valve C is opened somewhat during the actuation of the lever 16 from the position shown in Fig. 5, the gas will be admitted to the Bunsen burner and ignited at the mantles of the lamp before the air-valve or shutter of the Bunsen burner is moved to admit air to the mixer-tube, so that ignition of the gas occurs before an explosive mixture of air and gas accumulates in the lamp. It will be readily understood that this feature preserves the mantles from the injury which has heretofore resulted from unavoidable explosions. When the valve C is operated to shut off the gas-supply, the air-valve or shutter of the Bunsen burner will drop by gravity and close the air-admission orifice of the Bunsen burner before the gas-supply is wholly shut off, as will be presently explained in detail.

The automatic valve D which serves to regulate the admission of gas to the mixer-tube E of the Bunsen burner preferably comprises a cylindrical plug-form member 44 containing a passage 45 with which connects a laterally-projecting tubular nipple 46; a central passage 47 which communicates with the passage 45 and leads to a cylinder 48 which surmounts the member 44; a by-pass 49 communicating with the passage 45 and having an orifice at the upper end of the member 44, said by-pass being controlled by a screw 50 connected with the lower portion of the member 44 and equipped beneath said member with a knurled head 51; a shell or cap member 52 having screw-connection with the upper portion of the member 44 and housing the cylinder 48, the upper end of the cylinder 48 being open, and said cap-member 52 being provided with a central gas-orifice 53; and a piston or disk 54 within the cylinder 48 and equipped with a guide-stem 55 which extends downwardly loosely through the central passage 47; said disk 54 carrying an upwardly extending tubular valve 56 into which gas is admitted through a lateral passage 57, the upper end of the member 56 coacting with the gas-orifice 53 and being open, as shown. The disk D¹ is cast integrally with the pipe-section D² between the ends thereof. The upper end of the pipe-section D² is curved outwardly and connected with the incurved lower end of the pipe A¹. The lower end of the pipe-section D² carries a separable bracket-ring 58, the one section 59 of which is formed integrally with the lower end of the pipe-section, and the other portion 60 is secured

to the portion 59 by screws 61. The ring 58 receives the member 44 of the automatic valve, and the section 59 has a wall 62 provided with a perforation into which the lateral nipple 46 fits accurately. An asbestos washer 63 may be provided between the parts, as shown in Figs. 6 and 7.

The disk D^1 is equipped, above the automatic valve D, with a central perforation 64 which receives the lower end of the mixer-tube section E^1 .

Within the lower portion of the tube E is a vertically-movable tube 85 whose lower end rests normally on the cap-piece 52 of the automatic valve D, as shown in Fig. 3. The cap 52 is separated from the disk D^1 and the lower end of the tube E^1 by a space 86 which constitutes an air-admission port through which air is admitted to the mixer-tube of the Bunsen burner. When the tube 65 is in its lowermost position, the air-supply to the mixer-tube is cut off. The lower end of the tube 65 has a laterally-projecting lug 85 provided with a perforation through which extends a short rod 68 having a laterally-turned lower end 69. The upper end of the rod 68 has threaded connection with a member 70 which is provided with a perforation 71 which receives a guide-stud 72 carried by the disk D^1 . The member 70 rests upon an eye 73 which encircles the stud 72 and is formed integrally with the inturned lower end of the rod 39, whose upper end, it will be recalled, has lost-motion connection with the bracket 37 carried by the lever 16 of the manually-controlled valve C. When the rod 39 is raised, during the operation of throwing the valve C to the wide-open position, the member 70 is raised on the guide-stud 72, thereby raising the tubular-valve or air-shutter 65 and admitting air to the mixer-tube.

The disk D^1 has connected with it the upper portion of a tubular-carrying member 74 which houses the lower portion of the pipe-section D^2 and attendant parts. The member 74 has the metal of the lower portion thereof struck in to form vertical external grooves 75, as will be understood from Fig. 8, and lateral slots 76 are provided at the upper portions of the grooves 75. The tubular globe-support G is provided internally with studs 77 adapted to move in the grooves 75 and lateral slots 76, whereby a bayonet-joint connection is provided between the carrying-member 74 and the globe-support G.

The lower end of the tubular support G is curved inwardly, as indicated at 78, to closely encircle the lower portion of the automatic valve, the regulating-screw 50, however, depending through the opening at the lower end of the member G. The upper end of the member G flares outwardly, as indicated at 79, thereby affording a support for the lower

end of the globe. The portion 79 is provided with air-inlets 80.

The upper end of the mixer-tube section E^1 is provided with an internally-located choking-ring 81, or thimble comprising a short sleeve having an incurved lower end 82. In practice, a number of interchangeable members 81 are provided of uniform diameter, but having different-sized openings at their lower ends, and adapted to regulate the volume of the mixture passing through the mixer-tube. In Fig. 4, I have shown another choking-device of the same construction as that shown in Fig. 3, except that it has a smaller opening at its lower end.

The section E^2 of the mixer-tube E has telescopic connection at its lower end with the upper end of the fixed section E^1 and is removable therefrom. As has been indicated, the tube section E^2 is surmounted by the mixer chamber E^3 from which the burner tubes F branch and depend. The burner tubes F are equipped with burner tips 83 having at their base portions flanges 84. Resting removably on the flanges 84 of the burner tips, which it will be understood are arranged in a circle about the mixer-tube, is a sheet metal cylinder 85, whose upper end extends somewhat into the cylinder 6 constituting the body of the chamber. The cylinder 85 is of somewhat less diameter than the cylinder 6, thereby affording the annular space 86 between the upper end of the member 85 and the lower end of the member 6. The cylinder 85 is provided near its upper end with perforations 87. The lower end of the cylinder 85 is equipped with a bell-shaped disk or shield 88.

From the foregoing detailed description the operation will be readily understood. Gas is supplied to the lamp through the pipe A, and a small flame is maintained perpetually at the pilot-burner 42. When it is desired to light the main burners, it is necessary only to pull the chain 27, thereby pressing the right-hand portion of the lever 16 shown in Fig. 5 and opening the annular controlled admission valve C. In this operation, the valve C is opened somewhat before the segmental bracket-arm 37 elevates the sleeve 41 sufficiently to engage the nut 40 on the rod 39. The main burners are lighted, therefore, before air is introduced in the mixer-tube of the Bunsen burner. During the final portion of the operation of opening the valve C, the rod 39 is elevated, thereby elevating the member 70 shown in Fig. 3 and, through the medium thereof, opening the air-valve or shutter 65 of the Bunsen burner. After the valve C has been thrown to the wide open position and the operator releases his hold upon the chain 27, the weight 31 operates automatically to elevate the slide 19 and shift it to the other end

of the track 18, where it is in position to actuate the valve C when it is desired to turn off the light. After the chain 27 has been again pulled to shut off the light, the slide 19 automatically shifts again to the position shown in Fig. 5 in readiness for another operation of turning on the light.

The gas which supplies the main burners passes through the automatic regulator D. A certain amount of the gas passes through the central passage 47 and elevates the piston 54, more or less, depending upon the gas pressure. As the piston 54 is raised, the upper end of the tubular stem 56 approaches the orifice 53 and contracts the opening. When the upper end of the tubular valve 56 engages the inner wall of the apex of the cap 52 adjacent to the orifice 53, the gas is then compelled to pass practically wholly through the perforation 57 and tubular valve 56. It will thus be seen that the area of the orifice through which the gas is admitted to the mixer-tube of the Bunsen burner is a variable one, decreasing with an increase of gas pressure, but at one limit of movement of the piston 54 the outward orifice becomes fixed in area. Practical demonstrations have shown that an automatic valve of this character will accommodate the lamp to such a wide range of variation of pressure as will adapt the lamp for use in practically all of the municipalities throughout the United States; and it may be here remarked that the pressures employed in different municipalities vary through a wide range, and that the pressure employed in any one of many of the municipalities varies from hour to hour through quite a wide range.

The relation of the various passages of the lamp is such as to avoid violent currents at any given position beneath the cylinder 6 of the chimney, and the delicate mantles are protected not only from violent drafts but from explosions at the instants of turning on and turning off the light. Some of the air which enters through the passages 13 of the hood or bell of the chimney passes downwardly to the zone of combustion at the mantles and some of it passes upwardly through the annular passage 86 encircling the upper portion of the internal flue 85. Air may reach the interior of the cylindrical member 74 surrounding the annular admission port 66 of the mixer-tube of the Bunsen burner through the lower end of the globe support G; and the disk D¹ may be provided with perforations so that some of the air entering through the passages 13 at the base of the chimney may likewise reach the mixer-tube.

The foregoing detailed description has been given for clearness of understanding only, and no undue limitation should be understood therefrom. As an illustration, it

may be stated that the counterweight device which serves to automatically elevate and shift the slide 19 after the valve C has been actuated need not necessarily be of the form illustrated, as any suitable counterweight device, for instance one employing a spring in lieu of the weight, will serve the purpose.

What I regard as new, and desire to secure by Letters Patent, is—

1. In a lamp, the combination of a Bunsen burner equipped with a mantle, a conduit through which gas is admitted to the mixer-chamber of the Bunsen burner, a valve controlling the admission of gas through said conduit, manually-operated means for actuating said valve, automatically acting means for restoring said manually-operated valve-operating means to operative position, an air-valve controlling the admission of air to said mixer-chamber, and means connecting said gas-valve operating means with said air-valve operating means, whereby the latter is actuated in the actuation of the former.

2. In a lamp, the combination of a Bunsen burner equipped with a mantle, a conduit through which gas is admitted to the mixer-chamber of the Bunsen burner, a valve controlling the admission of gas through said conduit, manually-operated means for actuating said valve, automatically acting means for restoring said manually-operated valve-operating means to operative position, an air-valve controlling the admission of air to said mixer-chamber, and means connecting said gas-valve operating means with said air-valve operating means, whereby the latter is actuated in such timed relation with the former as to cause it to be opened subsequent thereto.

3. In a lamp, the combination of a Bunsen burner, a conduit through which gas is admitted to the mixer-chamber thereof, a valve controlling said conduit, an air-valve controlling the admission of air to said mixer-chamber, an actuating lever connected with said first named valve, manually-operated means connected to said lever, means connected with said manually-operated means for automatically restoring said lever to its operative position, and a rod having lost-motion connection with said lever and having connection with said air-valve.

4. In a lamp, the combination of a Bunsen burner, a vertical slidable valve controlling the admission of air to said mixer-tube, a gas-conduit through which gas is admitted to said mixer-chamber, a valve controlling said gas conduit, an actuating lever connected with said second named valve, manually-operated means connected with said lever for actuating the same, means connected with said manually-operating means for automatically restoring said lever to its op-

70
75
80
85
90
95
100
105
110
115
120
125
130

erative position, and connecting means between said lever and said air-valve, constructed and arranged to open said air-valve after said gas-valve has been turned sufficiently to first admit gas to the mixer tube.

5 5. In a lamp, the combination of a pipe section equipped with a disk, a mixer-tube section rising from said disk, a divisible bracket-ring carried by the lower end of
10 said pipe section, and an automatic valve device carried by said divisible ring and comprising a member supported by said ring and provided with a passage communicating with said pipe section, a cap-piece surmounting said last-named member and having
15 an orifice presented to the mixer-tube, and an automatic valve in said cap-piece controlling said orifice.

20 6. In a lamp, the combination with the mixer-tube of a Bunsen burner, of a pipe section having a ring section former integrally therewith, a ring section disconnectibly joined to said first-named ring-section, and an automatic valve device comprising a
25 member clampingly secured between said ring sections and having a passage communicating with said pipe section, a cap-piece connected with said last-named member and having an orifice presented to the mixer-tube, and a gas-actuated valve controlling
30 said orifice.

7. In a lamp, the combination with the mixer-tube of a Bunsen burner, of a gas conduit having an orifice presented to said
35 mixer-tube, an air-valve controlling the admission of air to said mixer-tube, a valve controlling said gas conduit and equipped with an actuating lever, a rod connected with said air-valve, and a slotted arm carried by said lever and receiving said rod,
40 said rod equipped with a stop, whereby, during the actuation of said lever said rod will be lifted to elevate said air-valve.

8. In a lamp, the combination with a burner
45 and a supply pipe, of a valve equipped with an actuating lever, a shiftable slide connected with said lever, a flexible member depending from said slide through the medium of which the slide may be depressed to
50 actuate the lever, and a counterweight device connected with said slide and serving automatically to shift the same when it is released after actuation of the valve.

9. In a lamp, the combination with the
55 supply pipe thereof, of a valve, a guide connected therewith having a substantially straight lower surface and a double-incline upper surface, a slide mounted on said guide,

a flexible member serving to lower said slide and actuate the valve, and slide-shifting
60 means serving to elevate and shift the slide after actuation of the valve.

10. The combination with the supply pipe of a lamp, of a valve equipped with a two-arm lever, a guide member connected with
65 said lever having a straight lower end and a double-incline upper edge, a slide mounted on said guide provided with a small bearing adapted to engage the upper edge of said guide, a flexible member connected with and
70 serving to lower said slide, and a counterweight connected with and serving to elevate and shift said slide after actuation of the valve.

11. The combination with the supply pipe
75 of a lamp, of a valve equipped with a guide member, or track, having notches near its opposite ends, a slide connected with said track, a flexible member depending from said slide, and a counterweight device connected
80 with said slide and serving to elevate and shift the same after actuation of said valve.

12. In a lamp, the combination of a disk, a mixer-tube section rising therefrom, a
85 chimney equipped at its base portion with globe-engaging means, a tubular carrying-member connected with and depending from said disk and provided with bayonet-joint slots, and a tubular globe support provided
90 internally with studs adapted to engage said bayonet-joint slots.

13. In a lamp, the combination of a chimney, a supply pipe, a mixer-tube and a surmounting mixer-chamber, burner-tubes
95 connected with said mixer-chamber and equipped with depending burner-tips, means for controlling the passage of gas through said supply pipe to said mixer-tube, and an internal flue removably supported on said
100 burner-tubes.

14. In a lamp, the combination of a chimney, a supply pipe, a mixer-tube and a surmounting mixer-chamber, burner-tubes
105 connected with said mixer-chamber and equipped with depending burner-tips, means for controlling the passage of gas through said supply pipe to said mixer-tube, and an internal removable flue having its lower portion encircling said burner-tubes and its
110 upper portion extending loosely into the lower portion of said chimney.

JOHN DOORENBOS.

In presence of—

R. A. RAYMOND,
R. A. SCHAEFER.