



- (51) International Patent Classification: *F24F 3/16* (2006.01)
- (21) International Application Number: PCT/EP2015/081098
- (22) International Filing Date: 23 December 2015 (23.12.2015)
- (25) Filing Language: English
- (26) Publication Language: English
- (30) Priority Data:
PCT/CN2014/094774
24 December 2014 (24.12.2014) CN
15158077.6 6 March 2015 (06.03.2015) EP
- (71) Applicant: **KONINKLIJKE PHILIPS N.V.** [NL/NL];
High Tech Campus 5, 5656 AE Eindhoven (NL).
- (72) Inventor: **SCHEJA, Michael Martin**; c/o High Tech
Campus 5, 5656 AE Eindhoven (NL).
- (74) Agents: **STEENBEEK, Leonardus Johannes** et al.; High
Tech Campus 5, 5656 AE Eindhoven (NL).
- (81) Designated States (*unless otherwise indicated, for every
kind of national protection available*): AE, AG, AL, AM,
AO, AT, AU, AZ, BA, BB, BG, BH, BN, BR, BW, BY,
BZ, CA, CH, CL, CN, CO, CR, CU, CZ, DE, DK, DM,
DO, DZ, EC, EE, EG, ES, FI, GB, GD, GE, GH, GM, GT,
HN, HR, HU, ID, IL, IN, IR, IS, JP, KE, KG, KN, KP, KR,
KZ, LA, LC, LK, LR, LS, LU, LY, MA, MD, ME, MG,
MK, MN, MW, MX, MY, MZ, NA, NG, NI, NO, NZ, OM,
PA, PE, PG, PH, PL, PT, QA, RO, RS, RU, RW, SA, SC,
SD, SE, SG, SK, SL, SM, ST, SV, SY, TH, TJ, TM, TN,
TR, TT, TZ, UA, UG, US, UZ, VC, VN, ZA, ZM, ZW.

[Continued on next page]

(54) Title: AIR TREATMENT

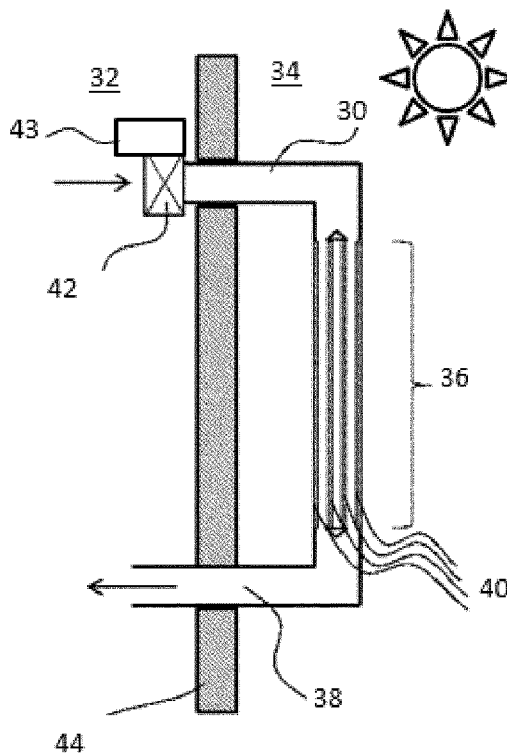

FIG. 3

(57) Abstract: An air treatment system uses a gas exchange unit (36) between the air of first (32) and second (34) spaces. This enables an air refreshing function to be achieved without resulting in additional exposure to particulate contaminants.



(84) Designated States (*unless otherwise indicated, for every kind of regional protection available*): ARIPO (BW, GH, GM, KE, LR, LS, MW, MZ, NA, RW, SD, SL, ST, SZ, TZ, UG, ZM, ZW), Eurasian (AM, AZ, BY, KG, KZ, RU, TJ, TM), European (AL, AT, BE, BG, CH, CY, CZ, DE, DK, EE, ES, FI, FR, GB, GR, HR, HU, IE, IS, IT, LT, LU, LV, MC, MK, MT, NL, NO, PL, PT, RO, RS, SE, SI, SK, SM, TR), OAPI (BF, BJ, CF, CG, CI, CM, GA, GN, GQ, GW, KM, ML, MR, NE, SN, TD, TG).

Declarations under Rule 4.17:

— *as to applicant's entitlement to apply for and be granted a patent (Rule 4.17(ii))*

Published:

— *with international search report (Art. 21(3))*

Air treatment

FIELD OF THE INVENTION

This invention relates to an apparatus and method for fresh air management in confined spaces, such as treatment of air in indoor spaces.

5 BACKGROUND OF THE INVENTION

Factors with significant negative effect on indoor air quality and freshness include the presence and activity of the inhabitants, and the furnishings in the room.

Inhabitants continuously consume oxygen, produce CO₂, and emit a large variety of vapors. Substances such as formaldehyde are released from insulation materials,
10 pressed wood products etc..

Since the air exchange is limited in buildings, especially in apartments without heating, ventilation and air conditioning (HVAC) systems and when windows are kept closed, certain substances accumulate leading to a decrease in air quality and freshness. Opening the window is a widely used practice to refresh the indoor air by allowing
15 accumulated gasses to escape and reach lower concentrations. At the same time, oxygen concentrations can increase to the outdoor levels. Another approach to improve the indoor air quality is the use of fresh air intake systems or air purifiers. Each approach is associated with certain disadvantages as described below.

One important parameter which discriminates gas molecules from particulate
20 matter is their size. For example, pollen particles have a diameter in the range 10 to 100 μm, smog particles have a diameter in the range 0.01 to 1 μm and gaseous contaminants have a diameter below 0.01 μm. Many different types of particle can be classified according to their range of sizes, as will be well known to those skilled in the art. Significantly, gaseous contaminants are of smaller size than particulate contaminants.

25 As a result, fibrous materials, membranes and the like can be used for separation of target particles from a gas stream. By choosing a filter with a certain pore size, particles having a larger size can be excluded from crossing these filter layers while allowing gas molecules to pass. The transport of gas molecules through membranes occurs either in

the form of viscous type flow (convective/non-diffusive) in the case of porous membranes or by diffusion in non-porous membranes.

Fig. 2 shows the four main mechanisms for the flow of gas through pores and dense membranes, as shown in the PhD thesis Gas Transmission Through Microporous Membranes by Tacibaht Turel that discusses protective clothing material as a barrier against harmful gases or vapor while allowing moisture vapor and air passage through the material.

Fig. 2(a) shows viscous flow, Fig. 2(b) shows Knudsen flow, Fig. 2(c) shows surface flow (molecular sieving) and Fig. 2(d) shows diffusion through a material.

Transport is generally driven by concentration or pressure differences. In dense membranes, transport is driven by pure diffusion. In the case of fibrous materials and porous membranes, convective transfer, which is driven by a pressure difference, plays an important role in addition to diffusion.

As mentioned above, opening the window represents one simple option to refresh the indoor air. However, since particle concentrations (such as PM_{2.5} i.e. particles of 2.5 µm diameter and less, PM₁₀ i.e. particles of 10 µm diameter and less, dust, pollen etc.) are often higher outdoors than indoors, opening the window will rapidly increase the indoor concentration of these pollutants.

There is also potentially a rapid drop or rise of room temperature in dependence on the outdoor temperature. There is also a problem of noise disturbance from traffic etc..

Fig. 1 shows in simplified form a fresh air intake system. Air enters the building through an air intake 10, and it then passes through a filter 12 driven by a fan 14. Air intake systems such as shown in Fig. 1 represent another option to refresh indoor air by guiding outdoor air into a building. Since high concentrations of particulates are often present in outdoor air, they are again introduced into the building together with the incoming "fresh" air. Particle filters can be used to remove these particles before introducing the air into the building. The disadvantage of this approach is that the lifetime of such filters is extremely limited, especially in environments with high particulate concentration in outdoor air (such as most cities in China).

A similar problem occurs with air purifiers. As long as the window is kept closed, available air purifiers can usually bring the indoor particle concentration to a satisfactory low level in a relatively short time. However, opening the window is still necessary to refresh the indoor air (in order to decrease CO₂ concentration or the concentrations of other pollutants originating from indoor sources, and/or to increase the

oxygen concentration). With open windows and high outdoor particle concentrations, current air purifiers are not able to maintain a low particle concentration due to the continuous influx of new particles from the outside.

5 SUMMARY OF THE INVENTION

It is an object of the invention to provide an improved air treatment. The invention is defined by the independent claims. The dependent claims define advantageous embodiments.

10 According to examples in accordance with an aspect of the invention, there is provided an air treatment system, comprising:

a first passageway for extending between a first space and a second space;
a gas exchange unit coupled to the first passageway, and for mounting in the second space, the first passageway functioning as an input to the gas exchange unit; and
15 a second passageway for extending between the second space and the first space, the second passageway functioning as an output from the gas exchange unit.

This system enables an exchange of gas molecules between first and second spaces, but it can prevent particulates from passing between the spaces. The spaces are preferably indoor and outdoor spaces. The system enables refreshing of indoor air for example by rebalancing the relative concentrations of oxygen and carbon dioxide. The gas
20 exchange unit may function essentially by diffusion, and the materials used can be selected to prevent particulate material (larger than the gas molecules) from being exchanged. Thus, outdoor particulate pollution can be prevented from entering the indoor space. Thus, the gas exchange unit is configured such that when a concentration of a particular gas in air present in the first space is higher or lower than a concentration of the particular gas in air present in
25 the second space, the gas exchange unit ensures that concentration levels of that gas in the first and the second space are balanced. The gas concentration gradient triggers the gas exchange to balance gas concentrations between the first and the second space. Hence, the gas exchange unit is designed for that purpose. A material permeable to the particular gas components present in the gas exchange unit allows this balancing of gas concentrations. In
30 embodiments, the gas exchange unit is further configured to block transport of particulates from the first to the second space and/or vice versa. The proposed system allows ventilation of the first space without, for example, opening windows which would cause particulates to enter the first space.

The first space may be an indoor space and the second space may be an outdoor space. In this case, the gas exchange unit is mounted outside.

5 Instead, the first space may be an outdoor space and the second space may be an indoor space. In this case, the gas exchange unit is mounted inside. The choice of which option is appropriate may depend on factors such as noise pollution, aesthetics etc..

10 The gas exchange unit preferably comprises a layered structure, wherein the layers extend in a plane parallel to the general direction of passage of air through the gas exchange unit. The air thus passes along the surface of the layers, and diffusion takes place through the layers to tend towards balancing concentrations. The layers may then have a large surface area compared to the cross sectional area of the passageways.

15 The layered structure may include at least one layer which is at least partially permeable to O₂ and at least one layer which is at least partially permeable to CO₂. The layered structure may be formed of identical layers, or different layers which are selected for gas exchange of specific targets. Thus, one or more layers may be permeable to both CO₂ and O₂.

There may also be at least one layer which is at least permeable to formaldehyde. This enables the reduction in concentration of formaldehyde in an indoor space.

20 The gas exchange unit for example may comprise microporous membranes and/or fibrous materials. The gas exchange unit may comprise a polybenzimidazole membrane or membranes and/or a silicon membrane or membranes.

A gas driving arrangement may be used for driving gas through the gas exchange unit. This may be a fan, compressor pump or other suitable means.

25 A controller is preferably provided for controlling the gas driving arrangement to alter the flow rate. Control of the flow rate may be used to control the gas transfer characteristics. For example the controller may enable positive pressure or negative pressure to be applied in a selective manner to the gas exchange unit. This can be used to promote increased flow between the indoor and outdoor spaces, or between the outdoor and indoor spaces. In embodiments, the controller is configured to apply a positive pressure or a negative
30 pressure to the gas exchange unit in a selective manner. For example, the controller may be configured to sequentially apply a positive pressure followed by a negative pressure or vice versa.

The invention also provides an air treatment method, comprising:
passing air from a first space to a second space;

in the second space, passing the air through a gas exchange unit;
balancing concentrations of a gas in the air between the first and the second space via the gas
exchange unit; and

passing the air from the gas exchange unit back to the first space.

5 The method may further comprise:

driving the air from the first space to the second space using a gas driving
arrangement; and

controlling the gas driving arrangement to deliver a positive pressure in the
gas exchange unit relative to outside the gas exchange unit at some times and a negative
10 pressure at other times.

The ability to control the pressure in the gas exchange unit enables different
modes of operation, for example for different gas flow characteristics or even a regeneration
function.

These and other aspects of the invention will be apparent from and elucidated
15 with reference to the embodiments described hereinafter.

BRIEF DESCRIPTION OF THE DRAWINGS

Examples of the invention will now be described in detail with reference to the
accompanying drawings, in which:

20 Fig. 1 shows a known fresh air system;

Fig. 2 shows known gas flow characteristics;

Fig. 3 shows a first example of air treatment system in accordance with the
present invention;

Fig. 4 shows the system of Fig. 3 in more detail;

25 Fig. 5 shows different ways to control the flow of air through the gas exchange
unit; and

Fig. 6 shows a second example of air treatment system in accordance with the
present invention.

30 DETAILED DESCRIPTION OF THE EMBODIMENTS

Throughout the description reference is made to “particulates”. These
particulates may be pollen, dust, ash, bacteria or any other harmful material which may be
present in air. These particulates are particularly larger than the gas components of which the
concentration in air is balanced between the first and the second space. The material present

in the gas exchange unit may be adapted to allow passing through of particular gas components and blocking of such particulates.

The invention provides an air treatment system which uses a gas exchange unit between the air of first and second spaces. This enables an air refreshing function to be achieved without resulting in additional exposure to particulate contaminants.

Fig. 3 shows a first example of an air treatment system, comprising a first passageway 30 for extending between a first space 32 and a second space 34. A gas exchange unit 36 is coupled to the first passageway 30 and is mounted in the second space 34. The first passageway 30 delivers air to the gas exchange unit from the first space 32. A second passageway 38 extends between the second space 34 and the first space 32 and returns air (after gas exchange) to the first space 32.

The gas exchange unit 36 comprises gas exchange layers 40.

A fan 42 provides an air flow through the gas exchange unit 36. The fan is controlled by a control unit 43 which can perform various functions as described below.

In the example of Fig. 3, the first space 32 is an indoor space and the second space 34 is an outdoor space (as represented schematically by the sun symbol), separated by an exterior wall 44 of a building.

The fan drives the intake of indoor air which is to be made fresher into the apparatus. In this embodiment, the fan 42 is located on the indoor side. The indoor air is guided through the wall 44 and into the gas exchange unit 36 located on the opposite side of the wall (outdoors in this case). When passing through the gas exchange unit 36, the air flows in parallel with the gas exchange layers 40.

Fig. 4 shows the working principle in more detail and shows an enlarged portion of the gas exchange unit 36. Three types of air constituent are shown. One part is the oxygen (small open circles) associated with fresh air. Another part is the gas components associated with indoor air which is no longer considered to be fresh, such as CO₂ (carbon dioxide) and VOCs (volatile organic compounds). A third part is the particular matter "PM", including pollen, dust, ash, bacteria, etc..

The outdoor air has a higher concentration of oxygen and a higher concentration of particulate matter (such as pollution). The indoor air has a higher concentration of CO₂ and some other gaseous components such as formaldehyde.

The two spaces are separated by the membranes within the gas exchange unit. Gases pass across the membranes, to tend to balance the concentrations.

The incoming air stream is guided into the gas exchange unit in parallel with the gas exchange layers 40. The gas exchange layers comprise a thin interface which allows gas molecules to pass the membrane while holding back particulates. Although dense membranes might be used in certain applications, it is preferred to use membranes such as microporous membranes. Other options such as fibrous materials, meshes, grids and the like may be also used in certain cases.

Depending on the gas exchange layer material, the flow will be primarily driven either by convection or by diffusion. Since gases such as CO₂, odors, certain VOCs etc. are continuously produced by the inhabitants or released from other indoor sources, their indoor concentrations are higher compared to outdoor air. The resulting concentration gradient is used to drive the gas exchange and refresh the indoor air.

The same applies to the fresh air components such as O₂, which will diffuse from the outside along the concentration gradient. Thus, gas exchange can be driven by diffusion, a pressure difference (e.g. introduced by the fan) or by a combination of both.

The membranes preferably have high permeability to gases such as O₂ and CO₂ and a thickness in the nanometer up to micrometer range.

As examples, the membranes may be polybenzimidazole (PBI - (poly[2,2'-(m-phenylen)-5,5'-bisbenzimidazole]) membranes and/or silicone membranes.

The membrane thickness and material will be selected to achieve a desired permeability for the target gases. A suitable thickness may for example be around 1 mm. In general, the membrane thickness is likely to be in the range 0.1 mm to 5 mm.

The total area of all membrane sheets may for example be a number of square meters, for example around 10 m². In general, the total area is likely to be in the range 0.5 to 50 m². The total area is achieved by stacking multiple membrane sheets, each of a size selected in dependence on the desired physical size of the gas exchange unit. For example for a desired total membrane area of 10 m², there may be 10 gas exchange layers, each with an area of 1 m², or 20 sheets each with an area of 0.5 m², or 40 sheets each with an area 0.25 m² etc..

The passageways leading to and from the gas exchange unit for example have an area between 5 cm² (corresponding to a diameter of 2.5 cm) and 300 cm² (corresponding to a diameter of around 20 cm).

The permeability of the membranes should be selected to be high for the target gases, for example CO₂ and O₂. For CO₂, ideally the permeability is above 3000 Barrer, and for O₂, ideally the permeability is above 600 Barrer. The SI unit of Barrer relates to the

transport flux of a gas (rate of gas permeation per unit area), per unit trans-membrane driving force (e.g. pressure), per unit membrane thickness:

$$1 \text{ Barrer} = 10^{-10} \text{ cm}^3 \cdot \text{cm} / \text{cm}^2 \cdot \text{s} \cdot \text{cm-Hg}.$$

The figures above show that the membrane layers have a large surface area compared to the cross-sectional areas of the air inlet and air outlet. The low cross-sectional areas of the air inlet and air outlet, together with the relatively low mass transfer rates compared to an open window, significantly reduce the problem of a rapid drop or rise of room temperature to approach the outdoor temperature. It also helps to silence outdoor noise while allowing the exchange of gas molecules.

Furthermore, the air inlet and air outlet may also be arranged to form a heat exchanger, allowing the outflowing air to pre-heat the incoming air during winter or to pre-cool it during summer.

Since the air is guided in parallel with the gas exchange layers, rather than directly through the layers as in the case of conventional air filters, the likelihood of the filter becoming blocked by particles is reduced, which leads to a significantly increased lifetime. Since gas exchange can take place without continuous influx of particulates, a conventional indoor air purifier can be used at the same time, in contrast to the situation where a window is open.

In addition to driving the air into the apparatus and guiding it into the gas exchange unit 36, the fan 42 can also be used to generate and modulate the pressure gradient across the gas exchange layers. This will drive a convective flow and can be used to enhance the transport of gases through the pores.

In one embodiment, the pressure difference can be varied by changing the fan speed. An increase of the fan speed will increase the pressure inside the gas exchange unit 36, hence the pressure difference across the gas exchange layers as shown in Fig. 5(a).

Fig. 5(a) shows pressure versus time for a low fan speed (plot 50) and a high fan speed (plot 52) between fan turn on at time 54 and fan turn off at time 56.

An increase in pressure (referring to the configuration as shown in Fig. 4) will further increase the flow of indoor gases such as CO₂ across the gas exchange layers to the outside. Such an increase in pressure can be realized in a periodic way as shown in Fig. 5(b).

With increased pressure, flow of CO₂ across the membrane is increased, but the influx of O₂ decreased. Reducing the pressure back to the initial value will increase the diffusion of O₂ to the inside along the concentration gradient. The actual mass transfer rates will depend on factors such as selectivity and permeability characteristics of the gas

exchange layers, the pressure, concentration differences, the area and thickness of the gas exchange layers etc.. These parameters can be used to design embodiments optimized for specific scenarios.

Negative pressure can be generated in the gas exchange unit, e.g. by reversing the direction of fan rotation. In this case (and again referring to the configuration of Fig. 4), the inflow of O₂ from the outside can be further enhanced. Using this principle, embodiments can be realized which enable a timed pattern with periods of enhanced influx of “fresh air components” followed by enhanced outflow of “un-fresh air components” as shown in Fig. 5(c).

Many different pressure profiles can be generated by changing the speed of the fan and its direction. This can be simply realized e.g. by changing and/or reversing the polarity of the motor which drives the fan. Higher pressure differences can be achieved when a vacuum pump or compressor is used instead of the fan.

The pressure difference across the gas exchange layer can also be modulated by other means than the fan, for instance by regulating the diameter of air outlet, which can be done e.g. by using an aperture-like structure. The more the aperture is closed down at a given fan speed, the higher the pressure in the gas exchange unit.

Approaches may be taken to regenerate the gas exchange layer. For example, the air pressure inside the gas exchange unit may be reversed and raised to values above the normal operation pressure, for example as shown in Fig. 5(d).

The gas exchange unit as a whole may be removable from the device and washed. Optionally, the gas exchange layers can be attached to the gas exchange unit in a removable manner so that just the layers can be washed separately or exchanged against new ones.

The example above places the heat exchanger unit outside. For certain situations it might be desirable to place the gas exchange unit 36 at the indoor side 34 as shown in Fig. 6. In this case, the fan 42 may be located in front of the air inlet at the outdoor side, but equally it may be located at the air outlet.

In this case, the outdoor particulates "PM" are retained within the gas exchange unit rather than being kept out as in the example of Fig. 4. However, the same concept of gas exchange across the membranes applies.

This arrangement may be of advantage when more powerful fans, compressors or vacuum pumps generating significant noise are used. Modes of operation with negative pressure inside the gas exchange may be preferred (with the fan at the outlet side 38 rather

than the inlet side 30 as shown in Fig. 6), especially when outdoor particulate concentrations are high. This will have a positive effect on the lifetime of the gas exchange layers.

The apparatus and method can be used to improve the freshness and quality of indoor air. It can work as a stand-alone solution, but also in combination with indoor air purifiers. In the latter case, it overcomes the dilemma of fresh air supply (O₂ inflow, CO₂ removal etc.) which usually occurs when an air purifier is used indoors. Furthermore, VOC filters of air purifiers could be simplified or removed, since VOCs originating from indoor sources can be transferred to the outside without the need of filtration.

The system of the invention can be used in domestic homes, but also in commercial buildings such as offices, hospitals and factories.

Other variations to the disclosed embodiments can be understood and effected by those skilled in the art in practicing the claimed invention, from a study of the drawings, the disclosure, and the appended claims. In the claims, the word "comprising" does not exclude other elements or steps, and the indefinite article "a" or "an" does not exclude a plurality. The mere fact that certain measures are recited in mutually different dependent claims does not indicate that a combination of these measures cannot be used to advantage.

Any reference signs in the claims should not be construed as limiting the scope.

CLAIMS:

1. An air treatment system, comprising:
 - a first passageway (30) for extending between a first space (32) and a second space (34);
 - a gas exchange unit (36) coupled to the first passageway (30), and for mounting in the second space (34), the first passageway functioning as an input to the gas exchange unit; and
 - a second passageway (38) for extending between the second space (34) and the first space (32), the second passageway functioning as an output from the gas exchange unit;
- 10 wherein the gas exchange unit is configured such that when a concentration of a gas in air present in the first space is higher or lower than a concentration of the gas in air present in the second space, the gas concentrations are balanced between the first and the second space.
- 15 2. An air treatment system as claimed in claim 1, wherein the first space (32) is an indoor space and the second space (34) is an outdoor space.
3. An air treatment system as claimed in claim 1, wherein the first space (32) is an outdoor space and the second space (34) is an indoor space.
- 20 4. An air treatment system as claimed in any one of claims 1 to 3, wherein the gas exchange unit (36) comprises a layered structure having layers (40) extending in a plane parallel to the general direction of passage of air through the gas exchange unit (36).
- 25 5. An air treatment system as claimed in claim 4, wherein the layered structure includes at least one layer which is at least partially permeable to O₂, and at least one layer which is at least partially permeable to CO₂.

6. An air treatment system as claimed in any one of claims 1 to 5, wherein the gas exchange unit (36) comprises one or more microporous membranes.

7. An air treatment system as claimed in any one of claims 1 to 6, wherein the gas exchange unit comprises one or more fibrous material membranes.

5

8. An air treatment system as claimed in any one of claims 1 to 7, wherein the gas exchange unit (36) comprises a polybenzimidazole membrane or membranes and/or a silicon membrane or membranes.

10 9. An air treatment system as claimed in any one of claims 1 to 8, further comprising a gas driving arrangement (42).

10. An air treatment system as claimed in claim 9, wherein the gas driving arrangement (42) comprises a fan or compressor pump.

15

11. An air treatment system as claimed in claim 9 or 10, further comprising a controller (43) for controlling the gas driving arrangement (42) to alter the flow rate; and wherein the controller is configured to apply a positive pressure or a negative pressure to the gas exchange unit in a selective manner.

20

12. An air treatment method, comprising:
passing air from a first space (32) to a second space (34);
in the second space (34), passing the air through a gas exchange unit (36);
balancing concentrations of a gas in the air between the first and the second
25 space via the gas exchange unit; and
passing the air from the gas exchange unit (36) back to the first space (32).

13. An air treatment method as claimed in claim 12, wherein the first space (32) is an indoor space and the second space (34) is an outdoor space, or the first space (32) is an
30 outdoor space and the second space (34) is an indoor space.

14. An air treatment method as claimed in claim 12 or 13, wherein the gas exchange unit (36) comprises a layered structure having layers (40) extending in a plane parallel to the general direction of passage of air through the gas exchange unit.

15. An air treatment method as claimed in any one of claims 12 to 14, further comprising:

driving the air from the first space to the second space using a gas driving arrangement; and

5 controlling the gas driving arrangement to deliver a positive pressure in the gas exchange unit relative to outside the gas exchange unit at some times and a negative pressure in the gas exchange unit relative to outside the gas exchange unit at other times.

1/5

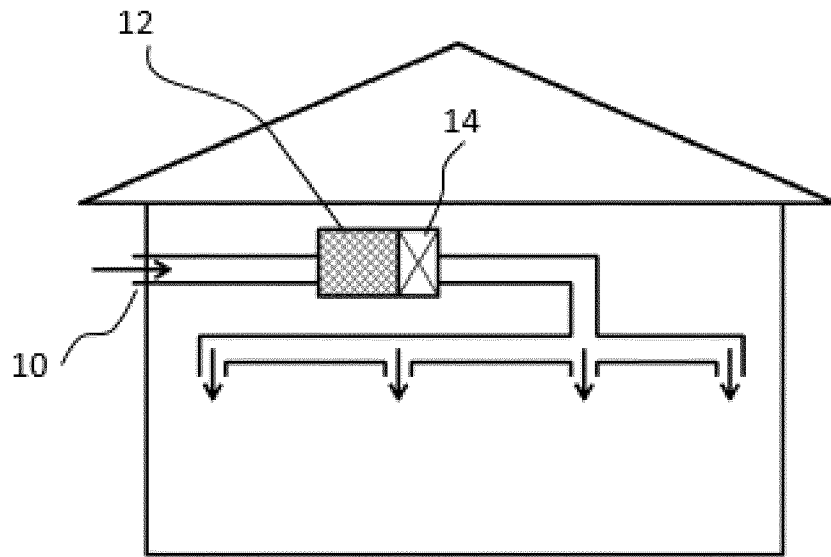

FIG. 1

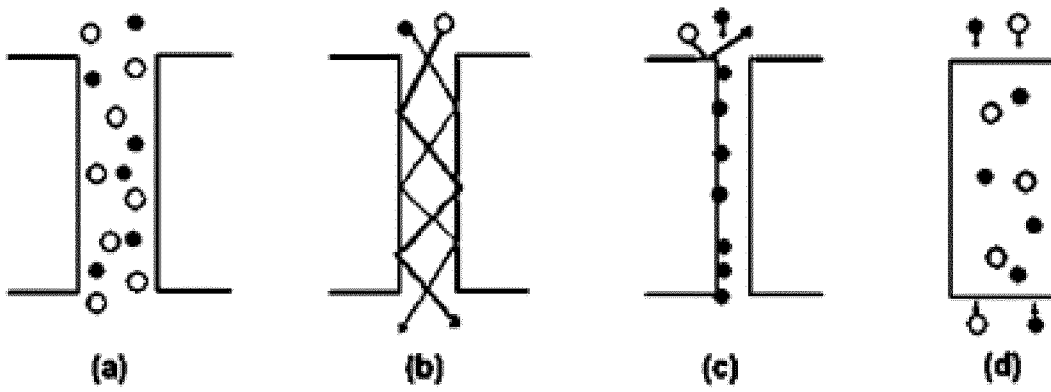

FIG. 2

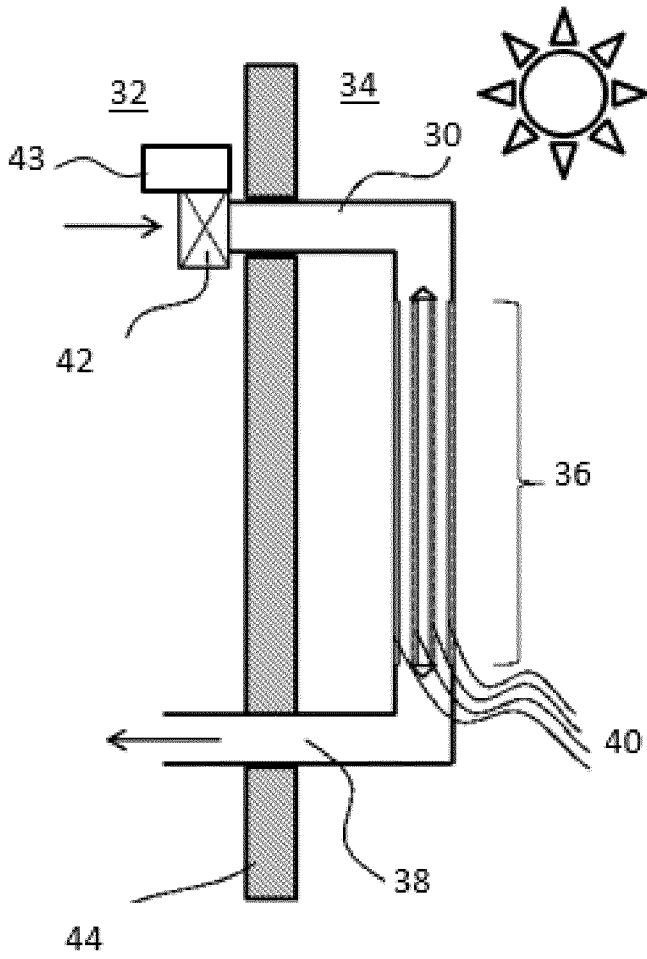

FIG. 3

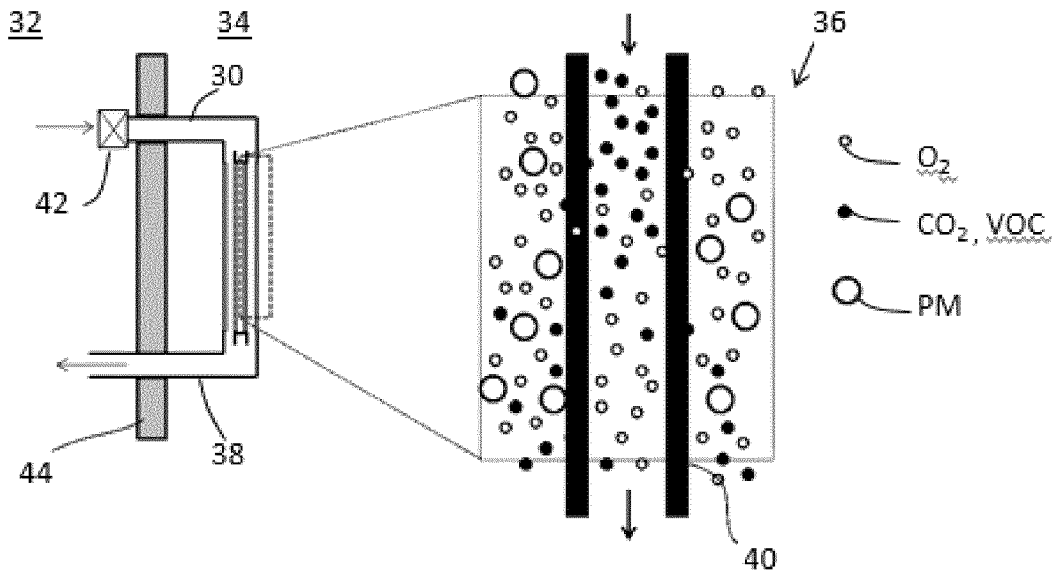

FIG. 4

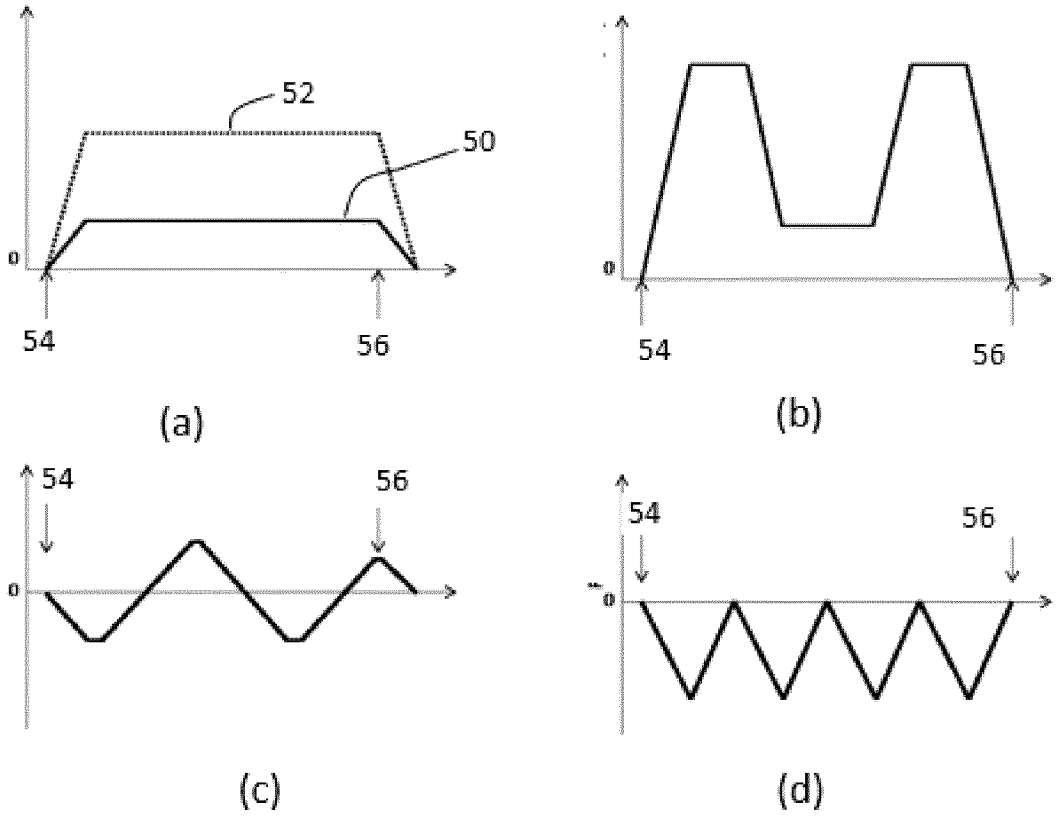

FIG. 5

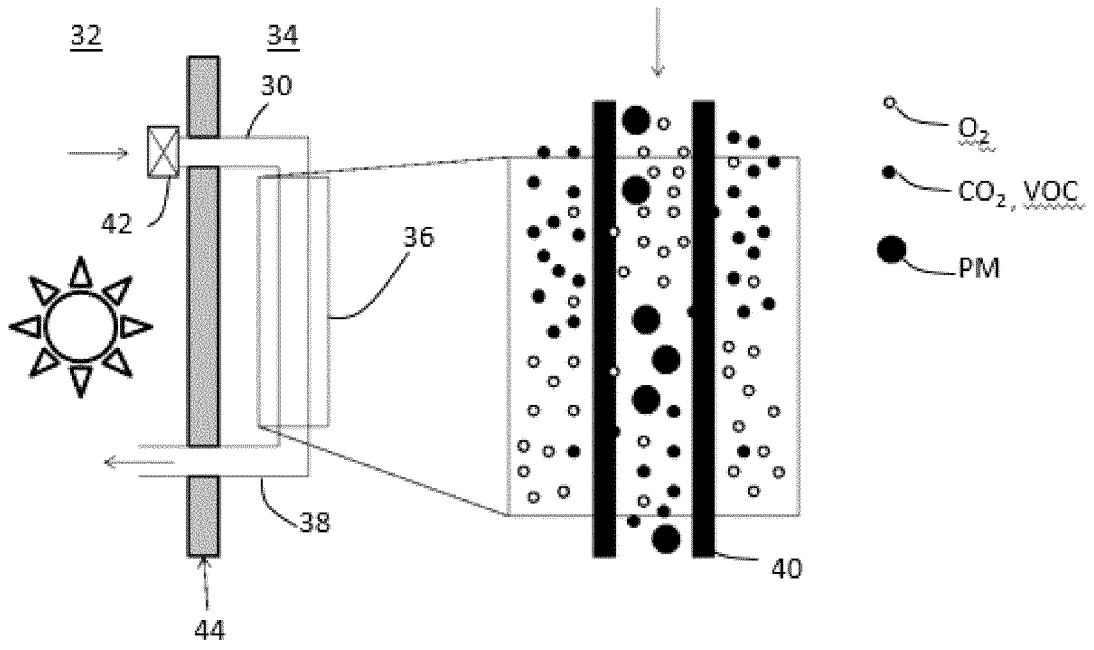

FIG. 6

INTERNATIONAL SEARCH REPORT

International application No
PCT/EP2015/081098

A. CLASSIFICATION OF SUBJECT MATTER
INV. F24F3/16
ADD.
According to International Patent Classification (IPC) or to both national classification and IPC

B. FIELDS SEARCHED
Minimum documentation searched (classification system followed by classification symbols)
F24F

Documentation searched other than minimum documentation to the extent that such documents are included in the fields searched

Electronic data base consulted during the international search (name of data base and, where practicable, search terms used)
EPO-Internal, WPI Data

C. DOCUMENTS CONSIDERED TO BE RELEVANT

Category*	Citation of document, with indication, where appropriate, of the relevant passages	Relevant to claim No.
X	WO 98/25687 A1 (MINNESOTA MINING & MFG [US]) 18 June 1998 (1998-06-18) page 11, line 10 - page 12, line 30 page 21; figures 1,3,4,9; table 2 -----	1-15
X	US 2010/105309 A1 (ISHIBASHI AKIRA [JP]) 29 April 2010 (2010-04-29) paragraph [0090] - paragraph [0099]; figures 3-4 -----	1-15
A	WO 97/03631 A1 (HYPOXICO INC [US]) 6 February 1997 (1997-02-06) page 10, line 25 - page 13, line 10; figures 1,3,5,6 -----	1-15
	-/--	

Further documents are listed in the continuation of Box C.

See patent family annex.

* Special categories of cited documents :

- "A" document defining the general state of the art which is not considered to be of particular relevance
- "E" earlier application or patent but published on or after the international filing date
- "L" document which may throw doubts on priority claim(s) or which is cited to establish the publication date of another citation or other special reason (as specified)
- "O" document referring to an oral disclosure, use, exhibition or other means
- "P" document published prior to the international filing date but later than the priority date claimed

- "T" later document published after the international filing date or priority date and not in conflict with the application but cited to understand the principle or theory underlying the invention
- "X" document of particular relevance; the claimed invention cannot be considered novel or cannot be considered to involve an inventive step when the document is taken alone
- "Y" document of particular relevance; the claimed invention cannot be considered to involve an inventive step when the document is combined with one or more other such documents, such combination being obvious to a person skilled in the art
- "&" document member of the same patent family

Date of the actual completion of the international search 31 March 2016	Date of mailing of the international search report 07/04/2016
Name and mailing address of the ISA/ European Patent Office, P.B. 5818 Patentlaan 2 NL - 2280 HV Rijswijk Tel. (+31-70) 340-2040, Fax: (+31-70) 340-3016	Authorized officer Anconetani, Mirco

INTERNATIONAL SEARCH REPORT

International application No
PCT/EP2015/081098

C(Continuation). DOCUMENTS CONSIDERED TO BE RELEVANT		
Category*	Citation of document, with indication, where appropriate, of the relevant passages	Relevant to claim No.
A	US 2011/277490 A1 (MEIRAV UDI [US]) 17 November 2011 (2011-11-17) paragraph [0021] - paragraph [0022] paragraph [0028] - paragraph [0030]; figures 2-4 -----	1-15
A	WO 2007/128584 A1 (FINANZIARIA UNTERLAND S P A [IT]; PRUNERI MARCO [IT]) 15 November 2007 (2007-11-15) page 4, line 20 - page 5, line 22; figures 1,4 -----	1-15
A	WO 2006/070182 A2 (WELLMAN DEFENCE LTD [GB]; THOMSEN NIELS ERIK [DK]; CASSIDY STEPHEN [GB] 6 July 2006 (2006-07-06) page 7, line 19 - page 9, line 16; figures 1-4 -----	1-15

INTERNATIONAL SEARCH REPORT

Information on patent family members

International application No

PCT/EP2015/081098

Patent document cited in search report	Publication date	Patent family member(s)	Publication date	
WO 9825687	A1	18-06-1998	AU 2663997 A	03-07-1998
			CA 2272277 A1	18-06-1998
			DE 69732529 D1	24-03-2005
			DE 69732529 T2	05-01-2006
			EP 0946257 A1	06-10-1999
			JP 2001505816 A	08-05-2001
			KR 200000057455 A	15-09-2000
			PL 333978 A1	31-01-2000
			RU 2182512 C2	20-05-2002
			TW 422730 B	21-02-2001
			US 5976220 A	02-11-1999
			US 6248153 B1	19-06-2001
			WO 9825687 A1	18-06-1998
US 2010105309	A1	29-04-2010	JP 3156408 U	24-12-2009
			JP 4451492 B2	14-04-2010
			US 2010105309 A1	29-04-2010
			WO 2008136215 A1	13-11-2008
WO 9703631	A1	06-02-1997	AT 209474 T	15-12-2001
			CA 2227444 A1	06-02-1997
			DE 69617477 D1	10-01-2002
			DE 69617477 T2	01-08-2002
			EP 0959862 A1	01-12-1999
			US 5799652 A	01-09-1998
			WO 9703631 A1	06-02-1997
US 2011277490	A1	17-11-2011	CN 103119376 A	22-05-2013
			JP 2013526697 A	24-06-2013
			KR 20130124158 A	13-11-2013
			US 2011277490 A1	17-11-2011
			WO 2011146478 A1	24-11-2011
WO 2007128584	A1	15-11-2007	EP 2029183 A1	04-03-2009
			WO 2007128584 A1	15-11-2007
WO 2006070182	A2	06-07-2006	AU 2005321078 A1	06-07-2006
			DK 1831596 T3	03-06-2013
			EP 1831596 A2	12-09-2007
			ES 2406413 T3	06-06-2013
			JP 4787268 B2	05-10-2011
			JP 2008525760 A	17-07-2008
			WO 2006070182 A2	06-07-2006