

(19)



(11)

**EP 3 842 587 B1**

(12)

**EUROPEAN PATENT SPECIFICATION**

(45) Date of publication and mention of the grant of the patent:  
**03.01.2024 Bulletin 2024/01**

(51) International Patent Classification (IPC):  
**D06F 58/30** <sup>(2020.01)</sup> **D06F 58/38** <sup>(2020.01)</sup>  
**D06F 103/32** <sup>(2020.01)</sup> **D06F 105/56** <sup>(2020.01)</sup>

(21) Application number: **20210344.6**

(52) Cooperative Patent Classification (CPC):  
**D06F 58/38**; D06F 2103/32; D06F 2105/56

(22) Date of filing: **27.11.2020**

(54) **LAUNDRY DRYING MACHINE**

WÄSCHETROCKNUNGSMASCHINE

MACHINE À SÉCHER LE LINGE

(84) Designated Contracting States:  
**AL AT BE BG CH CY CZ DE DK EE ES FI FR GB GR HR HU IE IS IT LI LT LU LV MC MK MT NL NO PL PT RO RS SE SI SK SM TR**

(30) Priority: **24.12.2019 TR 201921367**

(43) Date of publication of application:  
**30.06.2021 Bulletin 2021/26**

(73) Proprietor: **Arçelik Anonim Sirketi**  
**34445 Istanbul (TR)**

(72) Inventors:  
• **DURAK, Erdinc**  
**34445 ISTANBUL (TR)**

- **ERCAN, Onur**  
**34950 ISTANBUL (TR)**
- **ARSLAN, Sergen Erkan**  
**34950 Istanbul (TR)**
- **ZADEOGLU, Cenkey**  
**34445 ISTANBUL (TR)**
- **TUNA, Mutlu**  
**34445 ISTANBUL (TR)**

(56) References cited:  
**EP-A1- 2 034 086 CN-A- 104 631 073**  
**CN-A- 107 787 383 US-B1- 10 151 061**

**EP 3 842 587 B1**

Note: Within nine months of the publication of the mention of the grant of the European patent in the European Patent Bulletin, any person may give notice to the European Patent Office of opposition to that patent, in accordance with the Implementing Regulations. Notice of opposition shall not be deemed to have been filed until the opposition fee has been paid. (Art. 99(1) European Patent Convention).

## Description

**[0001]** The present invention relates to a laundry dryer enabling the laundry to be dried.

**[0002]** In domestic type drying machines, drying of the laundry is realized by delivering the heated hot air onto the laundry and transferring humidity in the laundry to the hot air. In the state of the art laundry drying machines art which are known as vented laundry drying machines, the ambient air which is taken from the environment by means of a fan is heated by being passed through a heater and the heated hot air is sent into the drum into which the laundry to be dried is placed. The hot air contacts the laundry in the drum and the humidity in the laundry is transferred to the air. The air which absorbs some of the humidity of the laundry is preferably filtered after leaving the drum and discharged back to the outer environment. The laundry drying machine enables the laundry to be dried by performing the cycle explicated above throughout the drying process.

**[0003]** In the state of the art, the laundry drying machines comprise humidity sensors which detect the amount of humidity carried by the laundry in the drum to finalize the drying process. Said humidity sensors are preferably arranged so as to have a plate in the front section of the drying machine and measure a resistance value when the wet laundry items contact the plate. Said resistance value increases as the humidity of laundry contacting the plate decreases. A control unit decides whether the drying process must be finalized based on the resistance value measured by the humidity sensor. However, in such a dryness detection method, most of the time, the drying process is finalized without achieving a homogeneous drying due to the fact that the humidity sensor does not contact each laundry and contacts only some regions of the laundry. Therefore, some of the laundry taken out of the dryer or some parts of the laundry remain wet, causing user dissatisfaction. Furthermore, the temperature of the environment wherein the laundry drying machine is used affects the operation of the humidity sensor and thus, the drying process cannot be performed effectively.

**[0004]** In the state of the art European Patent Document No. EP2034086, a laundry drying machine is disclosed, wherein the drying process performed in the drum is enabled to be controlled by means of at least one temperature sensor.

**[0005]** Document US10151061B1 describes a process where the control unit measures the ambient temperature of the air not heated by the dryer's heater, compares it to a baseline ambient temperature, and sets an airflow temperature threshold.

**[0006]** The aim of the present invention is the realization of a laundry drying machine which enables the laundry placed into the drum to be dried homogeneously.

**[0007]** The laundry drying machine realized in order to attain the aim of the present invention explicated in the first claim and the respective claims thereof, wherein the

drying of the laundry in the drum is performed by heating the air taken from the outer environment and passing the same through the drum and discharging the same back to the outer environment, comprises a control unit which is in data communication with a temperature sensor configured to detect the temperature of the air leaving the drum and which is configured to at least approximately determine the temperature of the outer environment and the amount of laundry load in the drum by using at least the temperature value detected by the temperature sensor, and to enable the drying process to be realized based on the detected outer environment temperature level and the load level in the drum. In an embodiment of the present invention, the control unit determines the outer environment temperature level so as to be in three categories for example as "hot environment", "cold environment" and "medium temperature environment" and determines the load level in the drum so as to be in categories such as "full load", "low load" and "medium load". The control unit enables the laundry in the drum to be dried homogeneously by means of preferably a single temperature sensor without the need for a humidity sensor by enabling the drying process to be realized based on at least the detected outer environment temperature level and the detected load level in the drum by determining the temperature of the environment wherein the laundry drying machine is placed and the load level in the drum based on the temperature of the air exiting the drum.

**[0008]** According to the present invention, the control unit is configured to check if the temperature of the air exiting the drum detected by the temperature sensor reaches a target temperature value predetermined by the producer based on the temperature levels of the outer environment and the load levels in the drum after determining the temperature level of the outer environment and the load level in the drum, and to finalize the drying process if, after the control process, it is detected that said target temperature value is reached. The target temperature value predetermined by the producer is a temperature value which enables the humidity of the laundry in the drum to be removed almost completely in the corresponding outer environment temperature level and laundry load level. Said target temperature value is determined preferably by means of experiments performed by the producer. In an exemplary embodiment of the present invention wherein a target temperature value of 33 C° is determined for a specific outer environment temperature level and a specific load level and saved in the control unit, the control unit, after determining the outer environment temperature level and the load level in the drum and the corresponding outer environment temperature level and load level in the drum for the target temperature value which is 33 C°, enables the drying process to be finalized when the temperature of the air exiting the drum received from the temperature sensor preferably at certain intervals is greater than or equal to 33 C°.

**[0009]** According to the present invention, the control

unit is configured to check if the temperature of the air exiting the drum detected by the temperature sensor has reached a threshold temperature value predetermined by the producer based on the temperature levels of the outer environment and the loads level in the drum after determining the temperature level of the outer environment and the load level in the drum, and if, after the control process, it is detected that said threshold temperature value is reached, to finalize the drying process after a specific time period, wherein said time period is selected from a plurality of time period values predetermined and saved by the producer based on at least the outer environment temperature level and the load level and corresponds to the detected outer environment temperature level and the load level. The target temperature value predetermined by the producer is a temperature value at which the humidity of the laundry in the drum has a specific value such as 10% in the corresponding outer environment temperature level and load level. Said threshold temperature value is determined preferably by means of experiments performed by the producer. The time which has to pass after the threshold temperature value is reached is determined by the producer such that the drying can be performed homogeneously, based mainly on the temperature levels of the outer environment and the load levels in the drum and based on additional parameters such as the drying program type selected by the user and the power supplied to the laundry drying machine. In an exemplary embodiment of the present invention wherein a threshold temperature value of 30 C° is determined for a specific outer environment temperature value and a specific load level and a 400 second time period value is determined for said outer environment temperature level and said load level and saved in the control unit, the control unit, after determining the outer environment temperature level and the load level in the drum and the corresponding outer environment temperature level and load level in the drum for the threshold temperature value which is 30 C°, enables the drying process to be finalized at the end of a time period of 400 seconds if the temperature of the air exiting the drum is greater than or equal to 30 C°.

**[0010]** In an embodiment of the present invention, in order to determine the temperature level of the outer environment, the control unit is configured to calculate the average of the temperature values of the air taken from the outer environment for a certain amount of time before the heater is operated, compare the average value of the temperature of the outer environment with at least one first reference temperature value predetermined and saved by the producer, and to select, based on the result of the comparison, the corresponding outer environment temperature category among at least two predetermined categories. In this embodiment, if the average outer environment temperature value is detected to be greater than the first reference temperature value after comparing the calculated average outer environment temperature value with the at least one reference temperature

value predetermined and saved by the producer, the temperature of the environment outside the body is categorized as for example "hot environment", and if the average outer environment temperature value is detected to be less than the first reference temperature value, the temperature of the environment outside the body is categorized as for example "cold environment". In an exemplary embodiment of the present invention wherein a first reference temperature value of 24 C° is determined and the average temperature of the air taken from the outer environment for 15 seconds is calculated as 23 C°, the control unit compares the temperature value of the outer environment which is 23 C° and the first reference temperature value which is 24 C° and determines that the average temperature level of the ambient air is less than the first reference temperature value, in other words, that 23 C° is less than 24 C° and categorizes the temperature level of the environment as "cold environment". In an exemplary embodiment of the present invention wherein a first reference temperature value of 24 C° is determined and the average temperature of the air taken from the outer environment for 15 seconds is calculated as 25 C°, the control unit compares the temperature value of the outer environment which is 25 C° and the first reference temperature value which is 24 C° and determines that the average temperature value of the ambient air is greater than the first reference temperature value, in other words, that 25 C° is greater than 24 C° and categorizes the temperature level of the environment as "hot environment".

**[0011]** In an embodiment of the present invention, in order to determine the temperature level of the outer environment, the control unit is configured to compare the average of the air temperature values detected for a specific amount of time before the heater is operated and two different reference temperature values predetermined and saved by the producer. In an exemplary embodiment wherein the first first reference temperature value is assumed to be greater than the second first reference temperature value, if the average temperature value of the outer environment is detected to be greater than the first first reference temperature value after the average temperature value of the outer environment calculated by the control unit and the two different first reference temperature values predetermined and saved are compared, the temperature of the outer environment is categorized as "hot environment", if the average temperature value of the outer environment is detected to be smaller than the second first reference temperature value, the temperature of the outer environment is categorized as "cold environment" and if the average temperature value of the outer environment is detected to be less than the first first reference temperature value and greater than the second first reference temperature value, the temperature of the outer environment is categorized as "medium temperature environment". In an exemplary embodiment of the present invention wherein a first first reference temperature value of 30 C° and a second first

reference temperature value of 15 C° are determined and the average temperature of the air taken from the outer environment for 15 seconds before the heater is operated is calculated as 25 C°, the control unit compares the average temperature value of the outer environment which is 25 C° with the first first reference temperature value which is 30 C° and the second first reference temperature value which is 15C° and determines that the average temperature value of the ambient air is less than the first first reference temperature value, in other words, that 25 C° is less than 30 C° and the average temperature value of the ambient air is greater than the second first reference temperature value, in other words, that 25 C° is greater than 15 C° and categorizes the temperature of the environment as "medium temperature environment".

**[0012]** In an embodiment of the present invention, in order to determine the laundry load level in the drum, the control unit is configured to determine a second reference temperature value predetermined in relation to the temperature of the outer environment and saved by the producer based on the determined temperature of the outer environment, to calculate the difference between the actual temperature of the air exiting the drum detected by the temperature sensor and said second reference temperature value, to compare the calculated difference with at least one threshold difference value predetermined and saved by the producer and, to categorize, based on the result of the comparison, the amount of load in the drum based on at least two predetermined categories. In an exemplary embodiment wherein the temperature of the outer environment can be categorized in two categories, namely "hot environment" and "cold environment", two second reference values related to said categories are determined by the producer and in an exemplary embodiment wherein the temperature of the outer environment can be categorized in three categories, namely "hot environment", "cold environment" and "medium temperature environment", three second reference values related to said categories are determined by the producer. In this embodiment, after comparing the calculated difference between the actual temperature of the air exiting the drum detected by the temperature sensor after a certain amount of time and said second reference temperature value with at least one threshold difference value predetermined and saved by the producer, the control unit categorizes the amount of load in the drum for example as "low load" if the calculated difference is greater than the threshold difference value, and categorizes the amount of load in the drum for example as "full load" if the calculated difference is smaller than the threshold difference value. In an exemplary embodiment of the present invention wherein a second reference temperature value which is 23 C° corresponding to an outer environment temperature level which is categorized as a "medium temperature environment" and a threshold difference value of 8 C° are determined and the temperature detected by the temperature sensor for example 300 seconds after the heater is activated is calculated as 25 C°,

after determining the outer environment temperature level to be "medium temperature environment", the control unit calculates the difference between the actual temperature of the air exiting the drum detected by the temperature sensor after a certain amount of time passes after the heater is activated, in other words, the value of 25 C° detected by the temperature sensor after 300 seconds passes after the heater is activated and the second reference temperature value predetermined by the producer and saved in relation to the temperature of the outer environment, in other words, the value of 23 C° which corresponds to the outer environment temperature level which is "medium temperature environment", and reaches the value 2 C°. Then, the control unit compares the calculated difference value which is 2 C° with the threshold difference value predetermined by the producer which is 8 C°, and determines that the calculated difference is less than the threshold difference, in other words 2 C° is less than 8 C° and categorizes the load level in the drum as "full load". In an exemplary embodiment of the present invention wherein a second reference temperature value which is 23 C° corresponding to an outer environment temperature level which is categorized as a "medium temperature environment" by the producer, a first threshold difference value which is 30 C° and a threshold difference value which is 8 C° are determined and the temperature detected by the temperature sensor for example 300 seconds after the heater is activated is calculated as 25 C°, after determining the outer environment temperature level as "medium temperature environment", the control unit calculates the difference between the actual temperature of the air exiting the drum detected by the temperature sensor after a certain amount of time passes after the heater is activated, in other words, the value 25 C° detected by the temperature sensor after 300 seconds passes after the heater is activated and the second reference temperature value predetermined by the producer and saved in relation to the temperature of the outer environment, in other words, the value 23 C° which corresponds to the outer environment temperature level which is "medium temperature environment" and reaches 2 C°. Then, the control unit compares the calculated difference value which is 2 C° with the threshold difference value predetermined by the producer which is 8 C° and determines that the calculated difference is less than the threshold difference, in other words 2 C° is less than 8 C° and categorizes the load level in the drum as "low load".

**[0013]** In an embodiment of the present invention, in order to determine the load level in the drum, the control unit is configured to compare the calculated difference between the actual temperature of the air exiting the drum detected by the temperature sensor a certain amount of time after the heater is activated and said second reference temperature value with two different threshold difference values predetermined and saved by the producer. In an exemplary embodiment wherein the first threshold difference value is greater than the second threshold

difference value, the control unit, after comparing the calculated difference with two threshold difference values predetermined and saved by the producer, the control unit categorizes the amount of load in the drum for example as "low load", if the calculated difference is greater than the first threshold difference value, and categorizes the amount of load in the drum for example as "full load" if the calculated difference is less than the second threshold difference value, and categorizes the amount of load in the drum for example as "medium load" if the calculated difference is less than the first threshold difference value and greater than the second threshold difference value. In an exemplary embodiment of the present invention wherein a second reference temperature value which is 23 C° corresponding to an outer environment temperature level which is categorized as a "medium temperature environment", a first threshold difference value which is 15 C° and a second threshold difference value which is 5 C° are determined and the actual temperature of the air exiting the drum detected by the temperature sensor for example 300 seconds after the heater is activated is calculated as 30 C°, the control unit, after determining the outer environment temperature level as "medium temperature environment", calculates the difference between the actual temperature of the air exiting the drum detected by the temperature sensor after a certain amount of time passes after the heater is activated, in other words, the value 30 C° detected by the temperature sensor 300 seconds after the heater is activated and the second reference temperature value predetermined by the producer and saved in relation to the temperature of the outer environment, in other words, the value 23 C° which corresponds to the outer environment temperature level which is "medium temperature environment", and reaches 7 C°. Then, the control unit compares the calculated difference value which is 7 C° with the first threshold difference value and the second threshold difference value predetermined by the producer which are 15 C° and 5 C° respectively and determines that the calculated difference value is less than the first threshold difference value, in other words 7 C° is less than 15 C° and calculated difference value is greater than the second threshold difference value, in other words 7 C° is greater than 5 C° and categorizes the load level in the drum as "medium load".

**[0014]** By means of the present invention, by estimating the temperature of the environment the laundry drying machine is placed and the load level in the drum using at least the temperature value of the drying air exiting the drum by means of the temperature sensor, the control unit enables the drying process to be performed in a controlled manner at least based on the temperature of the environment and the amount of load and thus, enables the laundry to be dried homogeneously preferably by using a single temperature sensor without the need for using a humidity sensor.

**[0015]** The laundry drying machine realized in order to attain the aim of the present invention is illustrated in the

attached figure, where:

Figure 1 - is the schematic view of the laundry drying machine of the present invention.

**[0016]** The elements illustrated in the figures are numbered as follows:

1. Laundry drying machine
2. Body
3. Drum
4. Fan
5. Heater
6. Temperature sensor
7. Air outlet

**[0017]** The laundry drying machine (1) comprises a body (2); a drum (3) which is positioned in the body (2), which has at least one air inlet opening and an air outlet opening and wherein the drying process is realized; at least one fan (4) which sucks air from the outer environment and directs the same towards the drum (3); at least one heater (5) for heating the ambient air which is sucked before entering the drum (3); a temperature sensor (6) which is configured to detect the temperature of the air exiting the drum (3); and at least one air outlet (7) which enables the air exiting the drum (3) to be discharged from the body (2). In the laundry drying machine (1), during the drying process, the ambient air is sucked from the environment outside the body (2) with the operation of the fan (4), and the ambient air sucked by the fan (4) is sent into the drum (3) after being passed through the heater (5). The hot air which is heated by the heater (5) contacts the laundry in the drum (3) and enables the drying process to be realized by removing the humidity in the laundry. The air humidified in the drum (3) is sent back to the outer environment through the air outlet (7) after passing through the outlet opening of the drum (3). The drying of the laundry placed into the drum (3) is realized by repeating this cycle continuously. The temperature sensor (6) is preferably placed near the air outlet opening of the drum (3) and it is for example, a negative temperature coefficient thermistor (NTC) configured to detect the temperature of the air exiting the drum (3).

**[0018]** The following symbols are used for explicating the laundry drying machine (1) of the present invention:

$T_{avg}$ : The average temperature of the air taken from the outer environment for a certain amount of time before the heater (5) is activated.

$T_{1,ref1}$ : A first first reference temperature value which is predetermined and saved into the control unit by the producer.

$T_{1,ref2}$ : A second first reference temperature value which is predetermined and saved into the control unit by the producer.

$T_{2,ref1}$ : A second reference temperature value which is predetermined specifically for each ambient temperature category and saved into the control unit by the producer.

$T_{1,act1}$ : The temperature of the air exiting the drum (3) detected by the temperature sensor (6) at a specific time after the heater is activated (5).

$\Delta T_{act}$ : The difference between the actual air temperature detected by the temperature sensor (6) at a specific time after the heater (5) is activated and the second reference temperature value corresponding to the related temperature category.

$T_{1,ref1}$ : A first threshold temperature difference value predetermined and saved into the control unit by the producer for the difference between the actual air temperature detected by the temperature sensor (6) at a specific time after the heater (5) is activated and the second reference temperature value corresponding to the related temperature category.

$T_{1,ref2}$ : A second threshold temperature difference value predetermined and saved into the control unit by the producer for the difference between the actual air temperature detected by the temperature sensor (6) at a specific time after the heater (5) is activated and the second reference temperature value corresponding to the related temperature category.

$T_2$ : A target temperature value which is predetermined for each temperature category and load category combination and saved into the control unit by the producer.

$T_{2c}$ : A threshold temperature value which is predetermined for each temperature category and load category combination and saved into the control unit by the producer, and which is lower than the target temperature value.

**[0019]** The laundry drying machine (1) of the present invention comprises at least one control unit which is connected to the temperature sensor (6) so as to be in data communication with the same and which is configured to estimate the temperature level of the environment outside the body (2) and the load level in the drum (3) using at least the temperature value detected by the temperature sensor (6), and enable the drying process to be realized based on the estimated temperature level of the environment outside the body (2) and the estimated load level in the drum (3). The control unit, by estimating the temperature level of the environment wherein the laundry drying machine (1) is placed and the load level in the drum (3), enables the drying process to be realized based on at least these two parameters and thereby, provides a homogeneous drying of the laundry in the drum (3).

**[0020]** According to the present invention, the control unit is configured to check if the temperature of the air exiting the drum (3) detected by the temperature sensor (6) reaches a target temperature value ( $T_2$ ) predetermined based on the temperature level of the outer environment and the load level in the drum (3) after estimating the temperature level of the outer environment and the load level in the drum and to finalize the drying process if, after the control process, it is detected that said target temperature value ( $T_2$ ) is reached. In the preferred em-

bodiment of the present invention, the target temperature value ( $T_2$ ) is determined as a value which enables the laundry in the drum (3) to be dried almost completely in the drying process which is realized when the temperature level of the environment and the load level in the drum (3) are at corresponding values.

**[0021]** In an embodiment of the present invention, the control unit is configured to check if the temperature of the air exiting the drum (3) detected by the temperature sensor (6) has reached a threshold temperature value ( $T_{2c}$ ) predetermined based on the temperature level of the outer environment and the load level in the drum after estimating the temperature level of the outer environment and the load level in the drum (3) and if, after the control process, it is detected that said threshold temperature value ( $T_{2c}$ ) is reached, to finalize the drying process at the end of a specific time period after the threshold temperature value ( $T_{2c}$ ) is reached, wherein said time period is selected from a plurality of time period values predetermined and saved based on at least the outer environment temperature level and the load level and corresponds to the detected outer environment temperature level and the load level in the drum (3). In the preferred embodiment of the present invention, the target temperature value ( $T_2$ ) is determined as a value which enables the laundry in the drum (3) to have a certain amount of humidity in the drying process which is realized when the temperature level of the environment and the load level in the drum (3) are at corresponding values. In the preferred embodiment of the present invention, the time which has to pass after the threshold temperature value ( $T_{2c}$ ) is reached is determined by the producer so that the drying can be performed homogeneously, based mainly on the temperature level of the outer environment and the load level in the drum (3) and based on additional parameters such as the drying program type selected by the user and the power supplied to the laundry drying machine (1).

**[0022]** In an embodiment of the present invention, in order to estimate the temperature level of the environment outside the body (2), the control unit is configured to calculate the average temperature ( $T_{avg}$ ) of the air taken from the outer environment for a specific amount of time before the heater (5) is activated, compare the average temperature ( $T_{avg}$ ) of the outer environment with at least one first reference temperature value ( $T_{1,ref1}$ ) predetermined and saved by the producer, and to select, based on the result of the comparison, the corresponding outer environment temperature category among at least two predetermined categories. In this embodiment, if the average outer environment temperature value ( $T_{avg}$ ) is greater than the first reference temperature value ( $T_{1,ref1}$ ) ( $T_{avg} > T_{1,ref1}$ ) after comparing the calculated average outer environment temperature value ( $T_{avg}$ ) and at least one predetermined and saved first reference temperature value ( $T_{1,ref1}$ ), the temperature of the environment outside the body (2) is categorized as for example "hot environment", if the average outer environment temper-

ature value ( $T_{avg}$ ) is less than the first reference temperature value ( $T_{1,ref1}$ ) ( $T_{avg} < T_{1,ref1}$ ), the temperature of the environment outside the body (2) is categorized as for example "cold environment".

**[0023]** In an embodiment of the present invention, the control unit is configured to compare the calculated average temperature value of the outer environment ( $T_{avg}$ ) with two different first reference temperature values ( $T_{1,ref1}$ ,  $T_{1,ref2}$ ) in order to estimate the temperature level of the environment outside the body (2). In an exemplary embodiment wherein the first first reference temperature value ( $T_{1,ref1}$ ) is greater than the second first reference temperature value ( $T_{1,ref2}$ ), if the average temperature value of the outer environment ( $T_{avg}$ ) is detected to be greater than the first first reference temperature value ( $T_{1,ref1}$ ) ( $T_{avg} > T_{1,ref1}$ ) after the average temperature value of the outer environment ( $T_{avg}$ ) calculated by the control unit and the two different first reference temperature values ( $T_{1,ref1}$ ,  $T_{1,ref2}$ ) predetermined and saved, the temperature of the environment outside the body (2) is categorized as "hot environment", if the average temperature value of the outer environment ( $T_{avg}$ ) is detected to be less than the second first reference temperature value ( $T_{1,ref2}$ ) ( $T_{avg} < T_{1,ref2}$ ), the temperature of the outer environment is categorized as "cold environment" and if the average temperature value of the outer environment ( $T_{avg}$ ) is detected to be less than the first first reference temperature value ( $T_{1,ref1}$ ) and greater than the second first temperature value ( $T_{1,ref2}$ ) ( $T_{1,ref2} < T_{avg} < T_{1,ref1}$ ), the temperature of the environment outside the body (2) is categorized as "medium temperature environment".

**[0024]** According to the present invention, in order to estimate the amount of load in the drum (3), the control unit is configured to determine a second reference temperature value ( $T_{2,ref}$ ) predetermined in relation to the temperature of the outer environment and saved by the producer based on the estimated temperature of the outer environment, to calculate the difference ( $\Delta T_{act}$ ) between the actual temperature of the air ( $T_{act1}$ ) detected by the temperature sensor (6) and said second reference temperature value ( $T_{2,ref}$ ), to compare the calculated difference ( $\Delta T_{act}$ ) with at least one threshold difference value ( $\Delta T_{ref1}$ ) predetermined and saved, and to categorize, based on the result of the comparison, the amount of load in the drum based on at least two predetermined categories. In this embodiment, if the calculated difference ( $\Delta T_{act}$ ) is greater than the threshold difference value ( $\Delta T_{ref1}$ ) ( $\Delta T_{act} > \Delta T_{ref1}$ ) after comparing the calculated difference ( $\Delta T_{act}$ ) and at least one predetermined and saved threshold difference value ( $\Delta T_{ref1}$ ), the load in the drum (3) is categorized as "low load", and if the calculated difference ( $\Delta T_{act}$ ) is less than the threshold difference value ( $\Delta T_{ref1}$ ) ( $\Delta T_{act} < \Delta T_{ref1}$ ), the load in the drum (3) is categorized as "full load".

**[0025]** According to the present invention, in order to estimate the load level in the drum (3), the control unit is configured to compare the difference ( $\Delta T_{act}$ ) between the actual temperature ( $T_{act1}$ ) of the air exiting the drum (3)

detected by the temperature sensor (6) and said second reference temperature value ( $T_{2,ref}$ ) with two different threshold difference values ( $\Delta T_{ref1}$ ,  $\Delta T_{ref2}$ ). In an exemplary embodiment wherein the first threshold difference value ( $\Delta T_{ref1}$ ) is greater than the second threshold difference value ( $\Delta T_{ref2}$ ) ( $\Delta T_{ref1} > \Delta T_{ref2}$ ), if the calculated difference ( $\Delta T_{act}$ ) is greater than the first threshold difference value ( $\Delta T_{ref1}$ ) ( $\Delta T_{act} > \Delta T_{ref1}$ ) after comparing the difference ( $\Delta T_{act}$ ) calculated with two threshold difference values ( $\Delta T_{ref1}$ ,  $\Delta T_{ref2}$ ) predetermined and saved, the control unit categorizes the amount of load in the drum (3) for example as "low load", and if the calculated difference ( $\Delta T_{act}$ ) is less than the second threshold difference value ( $\Delta T_{ref2}$ ) ( $\Delta T_{act} < \Delta T_{ref2}$ ), categorizes the amount of load in the drum for example as "full load", and if the calculated difference ( $\Delta T_{act}$ ) is less than the first threshold difference value ( $\Delta T_{ref1}$ ) and greater than the second threshold difference value ( $\Delta T_{ref2}$ ) ( $\Delta T_{ref1} < \Delta T_{act} < \Delta T_{ref2}$ ), categorizes the amount of load in the drum for example as "medium load".

**[0026]** By means of the present invention, by estimating the temperature of the environment the laundry drying machine (1) is placed and the load level in the drum (3) using at least the temperature value of the drying air exiting the drum (3) by means of the temperature sensor (6), the control unit enables the drying process to be performed in a controlled manner at least based on the temperature of the environment and the amount of load and thus, enables the laundry to be dried homogeneously.

## Claims

1. A laundry drying machine (1) **comprising** a body (2); a drum (3) which is positioned in the body (2), which has at least one air inlet opening and an air outlet opening and wherein the drying process is realized; at least one fan (4) which sucks air from the outer environment and directs the same towards the drum (3); at least one heater (5) for heating the ambient air which is sucked before entering the drum (3); a temperature sensor (6) which is configured to detect the temperature of the air exiting the drum (3); and at least one air outlet (7) which enables the air exiting the drum (3) to be discharged from the body (2), at least one control unit which is connected to the temperature sensor (6) so as to be in data communication with the same and which is configured to estimate the temperature level of the environment outside the body (2) and the load level in the drum (3) using at least the temperature value detected by the temperature sensor (6), and enable the drying process to be realized based on the estimated temperature level of the environment outside the body (2) and the estimated load level in the drum (3) **characterized by** the control unit which is configured to check if the temperature of the air exiting the drum (3) detected by the temperature sensor (6) reaches

- a target temperature value ( $T_2$ ) predetermined based on the temperature level of the outer environment and the load level in the drum (3) after estimating the temperature level of the outer environment and the load level in the drum and to finalize the drying process if, after the control process, it is detected that said target temperature value ( $T_2$ ) is reached and the control unit which is configured, in order to estimate the amount of load in the drum (3), to determine a second reference temperature value ( $T_{2,ref}$ ) predetermined in relation to the temperature of the outer environment and saved by the producer based on the estimated temperature of the outer environment, to calculate the difference ( $\Delta T_{act}$ ) between the actual temperature of the air ( $T_{act1}$ ) detected by the temperature sensor (6) and said second reference temperature value ( $T_{2,ref}$ ), to compare the calculated difference ( $\Delta T_{act}$ ) with at least one threshold difference value ( $\Delta T_{ref1}$ ) predetermined and saved, and to categorize, based on the result of the comparison, the amount of load in the drum based on at least two predetermined categories and wherein the control unit which is configured, in order to estimate the load level in the drum (3), to compare the difference ( $\Delta T^{act}$ ) between the actual temperature ( $T_{act1}$ ) of the air exiting the drum (3) detected by the temperature sensor (6) and said second reference temperature value ( $T_{2,ref}$ ) with two different threshold difference values ( $\Delta T_{ref1}$ ,  $\Delta T_{ref2}$ ).
2. A laundry drying machine (1) as in Claim 1, **characterized by** the control unit which is configured to check if the temperature of the air exiting the drum (3) detected by the temperature sensor (6) has reached a threshold temperature value ( $T_2$ ) predetermined based on the temperature level of the outer environment and the load level in the drum after estimating the temperature level of the outer environment and the load level in the drum (3) and if, after the control process, it is detected that said threshold temperature value ( $T_2$ ) is reached, to finalize the drying process at the end of a specific time period after the threshold temperature value ( $T_2$ ) is reached, wherein said time period is selected from a plurality of time period values predetermined and saved based on at least the outer environment temperature level and the load level and corresponds to the detected outer environment temperature level and the load level in the drum (3).
3. A laundry drying machine (1) as in any one of the above claims, **characterized by** the control unit which is configured, in order to estimate the temperature level of the environment outside the body (2), to calculate the average temperature ( $T_{avg}$ ) of the air taken from the outer environment for a specific amount of time before the heater (5) is activated, compare the average temperature ( $T_{avg}$ ) of the outer environment with at least one first reference temperature value ( $T_{1,ref1}$ ) predetermined and saved by the producer, and to select, based on the result of the comparison, the corresponding outer environment temperature category among at least two predetermined categories.
4. A laundry drying machine (1) as in Claim 3, **characterized by** the control unit which is configured to compare the calculated average temperature value of the outer environment ( $T_{avg}$ ) with two different first reference temperature values ( $T_{1,ref1}$ ,  $T_{1,ref2}$ ) in order to estimate the temperature level of the environment outside the body (2).

#### Patentansprüche

1. Ein Wäschetrockner (1), **umfasst** einen Körper (2); eine Trommel (3), die im Körper (2) positioniert ist, die mindestens eine Lufteinlassöffnung und eine Luftauslassöffnung aufweist und in der der Trocknungsprozess durchgeführt wird, mindestens einen Ventilator (4), der Luft aus der Außenumgebung ansaugt und diese in Richtung der Trommel (3) leitet; mindestens einen Heizer (5) zum Erwärmen der angesaugten Umgebungsluft vor dem Eintritt in die Trommel (3); einen Temperatursensor (6), der so konfiguriert ist, dass er die Temperatur der aus der Trommel (3) austretenden Luft erfasst; und mindestens einen Luftauslass (7), der das Abführen der aus der Trommel (3) austretenden Luft aus dem Körper (2) ermöglicht, mindestens eine Steuereinheit, die mit dem Temperatursensor (6) verbunden ist, um mit diesem in Datenkommunikation zu stehen, und die dazu konfiguriert ist, das Temperaturniveau der Umgebung außerhalb des Körpers (2) und das Ladungsniveau in der Trommel (3) abzuschätzen, unter Verwendung mindestens des vom Temperatursensor (6) erfassten Temperaturwerts und ermöglichen die Durchführung des Trocknungsprozesses auf der Grundlage des geschätzten Temperaturniveaus der Umgebung außerhalb des Körpers (2) und des geschätzten Beladungsgrads in der Trommel (3), **gekennzeichnet ist er dadurch**, dass die Steuereinheit so konfiguriert ist, dass sie prüft, ob die Temperatur der aus der Trommel (3) austretenden Luft, die von dem Temperatursensor (6) erfasst wird, einen Zieltemperaturwert ( $T_2$ ) erreicht, der auf der Grundlage des Temperaturniveaus der äußeren Umgebung und des Beladungsniveaus in der Trommel (3) nach dem Schätzen des Temperaturniveaus der äußeren Umgebung und des Beladungsniveaus in der Trommel vorgegeben ist, und dass sie den Trocknungsprozess beendet, wenn, nach dem Kontrollprozess festgestellt wird, dass der besagte Zieltemperaturwert ( $T_2$ ) erreicht ist, und die Kontrolleinheit, die konfiguriert ist, um die Beladungsmenge in

- der Trommel (3) zu schätzen, einen zweiten Referenztemperaturwert ( $T_{2,ref}$ ) zu bestimmen, der in Bezug auf die Temperatur der äußeren Umgebung vorbestimmt ist und vom Hersteller auf der Grundlage der geschätzten Temperatur der äußeren Umgebung gespeichert wird, die Differenz ( $\Delta T_{act}$ ) zwischen der tatsächlichen Temperatur der Luft ( $T_{act1}$ ), die von dem Temperatursensor (6) erfasst wird, und dem zweiten Referenztemperaturwert ( $T_{2,ref}$ ) zu berechnen, die berechnete Differenz ( $\Delta T_{act}$ ) mit mindestens einem Schwellendifferenzwert ( $\Delta T_{ref1}$ ) zu vergleichen, der vorher festgelegt und gespeichert wurde, und zu kategorisieren, auf der Grundlage des Ergebnisses des Vergleichs die Menge der Ladung in der Trommel auf der Grundlage von mindestens zwei vorbestimmten Kategorien zu kategorisieren, und wobei die Steuereinheit, die konfiguriert ist, um das Ladungsniveau in der Trommel (3) abzuschätzen, die Differenz ( $\Delta T_{act}$ ) zwischen der Ist-Temperatur ( $T_{act1}$ ) der aus der Trommel (3) austretenden Luft, die von der Temperaturmeseinrichtung ( $T_{2,ref}$ ) erfasst wird, und der Ist-Temperatur ( $T_{2,ref}$ ) zu vergleichen.
2. Ein Wäschetrockner (1), wie in Anspruch 1 aufgeführt, **ist dadurch gekennzeichnet, dass** die Steuereinheit so konfiguriert ist, dass sie prüft, ob die Temperatur der aus der Trommel (3) austretenden Luft, die von dem Temperatursensor (6) erfasst wird, einen Temperaturschwellenwert ( $T_{2'}$ ) erreicht hat, der auf der Grundlage des Temperaturniveaus der äußeren Umgebung und des Beladungsniveaus in der Trommel nach dem Schätzen des Temperaturniveaus der äußeren Umgebung und des Beladungsniveaus in der Trommel (3) vorgegeben ist, und wenn nach dem Kontrollprozess festgestellt wird, dass der Schwellentemperaturwert ( $T_{2'}$ ) erreicht ist, den Trocknungsprozess am Ende einer bestimmten Zeitspanne nach Erreichen des Schwellentemperaturwerts ( $T_{2'}$ ) zu beenden, wobei die Zeitspanne aus einer Vielzahl von Zeitspannenwerten ausgewählt wird, die auf der Grundlage zumindest des äußeren Umgebungstemperaturniveaus und des Beladungsniveaus vorbestimmt und gespeichert werden, und dem festgestellten äußeren Umgebungstemperaturniveau und dem Beladungsniveau in der Trommel (3) entspricht.
3. Ein Wäschetrockner (1), wie in einem der vorherigen Ansprüchen aufgeführt, **ist dadurch gekennzeichnet, dass** die Steuereinheit konfiguriert ist, um das Temperaturniveau der Umgebung außerhalb des Körpers (2) abzuschätzen, die durchschnittliche Temperatur ( $T_{avg}$ ) der Luft zu berechnen, die der äußeren Umgebung für eine bestimmte Zeitspanne entnommen wird, bevor der Heizer (5) aktiviert wird, die durchschnittliche Temperatur ( $T_{avg}$ ) der äußeren Umgebung mit mindestens einem ersten Referenztemperaturwert ( $T_{1,ref1}$ ) zu vergleichen, der durch den Hersteller vorbestimmt und gespeichert wird, und auf der Grundlage des Ergebnisses des Vergleichs die entsprechende Temperaturkategorie der äußeren Umgebung unter mindestens zwei vorbestimmten Kategorien auszuwählen.
4. Ein Wäschetrockner (1), wie in Anspruch 3 aufgeführt, **ist dadurch gekennzeichnet, dass** die Steuereinheit so konfiguriert ist, dass sie den berechneten durchschnittlichen Temperaturwert der äußeren Umgebung ( $T_{avg}$ ) mit zwei verschiedenen ersten Referenztemperaturwerten ( $T_{1,ref1}$ ,  $T_{1,ref2}$ ) vergleicht, um das Temperaturniveau der Umgebung außerhalb des Körpers (2) zu schätzen.

#### Revendications

1. Une machine de séchage du linge (1) **comprenant** un corps (2) ; un tambour (3) qui est positionné dans le corps (2), qui a au moins une ouverture d'entrée d'air et une ouverture de sortie d'air et dans lequel le processus de séchage est réalisé ; au moins un ventilateur (4) qui aspire l'air de l'environnement extérieur et le dirige vers le tambour (3) ; au moins un dispositif de chauffage (5) pour chauffer l'air ambiant qui est aspiré avant d'entrer dans le tambour (3) ; un capteur de température (6) qui est configuré pour détecter la température de l'air qui sort du tambour (3) ; et au moins une sortie d'air (7) qui permet à l'air sortant du tambour (3) d'être évacué du corps (2), au moins une unité de commande qui est connectée au capteur de température (6) de manière à être en communication de données avec lui et qui est configurée pour estimer le niveau de température de l'environnement à l'extérieur du corps (2) et le niveau de charge dans le tambour (3) en utilisant au moins la valeur de température détectée par le capteur de température (6), et permettre au processus de séchage d'être réalisé sur la base du niveau de température estimé de l'environnement extérieur du corps (2) et du niveau de charge estimé dans le tambour (3) **caractérisé par** l'unité de contrôle qui est configurée pour vérifier si la température de l'air sortant du tambour (3) détectée par le capteur de température (6) atteint une valeur de température cible ( $T_2$ ) prédéterminée sur la base du niveau de température de l'environnement extérieur et du niveau de charge dans le tambour (3) après avoir estimé le niveau de température de l'environnement extérieur et le niveau de charge dans le tambour et pour finaliser le processus de séchage si, après le processus de contrôle, il est détecté que ladite valeur de température cible ( $T_2$ ) est atteinte et l'unité de contrôle qui est configurée, afin d'estimer la quantité de charge dans le tambour (3), pour déterminer une deuxième valeur de température de référence ( $T_{2,ref}$ ) pré-

- déterminée par rapport à la température de l'environnement extérieur et sauvegardée par le producteur sur la base de la température estimée de l'environnement extérieur, pour calculer la différence ( $\Delta T_{act}$ ) entre la température réelle de l'air ( $\Delta T_{act1}$ ) détectée par le capteur de température (6) et ladite deuxième valeur de température de référence ( $T_{2,ref}$ ), comparer la différence calculée ( $\Delta T_{act}$ ) avec au moins une valeur seuil de différence ( $\Delta T_{ref1}$ ) prédéterminée et enregistrée, et classer, sur la base du résultat de la comparaison, la quantité de charge dans le tambour en fonction d'au moins deux catégories prédéterminées et dans lequel l'unité de commande qui est configurée pour estimer le niveau de charge dans le tambour ( $\Delta T_{ref1}$ ) peut être utilisée pour calculer le niveau de charge dans le tambour ( $\Delta T_{ref1}$ ), pour estimer le niveau de charge dans le tambour (3), à comparer la différence ( $\Delta T_{act}$ ) entre la température réelle ( $T_{act1}$ ) de l'air sortant du tambour (3) détectée par le capteur de température (6) et ladite deuxième valeur de température de référence ( $T_{2,ref}$ ) avec deux valeurs de différence de seuil différentes ( $\Delta T_{ref1}$ ,  $\Delta T_{ref2}$ ).
2. Une machine de séchage du linge (1) selon la déclaration 1, **caractérisée par** l'unité de commande qui est configurée pour vérifier si la température de l'air sortant du tambour (3) détectée par le capteur de température (6) a atteint une valeur de température seuil ( $T_2$ ) prédéterminée en fonction du niveau de température de l'environnement extérieur et du niveau de charge dans le tambour après avoir estimé le niveau de température de l'environnement extérieur et le niveau de charge dans le tambour (3) et si, après le processus de contrôle, il est détecté que ladite valeur de température seuil ( $T_2$ ) est atteinte, pour finaliser le processus de séchage à la fin d'une période de temps spécifique après que la valeur de température seuil ( $T_2$ ) est atteinte, dans laquelle ladite période de temps est sélectionnée parmi une pluralité de valeurs de période de temps prédéterminées et sauvegardées sur la base au moins du niveau de température de l'environnement extérieur et du niveau de charge et correspond au niveau de température de l'environnement extérieur détecté et au niveau de charge dans le tambour (3).
3. Une machine de séchage du linge (1) selon l'une quelconque des déclarations précédentes, **caractérisée par** l'unité de commande qui est configurée, pour estimer le niveau de température de l'environnement extérieur à la caisse (2), pour calculer la température moyenne ( $T_{avg}$ ) de l'air prélevé dans l'environnement extérieur pendant un laps de temps déterminé avant l'activation du dispositif de chauffage (5), comparer la température moyenne ( $T_{avg}$ ) de l'environnement extérieur avec au moins une première valeur de température de référence ( $T_{1,ref1}$ ) prédé-
- terminée et enregistrée par le producteur, et sélectionner, sur la base du résultat de la comparaison, la catégorie de température de l'environnement extérieur correspondante parmi au moins deux catégories prédéterminées.
4. Une machine de séchage du linge (1) selon la déclaration 3, **caractérisée par** l'unité de commande qui est configurée pour comparer la valeur de température moyenne calculée de l'environnement extérieur ( $T_{avg}$ ) avec deux premières valeurs de température de référence différentes ( $T_{u,ref1}$ ,  $T_{1,ref2}$ ) afin d'estimer le niveau de température de l'environnement à l'extérieur du corps (2).

Figure 1

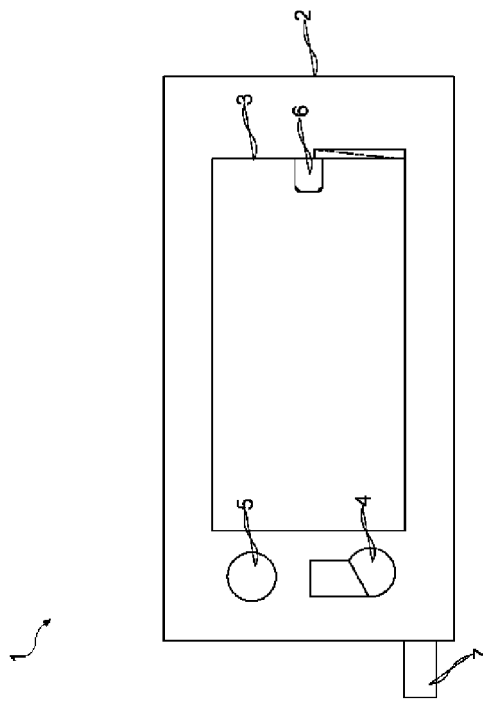

**REFERENCES CITED IN THE DESCRIPTION**

*This list of references cited by the applicant is for the reader's convenience only. It does not form part of the European patent document. Even though great care has been taken in compiling the references, errors or omissions cannot be excluded and the EPO disclaims all liability in this regard.*

**Patent documents cited in the description**

- EP 2034086 A [0004]
- US 10151061 B1 [0005]