

No. 606,877.

Patented July 5, 1898.

J. R. REYNOLDS.
SPEED LIMIT FOR ENGINES.

(Application filed Mar. 9, 1893.)

(No Model.)

2 Sheets—Sheet 1.

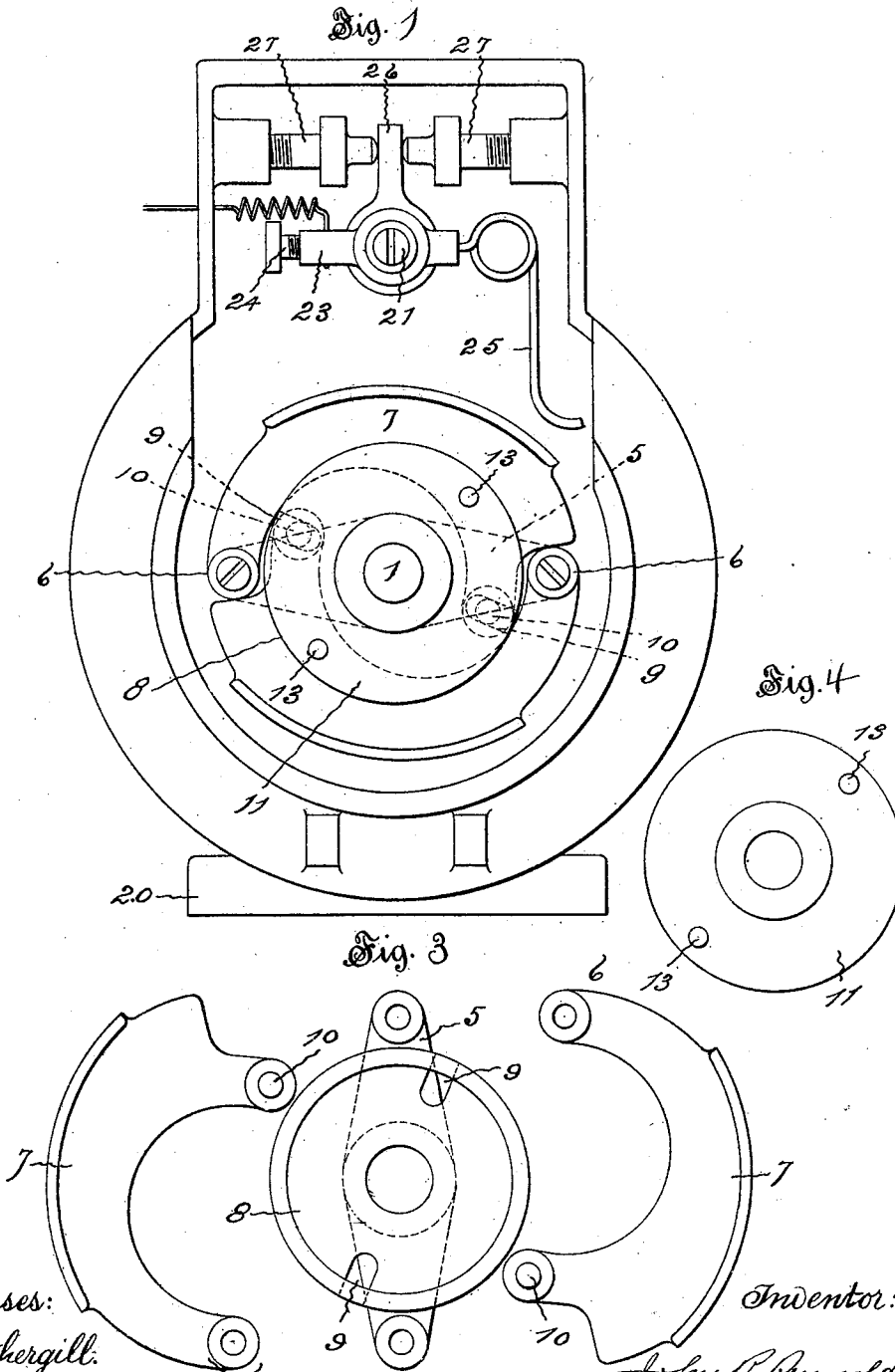

Witnesses:
E. W. Fothergill.
E. J. Hyde.

Inventor:
John R. Reynolds,
att.
Harry W. Williams,
att.

No. 606,877.

Patented July 5, 1898.

J. R. REYNOLDS.
SPEED LIMIT FOR ENGINES.

(Application filed Mar. 9, 1898.)

(No Model.)

2 Sheets—Sheet 2.

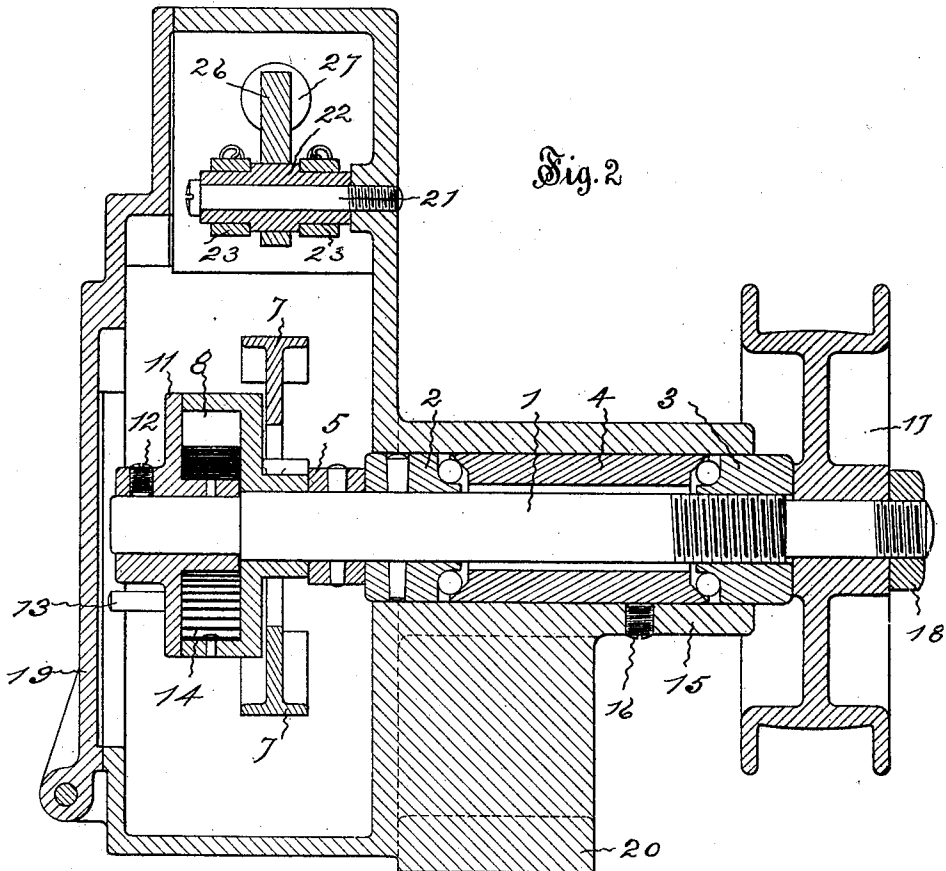

Fig. 2

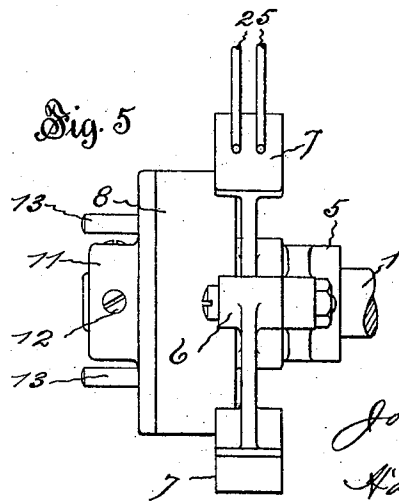

Fig. 5

Witnesses:

E. W. Fothergill.

E. J. Hyde.

Inventor:

John R. Reynolds
by
Harry P. Williams
att.

UNITED STATES PATENT OFFICE.

JOHN R. REYNOLDS, OF HARTFORD, CONNECTICUT.

SPEED-LIMIT FOR ENGINES.

SPECIFICATION forming part of Letters Patent No. 606,877, dated July 5, 1898.

Application filed March 9, 1898. Serial No. 673,217. (No model.)

To all whom it may concern:

Be it known that I, JOHN R. REYNOLDS, a citizen of the United States, residing at Hartford, in the county of Hartford and State of Connecticut, have invented certain new and useful Improvements in Speed-Limits for Engines, of which the following is a specification.

This invention relates to those devices which are employed for automatically actuating engine-stopping mechanisms when the engine with which they are connected exceeds the desired rate of speed either as a result of accident or change of load.

The object of the present invention is to provide a speed-limit which can be manufactured and assembled cheaply, which will be free running and durable, which shall be easy to connect and adjust, and which must be reliable and sensitive in action.

The embodiment of the invention illustrated by the accompanying drawings has a case having bearings which support a free-running spindle that is provided with means for connection with the shaft or other rotating part that is to be controlled and that is provided with weights which when the limit of speed is exceeded overcome a yielding connection between themselves and the spindle and make contact with the terminals of and close an electric circuit in which the stopping mechanism is connected.

Of the drawings, Figure 1 is a front elevation, with the cover removed, of this embodiment of the invention. Fig. 2 is a vertical section of the same, taken through the case and mechanisms longitudinally of the spindle. Fig. 3 is an enlarged disjointed view of the circuit-closing weights, the yoke that supports them, and the spring-barrel with which they engage. Fig. 4 is a view of the adjustable head of the spring-barrel; and Fig. 5 is a side elevation of the weights, yoke, spring-barrel, and head.

Fixed to the spindle 1 is a ball-cone 2, and adjustable on the spindle is a ball-cone 3. Between these cones and resting upon interposed balls is a sleeve 4. Near the fixed cone a yoke 5 is fastened to the spindle, and pivoted to the ends of this yoke are the ends 6 of the centrifugal wings or weights 7. Loosely mounted on the spindle is a spring-barrel 8.

This spring-barrel is provided with slots 9, and in these slots extend the pins 10, which project from the weights 7. The head 11 of the spring-barrel is adjustably connected with the spindle by means of a set-screw 12. This head is preferably provided with pins 13, by means of which it may be turned when the set-screw is loose. A spring 14 is placed in the barrel and one end connected with the hub of the head and the other end connected with the wall of the barrel. The spring is so wound and so holds the barrel that the weights, through the pins that engage the slots in the walls of the barrel, are pulled inwardly and restrained by yielding force. When the set-screw is loosened, the head may be rotated in such a direction that this tension of the spring can be accurately adjusted. With the parts arranged in this manner the spindle is thrust through the circular opening through the hub 15 at the back of the case. The sleeve is then secured in position by a set-screw 16, and this holds all of the parts in position. When the set-screw is again loosened; these parts can be withdrawn together from the case. After these parts have been placed in position a pulley 17 may be put on the spindle and secured by a nut 18. The pulley and nut arranged in this manner form a lock for the adjustable ball-cone. Of course the spindle and its bearings, with the pulley in place, can be inserted in the hub of the case before the weights and the yielding connections are placed on the spindle, if it is desired, and then the weights and connections may be located after the spindle is in place.

The case is shaped to properly inclose the mechanisms and is provided with a cover 19, that may be opened for inspecting or removing the mechanisms, and with a suitable base 20, whereby it may be secured in the desired location.

In the case, mounted loosely on a stud 21, is an insulating-bushing 22, and attached to this bushing are posts 23. Each of these posts has at one end a binding-screw 24 for the connection of an end of the circuit-wire and at the other end a spring-finger 25, of conducting material, that is arranged to project into the plane of rotation of the weights. The bushing has an arm 26, that extends be-

tween the ends of adjusting-screws 27. By properly turning these screws the arm may be moved in either direction, and this so rotates the bushing that the conducting-fingers, which are the terminals of the electric circuit, may be adjusted nearer to or farther from the peripheries of the weights borne by the spindle.

The device is located in position and the pulley belted to any shaft or other revolving part of an engine or connection of an engine which is to be the measure of the speed of rotation.

With the engine running at normal speed the weights are not thrown out by centrifugal action far enough to make contact with the terminal fingers of the circuit, but should the engine for any cause race or run faster than the desired normal the increased revolution of the spindle would throw the weights outwardly against the action of the spring in the spring-barrel sufficiently to cause their peripheries, which are formed of conducting material, to make contact with the fingers and close the electric circuit. When the circuit is closed, the engine-stop is set in operation and the engine shut down.

This invention is not limited to the use of oscillating weights. The weights may be connected with the yoke and shaft, so as to move outwardly in radial lines under centrifugal action without departing from the invention or causing any change in the mechanism which cannot be accomplished by the ordinary mechanic, and of course the device can be made to operate with one weight instead of two, if desired, without departing from the invention.

By simply turning the head of the spring-barrel the tension of the spring can be adjusted to the exact degree to insure the proper outward movement of the weights. The adjusting of the terminal fingers insures correct contact with the peripheries of the weights, the turning of the ball-cone adjusts the bearings to a nicety, and the securing in position of the pulley locks the bearings adjusted. When the cover is opened and the pulley removed, the parts and the bearings can be drawn out for inspection or renewal. As there is but little power required to operate this device and as the parts run freely, it will be very durable, and as the various elements can be accurately adjusted for the work required the device will be sensitive and reliable.

I claim as my invention—

1. In a speed-limit, in combination, a case, a rotary spindle, means for connecting the spindle with a rotating part, a helical spring connected with the spindle, weights loosely connected with the spindle so as to rotate therewith and held from outward movement by the spring, and electric-circuit terminals that extend outside of the weights in the plane of revolution to which the weights will move under centrifugal influence when the spindle

rotates more rapidly than normal, substantially as specified.

2. In a speed-limit, in combination, a case, a rotary spindle, means for connecting the spindle with a rotating part, a spring adjustably connected with the spindle, weights loosely connected with the spring and with the spindle so as to rotate therewith, and electric-circuit terminals that extend outside of the weights in the plane of revolution into which the weights will move under centrifugal influence when the spindle rotates more rapidly than normal, substantially as specified.

3. In a speed-limit, in combination, a case, a rotary spindle, means for connecting the spindle with a rotating part, weights pivotally connected with the spindle so as to rotate therewith, a spring connected with the spindle, a connection between the free ends of the weights and the spring and electric-circuit terminals that extend outside of the weights in the plane of revolution into which the weights will move under centrifugal influence when the spindle rotates more rapidly than normal, substantially as specified.

4. In a speed-limit, in combination, a case, a rotary spindle, means for connecting the spindle with a rotating part, weights pivotally connected with the spindle, a spring-barrel and a head borne by the spindle, one part being loosely connected with the spindle and the other part being free on the spindle, a spring with one end connected with the barrel and the other end connected with the head, weights loosely connected with the spindle and loosely connected with the loose part to which the spring is attached, and electric-circuit terminals that extend outside of the weights in the plane of revolution into which the weights will move under centrifugal influence when the spindle rotates more rapidly than normal, substantially as specified.

5. In a speed-limit, in combination, a case, a rotary spindle, means for connecting the spindle with a rotating part, a yoke secured to the spindle, weights pivoted to the yoke, a spring-barrel loosely mounted on the spindle, a barrel-head fixed to the spindle, a spring with one end connected with the barrel and the other end connected with the head, a loose connection between the weights and the spring-barrel, and electric-circuit terminals that extend outside of the weights in the plane of revolution into which the weights will move under centrifugal influence when the spindle rotates more rapidly than normal, substantially as specified.

6. In a speed-limit, in combination, a case, a bearing-sleeve removably supported by the case, a rotary spindle adjustably supported upon bearings retained by the bearing-sleeve, means for connecting the spindle with a rotating part, weights loosely connected with the spindle, a spring connected with the spindle, a connection between the spring and the weights, and electric-circuit terminals that

5 extend outside of the weights in the plane of
revolution into which the weights will move
under centrifugal influence when the spindle
rotates more rapidly than normal, substan-
tially as specified.

10 7. In a speed-limit, in combination, a case,
a sleeve in the case, a rotary spindle provided
with a fixed and an adjustable ball-cone ar-
ranged to be supported by balls between the
15 cones and the sleeve, means for connecting
the spindle with a rotating part, which means
are arranged to lock the adjustable ball-cone
in position, weights loosely connected with
the spindle, a spring connected with the spin-
20 dle, a connection between the weights and
the spring, and electric-circuit terminals that
extend outside of the weights in the plane of
revolution into which the weights will move
under centrifugal influence when the spindle

rotates more rapidly than normal, substan- 20
tially as specified.

8. In combination with the centrifugally-
acting weights of a speed-limit, a single heli-
cal spring for retaining the weights against
centrifugal movement, electric-circuit termi- 25
nals that extend outside of the weights in the
plane of revolution in which the weights will
move under centrifugal influence when the
spindle rotates more rapidly than normal,
means for connecting the circuit-wires with 30
the terminals, and adjustable means for ac-
curately locating the contact portions of the
terminals, substantially as specified.

JOHN R. REYNOLDS.

Witnesses:

H. R. WILLIAMS,
E. W. FOTHERGILL.