



INTERNATIONAL APPLICATION PUBLISHED UNDER THE PATENT COOPERATION TREATY (PCT)

<p>(51) International Patent Classification⁶ : G01N 21/35, 21/03, H01L 27/16, 35/32</p>	<p>A1</p>	<p>(11) International Publication Number: WO 99/41592 (43) International Publication Date: 19 August 1999 (19.08.99)</p>
<p>(21) International Application Number: PCT/SE99/00145 (22) International Filing Date: 4 February 1999 (04.02.99) (30) Priority Data: 9800462-5 17 February 1998 (17.02.98) SE (71)(72) Applicants and Inventors: MARTIN, Hans, Göran, Evald [SE/SE]; Östansjö 2837, S-820 60 Delsbo (SE). ÖHMAN, Per, Ove [SE/SE]; Asplunda, Uppsala-Näs, S-755 91 Uppsala (SE). (74) Agent: LINDBLÖM, Erik, J.; Flotthamn, S-150 23 Enhörna (SE).</p>	<p>(81) Designated States: AL, AM, AT, AT (Utility model), AU, AZ, BA, BB, BG, BR, BY, CA, CH, CN, CU, CZ, CZ (Utility model), DE, DE (Utility model), DK, DK (Utility model), EE, EE (Utility model), ES, FI, FI (Utility model), GB, GD, GE, GH, GM, HR, HU, ID, IL, IN, IS, JP, KE, KG, KP, KR, KZ, LC, LK, LR, LS, LT, LU, LV, MD, MG, MK, MN, MW, MX, NO, NZ, PL, PT, RO, RU, SD, SE, SG, SI, SK, SK (Utility model), SL, TJ, TM, TR, TT, UA, UG, US, UZ, VN, YU, ZW, ARIPO patent (GH, GM, KE, LS, MW, SD, SZ, UG, ZW), Eurasian patent (AM, AZ, BY, KG, KZ, MD, RU, TJ, TM), European patent (AT, BE, CH, CY, DE, DK, ES, FI, FR, GB, GR, IE, IT, LU, MC, NL, PT, SE), OAPI patent (BF, BJ, CF, CG, CI, CM, GA, GN, GW, ML, MR, NE, SN, TD, TG).</p> <p>Published <i>With international search report. Before the expiration of the time limit for amending the claims and to be republished in the event of the receipt of amendments.</i></p>	

(54) Title: A METHOD OF PRODUCING A DETECTOR BELONGING TO A GAS SENSOR, AND A DETECTOR PRODUCED IN ACCORDANCE WITH THE METHOD

(57) Abstract

The present invention relates to a method of producing a gas sensor co-acting detector intended for the detection of electromagnetic waves, such as infrared light rays, that pass through a gas cell. The gas cell (2) includes a cavity (21), which functions to enclose a gas volume (G) for measuring or evaluating purposes. The surface or parts of the surface forming walls within the gas cell or the cavity is/are coated with one or more different metal layers (M1, M2) with the intention of providing a highly reflective surface for reflection of said electromagnetic waves. The detector (3) is comprised of a thermal element and is formed on a base structure (31). That part of the base structure that shall form said detector is comprised of one or more topographically structured surface regions. At least said surface region or surface regions is/are coated with a first and a second electrically conductive metal layer (M1 and M2 respectively) which are intended to form said thermocouple. The first metal layer (M1) is applied at a first angle other than 90°, and the second metal layer (M2) is applied at a second angle which is also other than 90° and which differs from the first angle. The topographical structure and/or configuration including the thus coated electrically conductive layers provides the function of one or more thermocouples, by virtue of the first and the second metal layers (M1, M2) overlapping each other within discrete detector-associated surface parts.

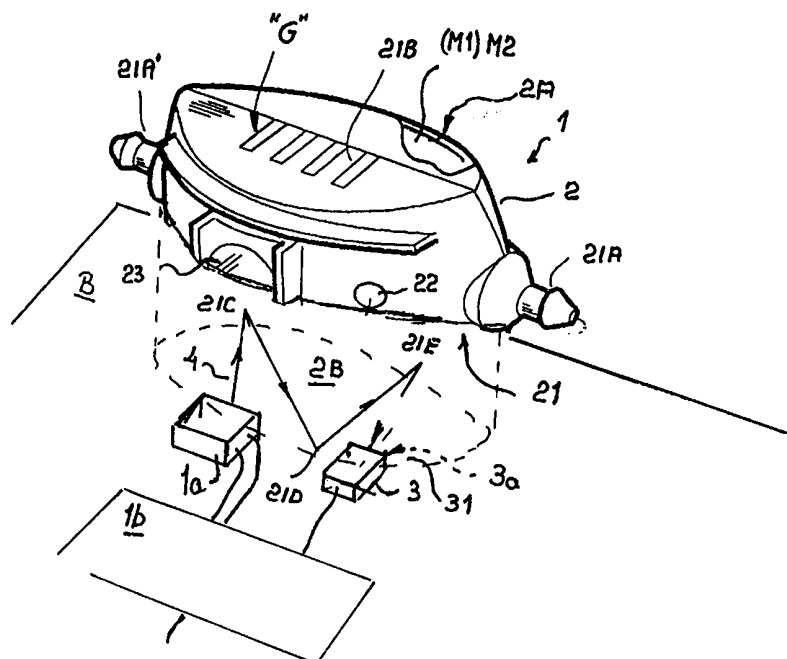

The topographical structure and/or configuration including the thus coated electrically conductive layers provides the function of one or more thermocouples, by virtue of the first and the second metal layers (M1, M2) overlapping each other within discrete detector-associated surface parts.

FOR THE PURPOSES OF INFORMATION ONLY

Codes used to identify States party to the PCT on the front pages of pamphlets publishing international applications under the PCT.

AL	Albania	ES	Spain	LS	Lesotho	SI	Slovenia
AM	Armenia	FI	Finland	LT	Lithuania	SK	Slovakia
AT	Austria	FR	France	LU	Luxembourg	SN	Senegal
AU	Australia	GA	Gabon	LV	Latvia	SZ	Swaziland
AZ	Azerbaijan	GB	United Kingdom	MC	Monaco	TD	Chad
BA	Bosnia and Herzegovina	GE	Georgia	MD	Republic of Moldova	TG	Togo
BB	Barbados	GH	Ghana	MG	Madagascar	TJ	Tajikistan
BE	Belgium	GN	Guinea	MK	The former Yugoslav Republic of Macedonia	TM	Turkmenistan
BF	Burkina Faso	GR	Greece			TR	Turkey
BG	Bulgaria	HU	Hungary	ML	Mali	TT	Trinidad and Tobago
BJ	Benin	IE	Ireland	MN	Mongolia	UA	Ukraine
BR	Brazil	IL	Israel	MR	Mauritania	UG	Uganda
BY	Belarus	IS	Iceland	MW	Malawi	US	United States of America
CA	Canada	IT	Italy	MX	Mexico	UZ	Uzbekistan
CF	Central African Republic	JP	Japan	NE	Niger	VN	Viet Nam
CG	Congo	KE	Kenya	NL	Netherlands	YU	Yugoslavia
CH	Switzerland	KG	Kyrgyzstan	NO	Norway	ZW	Zimbabwe
CI	Côte d'Ivoire	KP	Democratic People's Republic of Korea	NZ	New Zealand		
CM	Cameroon			PL	Poland		
CN	China	KR	Republic of Korea	PT	Portugal		
CU	Cuba	KZ	Kazakstan	RO	Romania		
CZ	Czech Republic	LC	Saint Lucia	RU	Russian Federation		
DE	Germany	LI	Liechtenstein	SD	Sudan		
DK	Denmark	LK	Sri Lanka	SE	Sweden		
EE	Estonia	LR	Liberia	SG	Singapore		

5

10 **TITLE OF INVENTION: A METHOD OF PRODUCING A DETECTOR
BELONGING TO A GAS SENSOR, AND A DETECTOR
PRODUCED IN ACCORDANCE WITH THE METHOD**

FIELD OF INVENTION

15

The present invention relates to a method of producing a detector which belongs to or is associated with a gas sensor and which is intended to detect electromagnetic waves, such as infrared light rays, passing through a gas cell.

20

Reference to a gas sensor in the following description implies a device which includes a gas cell having a cavity in which a gas volume to be evaluated is enclosed or is allowed to pass therethrough, a device that generates electromagnetic waves, such as a light source which is adapted to emit infrared light rays, a detector adapted to receive the electromagnetic waves generated by said light source subsequent to said rays having travelled along an adapted measuring path within the gas-cell cavity, and an electric or electronic circuit

25
30
35

coupled to the detector for evaluating the intensity of the electromagnetic waves entering the detector and/or to subject said electromagnetic waves to spectral analysis, and thereby determine the structure, concentration and/or the composition of said gas.

35

The invention is therewith based on the use of a gas cell that defines a cavity capable of enclosing a gas volume to be measured or evaluated, where the surface or parts of the surface of cavity-defining wall parts in the gas cell is/are
5 coated with one or more different metal layers with the intention of being able to form a surface which is highly reflective to electromagnetic waves.

More specifically, the present invention relates to a method
10 of producing a detector belonging to a gas sensor and having properties relating to the properties of thermocouples.

The present invention also relates to a detector produced in accordance with the method and adapted to co-act with a gas
15 cell, either directly or indirectly.

DESCRIPTION OF THE BACKGROUND ART

It has long been known to use electromagnetic waves in conjunction with absorption spectroscopy, and then particularly
20 light rays within the infrared range, and to use a temperature-sensitive thermal element as a detector, for instance a thermocouple or a number of thermocouples connected in series, where the thermoelectric effect between two different
25 metals is utilised to generate a voltage difference between a hot and a cold soldering point belonging to said thermocouple. The hot soldering point, or points, is/are placed so as to be exposed by the incident light rays, while corresponding cold solder points are positioned so as to be shadowed from
30 the incident light rays.

It is also known to use thermal elements in the form of Bolometers with which the electromagnetic waves received result in a change in resistance relative to a variation in temperature, and where a number of series-coupled resistance changes
35 are utilised to obtain accurate measuring results.

It is also known to construct gas sensors that are based on absorption techniques. In gas sensors of this nature, the light rays are allowed to pass through a gas sample contained
5 in the cavity of a gas cell, wherewith certain frequency-dependent quantities of the light rays are absorbed by the gas present in the cavity. In this case, a detector is adapted to detect the light rays, and the gas in the cavity, or the concentration of said gas, can be determined by evaluating
10 the intensity of the light rays detected in relation to the chosen intensity of the incident light rays and the absorption coefficient with respect to the light concerned, or the electromagnetic wavelength, in the gas in question.

15 It is also known to enable a gas cell to be compressed or made more compact with respect to its physical dimensions, by enabling the light rays to be reflected repeatedly within the cavity such as to obtain a relatively long measuring path (path length) or absorption path in relation to the internal
20 dimensions of the gas cell or the cavity.

Patent Publication US-A-5,009,493 illustrates an example of an absorption gas cell designed to provide an absorption path or measuring path of adapted length within a cavity in which
25 incoming light rays are reflected repeatedly within the cavity before being reflected out of said cavity and falling on a detector.

With gas cells of this nature, it is usual to allow incoming
30 light rays to pass into the cavity through a first opening and to be led out of the cavity through a second opening, wherewith the detector is comprised of a separate part which is preferably mounted on the gas cell in the close proximity of the second opening.

35

The gas cell cavity is normally formed with the aid of at least one first and one second part, whose inner surfaces can be treated individually to provide surfaces that will reflect the incoming light rays. These inner surfaces of the first and second parts are usually coated with one or more metal layers, wherewith the metal layer last applied forms reflecting surfaces or mirror surfaces. The metal used and the method of its application depends on the desired optical qualities of the surfaces and also on the optical wavelength or wavelengths the surfaces shall reflect. The choice of material in the actual body of the gas cell shall also be taken into account.

With respect to the general features of the present invention, it should also be mentioned that it is known to construct small mechanical structures by means of so-called micromechanical or microtechnological methods, where mechanical components are formed on and in a substrate, such as a silicon chip for instance, with the aid of different techniques.

The publication "Combustible Gas Sensor Produced With 3D-Micro Technology", by Tsing Cheng, Landis & Gyr Corporation, Central Research and Development Lab., CH-6301 Zug, Switzerland, illustrates how a compact three-dimensional thermopile can be formed by microtechnological methods.

The substrate used in this case is a silicon disc or chip coated with a layer of Si-nitride, which provides effective heat conductivity and effective electric insulation (Fig. 5a). A grating or a number of ridges is/are formed on this surface (Fig. 5b). The grating is coated with metal layers so as to form two different electrical conductors at two different oblique angles (Fig. 5c), therewith forming a plurality of mutually sequential junctions from the one conductor to the other. This results in a stack of thermocouples.

The publication also discloses the possibility of constructing the three-dimensional structure (Fig. 5b) from polyimide.

Also relevant in the present context is a paper published in conjunction with a national conference "Micro Structure Workshop 1996" held in Uppsala, Sweden, March 26-27, 1996, by Olle Larsson, Industrial Microelectronics Center (IMC), Stockholm, Sweden, entitled "Polymeric Microstructures and Replication Techniques", which describes how micromechanically produced models can be replicated by first producing a model that corresponds exactly to the desired copy or replica with the aid of a micromechanical process, and then producing from the model a mould which is complementary to said model and the desired copy or replica, and thereafter producing several copies or replicas with the aid of the mould. A number of ways of carrying out this procedure are described.

Prior publications "Photonics and the Environment", March 1996, illustrates and describes a detector in the form of a Bolometer, and prior publication 0-7803-4412-X/98 \$ 10.00 (c) 1998 IEEE describes "A Silicon IR-source and CO₂-Chamber for CO₂ Measurements". Both of these publications contribute towards a better understanding of the fundamental principles of the present invention.

25

SUMMARY OF THE INVENTION

TECHNICAL PROBLEMS

When taking into consideration the technical deliberations that a person skilled in this particular art must make in order to provide a solution to one or more technical problems that he/she encounters, it will be seen that on the one hand it is necessary initially to realise the measures and/or the sequence of measures that must be undertaken to this end, and on the other hand to realise which means is/are required to

35

solve one or more of said problems. On this basis, it will be evident that the technical problems listed below are highly relevant to the development of the present invention.

5 When considering the present state of the art as described above, it will be evident that with respect to a method of producing a detector which belongs to a gas sensor and which is intended to detect electromagnetic waves, such as infrared
10 light rays passing through a gas cell in which there is defined a cavity for enclosing a volume of gas to be measured or evaluated, where the surface or parts of the surface that forms/form the wall parts of the gas cell or of the cavity is/are coated with one or more layers of different metals with the intention of forming a surface that is highly re-
15 flective with respect to said electromagnetic waves, and where the detector is comprised of a thermal element, it will be seen that a problem resides in realising the measures that need to be taken to mass-produce such a detector in a simple and cost-effective manner, and also in realising how these
20 measures can be implemented.

Another technical problem is one of realising how a detector and the electrically conductive paths and/or other electric and/or electronic components belonging to said detector can
25 be produced within a limited surface region around or on a gas cell.

Another technical problem is one of realising how a topographic structure produced with high precision in, for instance, a silicon substrate either directly or through the
30 medium of complementary means and representing or corresponding to a detector and/or a conductor path and/or electric, and/or electronic components can be transferred to form in plastic material a topographical structure whilst retaining
35 the necessary precision, and then coating the topographical replica with one or more metal layers in a manner known per

se so as to form said detector and also, when required, conductor paths, electric and/or electronic components and circuits, and when applicable connection pads.

5 When a gas cell is comprised of a first and second parts that co-act mutually to form said cavity, another technical problem resides in realising those measures that are necessary to form a detector as an integral part of at least one of said gas-cell parts.

10

Another technical problem is one of realising how a detector that has the form of a thermal element and that has been produced in accordance with the present invention shall be positioned and how the topographical pattern shall be formed in
15 the plastic material and also of realising the conditions required to coat the topographical pattern with one or more metal layers and the type of metals that shall be chosen in respect of incident light rays so as to be able to expose solely the hot solder points or the like to irradiation by
20 the incident light rays and not the cold solder points or the like.

Another technical problem is one of realising what is required to insulate or isolate an integrated thermal element
25 on a reflective metal surface on an electrically insulated body or body part from the remainder of the reflective surface without needing to employ lithographic methods to this end.

30 Another technical problem is one of realising how different ridges belonging to the topographical pattern or three-dimensional structure can be readily positioned in relation to one another so as to provide a series-coupling of thermal elements that are orientated in rows and columns and there-
35 with provide a very compact detector surface that has a high

density of thermal elements, regardless of whether the thermal elements are thermocouples or Bolometers.

Another technical problem is one of realising how the columns
5 and/or rows of ridges shall be interconnected electrically
when so required, and electrically isolated from one another
when so required, by configuring the topographical structure
and by choosing the metal layers and the method of their ap-
plication in accordance herewith.

10 Another technical problem is one of realising how the topog-
raphical structure shall be formed within the gas cell so as
to provide the requisite connecting electrodes for an inte-
grated detector/gas cell, in addition to the thermal element.

15 Another technical problem is one of realising how the so-
called hot solder points or the like shall be adapted to ab-
sorb incident light rays, and to realise how the so-called
cold solder points or the like shall be adapted to reflect
20 incident light rays, if it should be that the cold solder
points or the like would be exposed to incident light rays.

A related technical problem in this regard, particularly when
a detector is adapted to detect infrared light rays, is one
25 of realising how the hot solder points or the like shall be
covered by a heat-absorbent layer and how the cold solder
points or the like shall be covered by a heat-reflecting
layer.

30 Still another technical problem is one of realising which
type of metals shall be used when coating, e.g., the inner
wall parts of the first cell-part so as to obtain the in-
tended reflection by said first cell-part and the intended
change in resistance or thermoelectric effect of the thermal
35 elements formed.

Another technical problem is one of realising the conditions required to adapt a gas cell so as to provide a plurality of different measurement paths.

5 With a starting point from an integrated detector/gas cell, another technical problem is one of realising the conditions necessary for mass-producing said integrated/gas cell in a simple and cost-effective manner.

10 With a starting point from an earlier known thermocouple-forming topographical structure, another technical problem is one of realising the conditions that are required for a similar topographical structure to form a part of the first cell-part, and also to realise the advantages that are afforded
15 hereby.

Another technical problem is one of realising the cost and production advantages that are afforded when one part of a two-part gas cell and a part of the detector surface-section
20 are produced by shaping the same, such as moulding, pressing or embossing, against a die or mould that has a topographical surface section complementary to the topography required for the thermal element, where at least that part of the die or
25 mould which corresponds to the detector is produced by electroplating or likewise treatment of a model of a surface section of the detector, where said model is produced by micro-mechanically working a substrate, such as a silicon substrate.

30 Another technical problem is one of realising the production advantages and cost advantages that are afforded by shaping, such as moulding, pressing or embossing, a part of a two-part gas cell and a part of a surface section of the detector
35 against a complementary model of the detector-associated surface section.

Another technical problem is one of realising the metrological advantages that are afforded by giving the topographical structure a square, or essentially square, extension.

5 It will be seen that in the case of a square extension, a technical problem is one of providing conditions which enable a plurality of columns of ridges with series-connected thermal elements to be interconnected to form a single series of interconnected thermal elements, particularly thermocouples.

10

In addition, a technical problem resides in realising the possibilities that are obtained when the detector is adapted to detect infrared light rays and which enables cold and hot solder points or the like to be adapted to absorb and reflect
15 heat respectively.

SOLUTION

With a starting point from a detector belonging to a gas sensor and intended for detecting electromagnetic waves, such as
20 infrared light rays, that pass through a gas cell which includes a cavity adapted for enclosing a volume of gas to be measured or evaluated, where the surface or parts of the surface that form wall parts within the gas cell or the cavity
25 is/are coated with one or more layers of different metals with the intention of forming a surface that is highly reflective to said electromagnetic waves, and wherein the detector is comprised of a thermal element, there is proposed in accordance with the present invention with the intention
30 of solving one or more of the aforesaid problems a method and a detector that are characterised in that the detector shall be formed on a base unit, that the part of the base unit that is intended to form the detector is comprised of one or more surface regions that is/are shaped to provide a topographical
35 structure, that at least this surface region or the surface regions is/are coated at least with a first electrically con-

ductive metal layer which is intended to form the thermal element via the topographical structure.

5 According to proposed embodiments that lie within the scope of the present invention, the thermal element may comprise a Bolometer or a row of thermocouples.

10 In this latter application, it is proposed that a first metal layer is applied at a first angle other than 90° , and that a second metal layer is applied at another angle other than 90° and different from said first angle, and that the topographical structure and/or said configuration including said electrically conductive coatings functions/function as one or more thermocouples by virtue of the first and the second
15 metal layer or coating overlapping each other within discrete surface parts of the detector.

20 According to one embodiment of the invention, the detector is produced on a limited surface region, and electrical conductor paths and/or electric circuits and/or electronic circuits are produced in the same way adjacent the limited surface region.

25 With the intention of enabling the topographical structure to be produced with sufficient precision, it is proposed in accordance with the invention that the base structure of the detector is produced by shaping, such as moulding, pressing or embossing, said base structure against a mould or die that has a complementary topographical structure, and that at
30 least one part of the die or mould, i.e. that part which corresponds to the surface section of said detector, is produced by electroplating or likewise treating a model that has a topographical configuration adapted for said detector, and that said model is produced by micromechanically working a substrate, such as a silicon substrate.
35

Alternatively, the topographical structure can be produced with sufficient precision by shaping, e.g. moulding, pressing or embossing, the base structure against a mould or die that has said complementary topographical structure, and by producing at least a part of said mould or die, i.e. that part which corresponds to the surface section of said detector, by micromechanically working a substrate, such as a silicon substrate.

10 In those instances when a gas cell is comprised of first and second parts that are able to form said cavity when appropriately brought together, it is proposed in accordance with the invention that the base structure is applied as a unit separate from the first cell part.

15 According to the present invention, it is particularly beneficial for the base structure to form an integral part of the first cell part, and for the detector-associated surface parts to form a part of the inner surface of said cavity.

20 In such cases, the cavity-associated surface sections can be coated at the same time as the detector-associated surface parts are coated, and with the same metal coatings.

25 According to one embodiment of the invention, the topographical structure may be adapted to provide requisite detector connection pads, and also electric conductor paths and/or electric circuits and/or electronic circuits.

30 Electric conductor paths and/or electric and/or electronic circuits may also be formed in the second cell part.

35 According to one embodiment of the invention, the topographical part of the detector may comprise a number of so-called conductive ridges that have a first side surface, a second side surface and an upper surface, and to provide a so-called

conductive surface in between respective mutually adjacent ridges.

5 According to the invention, the detector-associated base structure is coated with a layer of a first metal at a first angle relative to said base structure, and with a layer of a second metal at a second angle relative to said base structure, wherein the first angle is adapted so that the first side surface and at least a part of the upper surface of re-
10 spective conductive ridges and at least a part of the intermediate conductive surfaces will be coated with the layer of said first metal, and wherein said second angle is adapted so that the second side surface and at least a part of the upper surface of respective conductive ridges and at least a part
15 of the intermediate conductive surfaces will be coated with a layer of said second metal.

According to one embodiment, the first and the second angles are adapted relative to one another such that the layer of
20 said second metal will overlap and be in electrical contact with the layer of said first metal solely on the upper surface of respective conductive ridges and on the intermediate conductive surfaces, such that the metal layers will form a series of electrically interconnected junctions between the
25 first and the second metals.

It is also proposed in accordance with the present invention that the metal layers in the integrated part shall be electrically isolated from the metal layers within surrounding
30 surface sections of the base structure.

With the intention of enabling hot solder points to be exposed to incident light rays while excluding cold solder points from exposure of said rays, it is proposed in accordance with the invention that the detector-associated surface
35 parts are positioned relative to the incident light rays such

that said light rays will irradiate the upper surface of respective conductive ridges and such that said intermediate conductive surfaces will be shadowed by the conductive ridges with respect to said incident light rays.

5

Requisite electrical insulation, or isolation, between the conductive ridges and surrounding metal layers is achieved in accordance with the present invention with the aid of so-called insulating ridges that have associated so-called insulating surfaces that are positioned relative to one another and relative to said conductive ridges and also relative to said first and said second angle such that said insulating surfaces will be devoid of said first and said second metals.

10

15

With the intention of providing a series of thermocouples positioned in rows and columns, it is proposed in accordance with the invention that the conductive ridges will be given a configuration in which they form n-number of columns, these columns being designated column 1, column 2, etc., up to column "n", and where the number of conductive ridges in each column is "m", said columns being designated ridge 1, ridge 2 to ridge "m", where "m" may be different in respect of each column.

20

25

In order to enable the ridges of respective columns to be coupled together, it is proposed in accordance with the invention that the first ridge in each column, with the exception of the "n"th column, and the "m"th ridge in each column, with the exception of the last column, form interconnection ridges, where the "m"th ridge in each column, with the exception of the last column, is electrically connected together with the first ridge of the next following column, whereby the junctions between the first and the second metal layers of all conductive ridges within all columns form said series of electrically interconnected junctions.

30

35

Thus, the junctions between the first and second metal layers of all conductive ridges in all columns will form a common series of electrically interconnected junctions.

5 According to the present invention, the electrical interconnection between an "m"th ridge in one column and a first ridge in an adjacent column is achieved by virtue of forming an electrically conductive surface section between the adjacent columns and connecting this conductive surface section
10 to mutually interconnected ridges of adjacent columns while electrically insulating or isolating said conductive surface section from said adjacent columns in other respects.

With the intention of providing connection electrodes for the
15 thus formed thermocouple, it is proposed in accordance with the invention that the aforesaid series of conductive ridges form the series-connected thermocouple, that the metal coating or layer on a first or a second side surface of a first
20 conductive ridge, or a conductive surface adjacent said first conductive ridge in said series of conductive ridges, forms a first connection electrode on the thermocouple, and that a first or a second side surface of a last conductive ridge, or an adjacent conductive surface of said last conductive ridge
25 in said series of conductive ridges forms a second connection electrode on said thermocouple.

When the light rays are rays that lie in the infrared wavelength range and when the detector is adapted to detect infrared light, it is proposed in accordance with the present
30 invention that the upper surface of respective conductive ridges is covered with a heat-absorbent layer and that the intermediate conductive surfaces are covered with a heat-reflecting layer.

35 More specifically, it is proposed in accordance with the present invention that the heat-absorbent layer is comprised of

carbon and that the heat-reflecting layer is formed by the metal layers existing thereon.

5 In order to limit the amount of light that is reflected down between two adjacent ridges it is proposed that these are positioned relative to incident light rays so that the metal with the lowest reflection coefficient of the two reflection coefficients is the metal covering the side surface of the ridges that will face the incident light rays.

10

In order to achieve a good thermoelectric effect in the junction of the metal chosen for the first metal layer to the metal chosen for the second metal layer, the first metal shall differ from the second metal. It is also proposed in accordance with the invention that the two metals are gold covering chromium, which together provide both a thermoelectric effect and suitable optical properties in connecting with the reflecting surface to be formed within the cavity.

15

20 With the intention of providing the possibility of utilising different measuring paths inside the cavity, it is proposed in accordance with the present invention that the first cell part can be provided with two or more different detectors, and that the second cell part can be provided with one or more detectors.

25

The present invention also relates to a detector that has the properties possessed by a detector produced in accordance with the aforementioned method. The method and a gas sensor constructed in accordance with the method offer a solution to all of the technical problems recited in the introduction.

30

ADVANTAGES

35 Those advantages primarily afforded by an inventive method and a detector constructed in accordance with said method re-

side in the ability of producing a detector for co-action with a gas sensor in a simple and cost-effective manner and being adapted particularly with regard to concepts of the invention.

5

According to the invention, a detector that includes a very large number of series-connected thermal elements can be produced in large volumes and with great precision. This enables detectors integrated in a gas cell to be mass-produced, said
10 detector being highly sensitive as a result of the large number of series-connected thermal elements and being optically well aligned in the measuring path.

The necessary detector model is produced with high precision
15 by micromechanically working, e.g., a silicon base structure and the model transferred to a die or mould used in the mass production of gas cell base structures, for instance in a plastic material.

20 The advantages afforded by a method and/or a detector according to the present invention are applicable with respect to production, enabled by simple high precision manufacture, and with regard to cost by enabling the mass production of sensitive and effectively aligned detectors that are especially
25 adapted with respect to their application.

The primary characteristic features of an inventive method
30 are set forth in the characterising clause of the following Claim 1, while the primary characteristic features of an inventive detector are set forth in the characterising clause of the following Claim 26.

35

BRIEF DESCRIPTION OF THE DRAWINGS

A method and a gas sensor having features characteristic of the present invention will now be described in more detail by way of example, with reference to the accompanying drawings, in which

Figure 1 is a highly simplified, schematic illustration of a gas sensor built-up on a plate or base structure and including a two-part gas cell whose one part is shown over the bottom part on which a detector and a light generating device are fastened and which is adapted according to the specifications given in accordance with the present invention in other respects;

Figure 2 is a schematic, side view of a portion of a first cell part according to Figure 1;

Figure 3 is a schematic, somewhat enlarged side view of an inventive detector;

Figure 4 illustrates a detector according to Figure 3 that includes two layers of different metals which form a number of series-connected thermal elements in the form of thermocouples;

Figure 5 is a highly simplified and schematic illustration of a possible conductor path, electric and/or electronic circuits, and connection pads that can be formed in accordance with the invention;

Figures 6a and 6b are schematic side views that illustrate how a detector-adapted base structure can be formed from a die or mould and a model;

Figure 7 illustrates a discrete detector applied to a part belonging to a gas cell;

5 Figure 8 is a simplified illustration in side view that shows how a detector can be aligned or positioned in relation to a chosen angle of incidence of light rays;

10 Figure 9 illustrates schematically and from above how a detector can be isolated electrically from a surrounding metal layer;

15 Figure 10 is a schematic side view showing how a detector can be isolated electrically from a surrounding metal layer;

20 Figure 11 illustrates schematically and from above a detector that includes a plurality of columns of conductive ridges, and shows the columns interconnected electrically;

25 Figure 12 illustrates schematically and from above a detector according to Figure 11 with which the columns are interconnected electrically by means of electrically conductive surface sections;

30 Figure 13 illustrates schematically and from above how conductive and insulating ridges co-act to form a detector that may include a plurality of columns of conductive ridges;

35 Figure 14 illustrates schematically and in side view how conductive ridges can be adapted to absorb incident light rays; and

Figure 15 is a highly simplified, schematic illustration of a gas cell where the inner surfaces of the gas cell cavity have been provided with a number of detectors.

DESCRIPTION OF EMBODIMENTS AT PRESENT PREFERRED

The invention relates to a method of, *inter alia*, producing a gas sensor associated detector. The invention provides a high degree of freedom with regard to positioning of the detector as a separate unit or as a unit that is integral with gas sensor components, such as the gas cell.

The method has been described earlier under the heading "SOLUTION" and is described more succinctly in the following method Claims.

Consequently, the following description deals mainly with the gas sensor adapted detector.

Figure 1 thus illustrates, among other things, a detector 3, which is adapted to co-act with a gas sensor 1.

The illustrated kind of gas sensor 1 includes a gas cell 2 in which there is defined a cavity 21 that includes openings 21A, 21A' and/or openings 21B through which a volume of gas "G" to be measured or evaluated can enter and leave said cavity.

A device 1a for generating infrared light rays is adapted to generate light rays 4 and to direct the rays into the cavity 21.

The light rays 4 can be caused to reflect repeatedly against mutually opposing sections of the walls defining said cavity,

such as the illustrated wall sections 21C, 21D and 21E, and thereafter pass to a receiving detector 3.

The detector 3 has connected thereto one or more electric circuits or electronic circuits 1b which function to evaluate the intensity of the light received in the detector 3 and to evaluate the properties and/or the concentration of the gas "G" on the basis of the intensity of the light in the device 1a, among other things.

10

The gas cell 2 can be conceivably designed so that electromagnetic waves, such as light waves 4, entering the cavity 21 will fall on the detector 3 either directly or, as shown, after having been reflected an adapted number of times within the cavity 21. This latter alternative enables the light rays to cover an adapted path length or measuring path within the cavity 21, which may be necessary in absorption spectroscopy, for instance.

15

20

The gas cell 2 is normally constructed with the aid of a plurality of mechanical parts.

As will be seen from Figure 1, the gas cell 2 is comprised of a combination of a first part or component 2A and a second part or component 2B, of which at least the part 2A is made of a plastic material and has been formed by some sort of moulding or pressing process or by embossment against a die or mould, such as to enable the interior of the gas cell to be given an adapted interior shape, i.e. in the interior of the cavity 21. In the illustrated case, the second part 2B may consist in a flat plate B or a base structure.

25

30

The illustrated parts 2A and 2B are both made of a plastic material and their respective inner surfaces and/or wall parts have been provided with an electrically conductive

35

metal layer, so that said surfaces or wall parts will be highly light-reflective.

5 The light generating device 1a of the Figure 1 embodiment has been shown in the form of a separate component lying on a supporting base or plate B. The detector 3 is also shown as a separate component.

10 It will be apparent from the following description that these components can be integrated either with the part 2A or in the surface of the base structure B.

15 In the Figure 2 embodiment, the surfaces 21C, 21D and 21E that form the wall parts within the gas cell 2, or at least a part of said surfaces 21C, 21D and 21E, are usually coated with two different metal layers M1, M2 that consist of a selected first metal in a first layer M1, and a selected second metal in a second layer M1, this second layer being intended to form a highly reflective surface with respect to said
20 light rays 4, therewith enabling practically loss-free reflections to be achieved.

In the case of one application of this kind, the detector 3 is usually mounted in the close proximity of the gas cell at
25 a light-ray exit opening 22. In one design of the gas cell, there is formed a number of reflection surfaces which are so orientated that light rays 4 entering the gas cell 2 through an inlet opening 23 and allocated a predetermined direction into the gas cell 2 or the cavity 21, will be reflected
30 through the cavity in accordance with a predetermined pattern 21C, 21D and 21E and fall on the detector 3 at a predetermined angle of incidence "a".

35 International Patent Application PCT/SE96/01448, with Publication No. WO 97/187460, and the International Patent Application PCT/SE97/01366, with Publication No. WO 98/09152, dis-

close examples of earlier known gas sensors in which incoming light rays are repeatedly reflected within the cavity in accordance with a predetermined pattern. International Patent Application PCT/SE97/01366 is considered to constitute part of this description.

It is important that the detector 3 is aligned with respect to this angle of incidence "a" in the best possible way, so as to obtain a sufficiently good measuring signal. It is also important that the detector 3 has sufficiently high sensitivity to the signal to be detected.

Light sources that generate light waves in the infrared wavelength range are often used in conjunction with absorption spectroscopy, and consequently it is usual to use detectors consisting of thermal elements.

It is also known to use thermal elements in the form of temperature dependent resistance elements, such as Bolometers, or thermoelectric elements or thermocouples. The sensitivity of these elements is usually enhanced, by connecting several such elements in series.

The following description is concentrated, to a large extent, on the measures required to construct a detector in the form of a number of series-connected thermocouples.

Those skilled in this art will realise that the following proposals can be modified appropriately to provide series-connected resistance paths for a Bolometer.

According to the invention, at least the detector 3 constitutes a part of a surface. This surface may consist in an outer part within the wall parts of the cavity 21 and "cover" the opening 22 with connection lines drawn down towards the supporting base B in connection with the detector 3 of the

Figure 1 illustration, where requisite connecting pads are formed.

5 The detector 3 may alternatively be formed within a surface part of the part 2B that lies closely adjacent to the location of the detector 3, wherewith said part 2A is provided with a 45° reflectance surface immediately above said surface part and "covering" the opening 22.

10 Figure 3 shows, in accordance with the present invention, that the detector 3 is formed specifically on a body having the form of an underlying or base surface 31 or a part of a larger underlying supporting base surface B. In this case, that part of the underlying support surface 31 that forms the
15 actual detector 3 is comprised of one or more surface regions 3a formed topographically in a plastic element.

At least the surface region or regions 3a is/are coated with a first and a second electrically conductive metal layer M1,
20 M2, these layers being intended to form a thermocouple in accordance with Figure 4.

Those persons skilled in this particular art will realise that a Bolometer requires only a first electrically conductive metal layer on the topographically formed surface re-
25 gion.

In this case, the topographic structure shall form from the electrically conductive layer a loop whose electrical resistance varies with temperature. It is also possible to form a
30 first and a second loop by means of a topographic structure, where the first loop is allowed to be exposed to incident light rays and where the second loop is in the shadow of incident light rays as a result of the topographic structure,
35 therewith enabling compensation to be made for variations in background temperature.

In order to obtain a chosen conductive pattern, an electric and/or an electronic circuit and/or electric or electronic components, there is required a well-developed topographic configuration on the chosen surface region of the plastic element, and a particular metal coating application.

All persons skilled in this particular field are capable of creating a topographic pattern on an electrically insulating plate that will provide a desired printed circuit or the like subsequent to applying a metal layer or layers thereto.

It will be understood that in the illustrated case, the first metal layer M1 is applied to the surface region concerned at a first angle "b" other than 90° or the normal, and that the second metal layer M2 is applied at a second angle "c" other than 90° and differing from the first angle "b". These angles "b" and "c" normally lie in one and the same plane.

The topographic structure and/or the form 3a provided with electrically conductive coatings provides the function of one or more several thermocouples, by virtue of the first and the second metal layers M1, M2 being allowed to overlap within discrete surface parts of the detector.

Figure 5 shows the possibility of producing the detector 3 on a restricted surface region and to produce requisite electric circuitry 3' and/or electric and/or electronic circuits 3'' and requisite connection pads 3''' within this restricted surface region in the same way as that described above, i.e. by coating a topographic structure with one or more metal layers from different angles.

As illustrated in Figure 6a, it is proposed in accordance with the invention that the underlying support surface 31 is produced by shaping, such as moulding, pressing or embossing,

against a die or mould 31', where at least a part of the mould corresponding to the detector 3, according to Figure 6b, is produced by electroplating a model 31'' of the detector 3, said model 31'' being produced by micromechanically working a substrate, such as a silicon substrate, where the topographic structure and/or configuration of the model 31'' is chosen to correspond to desired surface parts of the detector, electric conductor paths and/or electric and/or electronic circuits.

10

Alternatively, the base unit 31 shown in Figure 6a can be produced by shaping, such as moulding, pressing or embossing, said unit against a die or mould 31', where at least a part of the mould corresponds to the detector 3 produced by micromechanically working a substrate, such as a silicon substrate, where the topographical structure and/or configuration of the substrate 31' is complementarily dependent on desired detector-associated surface parts, electric conductor paths and/or electrical and/or electronic circuits.

20

Figure 7 shows that the base unit 31 may consist of a discrete of separate component and applied to the first part 2A.

25

However, the most favourable embodiment for integrating the detector 3 in said cavity is that shown in Figure 3, where the base unit 31 constitutes an integral part of the first cell-part 2A, and where the detector-associated surface parts are an integral part of the surface belonging to said cavity 21.

30

35

Regardless of whether the base unit 31 is a discrete component in accordance with Figure 7 or an integral part of the first cell-part 2A, it is possible to coat the cavity-associated surface sections and the detector-associated surface parts at one and the same time, preferably with the same metals.

The present invention also enables the topographic structure to be adapted to provide the requisite connection pads 3''' belonging to said detector 3, electric conductor paths 3', and/or electric and/or electronic circuits 3''.

Alternatively, the electric conductor paths 3' and/or the electric and/or the electronic circuits 3'' can be formed in the second part 2B.

According to the present invention, the formed detector 3 may comprise an integral part of the first cell-part 2A, as illustrated in Figure 3. It is assumed in the remainder of the description that such is the case. The person skilled in this art will understand how the present method shall be applied when the formed detector does not constitute an integral part of the first cell-part 2A.

It is particularly convenient to provide the base unit with a number of conductive ridges 5, 5', 5''. Each of these conductive ridges has a first side surface 5a, a second side surface 5b and an upper surface 5c. An intermediate surface 6, designated here a conductive surface, is located between two mutually adjacent conductive ridges 5, 5'.

It should perhaps be mentioned that the expression "conductive ridges" may be somewhat misleading, since the topographic structure has the form of a greatly reduced "skyscraper structure", i.e. the structure is comprised of a plurality of narrow rods where the rods in one row (or column) may be slightly offset laterally with respect to the rods in adjacent alternate rows and with different rods of different heights.

As previously described with reference to Figures 3 and 4, the electrically non-conductive base unit 31 is coated with

the first metal M1 at a first angle "b" in relation to the detector surface, and with the second metal M2 at a second angle "c" relative to said detector surface.

5 The first angle "b" shall be adapted so that the first side surface 5a and at least a part of the upper surface 5c of respective conductive ridges 5, 5', 5'', and at least a part of the intermediate conductive surfaces 6 will be coated with the first metal layer M1, and the second angle "c" shall be adapted so that the second side surface 5b and at least a part of the upper surface 5c of respective conductive ridges 5, 5', 5'', and at least a part of the intermediate conductive surfaces 6 will be coated with the second metal layer M2, in accordance with Figure 4.

15

The first and the second angles "b", "c" shall be adapted so that the second metal layer overlaps the first metal layer M1 on the upper surface 5c of respective conductive ridges 5, 5' and on the intermediate conductive surfaces 6, 6' so as to form an electric contact with M12, M21, and so that the metal layers M1, M2 will form a series of electrically coupled ridges or transitions M12, M12', M21, M21' between the first and the second metals.

20

25 As evident from Figure 4, this results in a series of thermal elements, where the number of series-connected thermal elements corresponds to the number of ridges. In order to obtain an electrically functioning detector 3, it is necessary for all thermal elements to be insulated electrically from surrounding metal layers, i.e. that the metal layers M1, M2 in the detector-associated surface are electrically isolated at 71 from the metal layers M1R, M2R on the surrounding surface.

30

35 As illustrated in Figure 8, it is proposed in accordance with the present invention that the integrated part is aligned relative to the angle of incidence "a" of the incident light

4 by positioning the detector 3 in relation to incident light rays 4, such that said rays will irradiate the upper surface 5c of respective conductive ridges, and such that the intermediate conductive surfaces 6 will lie in the shade of the
5 conductive ridges with respect to incident light rays 4.

As will be seen from Figures 9 and 10, electric isolation, or insulation, 71, between the detector 3 and surrounding metal layers M1R, M2R is achieved with the aid of insulating ridges
10 81 with adjacent insulating surfaces 91 belonging to the integrated part are so positioned relative to each other and relative to the conductive ridges 5, 5', 5'' and relative to the first and to the second angle "b", "c" that both the first metal coating and the second metal coating will be ab-
15 sent on the insulated surfaces 71.

Figures 9 and 10 also show how a column of ridges is constructed. It is desirable to obtain a large number of series-coupled transitions from one metal to the other metal, in order to enhance the resolution, or sensitivity, of the detector 3. If it is necessary to increase the number of series-connected transitions, the detector surface will obtain a pronounced oblong shape. For reasons of measuring technology, however, it is desirable for the detector surface to have an
20 essentially square shape.
25

Accordingly, it is proposed in accordance with the invention that the conductive ridges have a configuration which comprises a number of columns of mutually parallel conductive
30 ridges, as shown in Figure 11, where the number of columns is "n", here designated column 1 (k1), column 2 (k2), and so on to column "n" (kn) where the number of conductive ridges in respective columns is "m", here designated ridge 1 (a1), ridge 2 (a2) and so on up to ridge "m" (am) and where "m" may
35 be different for respective columns.

In order for the ridges in respective columns to form a coherent series of junctions, it is proposed in accordance with the invention that the "m"th ridge "am" of each column, with the exception of the last column "kn", is coupled electrically 51 to the first ridge "a1" of the next following column.

In this way, the transitions between the first and the second metals belonging to all conductive ridges within all columns form a common series of electrically coupled junctions.

Figure 12 illustrates an embodiment in which the electric interconnection 51 between two ridges of two mutually adjacent columns k1, k2 can be effected by forming an electrically 15 conductive surface section 51' as said interconnection.

Figure 13 illustrates that an essentially square thermocouple can be constructed by combining electrically conductive ridges a1, a2 with insulating ridges 81.

20 It is also suggested in accordance with the present invention that the series of electrically conductive ridges form the series-connected thermocouples, where the metal layer on a first or on a second side surface of a first conductive ridge k1, a1, or a conductive surface adjacent said first conductive ridge, in the series of conductive ridges forms a first connection electrode 53 on the series-connected thermocouple, and that a first or a second side surface of a last conductive ridge kn, am, or a conductive surface adjacent said last 30 conductive ridge, in the series of conductive ridges, forms a second connection electrode 54 on the series-connected thermocouple.

Figure 14 is intended to show in particular that when the detector 3 is adapted to detect light rays within the infrared wavelength range, the upper surface 5c of a respective con-

ductive ridge may be covered with a heat-absorbent layer 55 and the intermediate conductive surfaces 6 covered with a heat-reflecting layer 56.

5 This is done so that the hot solder points constituting measuring points in the thermocouple and exposed to the incident light rays shall absorb the greatest possible part of the thermal energy present in incident light rays or beams. The cold solder points, i.e. the conductive surfaces between the
10 conductive ridges, shall not be subjected to incident light rays and are therefore shaded by the conductive ridges, as earlier described. However, certain amounts of stray light may occur in the cavity, and consequently it is desirable and appropriate to cover the cold solder points with a heat-
15 reflecting layer.

According to one preferred embodiment of the invention, the heat-absorbent coating 55 is comprised of a layer of carbon, whereas the heat-absorbent coating 56 is comprised of the re-
20 flective metal layers M1, M2.

The metal in one of the two metal layers M1 has a first reflection coefficient in relation to the light rays 4 and the metal in the other of the two metal layers M2 has a second
25 reflection coefficient in relation to the light rays 4. As can be seen from Figure 8 the incident light forms an angle "a" in relation to the detector-associated surface parts.

In order to limit the amount of light that is reflected down
30 between two adjacent ridges it is proposed that these are positioned relative to incident light rays so that the metal with the lowest reflection coefficient of the two reflection coefficients is the metal covering the side surface 5a that will face the incident light rays.

35

The two metals M1, M2 used shall be appropriate both with respect to optical properties, reflection of utilised light rays, and also with respect to their thermoelectric properties. Thus, the first metal M1 shall differ from the second metal M2 and said metals shall provide a thermoelectric effect in co-action with one another.

According to one preferred embodiment, the two metals are gold and chromium respectively, where chromium is the first, innermost metal M1, and gold is the second metal M2.

This is specifically advantageous if the detector is an integral part of the gas cell, since gold, on top of chromium, has very good optical characteristics.

It shall be noted that if the detector is not an integral part of the gas-cell, but is manufactured by itself and applied to the gas cell, or if the wall parts of the cavity in the gas cell can be covered as the two metals are applied to the surface regions of the detector, for instance through masking, then other metals than can be used with more advantageous thermoelectric characteristics.

It will also be understood that a gas cell can be provided or allocated with a plurality of detectors, within the concept of the invention. This possibility is illustrated in Figure 15, in which the first part 2A includes integrally two or more different detectors 31, 32, and/or by providing the second part 2B or further second parts with one or more detectors 33, 34.

The term rays of electromagnetic waves, light beams, and more specifically light rays or beams within the infrared wavelength range or infrared light has been used generally in this description. It will be understood, however, that the present invention is not restricted specifically to infrared

light and that all rays of electromagnetic waves that can be detected by thermocouples or the like can be used, such as electromagnetic waves within the microwave range, for instance.

5

It is pointed out that with the intention of facilitating an understanding of the invention, the devices and apparatus illustrated have been greatly enlarged and greatly simplified. In practical applications, the cavity in a gas cell will have dimensions in the regions of millimetres or a centimetre, whilst the detector and its ridges will have dimensions in the micrometer range. However, the present invention is not restricted to specific sizes of the components and said components may have any desired dimensions, in accordance with the requirements that prevail in respect of a particular application.

10

15

20

It will be understood that the invention is not restricted to the aforescribed and illustrated exemplifying embodiments thereof, and that modifications can be made within the concept of the invention as illustrated in the following Claims.

CLAIMS

1. A method to form a detector in co-action with a gas sensor and intended for detecting electromagnetic waves, such as infrared light rays, passing through a gas cell, wherein said gas cell defines a cavity which can enclose a volume of gas to be measured or evaluated, wherein a surface, or parts of a surface, that form wall-parts within said gas cell or cavity is/are covered with one or more different metal layers with the intention of forming a surface which is highly reflective with regard to said electromagnetic waves, and wherein said detector is a thermal element, **characterised** in that said detector is formed on an electrically non-conductive base structure; in that a part of said base structure intended to form said detector is comprised of one or more surface regions having a topographical structure; in that at least the surface region or surface regions exhibiting said topographical structure is/are covered with a first electrically conductive metal layer which is intended to form said thermal element; in that said first metal layer is applied to the surface structure at an angle of incidence other than 90°; and in that the topographical surface structure and/or configuration on which an electrically conductive layer has been thus applied provides the function of one or more thermal elements.

2. A method according to Claim 1, **characterised** in that said thermal element is a Bolometer.

3. A method according to Claim 1, **characterised** in that the surface region or surface regions of said topographical structure is/are coated with a second electrically conductive metal layer; in that said first metal layer is applied to the surface structure at a first angle of incidence other than 90°; in that said second metal layer is applied to said surface structure at a second angle of incidence other than 90°

and different to said first angle, and in that said first and said second metal layers are caused to overlap each other within discrete surface parts of said detector.

5 4. A method according to Claim 3, **characterised** in that said first metal layer and said second metal layer are comprised of metals which provide the function of a thermocouple at said discrete surface parts of said detector.

10 5. A method according to Claim 1, 2 or 3, **characterised** in that said detector is produced on a limited surface region; and in that electric conductors and/or electric circuits and/or electronic circuits are formed on said limited surface region in the same way.

15

6. A method according to Claim 5, **characterised** in that said base unit is produced by a topographical shaping operation, such as a moulding, pressing or embossing operation, against a die or mould that exhibits a complementary topographical structure; in that at least a part of said mould corresponding to said detector is produced by an electrode plating process or like process against a model that includes a topographical structure adapted with respect to said detector; in that said model is produced by micromechanically working a substrate, such as a silicon substrate; and in that the topographical structure and/or the configuration of said model is chosen to correspond to desired detector-associated surface parts, electric conductors, and/or electric and/or electronic circuits.

25
30

7. A method according to Claim 5, **characterised** in that said base unit is produced by a shaping operation, such as a moulding, pressing or embossing operation, against a die or mould that has a complementary topographical structure; in that at least a part of said mould corresponding to said detector is produced by micromechanically working a substrate,

35

such as a silicon substrate; and in that the topographical structure and/or the configuration of said substrate is complementary with respect to desired detector-associated surface parts, electric conductor paths, and/or electric and/or electronic circuits.

8. A method according to Claim 1, in which the gas cell is formed from a first and a second part which together form a cavity, **characterised** in that said base unit is applied to a surface part on the inside of said first cell part.

9. A method according to Claim 1, in which said gas cell is formed by a first and a second part which together define a cavity, **characterised** in that said base part is comprised of a part integral with said first cell part; and in that said detector-associated surface parts form a part of the inner surface of said cavity.

10. A method according to Claim 1, 3, 8 or 9, **characterised** in that the cavity-associated surface sections are coated at the same time as detector-associated surface parts, and with the same metal.

11. A method according to Claim 1 or 3, **characterised** in that said topographical structure is adapted to provide requisite connection pads belonging to said detector, electric conductors, and/or electric and/or electronic circuits.

12. A method according to Claim 8 or 9, **characterised** in that electric conductors and/or electric and/or electronic circuits are formed in said second cell part.

13. A method according to Claim 3, **characterised** in that the topographical structure belonging to said detector-associated surface part includes a number of so-called conductive ridges; in that said conductive ridges have a first side sur-

face, a second side surface, and an upper surface; in that a so-called conductive surface is located between two adjacent conductive ridges; in that said first angle is adapted so that said first side surface and at least a part of said upper surface of respective conductive ridges, and at least a part of said intermediate conductive surfaces are coated by said first metal layer; in that said second angle is adapted so that said second side surface and at least a part of said upper surface of respective conductive ridges, and at least a part of said intermediate conductive surfaces, are coated with said second metal layer; in that said first and second angles are adapted so that said second metal layers overlap and form an electric contact with said first metal layer on the upper surface of respective conductive ridges and on the intermediate conductive surfaces, such that said metal layers form a series of electrically interconnected junctions between said first and said second metal layers.

14. A method according to Claim 13, **characterised** in that said detector-associated surface parts are positioned relative to incident light rays, or electromagnetic waves, such that said incident light rays will irradiate said upper surface of respective conductive ridges, and such that said intermediate conductive surfaces will be shaded against incident light rays by said conductive ridges.

15. A method according to Claim 13, **characterised** by electrically insulating surface sections formed between said conductive ridges, with said intermediate conductive surfaces, and surrounding surface sections belonging to said base unit.

16. A method according to Claim 15, **characterised** in that said electric insulation is achieved by positioning so-called insulating ridges with adjacently located so-called insulating surfaces relative to each other and relative to said conductive ridges and also relative to said first and said sec-

ond angles, such as to exclude a coating of both said first and said second metal layers on said insulating surfaces.

17. A method according to Claim 13, **characterised** in that
5 said conductive ridges are given a configuration which forms
n-number of conductive ridges designated column 1, column 2
and so on up to column "n", wherein respective columns in-
clude m-number of conductive ridges designated ridge 1, ridge
10 2 and so on up to ridge "m", wherein "m" may be different in
respective columns; in that the first ridge in each column,
with the exception of the "n"th column, and the "m"th ridge
in each column with the exception of the last column, form
interconnecting ridge, wherein the "m"th ridge in each col-
15 electrically to the first ridge of the next following column;
and in that the resultant junctions between said first and
said second metal layers belonging to all conductive ridges
in all columns form said series of electrically intercon-
nected junctions.

20

18. A method according to Claim 17, **characterised** in that
the electrical interconnection between an "m"th ridge in a
column and a ridge 1 in an adjacent column is achieved by
forming an electrically conductive surface section between
25 said adjacent columns; and in that said conductive surface
section is connected electrically to interconnecting ridges
belonging to said adjacent columns but is insulated electri-
cally in other respects from said adjacent columns.

30 19. A method according to Claim 13, **characterised** in that
the series of conductive ridges forms a series-connected
thermocouple; in that the intermediate layer on a first or a
second side surface of a first conductive ridge, or a conduc-
tive surface adjacent to said first conductive ridge, in said
35 series of conductive ridges, forms a first thermocouple con-
necting electrode; and in that a first or a second side sur-

face of a last conductive ridge or a conductive surface adjacent said last conductive ridge in said series of conductive ridges forms a second thermocouple connecting electrode.

5 20. A method according to Claim 13, **characterised** in that said upper surface of respective conductive ridges is covered with a heat absorbing layer; and in that said intermediate conductive surfaces are covered with a heat-reflecting layer.

10 21. A method according to Claim 20, **characterised** in that said heat absorbing layer is comprised of carbon; and in that said heat-reflecting layer is comprised of said metal layers.

15 22. A method according to Claim 14, **characterised** in that the metal in one of said two metal layers has a first reflection coefficient in relation to said light rays, or electromagnetic waves, that the metal in the other of said two metal layers has a second reflection coefficient in relation to said light rays, or electromagnetic waves, and that said detector-associated surface parts are positioned relative to
20 incident light rays, or electromagnetic waves, so that the metal with the lowest reflection coefficient of said two reflection coefficients is the metal covering the side surface that will face said incident light rays, or electromagnetic
25 waves.

23. A method according to Claim 13, **characterised** in that the metal in said first metal layer differs from the metal in said second metal layer, such as to obtain a thermoelectric
30 effect between said first and said second metal layers.

24. A method according to Claim 22 or 23, **characterised** in that said two metal layers are comprised of gold covering chromium.

35

25. A method according to Claim 1, **characterised** in that said first cell part includes a surface section intended for two or more different detectors.

5 26. A method according to Claim 1 or 21, **characterised** in that said second cell part has a surface section intended for two or more detectors.

10 27. A detector in co-action with a gas sensor and intended for detecting electromagnetic waves, such as infrared light rays, passing through a gas cell, wherein said gas cell defines a cavity which can enclose a volume of gas to be measured or evaluated, wherein a surface, or parts of a surface, that form wall-parts within said gas cell or cavity is/are
15 covered with one or more different metal layers with the intention of forming a surface which is highly reflective with regard to said electromagnetic waves, and wherein said detector is a thermal element, **characterised** in that said detector is formed on an electrically non-conductive base structure;
20 in that a part of said base structure intended to form said detector is comprised of one or more surface regions having a topographical structure; in that at least the surface region or surface regions exhibiting said topographical structure is/are covered with a first electrically conductive metal
25 layer which is intended to form said thermal element; in that said first metal layer is applied to surface structures at an angle other than 90°; and in that the topographical surface structure and/or configuration provided with such an electrically conductive layer provides the function of one or more
30 thermal elements.

28. A detector according to Claim 27, **characterised** in that said thermal element is formed as series-connected resistances and function as a Bolometer.

35

29. A detector according to Claim 27, **characterised** in that the a surface region or surface regions of said topographical structure is/are coated with a second electrically conductive metal layer; in that said first metal layer has been applied
5 to surface structures at a first angle of incidence other than 90°; in that said second metal layer has been applied to said surface structures at a second angle other than 90° and different to said first angle of incidence, wherewith said first and said second metal layers mutually overlap within
10 discrete detector-associated surface parts.

30. A detector according to Claim 29, **characterised** in that said first and said second metal layers are comprised of metals which provide the function of a thermocouple at said discrete detector-associated surface parts.
15

31. A detector according to Claim 27, 28 or 29, **characterised** in that said detector is formed within a limited surface area; and in that electrical conductors and/or electrical circuits and/or electronic circuits have been provided in
20 said limited surface area in the same way.

32. A detector according to Claim 31, **characterised** in that said base structure has been produced by a topographically
25 shaping process, such as a moulding, pressing or embossing process against a die or mould that has a complementary topographic structure; in that at least a part of said die or mould that corresponds to said detector is produced by electroplating or like process on a model having a topographic
30 structure adapted to said detector; in that said model is produced by micromechanically working a substrate, such as a silicon substrate; and in that the topographic structure and/or the configuration of said model is chosen to correspond to desired detector-associated surface parts, electric
35 conductor paths, and/or electrical and/or electronic circuits.

33. A detector according to Claim 31, **characterised** in that said base structure has been produced by a shaping operation, such as a moulding, pressing or embossing operation, against
5 a die or mould that has a complementary topographic structure or configuration; in that at least a part of said die or mould that corresponds to said detector is produced by micro-mechanically working a substrate, such as a silicon substrate; and in that the topographical structure and/or the
10 die or mould for said substrate is complementary in relation to desired detector-associated surface parts, electric conductor paths, and/or electrical and/or electronic circuits.

34. A detector according to Claim 31, where a gas cell is
15 comprised of a first and a second part that are intended to mutually co-act to form a cavity, **characterised** in that said base structure is applied to a surface section of said first cell part.

20 35. A detector according to Claim 27, wherein said gas cell is comprised of a first and a second part which are intended to co-act mutually to form a cavity, **characterised** in that said base structure forms an integral part of said first cell part; and in that said detector-associated surface parts form
25 an integral part of the inner surface of said cavity.

36. A detector according to Claim 34 or 35, **characterised** in that the cavity-associated surface sections are coated at the same time as the detector-associated surface parts, and with
30 the same metal.

37. A detector according to Claim 27, **characterised** in that said topographical structure is adapted to provide requisite connection pads belonging to said detector, electric conductor paths, and/or electric and/or electronic circuits.
35

38. A detector according to Claim 34 or 35, **characterised** in that electric conductor paths and/or electric and/or electronic circuits are formed in said second cell part.

5 39. A detector according to Claim 29, **characterised** in that said topographical structure belonging to said detector-associated surface part includes a number of so-called conductive ridges; in that said conductive ridges have a first side surface, a second side surface and an upper surface; in
10 that an intermediate so-called conductive surface is located between mutually adjacent conductive ridges; in that said first angle is adapted so that said first side surface and at least a part of said upper surface of respective conductive
15 ridges, and at least a part of said intermediate conductive surface, is coated with said first metal layer; in that said second angle is adapted so that said second side surface and at least a part of said upper surface of respective conductive
20 ridges, and at least a part of said intermediate conductive surface, is coated with said second metal layer; in that said first and said second angles are adapted so that said second metal layers will overlap and provide electric contact with said first metal layer on said upper surface of respective
25 conductive ridges and on said intermediate conductive surfaces, such that said metal layers form a series of electrically interconnected junctions between said first and said second metal layers.

40. A detector according to Claim 39, **characterised** in that said detector-associated surface parts are positioned relative to incident light rays, or electromagnetic waves, so
30 that said incident light rays will irradiate said upper surface of respective conductive ridges and such that said conductive ridges will shadow said intermediate conductive surfaces against said incident light rays.

35

41. A detector according to Claim 39, **characterised** in that electrically insulated surface sections are formed between said conductive ridges, with said intermediate conductive surfaces, and surrounding surface sections of said base structure.

42. A detector according to Claim 41, **characterised** in that said electrical insulation can be achieved by positioning so-called insulating ridges having adjacent so-called insulating surfaces relative to each other and relative to said conductive ridges and also relative to said first and said second angle such as to exclude application of both said first and said second metal layers on said insulating surfaces.

43. A detector according to Claim 39, **characterised** in that said conductive ridges are configured to form n-number of columns of conductive ridges, said columns being designated here as column 1, column 2 and so on up to column "n", and where respective columns include m-number of conductive ridges, where said ridges are designated ridge 1, ridge 2 and so on up to ridge "m", where "m" can be different for respective columns; in that the first ridge in each column, with the exception of the "n"th column and the "m"th ridge within each column, with the exception of the last column, form interconnecting ridges, where the "m"th ridge in each column, with the exception of the last column, is connected electrically with the first ridge of the next following column; and in that the resultant junctions between said first and said second metal layers belonging to all conductive ridges in all columns form said series of electrically interconnected junctions.

44. A detector according to Claim 43, **characterised** in that adjacent columns include therebetween an electrically conductive surface section; in that said electrical interconnection between an "m"th ridge of a column and a first ridge in an

adjacent column is effected through said conductive surface section; and in that said conductive surface section is connected electrically with interconnecting ridges belonging to adjacent columns but electrically insulated from said adjacent columns in other respects.

45. A detector according to Claim 39, **characterised** in that the series of conducting ridges forms a series-connected thermocouple; in that the metal layer and a first or a second side surface of a first conducting ridge or a conductive surface adjacent said first conductive ridge in said series of conductive ridges forms a first thermocouple-connecting electrode; and in that a first or a second side surface of a last conductive ridge or a conductive surface adjacent said last conductive ridge in said series of conductive ridges forms a second thermocouple-connecting electrode.

46. A detector according to Claim 39, **characterised** in that the upper surface of respective conductive ridges is covered with an heat-absorbent layer; and in that said intermediate conductive surfaces are covered with an heat-reflecting layer.

47. A detector according to Claim 46, **characterised** in that said heat absorbing layer is a layer of carbon; and in that said heat-reflecting layer is comprised of said metal layers.

48. A detector according to Claim 40, **characterised** in that the metal in one of said two metal layers has a first reflection coefficient in relation to said light rays, or electromagnetic waves, that the metal in the other of said two metal layers has a second reflection coefficient in relation to said light rays, or electromagnetic waves, and that said detector-associated surface parts are positioned relative to incident light rays, or electromagnetic waves, so that the metal with the lowest reflection coefficient of said two re-

flection coefficients is the metal covering the side surface that will face said incident light rays, or electromagnetic waves.

5 49. A detector according to Claim 29, **characterised** in that the metal of said first metal layer is different from the metal of said second metal layer, such as to obtain a thermoelectric effect between said first and said second metal layers.

10

50. A detector according to Claim 49, **characterised** in that said two metal layers are comprised of gold covering chromium.

15

51. A detector according to Claim 27, **characterised** in that said first cell part includes a surface section intended for two or more detectors.

20

52. A detector according to Claim 27 or Claim 51, **characterised** in that said second cell part includes a surface section intended for one or more detectors.

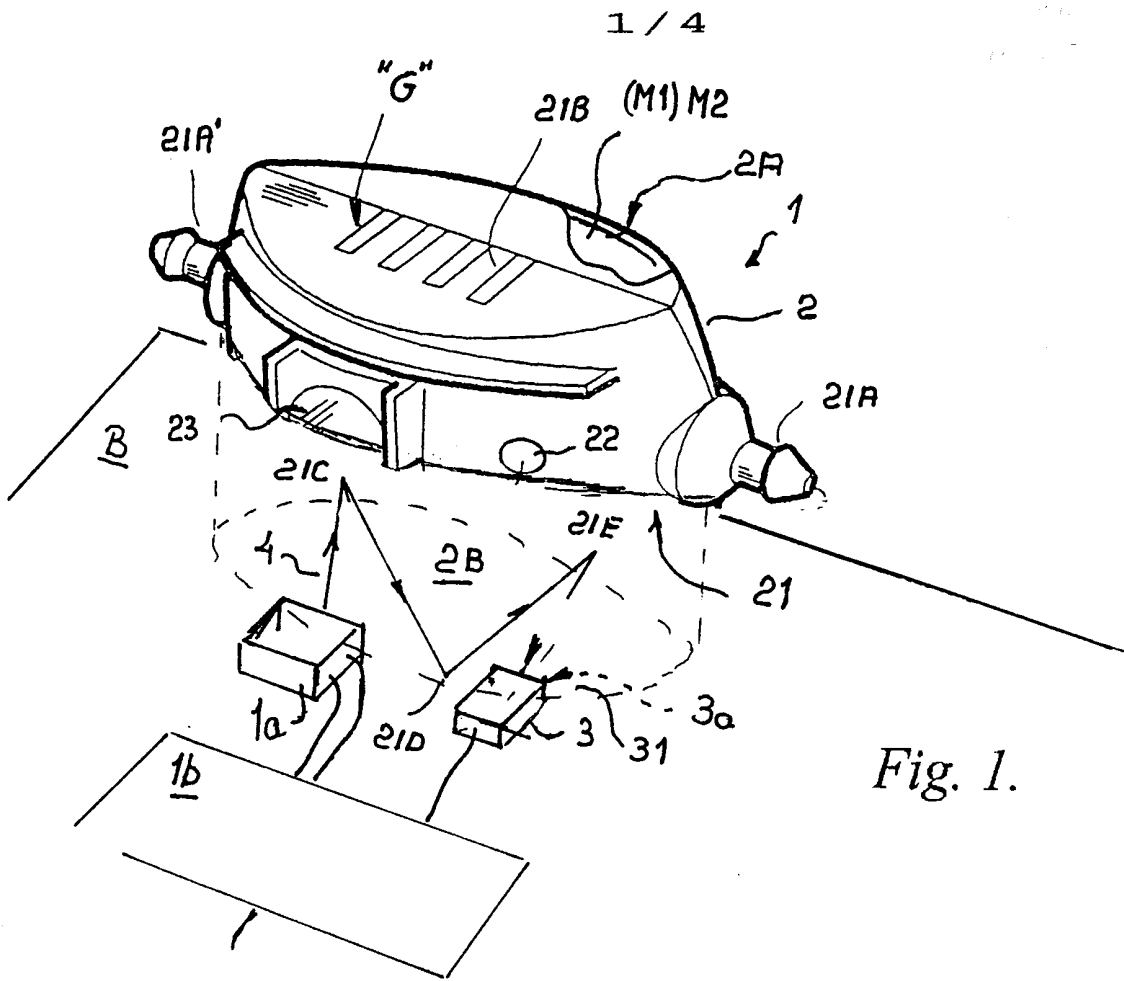

Fig. 1.

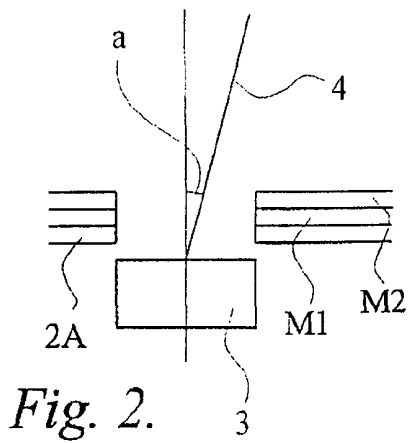

Fig. 2.

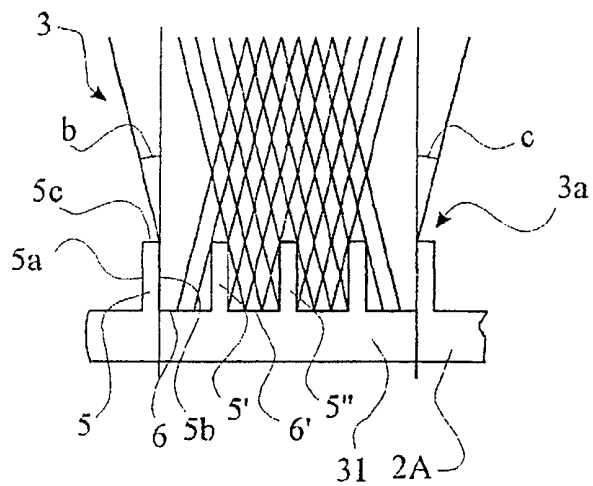

Fig. 3.

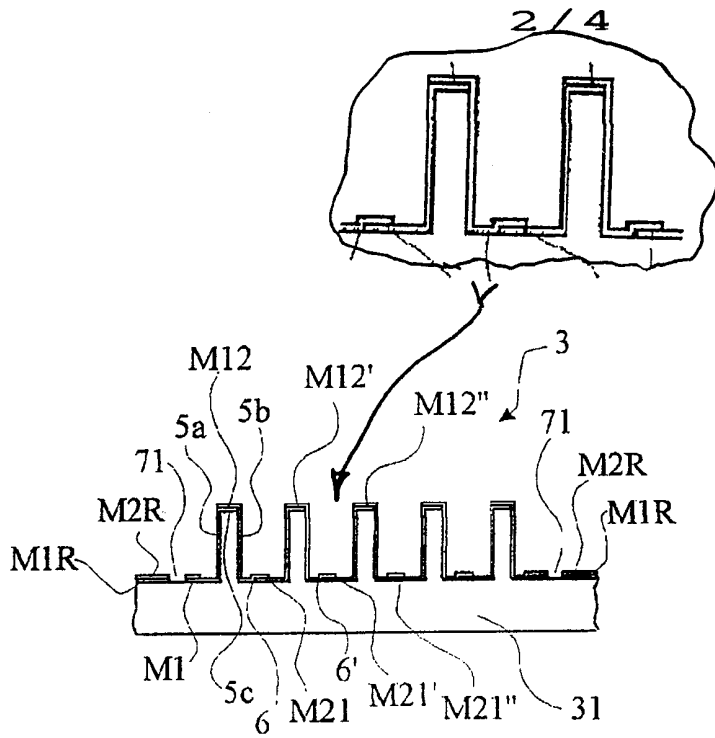

Fig. 4.

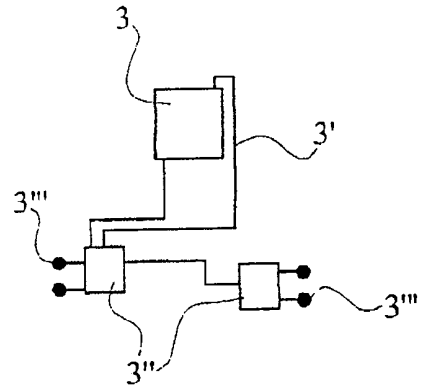

Fig. 5.

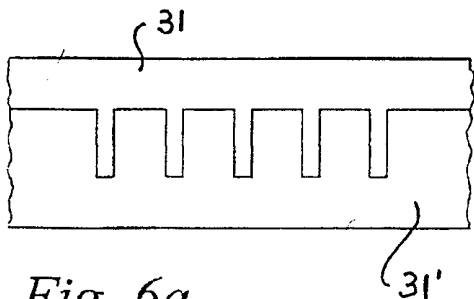

Fig. 6a.

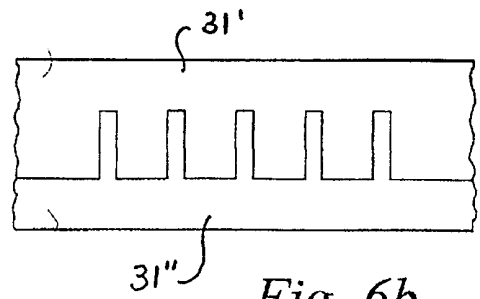
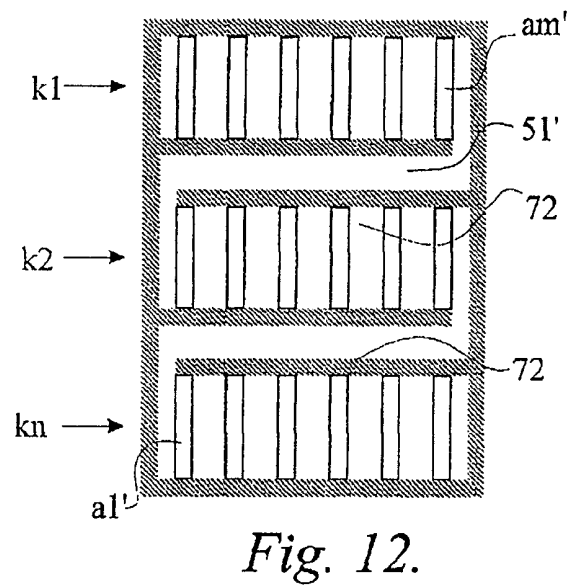
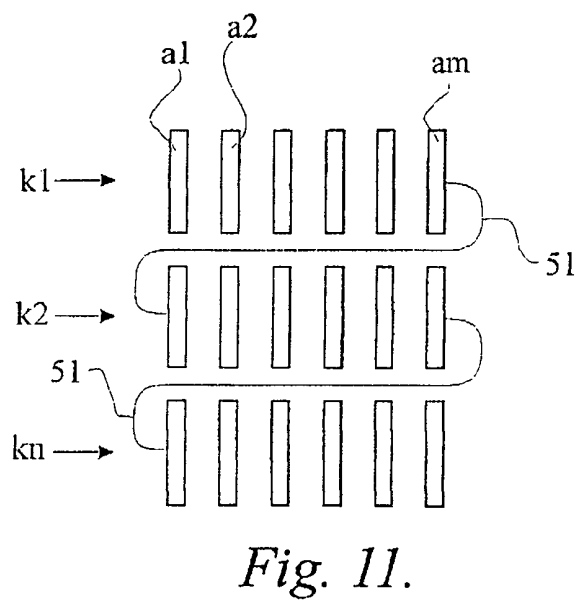
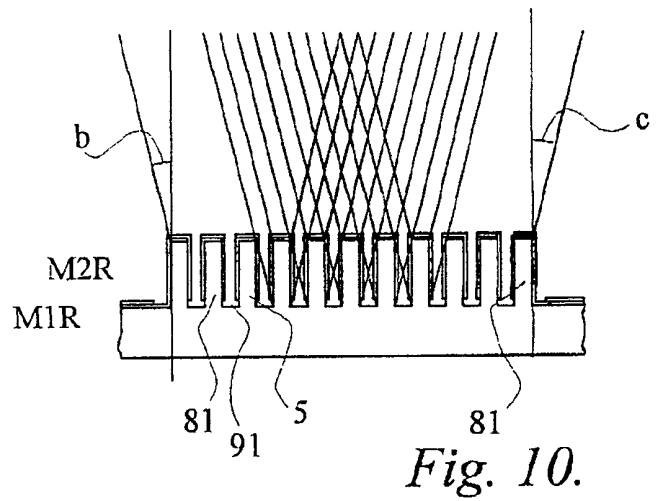
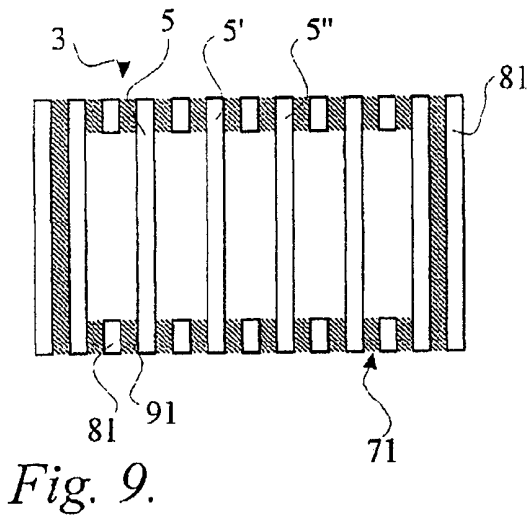
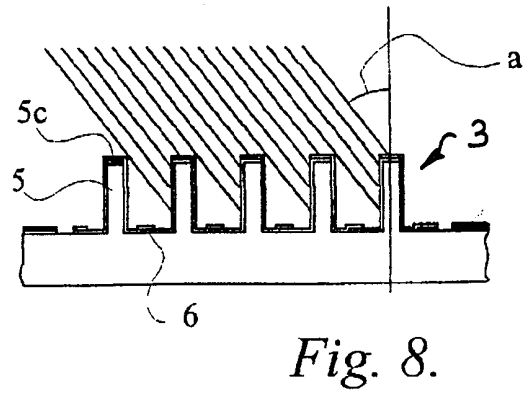
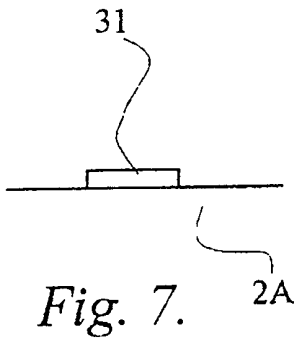
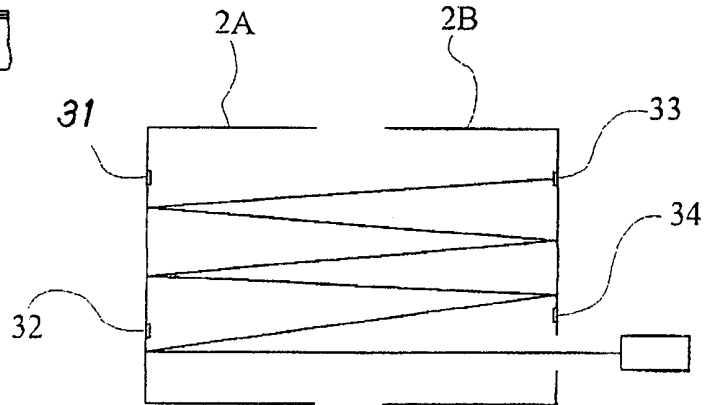
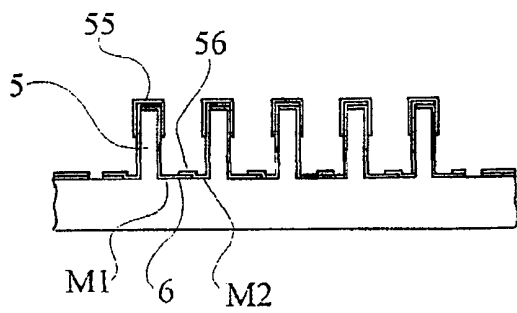
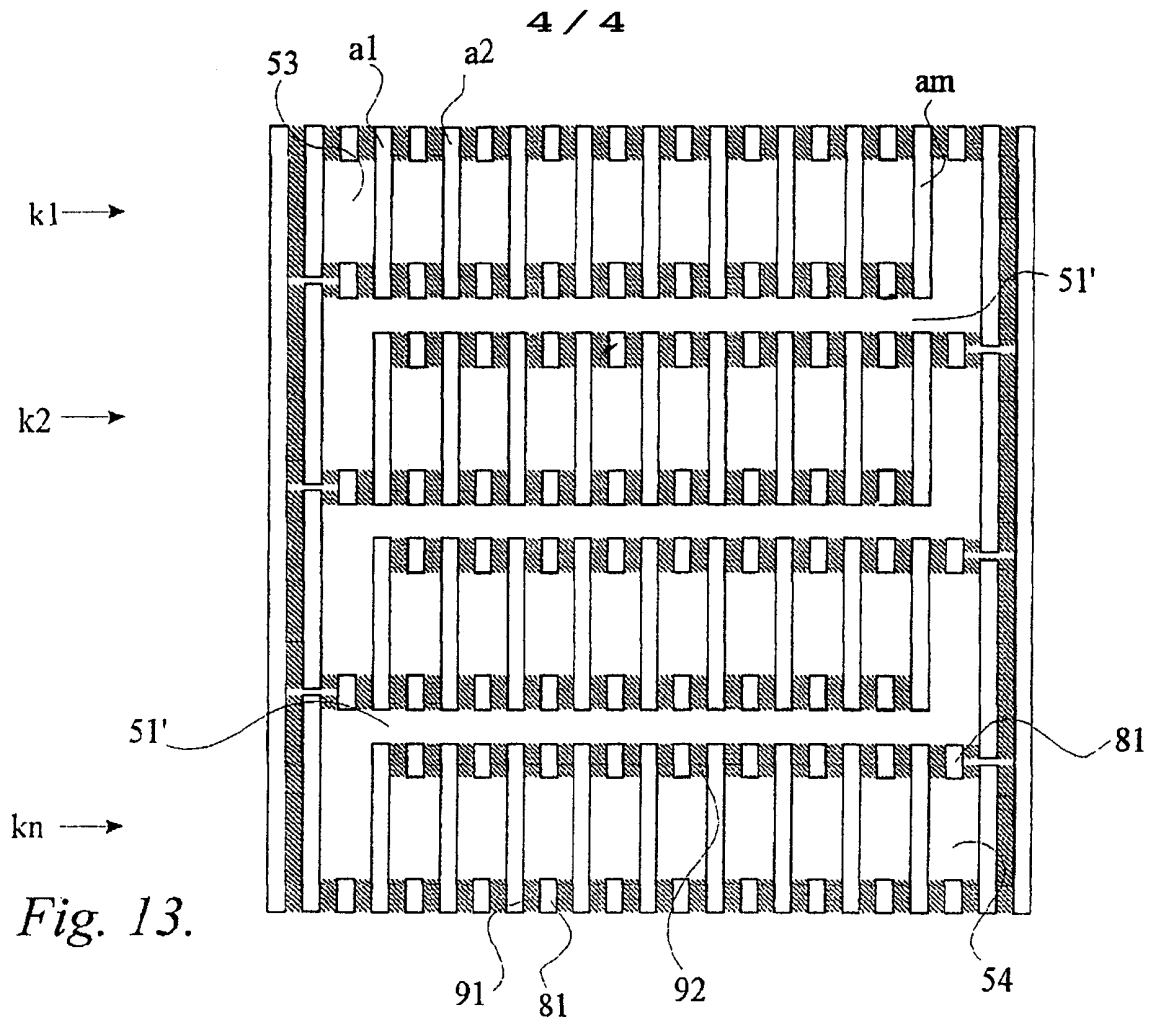

Fig. 6b.





INTERNATIONAL SEARCH REPORT

International application No.

PCT/SE 99/00145

A. CLASSIFICATION OF SUBJECT MATTER

IPC6: G01N 21/35, G01N 21/03, H01L 27/16, H01L 35/32
According to International Patent Classification (IPC) or to both national classification and IPC

B. FIELDS SEARCHED

Minimum documentation searched (classification system followed by classification symbols)

IPC6: H01L, G01N

Documentation searched other than minimum documentation to the extent that such documents are included in the fields searched

SE,DK,FI,NO classes as above

Electronic data base consulted during the international search (name of data base and, where practicable, search terms used)

WPI, EPODOC, TXTE, NPL

C. DOCUMENTS CONSIDERED TO BE RELEVANT

Category*	Citation of document, with indication, where appropriate, of the relevant passages	Relevant to claim No.
X	DE 4110653 A1 (LANDIS & GYR BETRIEBS AG), 23 January 1992 (23.01.92), figures 2,3 --	1-9,11-35, 37-52
A	US 5268782 A (ROBERT P. WENZ ET AL), 7 December 1993 (07.12.93) --	1-52
A	US 4029521 A (UZI KORN ET AL), 14 June 1977 (14.06.77) -- -----	1-52

Further documents are listed in the continuation of Box C. See patent family annex.

* Special categories of cited documents:

"A" document defining the general state of the art which is not considered to be of particular relevance

"E" earlier document but published on or after the international filing date

"L" document which may throw doubts on priority claim(s) or which is cited to establish the publication date of another citation or other special reason (as specified)

"O" document referring to an oral disclosure, use, exhibition or other means

"P" document published prior to the international filing date but later than the priority date claimed

"T" later document published after the international filing date or priority date and not in conflict with the application but cited to understand the principle or theory underlying the invention

"X" document of particular relevance: the claimed invention cannot be considered novel or cannot be considered to involve an inventive step when the document is taken alone

"Y" document of particular relevance: the claimed invention cannot be considered to involve an inventive step when the document is combined with one or more other such documents, such combination being obvious to a person skilled in the art

"&" document member of the same patent family

Date of the actual completion of the international search

4 June 1999

Date of mailing of the international search report

14 -06- 1999

Name and mailing address of the ISA/
Swedish Patent Office
Box 5055, S-102 42 STOCKHOLM
Facsimile No. +46 8 666 02 86

Authorized officer

Marianne Bratsberg/ELY
Telephone No. +46 8 782 25 00

INTERNATIONAL SEARCH REPORT
Information on patent family members

International application No.

03/05/99

PCT/SE 99/00145

Patent document cited in search report	Publication date	Patent family member(s)	Publication date
DE 4110653 A1	23/01/92	CH 680541 A FR 2664745 A,B	15/09/92 17/01/92
US 5268782 A	07/12/93	CA 2085631 A CN 1032167 B CN 1075016 A DE 69312099 D,T EP 0552104 A,B ES 2105142 T JP 5264982 A MX 9300134 A US 5545280 A	17/07/93 26/06/96 04/08/93 12/02/98 21/07/93 16/10/97 15/10/93 01/07/93 13/08/96
US 4029521 A	14/06/77	NONE	