

M. E. LAYNE.
 WELL MECHANISM.
 APPLICATION FILED NOV. 20, 1908.

998,186.

Patented July 18, 1911.

3 SHEETS—SHEET 1.

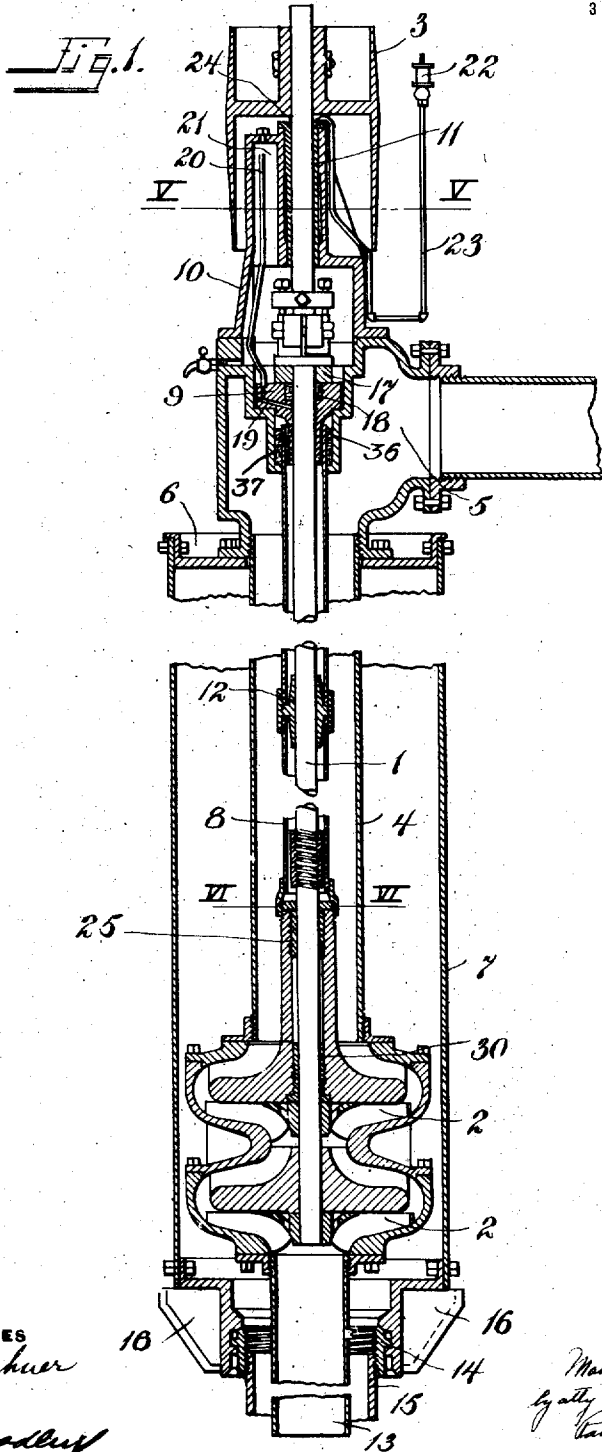

WITNESSES
Harvey L. Lechner
J. C. Bradley

INVENTOR
M. E. Layne
 by *Paul Chymcster*

998,186.

Patented July 18, 1911.

3 SHEETS—SHEET 2.

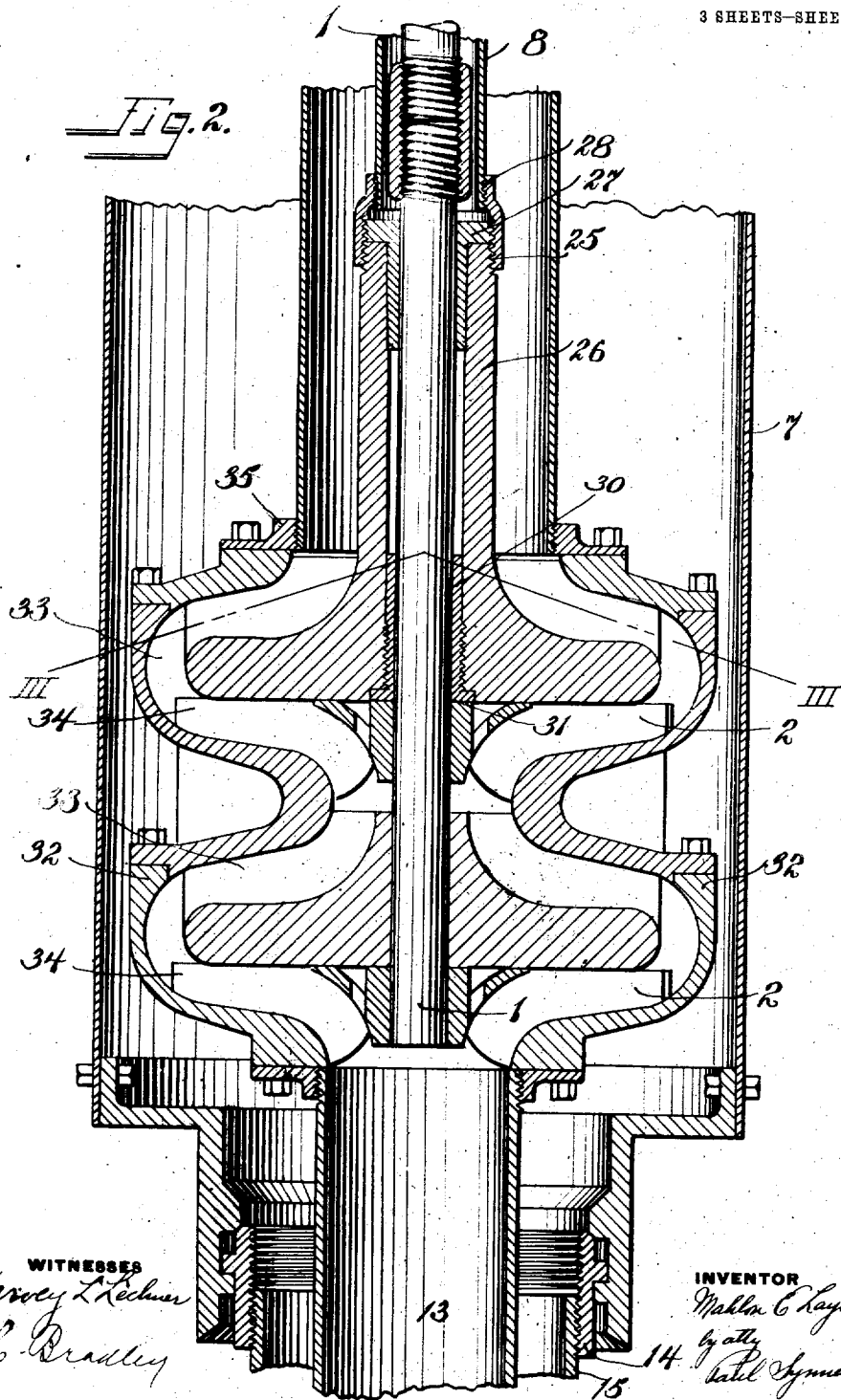

WITNESSES
Harvey L. Lechner
J. C. Bradley

INVENTOR
Malta C. Layne
by atty
Walter J. Symonds

M. E. LAYNE.
WELL MECHANISM.
APPLICATION FILED NOV. 20, 1908.

998,186.

Patented July 18, 1911.

3 SHEETS-SHEET 3.

Fig. 3.

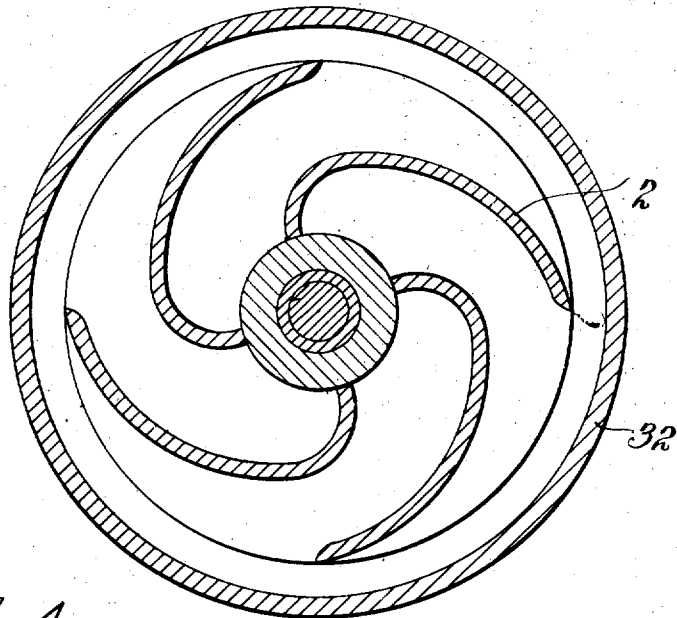

Fig. 4.

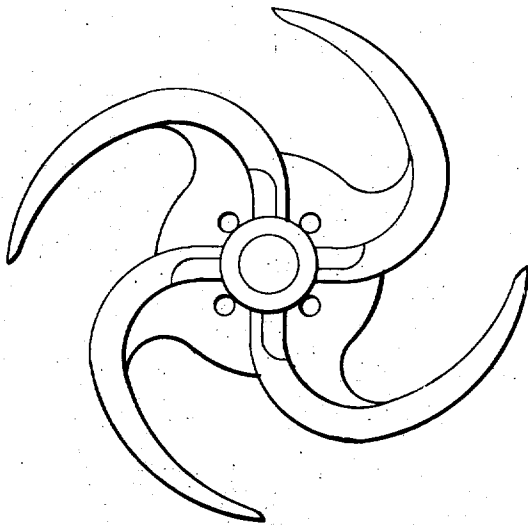

Fig. 5.

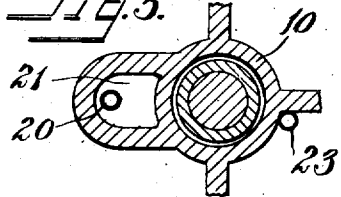
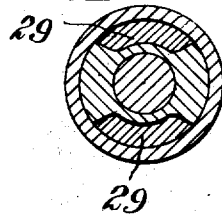

Fig. 6.



WITNESSES

Henry L. Lockwood
J. H. Bradley

INVENTOR

M. E. Layne
by atty *Paul Symonds*

UNITED STATES PATENT OFFICE.

MAHLON E. LAYNE, OF HOUSTON, TEXAS.

WELL MECHANISM.

998,186.

Specification of Letters Patent.

Patented July 18, 1911.

Application filed November 20, 1908. Serial No. 463,682.

To all whom it may concern:

Be it known that I, MAHLON E. LAYNE, a citizen of the United States, residing at Houston, in the county of Harris and State of Texas, have invented certain new and useful Improvements in Well Mechanisms, of which the following is a specification.

The invention relates to well mechanism and has for its principal objects; the provision of mechanism of this character employing an overhung vertical drive pulley wherein the space inside the over hang is utilized as a bearing and oil reservoir or pocket; the provision of improved and simplified means for securing the lubrication of the bearings of the mechanism; the provision of an improved centrifugal pump construction; and finally the provision of improved supporting bearings for the drive shaft at the pump casing. One embodiment of the invention is illustrated in the accompanying drawings, wherein:—

Figure 1 is a longitudinal section through the complete apparatus,

Figure 2 is an enlarged partial suction through the apparatus at the pump,

Figure 3 is a section on the line III—III of Figure 2,

Figure 4 is a detail end view of the blades of the pump, and

Figures 5 and 6 are sections respectively on the lines V—V and VI—VI of Figure 1.

Referring first to the general arrangement of parts as shown in Figure 1, 1 is the drive shaft carrying at its lower end the blades 2—2 of the centrifugal pump, 3 is the drive pulley clamped to the upper end of the drive shaft, 4 is the discharge casing in which the pump is located and which conducts the water to the laterally opening outlet casing 5; 6 is the plate at the upper ends of the steel pit 7, which plate supports the weight of its casing and that of the parts carried thereby, 8 is the shaft casing which separates the shafting and bearings from the water in the discharge casing 4, 9 is the bearing block which takes the longitudinal thrust on the drive shaft 1, and also supports such shaft laterally, 10 is the cap for the outlet casing 5, which cap has a bearing 11 for supporting the upper end of the drive shaft 1, 12 is a shaft guide secured to the shaft casing, 13 is the inlet pipe to the pump, 14 is the coupling for securing the

pit casing to the well casing, which coupling is described and claimed in my Patent No. 905440, issued Dec. 1, 1908, and 16—16 are the cutter blades used in sinking the pit casing.

The bearing block 9 carries upon its upper surface the thrust bearing 17, and is provided with the packing 18. This block is also provided with the oil passage 19, and the overflow pipe 20 extending upward from such oil passage 19. In order that the lubrication of the bearing 11 may be insured, the casing 10 is provided with the pocket 21, and the overflow pipe is extended into the upper portion of this pocket 21. Because of the packing 18, the oil which is supplied to the casing collects above the block 9 until its level rises above the end of the pipe 21. This arrangement insures a bath of oil about the bearing 11 extending up as high as the top of the pipe 20. The shape of the pocket 21 is indicated clearly from the cross sectional view of Fig. 5. As this pocket or reservoir 21 is inclosed by the overhang of the pulley 3 the additional space occupied is of no consequence, and the danger of the bearing 11 running dry is materially reduced. The oil for the interior of the cap 10 is supplied from the cap 22 whose pipe 23 extends up inside the overhung pulley and discharges into the groove 24 at the top of the bearing 11. The nut 36 above the packing 37 serves to couple block 9 to the shaft casing 8, and the shaft casing may thus be maintained in proper vertical alinement. The general construction of the bearing block 9 and the parts cooperating therewith are set forth in detail and claimed in my Patent No. 957,974, issued May 18, 1910, the departure in the present case from such construction in so far as the oiling means is concerned, residing primarily in the use of the oil pocket 21 with the pipe 20 therein for securing the proper lubrication of the bearing 11. The said patent, while disclosing a general well mechanism structure quite similar to that shown in this application, has its claims for the most part directed to and limited to the feature of employing a socket supported in the discharge casing and carrying the main thrust bearing of the drive shaft, to such feature in conjunction with the means for making a tight joint between the socket and

the shaft casing, and to the particular oiling construction for the thrust bearing in the socket, for which features of construction no claims are made in this application.

5 Another feature of invention resides in the means for supporting the drive shaft in the pump casing as illustrated in Figures 2 and 6. As here shown the sleeve 25 is provided fitting inside the inner pump casing 10 26. This sleeve or bushing is provided with a flange 27 at the top, which flange is threaded to engage the coupling 28. In order to still further guard against the turning of the sleeve with respect to the pump casing, the flange 27 is cut away as indicated 15 in Figure 6, and the lugs 29—29 from the top of the pump casing 26 extend up into the cut away portion, so that the parts are securely interlocked against relative rotative 20 movement. The shaft is still further supported in the pump casing 26, by means of the sleeve 30, which sleeve as shown in Figure 2 is screw threaded for a portion of its length and is provided with a head or 25 flange 31 which flange fits into a recess provided for it in the pump casing 26. By means of the sleeves 25 and 30 the shaft is securely supported in the pump casing, and removable bearings are provided of such 30 construction that all danger of the parts working out of place is avoided.

The pump construction and the manner of its support is shown in detail in Figures 2, 3 and 4. As here shown the pump casing 35 comprises the inner member 26 heretofore referred to, and the outer sectional casing member 32, the parts of such sectional casing being bolted together in the manner shown. Intermediate the two casings is 40 the curved passage 33, in which are mounted the two sets of blades 2—2, such blades being secured to the drive shaft 1. The blades 2—2 are preferably of the shape shown in Figures 3 and 4, and are so constructed that 45 their outer ends extend out past the outer circumference of the inner casing 26. By making the passage 33 in an unbroken curve, as illustrated in Figure 2, and by the use of the blades with their ends extending to the 50 points shown, the efficiency of the pump is very greatly increased. The outer casing member 32 is supported from the discharge casing 4 by means of the coupling 35, and the inner casing member 26 is supported 55 from the shaft casing 8 by means of the couplings 28 heretofore referred to. The threaded joints used throughout the construction are preferably made with right handed threads, and the pump blades are 60 turned to the left, so that the tendency of the rotation of the blades and shaft is to screw up the various couplings and joints instead of unscrewing them.

Having thus described my invention and illustrated its use, what I claim as new and 65 desire to secure by Letters Patent is the following:—

1. The combination with a shaft casing, a shaft, and pump casing, of a coupling for the shaft and pump casing, and a bearing 70 for the shaft comprising a sleeve threaded to the coupling and seated in and supported by the pump casing.

2. The combination with a shaft casing, a shaft, and a pump casing recessed to receive 75 a bearing, of a coupling for the shaft and pump casing, and a bearing for the shaft comprising a sleeve fitting inside the recess in the pump casing and provided with a threaded flange resting on the end of the 80 pump casing and engaging the threads on the coupling.

3. The combination with a shaft casing, a shaft, and pump casing, of a coupling for the shaft and pump casing, and a bearing 85 for the shaft comprising a sleeve fitting inside the pump casing and provided with a threaded flange resting on the end of the pump casing and engaging the threads on the coupling, and interlocking means on the 90 flange and the end of the pump casing.

4. In combination in well mechanism, a well pit casing, a rotary pump in the well pit casing; a drive shaft therefor, substantially concentric shaft and discharge cas- 95 ings secured to the pump at their lower ends and supported from the well pit casing at their upper portions, and means whereby the shaft and discharge casings may be adjusted relatively in a vertical direction to place the 100 shaft casing under tension and maintain it in vertical alinement.

5. The combination with a discharge casing and a shaft casing, of a pump casing 105 having its outer portion secured to the discharge casing and its inner portion to the shaft casing, a curved passage leading from the central lower portion of the pump out to the outer portion of the pump and thence 110 to the discharge portion, a shaft extending through the shaft casing and into the lower portion of the pump, and curved blades mounted on the shaft and extending out past the outer circumference of the inner portion 115 of the casing.

6. In combination in well mechanism for use in a vertical pit, a rotary pump comprising a casing and blades or runners, a drive shaft carrying the said blades or runners of the pump and extending upward 120 therefrom, shaft and discharge casings placed one inside the other and secured to the pump casing at their lower ends, the said shaft casing being sectional and provided with bearing means engaging the said 125 shaft, supporting means for the upper ends

of the two casings for maintaining them in relatively fixed positions during the operation of the mechanism, and means whereby the shaft and discharge casings may be adjusted relatively in a vertical direction to place the shaft casing under tension and maintain it in vertical alinement.

In testimony whereof I have hereunto signed my name in the presence of the two subscribed witnesses.

MAHLON E. LAYNE.

Witnesses:

JNO. ILFREY,
H. MALSCH.

DISCLAIMER.

998,186.—*Mahlon E. Layne*, Houston, Tex. WELL MECHANISM Patent dated July 18, 1911. Disclaimer filed July 2, 1912, by the patentee.

Enters this disclaimer—

“To the subject matter of claims 4 and 6 of said Letters Patent, which claims are in the following words, to wit:

“4. In combination in well mechanism, a well pit casing, a rotary pump in the well pit casing, a drive shaft therefor, substantially concentric shaft and discharge casings secured to the pump at their lower ends and supported from the well pit casing at their upper portions, and means whereby the shaft and discharge casings may be adjusted in a vertical direction to place the shaft casing under tension and maintain it in vertical alinement.

“6. In combination in well mechanism for use in a vertical pit, a rotary pump comprising a casing and blades or runners, a drive shaft carrying the said blades or runners of the pump and extending upward therefrom, shaft and discharge casings placed one inside the other and secured to the pump casing at their lower ends, the said shaft casing being sectional and provided with bearing means engaging the said shaft, supporting means for the upper ends of the two casings for maintaining them in relatively fixed positions during the operation of the mechanism, and means whereby the shaft and discharge casings may be adjusted relatively in a vertical direction to place the shaft casing under tension and maintain it in vertical alinement.

[*Official Gazette*, July 16, 1912.]

Disclaimer in Letters Patent No. 998,186.

of the two casings for maintaining them in relatively fixed positions during the operation of the mechanism, and means whereby the shaft and discharge casings may be adjusted relatively in a vertical direction to place the shaft casing under tension and maintain it in vertical alinement.

In testimony whereof I have hereunto signed my name in the presence of the two subscribed witnesses.

MAHLON E. LAYNE.

Witnesses:

JNO. ILFREY,
H. MALSCH.

DISCLAIMER.

998,186.—*Mahlon E. Layne*, Houston, Tex. WELL MECHANISM Patent dated July 18, 1911. Disclaimer filed July 2, 1912, by the patentee.

Enters this disclaimer—

“To the subject matter of claims 4 and 6 of said Letters Patent, which claims are in the following words, to wit:

“4. In combination in well mechanism, a well pit casing, a rotary pump in the well pit casing, a drive shaft therefor, substantially concentric shaft and discharge casings secured to the pump at their lower ends and supported from the well pit casing at their upper portions, and means whereby the shaft and discharge casings may be adjusted in a vertical direction to place the shaft casing under tension and maintain it in vertical alinement.

“6. In combination in well mechanism for use in a vertical pit, a rotary pump comprising a casing and blades or runners, a drive shaft carrying the said blades or runners of the pump and extending upward therefrom, shaft and discharge casings placed one inside the other and secured to the pump casing at their lower ends, the said shaft casing being sectional and provided with bearing means engaging the said shaft, supporting means for the upper ends of the two casings for maintaining them in relatively fixed positions during the operation of the mechanism, and means whereby the shaft and discharge casings may be adjusted relatively in a vertical direction to place the shaft casing under tension and maintain it in vertical alinement.

[*Official Gazette*, July 16, 1912.]

Disclaimer in Letters Patent No. 998,186.

DISCLAIMER.

998,186.—*Mahlon E. Layne*, Houston, Tex. WELL MECHANISM Patent dated July 18, 1911. Disclaimer filed July 2, 1912, by the patentee.

Enters this disclaimer—

“To the subject matter of claims 4 and 6 of said Letters Patent, which claims are in the following words, to wit:

“4. In combination in well mechanism, a well pit casing, a rotary pump in the well pit casing, a drive shaft therefor, substantially concentric shaft and discharge casings secured to the pump at their lower ends and supported from the well pit casing at their upper portions, and means whereby the shaft and discharge casings may be adjusted in a vertical direction to place the shaft casing under tension and maintain it in vertical alinement.

“6. In combination in well mechanism for use in a vertical pit, a rotary pump comprising a casing and blades or runners, a drive shaft carrying the said blades or runners of the pump and extending upward therefrom, shaft and discharge casings placed one inside the other and secured to the pump casing at their lower ends, the said shaft casing being sectional and provided with bearing means engaging the said shaft, supporting means for the upper ends of the two casings for maintaining them in relatively fixed positions during the operation of the mechanism, and means whereby the shaft and discharge casings may be adjusted relatively in a vertical direction to place the shaft casing under tension and maintain it in vertical alinement.

[*Official Gazette, July 16, 1912.*]