



(12) **EUROPEAN PATENT APPLICATION**

(88) Date of publication A3:  
**06.03.2013 Bulletin 2013/10**

(51) Int Cl.:  
**B22C 9/02** (2006.01) **B22C 9/10** (2006.01)  
**B22D 27/04** (2006.01)

(43) Date of publication A2:  
**30.06.2010 Bulletin 2010/26**

(21) Application number: **09175735.1**

(22) Date of filing: **12.11.2009**

(84) Designated Contracting States:  
**AT BE BG CH CY CZ DE DK EE ES FI FR GB GR HR HU IE IS IT LI LT LU LV MC MK MT NL NO PL PT RO SE SI SK SM TR**  
 Designated Extension States:  
**AL BA RS**

(72) Inventor: **Rao, Srinivas**  
**Oshkosh, WI 54901 (US)**

(74) Representative: **Illingworth-Law, William Illingworth**  
**Global Patent Operation - Europe**  
**GE International Inc.**  
**15 John Adam Street**  
**London WC2N 6LU (GB)**

(30) Priority: **18.11.2008 US 273243**

(71) Applicant: **Nuovo Pignone S.p.A.**  
**50127 Florence (IT)**

(54) **Temperature controlled mold**

(57) A sand based mold (18) and method for casting a device (10) having a cavity (16). The sand based mold (18) includes a core part (24) including grains of sand bonded with a resin, where a shape of the core part (24) fits a shape of the cavity (16) of the device (10), and a

first pipe (36) embedded into the core part (24) and configured to allow a compressed fluid to flow through the first pipe (36) during a solidification process of the device (10), the first pipe (36) having an inlet (38) and an outlet (40) that exit the mold (18).

**Figure 7**

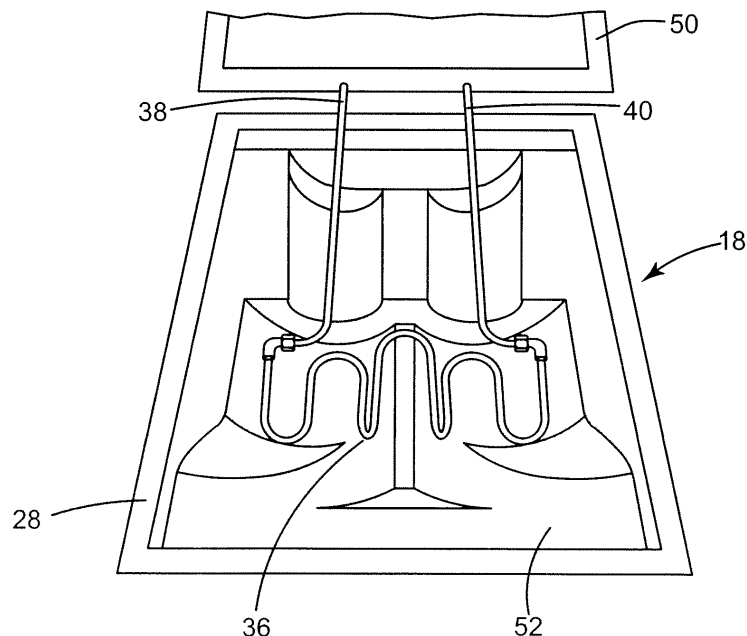



EUROPEAN SEARCH REPORT

Application Number  
EP 09 17 5735

DOCUMENTS CONSIDERED TO BE RELEVANT			
Category	Citation of document with indication, where appropriate, of relevant passages	Relevant to claim	CLASSIFICATION OF THE APPLICATION (IPC)
X	US 4 729 419 A (NAKAMURA SHIRO [JP] ET AL) 8 March 1988 (1988-03-08) * the whole document *	1-7,9-13	INV. B22C9/02 B22C9/10 B22D27/04
A	-----	15	
X	GB 2 099 341 A (SIEMPELKAMP GMBH & CO) 8 December 1982 (1982-12-08) * the whole document *	1-7,9-13	
A	-----	15	
X	JP 4 084662 A (ENDOU JIYUSHI MOORUDO KK) 17 March 1992 (1992-03-17) * abstract *	1,2	
A	----- JP 2004 143937 A (AISIN TAKAOKA LTD) 20 May 2004 (2004-05-20) * the whole document * *	15	
			TECHNICAL FIELDS SEARCHED (IPC)
			B22C B22D
The present search report has been drawn up for all claims			
Place of search Munich		Date of completion of the search 21 January 2013	Examiner Scheid, Michael
CATEGORY OF CITED DOCUMENTS X : particularly relevant if taken alone Y : particularly relevant if combined with another document of the same category A : technological background O : non-written disclosure P : intermediate document		T : theory or principle underlying the invention E : earlier patent document, but published on, or after the filing date D : document cited in the application L : document cited for other reasons ..... & : member of the same patent family, corresponding document	

1  
EPO FORM 1503 03/02 (P04C01)

**ANNEX TO THE EUROPEAN SEARCH REPORT  
ON EUROPEAN PATENT APPLICATION NO.**

EP 09 17 5735

This annex lists the patent family members relating to the patent documents cited in the above-mentioned European search report. The members are as contained in the European Patent Office EDP file on The European Patent Office is in no way liable for these particulars which are merely given for the purpose of information.

21-01-2013

Patent document cited in search report		Publication date	Patent family member(s)	Publication date
US 4729419	A	08-03-1988	CA 1284014 C	14-05-1991
			CN 86107495 A	08-07-1987
			JP 62144850 A	29-06-1987
			JP 63032536 B	30-06-1988
			US 4729419 A	08-03-1988
			US 4785871 A	22-11-1988
-----				
GB 2099341	A	08-12-1982	BE 893222 A1	16-09-1982
			CH 660317 A5	15-04-1987
			DE 3120221 A1	09-12-1982
			FR 2506191 A1	26-11-1982
			GB 2099341 A	08-12-1982
-----				
JP 4084662	A	17-03-1992	JP 4084662 A	17-03-1992
			JP 7000224 B	11-01-1995
-----				
JP 2004143937	A	20-05-2004	NONE	
-----				