

(12) **UK Patent Application** (19) **GB** (11) **2464405** (13) **A**

(43) Date of A Publication

**21.04.2010**

(21) Application No: **0918226.2**  
(22) Date of Filing: **16.10.2009**  
(30) Priority Data:  
(31) **12252613** (32) **16.10.2008** (33) **US**

(51) INT CL:  
**H04M 1/60** (2006.01) **H04B 1/38** (2006.01)  
(56) Documents Cited:  
**WO 2009/111404 A1** **WO 2009/102889 A1**  
**WO 2007/140367 A3** **US 7010139 B1**  
**US 20090226020 A1** **US 20040202344 A1**

(71) Applicant(s):  
**Sonitus Medical Inc**  
**Suite 350, 1825 S. Grant Street, San Mateo,**  
**CA 94402, United States of America**

(58) Field of Search:  
INT CL **A61F, G02C, H04B, H04M, H04R**  
Other: **On-Line - EPODOC, INSPEC, WPI**

(72) Inventor(s):  
**Amir Abolfathi**  
**Reza Kassayan**

(74) Agent and/or Address for Service:  
**J A Kemp & Co.**  
**14 South Square, Gray's Inn, LONDON, WC1R 5JJ,**  
**United Kingdom**

(54) Title of the Invention: **Systems and methods to provide communication, positioning and monitoring of user status**

Abstract Title: **Tooth-borne bone conduction communication apparatus**

(57) A communication apparatus includes a bone conduction communication apparatus with a housing having a shape which is conformable to at least a portion of at least one tooth of a user. A transceiver is mounted in the housing and a transducer is disposed within or upon the housing and in vibratory communication with a surface of the at least one tooth to transmit sound through the at least one tooth. A positioning system (eg GPS) is provided to transmit positional information to the transceiver to be delivered to the user via the transducer; and a communication device links the transceiver with a second person. The electronic and transducer assembly may receive incoming sounds either directly or through a receiver to process and amplify the signals and transmit the processed sounds via a vibrating transducer element coupled to a tooth or other bone structure, such as the maxillary, mandibular, or palatine bone structure. May be used in conjunction with ear protection in noisy environments such as war fields and may include a motion sensor to detect forces imposed on a soldier, which may actuate an inflatable vest or harden linkage attached to a helmet.

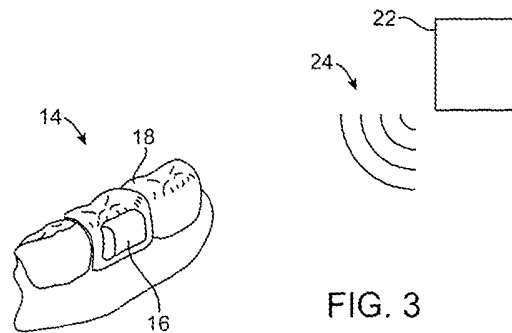

FIG. 3

**GB 2464405 A**

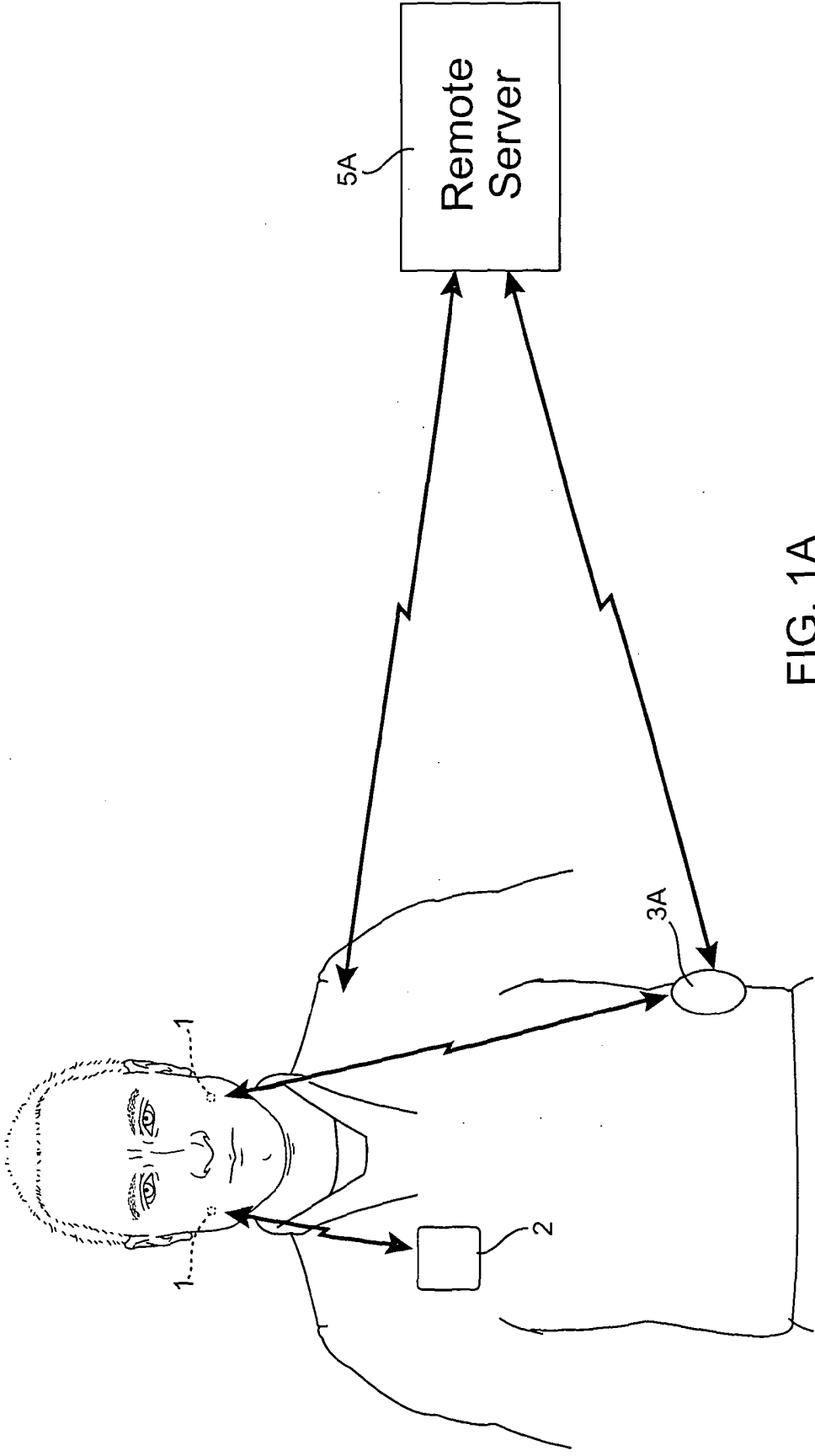

FIG. 1A

+

+

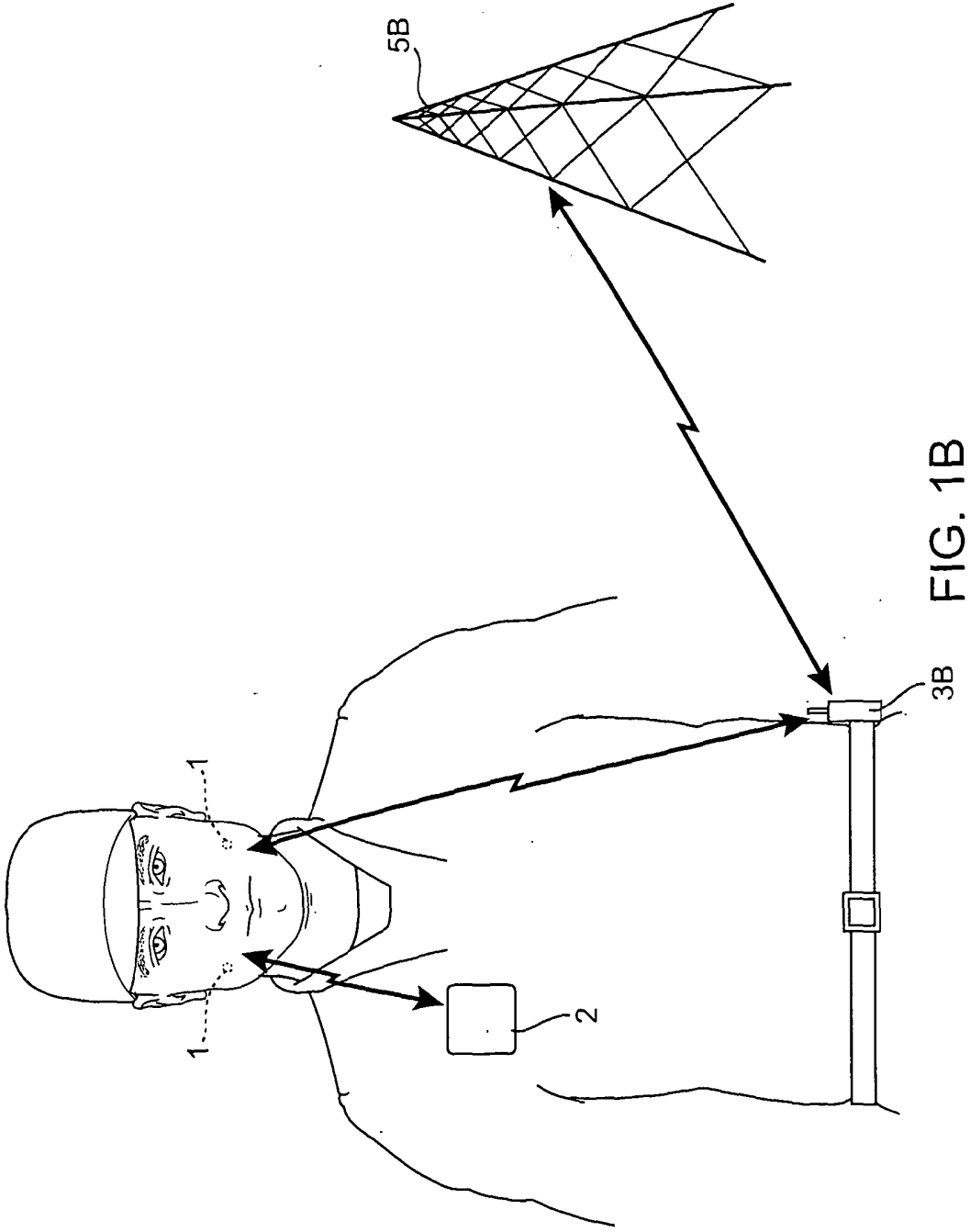

FIG. 1B

+

+

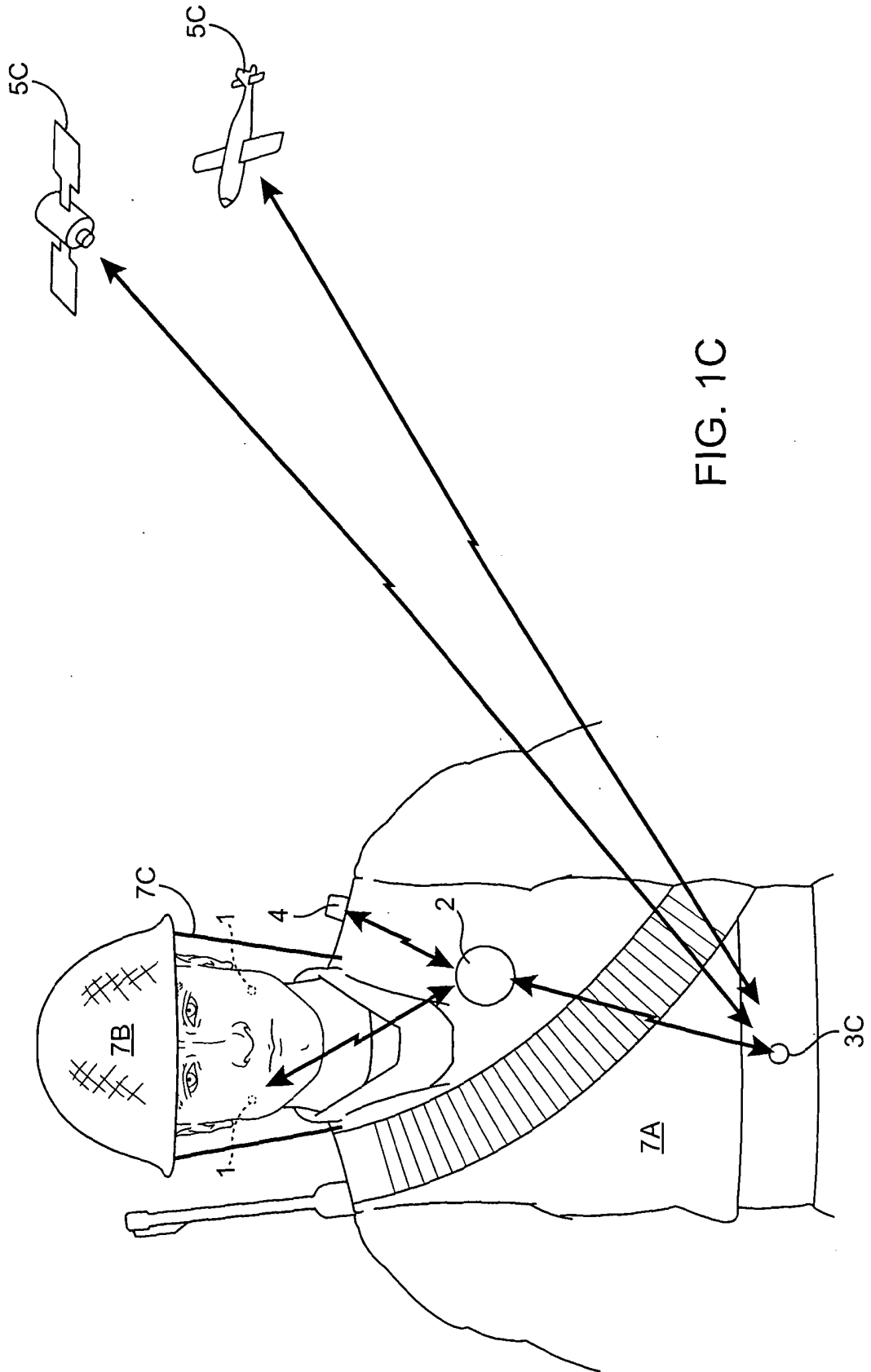

FIG. 1C

+

+

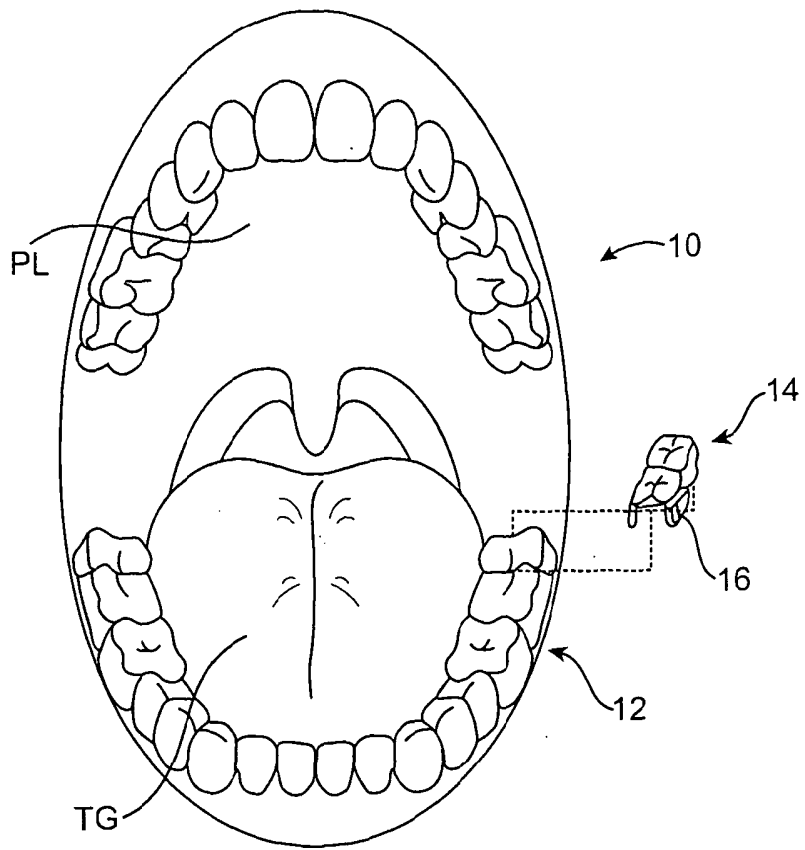

FIG. 1D

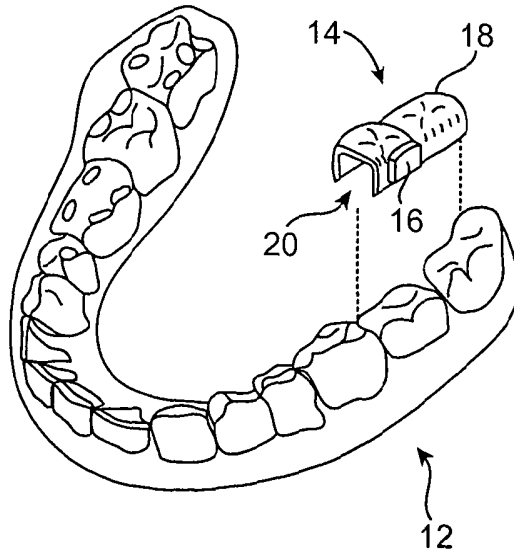

FIG. 2A

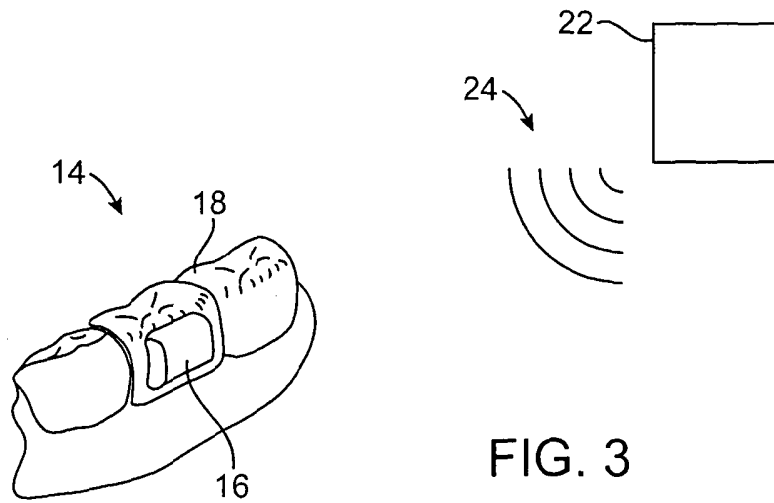

FIG. 3

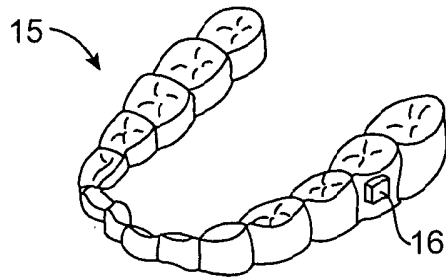

FIG. 2B

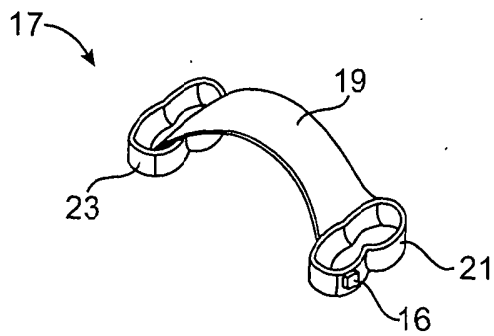

FIG. 2C

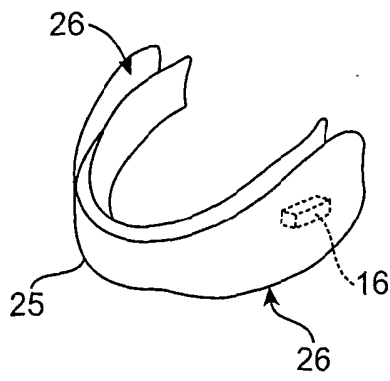

FIG. 2D



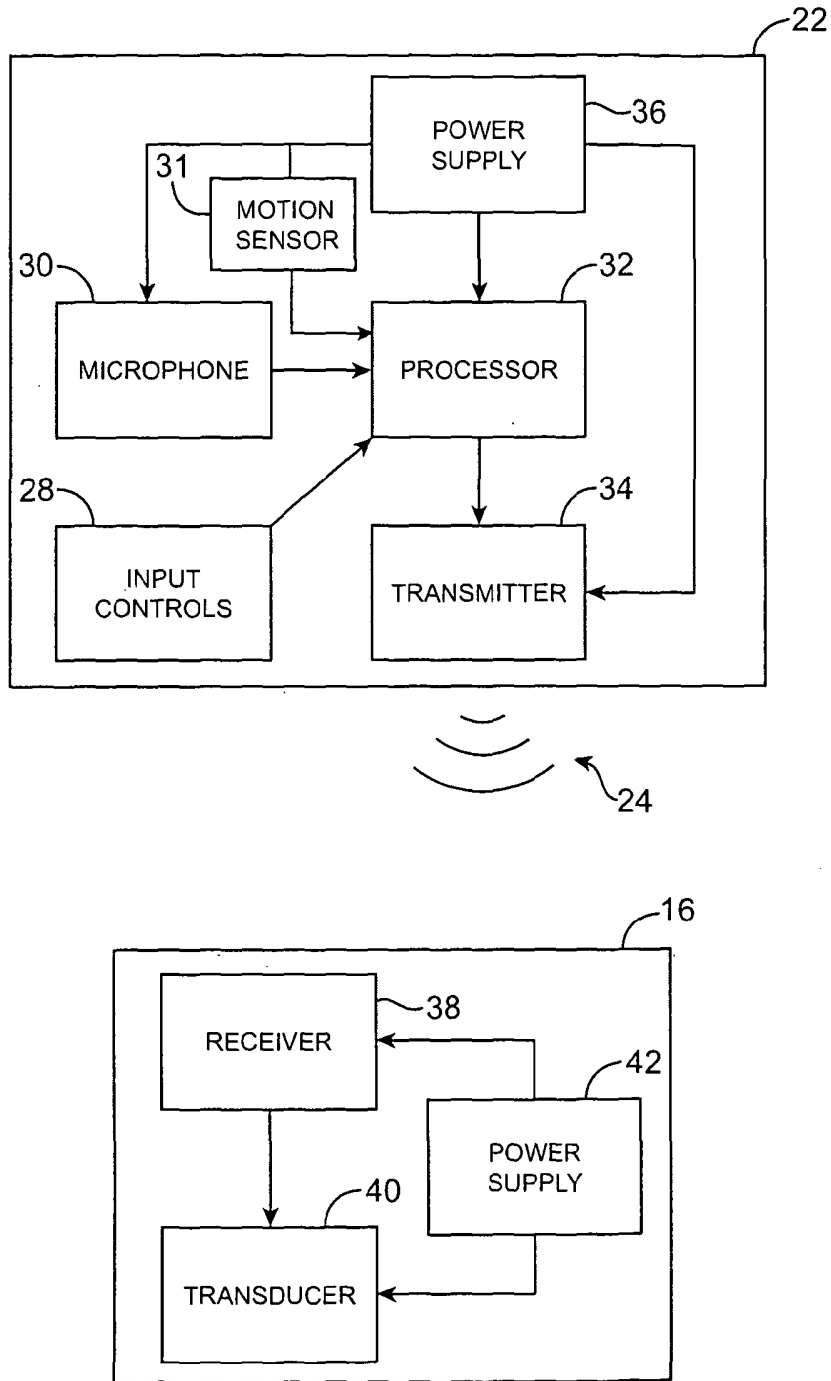

FIG. 4

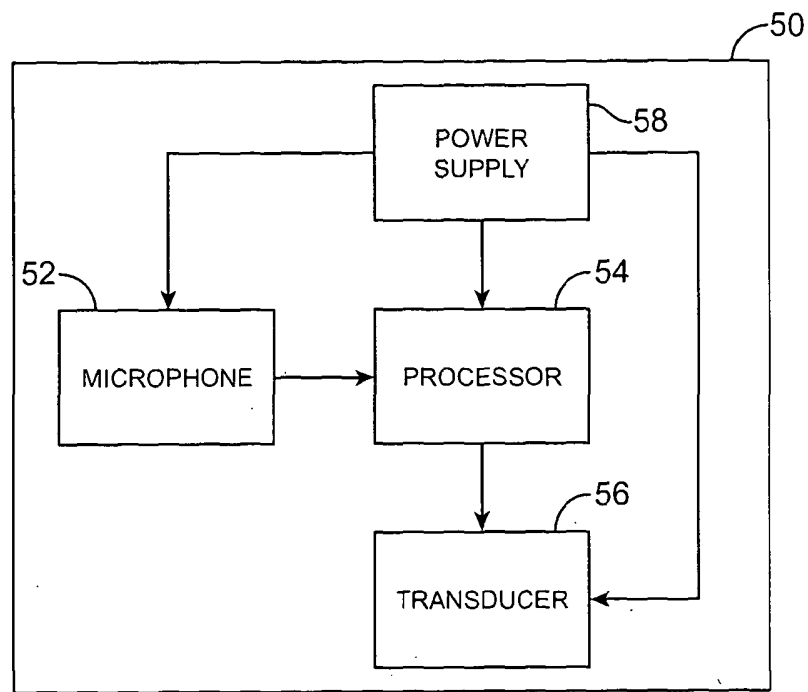

FIG. 5

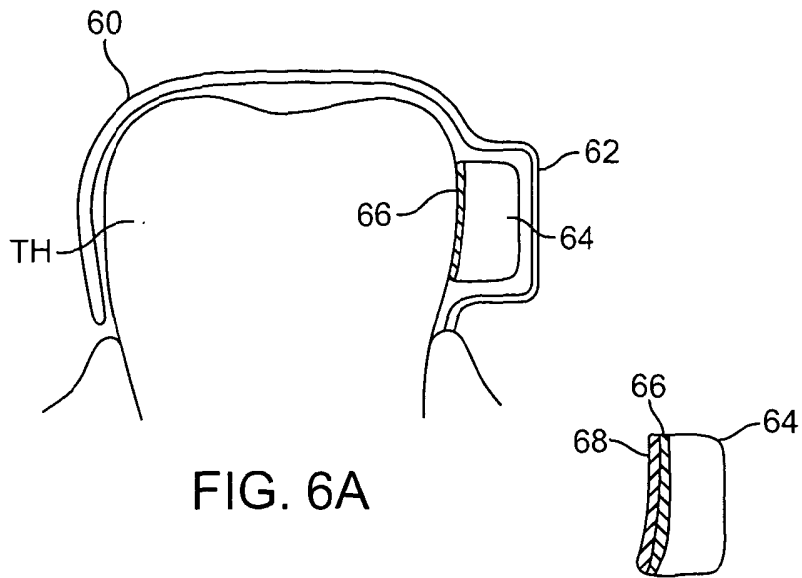

FIG. 6A

FIG. 6B

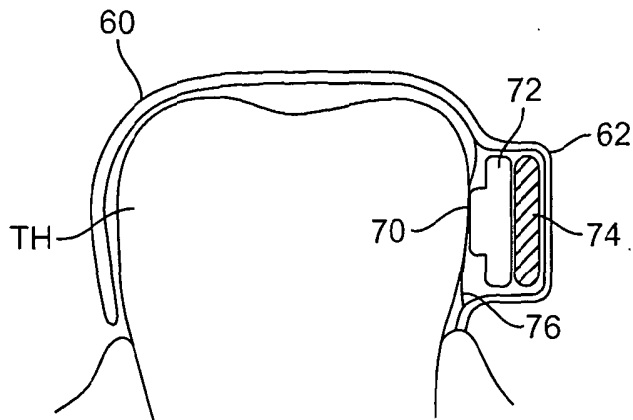

FIG. 7

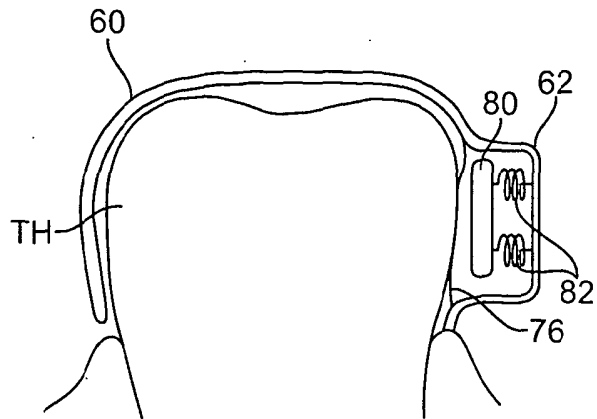

FIG. 8

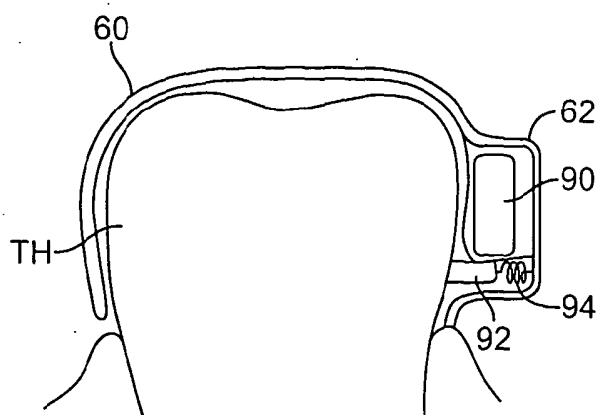

FIG. 9

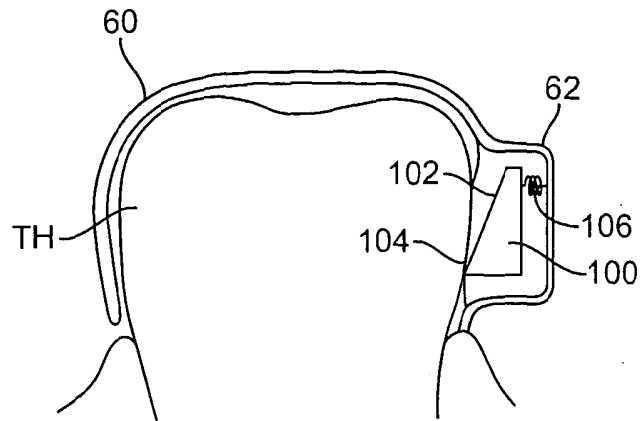

FIG. 10

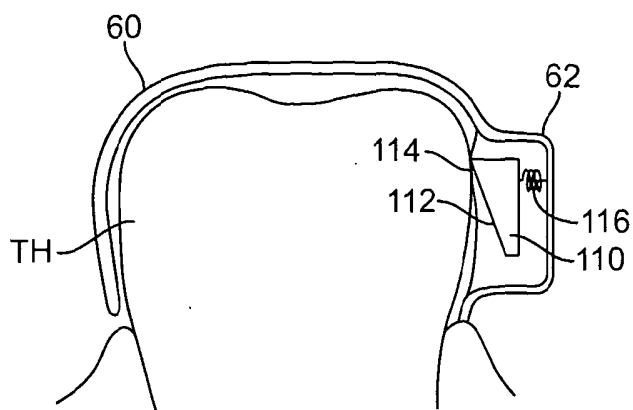

FIG. 11

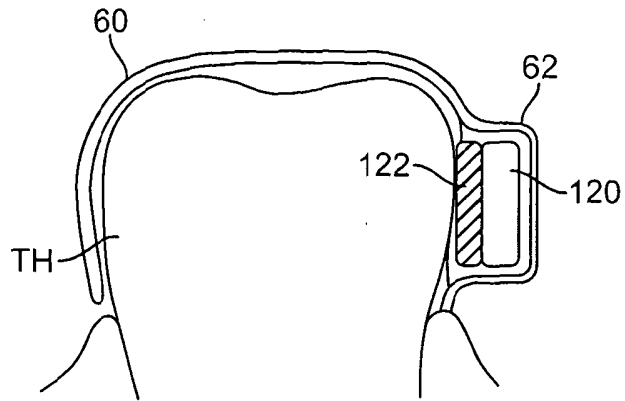

FIG. 12

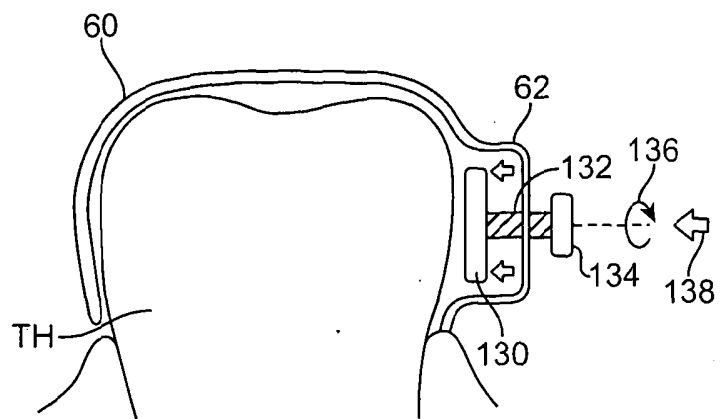

FIG. 13

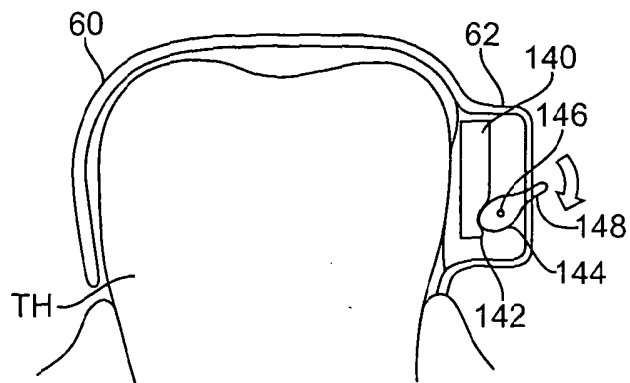

FIG. 14

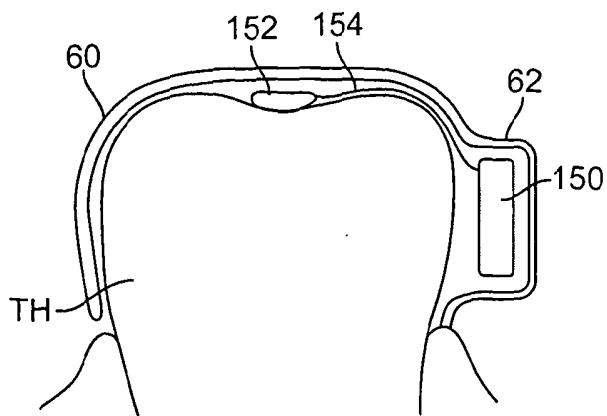

FIG. 15

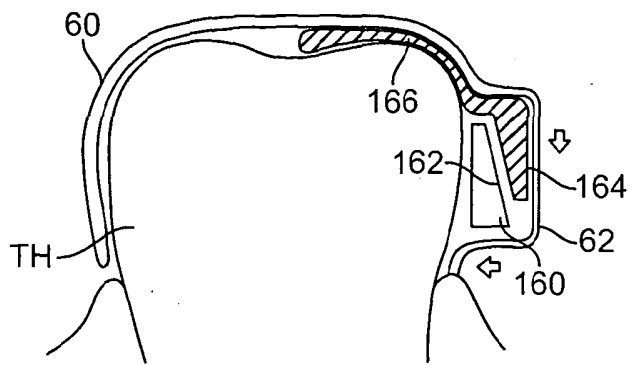

FIG. 16

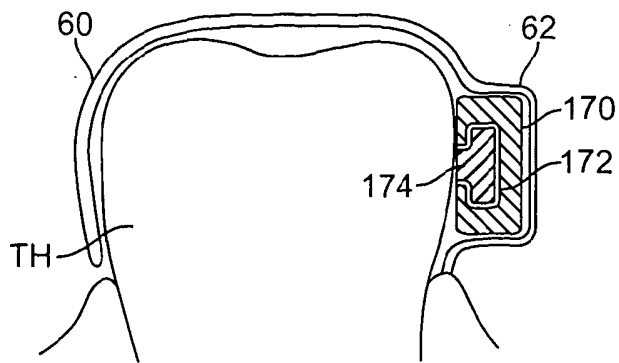

FIG. 17



+

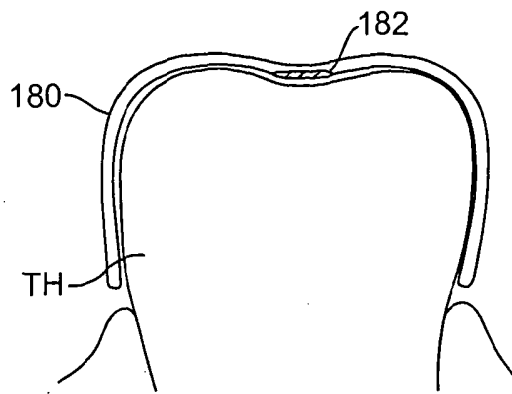

FIG. 18A

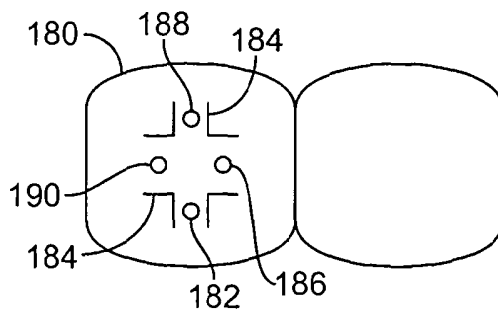

FIG. 18B

+

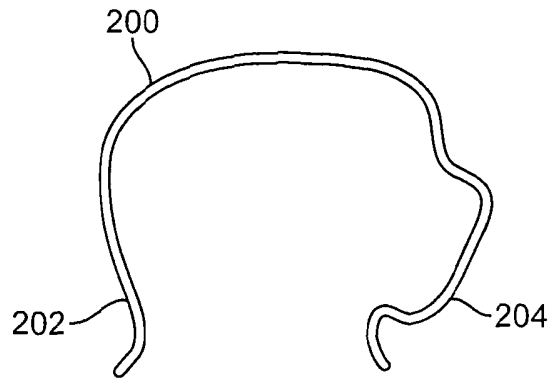

FIG. 19A

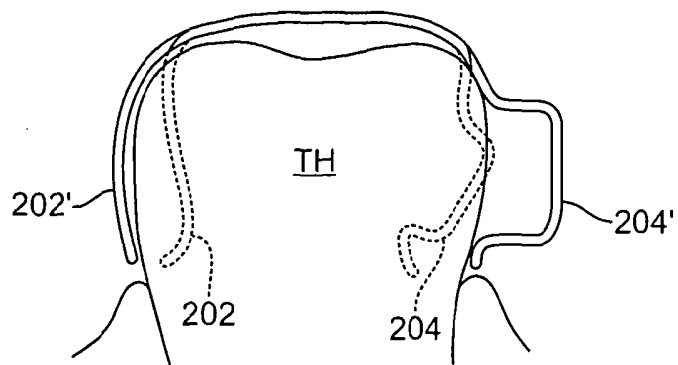

FIG. 19B

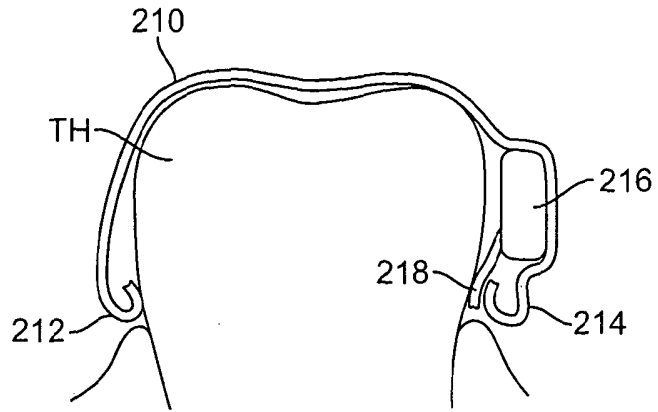

FIG. 20

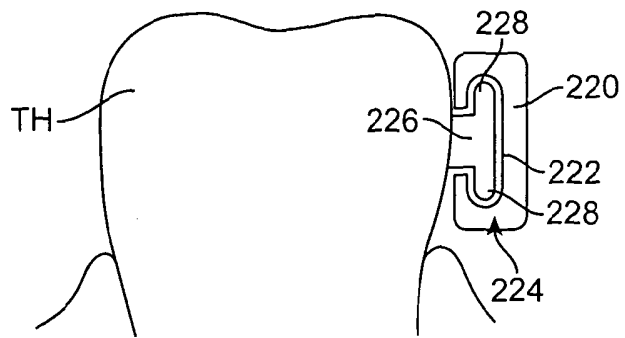

FIG. 21

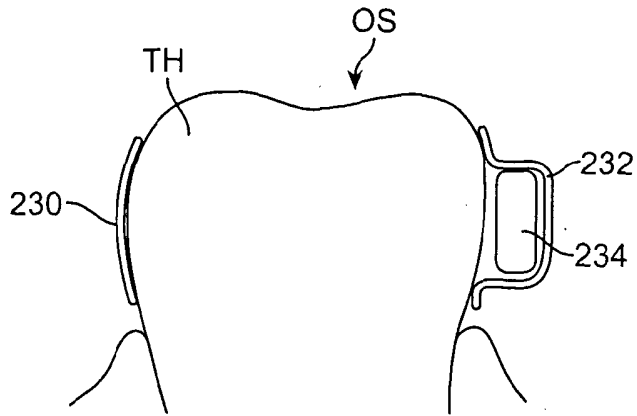

FIG. 22A

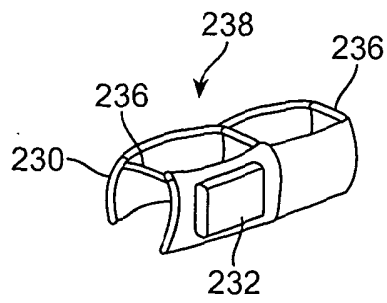

FIG. 22B

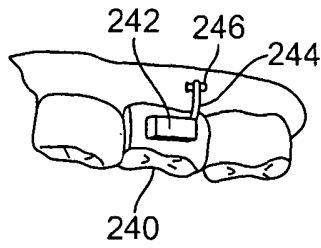

FIG. 23A

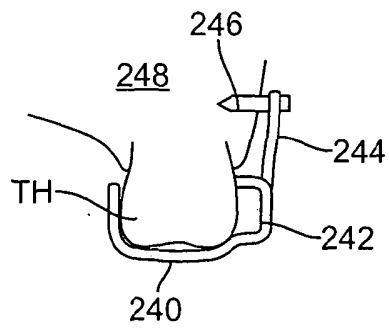

FIG. 23B

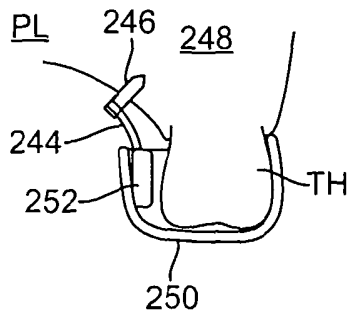

FIG. 24

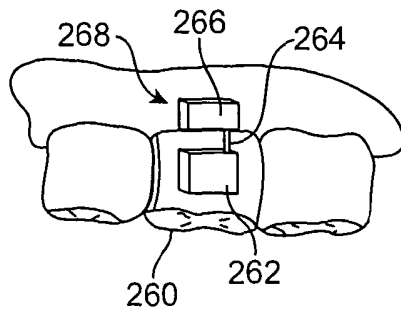

FIG. 25A

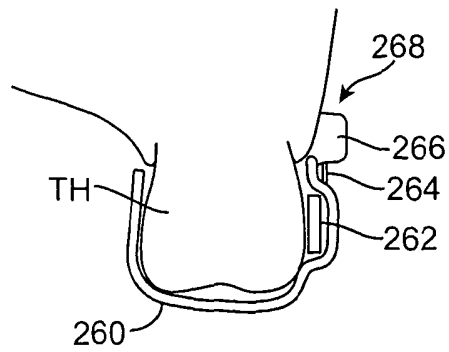

FIG. 25B

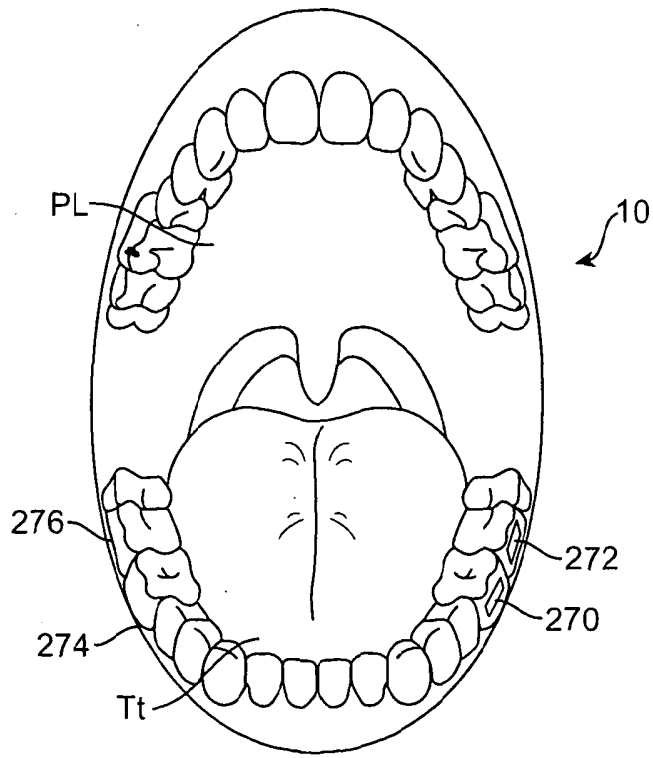

FIG. 26

+

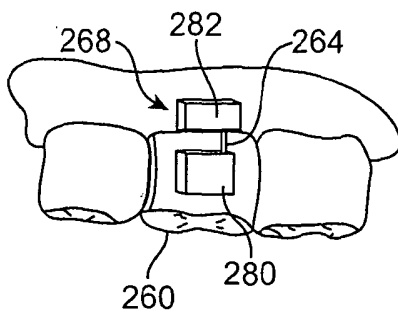

FIG. 27A

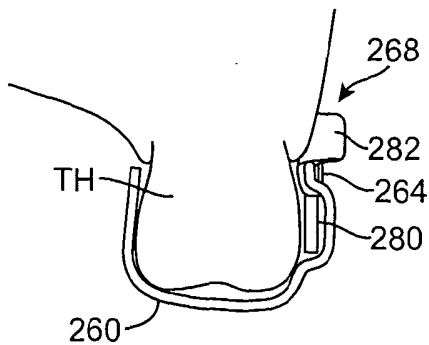

FIG. 27B

+



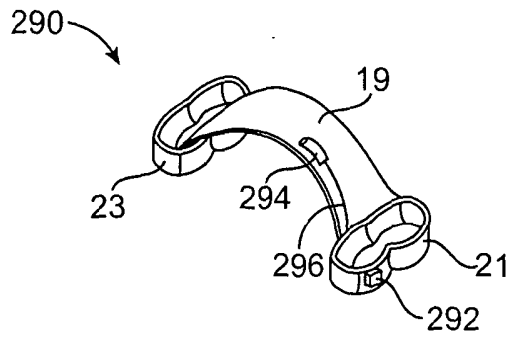

FIG. 28

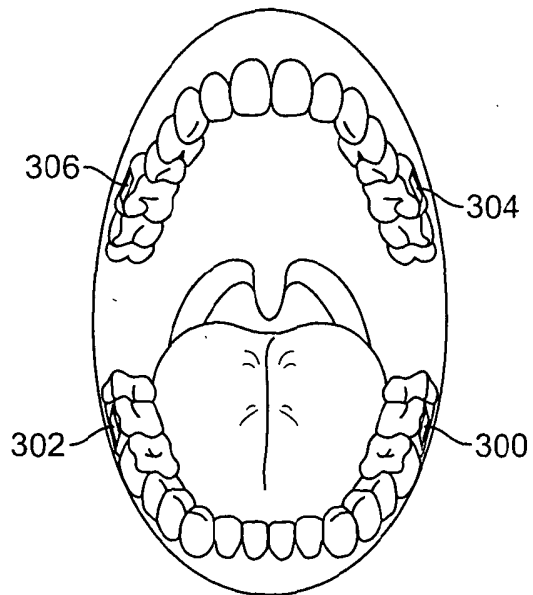

FIG. 29

**SYSTEMS AND METHODS TO PROVIDE COMMUNICATION,  
POSITIONING AND MONITORING OF USER STATUS**

**BACKGROUND**

[0001] In most countries special forces (SF) is a generic term for highly-trained military teams/units that conduct specialized operations such as reconnaissance, unconventional warfare, and counter-terrorism actions. (In the United States, the term Special Operations Forces (SOF) is used instead of special forces to refer to the aforementioned units because Special Forces refers to a specific unit, the United States Army Special Forces aka "Green Berets".)

[0002] Special operations forces conduct worldwide special operations in peace and war in support of regional combatant commanders, ambassadors, and the National Command Authorities. Special operations forces serve three strategic purposes that are increasingly important in the current and future international environment. First, they offer a range of options to decision makers confronting crises and conflicts below the threshold of war, such as terrorism, insurgency, and sabotage. Second, they are force multipliers for major conflicts, increasing the effectiveness and efficiency of the military effort. They are also the forces of choice in situations requiring regional orientation and cultural and political sensitivity, including military-to-military contacts and noncombatant missions like humanitarian assistance, security assistance, and peacekeeping operations.

[0003] These forces engage in high risk jobs and have special needs for navigating in unfamiliar terrain, for communicating and coordinating with team members, and protection from gunshots and explosions. Conventional approaches include bullet-proof glass, concrete and steel building structures, armored cars, bullet-proof jackets, and others. The particular avenue taken depends on whether the person is stationary, located in a vehicle, located within a building, or is required to maintain mobility outside the confines of any specific stationary structure.

## SUMMARY

- [0004] In one aspect, a communication apparatus includes a bone conduction communication apparatus with a housing having a shape which is conformable to at least a portion of at least one tooth of a user; a transceiver mounted in the housing; and a transducer disposed within or upon the housing and in vibratory communication with a surface of the at least one tooth to transmit sound through the at least one tooth. A positioning system is provided to transmit navigational instructions to the transceiver to be delivered to the transducer; and a long range secure communication radio links the transceiver with a remote person.
- 10 [0005] Implementations of the above aspect may include one or more of the following. A hearing protection unit can be inserted or positioned within or in proximity to the user's ear. The protection unit can be a noise cancellation device or can be a simple plug to block out sound and to focus hearing on bone-conducted sound rather than sound coming through the ear canal. The positioning system and the transducer provide turn by turn audio navigation instructions to the user. The long range secure communication radio transmits the user's position to a remote monitoring center. The long range secure communication radio is interoperable with a plurality of tactical radios and intercom system. The long range secure communication radio can be a plurality of tactical radios and an intercom system. A user interface allows the user to change radio channel and radio volume. The user interface can be mounted on a weapon rail to enable the user to control the channel and volume without removing the user's hand. The user interface can be voice activated to enable hands-free operation. A motion sensor to detect a force imposed on the user may be included as part of the present invention. A protective vest can be worn by the user and actuated by the motion sensor. The protective vest can inflate when the motion sensor detects an incoming force. For example, the protective vest is actuated by a blast. A helmet can be worn, and a linkage can be used with the vest and a helmet, the linkage being hardened when the blast is detected to protect the user's neck. A controller can be used with the transceiver to disable the communication apparatus when worn by an unauthorized user. The motion sensor captures a blast vector comprising direction and magnitude of a blast.
- 20 25 30 [0006] In another aspect, a bone conduction communication apparatus includes a housing having a shape which is conformable to at least a portion of at least one tooth of a

user; a motion sensor to detect a force imposed on the user; an actuatable transducer disposed within or upon the housing and in vibratory communication with a surface of the at least one tooth; and a wireless satellite transceiver coupled to the motion sensor to communicate the force and coupled to the transducer to provide received sound to the user and to support  
5 global communication for the user.

[0007] In yet another aspect, an electronic and transducer device can be attached, adhered, or otherwise embedded into or upon a removable oral appliance or other oral device to form a two-way communication assembly. The device contains a motion sensor to detect external forces imposed on the user such as an explosion, for example. The information is  
10 stored for medical treatment, among others. In another embodiment, the device provides an electronic and transducer device that can be attached, adhered, or otherwise embedded into or upon a removable oral appliance or other oral device to form a medical tag containing patient identifiable information. Such an oral appliance may be a custom-made device fabricated from a thermal forming process utilizing a replicate model of a dental structure obtained by  
15 conventional dental impression methods. The electronic and transducer assembly may receive incoming sounds either directly or through a receiver to process and amplify the signals and transmit the processed sounds via a vibrating transducer element coupled to a tooth or other bone structure, such as the maxillary, mandibular, or palatine bone structure.

[0008] The system reduces paperwork; allows for the collection of more complete  
20 patient information, eliminates redundant data entry, increases responsiveness to medical situations and enables healthcare providers to make certain all patient episodes are captured and recorded no matter the environment. The system provides a standard of care to soldiers (as used herein, soldiers also include SOF) by providing access to previously unavailable information. The system is a multi-purpose medical platform that is rugged, wireless and  
25 secure. The system provides commanders with real time visibility of their readiness status and provides support for medical command and control, telemedicine and medical informatics applications across the continuum of the entire spectrum of military medical operations but especially for the first responder and far forward medical facilities. With soldiers deployed in many different parts of the world, the system allows medical professionals to capture patient  
30 episodes anywhere, anytime, and ensure complete patient information is recorded and transferred to the soldier's medical record at home.

[0009] Certain embodiments of the system automatically inflates Kevlar coated jackets and helmets to protect the user from the forces of blasts or explosions. These embodiments receive the output of the motion sensors and detect the presence of blasts/explosions and cause the vests/helmets to become hardened to protect the wearer from the blasts/explosions. The system can provide an automated introduction of a protective, inflatable shield between the concussive force of a bomb blast or the impact energy of a projectile, and the body of the person at which it is directed.

[0010] The system is uniquely tailored to the individual and can contain tamper-proof electronics that disable the system if the system is removed from the authorized user and tampered with in order to be used by an unauthorized user. In this manner, the system is highly secured. Due to the security, the system can provide a dental identification means which is retained on the individual and thus is less subject to destruction, loss, forgetfulness, or any of the numerous other problems.

## BRIEF DESCRIPTION OF THE DRAWINGS

- [0011] Fig. 1A shows a first embodiment of an exemplary communication device and/or medical monitoring device.
- [0012] Fig. 1B shows a second embodiment of an exemplary communication device and/or medical monitoring device.
- [0013] Fig. 1C shows a third embodiment of an exemplary communication device and/or medical monitoring device.
- [0014] Fig. 1D illustrates the dentition of a patient's teeth and one variation of a two-way communication device which is removably placed upon or against the patient's tooth or teeth as a removable oral appliance.
- [0015] Fig. 2A illustrates a perspective view of the lower teeth showing one exemplary location for placement of the removable oral appliance two-way communication device.
- [0016] Fig. 2B illustrates another variation of the removable oral appliance in the form of an appliance which is placed over an entire row of teeth in the manner of a mouthguard.
- [0017] Fig. 2C illustrates another variation of the removable oral appliance which is supported by an arch.
- [0018] Fig. 2D illustrates another variation of an oral appliance configured as a mouthguard.
- [0019] Fig. 3 illustrates a detail perspective view of the oral appliance positioned upon the patient's teeth utilizable in combination with a transmitting assembly external to the mouth and wearable by the patient in another variation of the device.
- [0020] Fig. 4 shows an illustrative configuration of the individual components in a variation of the oral appliance device having an external transmitting assembly with a receiving and transducer assembly within the mouth.
- [0021] Fig. 5 shows an illustrative configuration of another variation of the device in which the entire assembly is contained by the oral appliance within the user's mouth.
- [0022] Fig. 6A shows a partial cross-sectional view of an oral appliance placed upon a tooth with an electronics/transducer assembly adhered to the tooth surface via an adhesive.
- [0023] Fig. 6B shows a partial cross-sectional view of a removable backing adhered onto an adhesive surface.

- [0024] Fig. 7 shows a partial cross-sectional view of another variation of an oral appliance placed upon a tooth with an electronics/transducer assembly pressed against the tooth surface via an osmotic pouch.
- [0025] Fig. 8 shows a partial cross-sectional view of another variation of an oral appliance placed upon a tooth with an electronics/transducer assembly pressed against the tooth surface via one or more biasing elements.
- [0026] Fig. 9 illustrates another variation of an oral appliance having an electronics assembly and a transducer assembly separated from one another within the electronics and transducer housing of the oral appliance.
- 10 [0027] Figs. 10 and 11 illustrate additional variations of oral appliances in which the electronics and transducer assembly are maintainable against the tooth surface via a ramped surface and a biasing element.
- [0028] Fig. 12 shows yet another variation of an oral appliance having an interfacing member positioned between the electronics and/or transducer assembly and the tooth surface.
- 15 [0029] Fig. 13 shows yet another variation of an oral appliance having an actuatable mechanism for urging the electronics and/or transducer assembly against the tooth surface.
- [0030] Fig. 14 shows yet another variation of an oral appliance having a cam mechanism for urging the electronics and/or transducer assembly against the tooth surface.
- [0031] Fig. 15 shows yet another variation of an oral appliance having a separate transducer mechanism positionable upon the occlusal surface of the tooth for transmitting vibrations.
- 20 [0032] Fig. 16 illustrates another variation of an oral appliance having a mechanism for urging the electronics and/or transducer assembly against the tooth surface utilizing a bite-actuated mechanism.
- 25 [0033] Fig. 17 shows yet another variation of an oral appliance having a composite dental anchor for coupling the transducer to the tooth.
- [0034] Figs. 18A and 18B show side and top views, respectively, of an oral appliance variation having one or more transducers which may be positioned over the occlusal surface of the tooth.
- 30 [0035] Figs. 19A and 19B illustrate yet another variation of an oral appliance made from a shape memory material in its pre-formed relaxed configuration and its deformed

configuration when placed over or upon the patient's tooth, respectively, to create an interference fit.

5 [0036] Fig. 20 illustrates yet another variation of an oral appliance made from a pre-formed material in which the transducer may be positioned between the biased side of the oral appliance and the tooth surface.

[0037] Fig. 21 illustrates a variation in which the oral appliance may be omitted and the electronics and/or transducer assembly may be attached to a composite dental anchor attached directly to the tooth surface.

10 [0038] Figs. 22A and 22B show partial cross-sectional side and perspective views, respectively, of another variation of an oral appliance assembly having its occlusal surface removed or omitted for patient comfort.

[0039] Figs. 23A and 23B illustrate perspective and side views, respectively, of an oral appliance which may be coupled to a screw or post implanted directly into the underlying bone, such as the maxillary or mandibular bone.

15 [0040] Fig. 24 illustrates another variation in which the oral appliance may be coupled to a screw or post implanted directly into the palate of a patient.

[0041] Figs. 25A and 25B illustrate perspective and side views, respectively, of an oral appliance which may have its transducer assembly or a coupling member attached to the gingival surface to conduct vibrations through the gingival tissue and underlying bone.

20 [0042] Fig. 26 illustrates an example of how multiple oral appliance two-way communication assemblies or transducers may be placed on multiple teeth throughout the patient's mouth.

[0043] Figs. 27A and 27B illustrate perspective and side views, respectively, of an oral appliance (similar to a variation shown above) which may have a microphone unit  
25 positioned adjacent to or upon the gingival surface to physically separate the microphone from the transducer to attenuate or eliminate feedback.

[0044] Fig. 28 illustrates another variation of a removable oral appliance supported by an arch and having a microphone unit integrated within the arch.

30 [0045] Fig. 29 shows yet another variation illustrating at least one microphone and optionally additional microphone units positioned around the user's mouth and in wireless communication with the electronics and/or transducer assembly.



## DESCRIPTION

[0046] As shown in Fig. 1A, an exemplary two way hands-free communication and position determination monitoring device is shown. In Fig. 1A, the communication and monitoring device includes a bone conduction communication apparatus 1 with a housing having a shape which is conformable to at least a portion of at least one tooth of a user. The bone conduction communication apparatus 1 includes a short-range, low power transceiver mounted in the housing; and a transducer disposed within or upon the housing and in vibratory communication with a surface of the at least one tooth to transmit sound through the at least one tooth. A positioning system 2 is provided to transmit navigational instructions to the transceiver to be delivered to the transducer; and a long range secure communication radio 3A links the transceiver with a remote server 5A and/or a remote person for voice communication.

[0047] To protect the user from loud noises such as gun noises, a hearing protection unit can be inserted or positioned within or in proximity to the user's ear. The protection unit can be a noise cancellation device or can be a simple plug to block out sound and to focus hearing on bone-conducted sound rather than sound coming through the ear canal.

[0048] During missions, the positioning system 2 sends turn by turn audio navigation instructions to the user through the short-range low power transceiver. The long range secure communication radio 3A transmits the user's position to a remote monitoring center that can include people as well as communication servers. The long range secure communication radio 3A is interoperable with a plurality of tactical radios and intercom system. The long range secure communication radio 3A can be a plurality of tactical radios and an intercom system. A user interface allows the user to change radio channel and radio volume. The user interface can be mounted on a weapon rail to enable the user to control the channel and volume without removing the user's hand. The user interface can be voice activated to enable hands-free operation. A motion sensor to detect a force imposed on the user may be included as part of the present invention. As shown in Fig. 1C, a protective vest can be worn by the user and actuated by the motion sensor. The protective vest can inflate when the motion sensor detects an incoming force. For example, the protective vest is actuated by a blast. A helmet can be worn, and a linkage can be used with the vest and a helmet, the linkage being hardened when the blast is detected to protect the user's neck. A controller can be used with the transceiver

to disable the communication apparatus when worn by an unauthorized user. The motion sensor captures a blast vector comprising direction and magnitude of a blast.

5 [0049] In the embodiment of Fig. 1C, the device 1 is mounted in the user's mouth. More details on the intraoral device 1 are discussed below. The device 1 can communicate with the positioning device 2 such as GPS, GLONASS, or Galileo. Additionally, one or more body mounted sensors can be adjacent the positioning device 2 and they can communicate with other electronics through a short range personal area network (PAN). The device 1 can also communicate with an attention device 4 such as a flashing light, among others. In case of an emergency with poor visibility, the attention device 4 can be activated to identify the  
10 wearer so that assistance can be rendered quickly. The device 1, the sensor 2 and attention device 4 communicates with a long range transceiver 3A. In the embodiment of Fig. 1A, the system communicates through a remote server 5A over a long range wireless area network such as WiMAX. In Fig. 1B, a transceiver 3B is a cellular transceiver that communicates with cellular towers 5B, for example.

15 [0050] In one embodiment, the device 1 provides an electronic and transducer device that can be attached, adhered, or otherwise embedded into or upon a removable oral appliance or other oral device to form a medical tag containing patient identifiable information. Such an oral appliance may be a custom-made device fabricated from a thermal forming process utilizing a replicate model of a dental structure obtained by conventional dental impression  
20 methods. The electronic and transducer assembly may receive incoming sounds either directly or through a receiver to process and amplify the signals and transmit the processed sounds via a vibrating transducer element coupled to a tooth or other bone structure, such as the maxillary, mandibular, or palatine bone structure.

[0051] In a military application as shown in Fig. 1C, the device 1 can include sensors  
25 that detect chemicals present in the soldier's saliva and provide medical information on the soldier. Additionally, in certain embodiments, the device 1 can also sense heart rate, EKG, and other bio-signals that can be picked up within the mouth. Additionally, the device 1 can communicate with the medical data collection modules that can collect heart rate, EKG, respiration rate, and other vital signs or medical information. The device 1 can communicate  
30 with the GPS 2 and sensor modules through various short range radios such as a Bluetooth radio, for example, or through body conduction transceivers, among others.

[0052] During operation, the GPS can be used to provide detailed navigation for the soldier.

[0053] An exemplary process to use the bone-conduction two way communication during a military mission can be as follows:

5 Remind user to use ear protection device upon power up.

Periodically collect position coordinates from team members, verbally guide the user to destination in coordination with team members, and display the team member position for viewing.

Capture and respond to commands.

- 10
- 1) User can verbally request changes to radio communication channels or volume settings, for example.
  - 2) Rail mounted buttons can receive user actuations for a particular operation where silence is required.

[0054] In another embodiment, the device 1 is custom-fit to the user and will not be  
15 usable by another individual if transplanted to another user such as through hostile action by an enemy or through an intentional action by the wearer. This will be done by the fact that it is custom-fit to the user. Further, in one embodiment, if the device is tampered with, anti-tampering circuitry in the device 1 will render the device non-functional.

[0055] The device 1 can also communicate with a long range transceiver such as a  
20 short-wave transceiver 3A, a cellular telephone transceiver 3B, or a satellite transceiver 3C. Such transceivers can be provided within the device 1, or alternatively, can be body worn. In the embodiment of Fig. 1C, the satellite transceiver 3C is positioned on a belt worn by the soldier. The satellite transceiver 3C communicates with the device 1 through the short range radio such as Bluetooth, for example.

25 [0056] Although custom-fitted devices are shown and described, such devices are not limited to being custom-fitted. Accordingly, these devices may also include those which are not manufactured to conform to the particular anatomy of any soldier such that, e.g., dental impressions, are rendered unnecessary for the manufacture and use of the device as contemplated herein. For instance, in one example, one or more biasing elements (as further  
30 described herein) may be positioned on or within the device such that the device exerts a

pressure against one or more teeth of the soldier (or other user) thereby facilitating secure contact of the device to the user. Moreover, use or applications of these devices described herein are not limited to soldiers or other military personnel but may also be utilized by any number of other users, including, e.g., law enforcement personnel, emergency personnel, etc.

5 [0057] The device 1 can contain a motion sensor such as an accelerometer. The motion sensor can store information on external forces that are imposed on the user such as the forces arising from a bomb blast. The accelerometer measures the total specific external force on the sensor. The accelerometer can be a micro electro-mechanical system (MEMS) device that includes a suspended cantilever beam or proof mass (also known as seismic mass) with deflection sensing and circuitry. Other methods of building MEMS based accelerometers are known.

[0058] In one embodiment, the accelerometer is a 3 axis accelerometer that can capture the blast vector including direction and magnitude of the force. The blast vector is stored in memory and can also be transmitted to a remote monitoring center. For example, 15 the motion sensor output can be provided to the long range transceiver for remote monitoring of the well being of the user. If a blast is detected, medical assistance can be sent to save the user from harm. In another embodiment, historical blast vector information can be analyzed for injury trend analysis and subsequent treatment even if the soldier reports no immediate medical injury.

20 [0059] In another embodiment, the accelerometer output is used to activate a reactive personnel protection system which, upon detecting the presence of a destructive force or object, interposes a protective shield between personnel under attack and the force in an almost instantaneous fashion. To protect against a concussive blast triggered by a bomb explosion, the output of the accelerometer triggers a rapid inflation of a vest 7A with an air bag worn by the user. The air bag can be fabricated from Kevlar® or similar materials. The 25 air bag is rapidly inflated and interposed between a projectile or a concussive force and the person to be protected so as to either deflect the projectile or reduce the effects of the concussive force.

[0060] In another embodiment, the airbag can have a linkage 7C to a helmet 7B and 30 the linkage is automatically inflated when the accelerometer senses the destructive force or

object. When inflated, the vest 7A, the linkage 7C and the helmet 7B is hardened to protect the user from neck injury and other bodily harm(s).

[0061] The accelerometer senses an explosion or a bullet by sensing rapid changes in acceleration and/or air pressure (e.g. the concussive wave front which accompanies an explosion). Other devices, such as magnetostrictive transducers, ultrasonic transducers, accelerometers, and other mechanical and/or electro-mechanical sensors can also be applied to sense the occurrence of a concussive explosion.

[0062] The forces of the concussive explosion and/or vital signs of the user can be automatically transmitted to a remote monitoring center that can dispatch help if required. An exemplary process to collect medical information from the patient and for supporting bone-conduction two way communication can be as follows:

Periodically collect medical information

Check to see if the soldier is using the long range transceiver for talking

If long range transceiver is not used for talking, upload medical history of the soldier to a remote computer over the long range transceiver

Remote computer detects if the medical data falls outside of an acceptable range that requires medical intervention

If medical intervention is required, the remote computer alerts the soldier's commander for action to assist the soldier

Self-help instructions can be sent through the satellite transceiver to the bone conduction communication device 1

[0063] In one embodiment, the medical data would include soldier identification, triage status, condition, and treatment. The data would be routed via the satellite transceiver to a Command Post where it is processed, stored, relayed to the Internet, and moved back to devices on the field. As a result, data on casualties would be accessible immediately for operational use by other soldiers, medics, responders, incident commanders and even receiving hospitals that can help the soldier. Real-time information regarding victims and their status is critical to the overall management of field medical care. Medical command can then coordinate timely information on the number of casualties and their needs with the

known availability of resources, such as on-scene providers, ambulance locations, and area hospital capacities. Real-time information is also provided for determining the appropriate patient destination, depending on the type of injuries and the capabilities of the receiving facilities.

5 [0064] In another embodiment, the remote computer can support a BATTLEFIELD MEDICAL INFORMATION SYSTEMS TACTICAL-JOINT (BMIST-J) for enabling military providers to record, store, retrieve and transfer medical records to the DoD's Clinical Data Repository by synchronizing the received data. The system supports digital versions of the DD 1380 (field medical card) and SF 600 (chronological medical record of care).

10 Diagnostic and treatment decision aids are provided by the system. The data captured by the device 1 is also Personal Information Carrier (PIC) compatible. The system provides a secure, legible, electronic records of battlefield treatments, contributes to a comprehensive, life-long medical history, and facilitates medical surveillance.

[0065] Turning now to more details on the device 1, as shown in Fig. 1D, a patient's mouth and dentition 10 is illustrated showing one possible location for removably attaching two-way communication assembly 14 upon or against at least one tooth, such as a molar 12. The patient's tongue TG and palate PL are also illustrated for reference. An electronics and/or transducer assembly 16 may be attached, adhered, or otherwise embedded into or upon the assembly 14, as described below in further detail.

20 [0066] Fig. 2A shows a perspective view of the patient's lower dentition illustrating the two-way communication assembly 14 comprising a removable oral appliance 18 and the electronics and/or transducer assembly 16 positioned along a side surface of the assembly 14. In this variation, oral appliance 18 may be fitted upon two molars 12 within tooth engaging channel 20 defined by oral appliance 18 for stability upon the patient's teeth, although in  
25 other variations, a single molar or tooth may be utilized. Alternatively, more than two molars may be utilized for the oral appliance 18 to be attached upon or over. Moreover, electronics and/or transducer assembly 16 is shown positioned upon a side surface of oral appliance 18 such that the assembly 16 is aligned along a buccal surface of the tooth 12; however, other surfaces such as the lingual surface of the tooth 12 and other positions may also be utilized.  
30 The figures are illustrative of variations and are not intended to be limiting; accordingly, other configurations and shapes for oral appliance 18 are intended to be included herein.

[0067] Fig. 2B shows another variation of a removable oral appliance in the form of an appliance 15 which is placed over an entire row of teeth in the manner of a mouthguard. In this variation, appliance 15 may be configured to cover an entire bottom row of teeth or alternatively an entire upper row of teeth. In additional variations, rather than covering the entire rows of teeth, a majority of the row of teeth may be instead be covered by appliance 15. Assembly 16 may be positioned along one or more portions of the oral appliance 15.

[0068] Fig. 2C shows yet another variation of an oral appliance 17 having an arched configuration. In this appliance, one or more tooth retaining portions 21, 23, which in this variation may be placed along the upper row of teeth, may be supported by an arch 19 which may lie adjacent or along the palate of the user. As shown, electronics and/or transducer assembly 16 may be positioned along one or more portions of the tooth retaining portions 21, 23. Moreover, although the variation shown illustrates an arch 19 which may cover only a portion of the palate of the user, other variations may be configured to have an arch which covers the entire palate of the user.

[0069] Fig. 2D illustrates yet another variation of an oral appliance in the form of a mouthguard or retainer 25 which may be inserted and removed easily from the user's mouth. Such a mouthguard or retainer 25 may be used in sports where conventional mouthguards are worn; however, mouthguard or retainer 25 having assembly 16 integrated therein may be utilized by persons, hearing impaired or otherwise, who may simply hold the mouthguard or retainer 25 via grooves or channels 26 between their teeth for receiving instructions remotely and communicating over a distance.

[0070] Generally, the volume of electronics and/or transducer assembly 16 may be minimized so as to be unobtrusive and as comfortable to the user when placed in the mouth. Although the size may be varied, a volume of assembly 16 may be less than 800 cubic millimeters. This volume is, of course, illustrative and not limiting as size and volume of assembly 16 and may be varied accordingly between different users.

[0071] Moreover, removable oral appliance 18 may be fabricated from various polymeric or a combination of polymeric and metallic materials using any number of methods, such as computer-aided machining processes using computer numerical control (CNC) systems or three-dimensional printing processes, e.g., stereolithography apparatus (SLA), selective laser sintering (SLS), and/or other similar processes utilizing three-

dimensional geometry of the patient's dentition, which may be obtained via any number of techniques. Such techniques may include use of scanned dentition using intra-oral scanners such as laser, white light, ultrasound, mechanical three-dimensional touch scanners, magnetic resonance imaging (MRI), computed tomography (CT), other optical methods, etc.

5 [0072] In forming the removable oral appliance 18, the appliance 18 may be optionally formed such that it is molded to fit over the dentition and at least a portion of the adjacent gingival tissue to inhibit the entry of food, fluids, and other debris into the oral appliance 18 and between the transducer assembly and tooth surface. Moreover, the greater surface area of the oral appliance 18 may facilitate the placement and configuration of the assembly 16 onto the appliance 18.

10 [0073] Additionally, the removable oral appliance 18 may be optionally fabricated to have a shrinkage factor such that when placed onto the dentition, oral appliance 18 may be configured to securely grab onto the tooth or teeth as the appliance 18 may have a resulting size slightly smaller than the scanned tooth or teeth upon which the appliance 18 was formed. The fitting may result in a secure interference fit between the appliance 18 and underlying dentition.

15 [0074] In one variation, with assembly 14 positioned upon the teeth, as shown in Fig. 3, an extra-buccal transmitter assembly 22 located outside the patient's mouth may be utilized to receive auditory signals for processing and transmission via a wireless signal 24 to the electronics and/or transducer assembly 16 positioned within the patient's mouth, which may then process and transmit the processed auditory signals via vibratory conductance to the underlying tooth and consequently to the patient's inner ear.

20 [0075] The transmitter assembly 22, as described in further detail below, may contain a microphone assembly as well as a transmitter assembly and may be configured in any number of shapes and forms worn by the user, such as a watch, necklace, lapel, phone, belt-mounted device, etc.

25 [0076] Fig. 4 illustrates a schematic representation of one variation of two-way communication assembly 14 utilizing an extra-buccal transmitter assembly 22, which may generally comprise microphone 30 for receiving sounds and which is electrically connected to processor 32 for processing the auditory signals. The assembly 14 includes motion sensor 31 whose output is connected to processor 32. Motion sensor 31 can be a three axis



accelerometer, among others. For small size, the accelerometer can be a MEMS accelerometer. Processor 32 may be connected electrically to transmitter 34 for transmitting the processed signals to the electronics and/or transducer assembly 16 disposed upon or adjacent to the user's teeth. The microphone 30 and processor 32 may be configured to detect and process auditory signals in any practicable range, but may be configured in one variation to detect auditory signals ranging from, e.g., 250 Hertz to 20,000 Hertz.

[0077] With respect to microphone 30, a variety of various microphone systems may be utilized. For instance, microphone 30 may be a digital, analog, and/or directional type microphone. Such various types of microphones may be interchangeably configured to be utilized with the assembly, if so desired.

[0078] Power supply 36 may be connected to each of the components in transmitter assembly 22 to provide power thereto. The transmitter signals 24 may be in any wireless form utilizing, e.g., radio frequency, ultrasound, microwave, Blue Tooth® (BLUETOOTH SIG, INC., Bellevue, WA), etc. for transmission to assembly 16. Assembly 22 may also optionally include one or more input controls 28 that a user may manipulate to adjust various acoustic parameters of the electronics and/or transducer assembly 16, such as acoustic focusing, volume control, filtration, muting, frequency optimization, sound adjustments, and tone adjustments, etc.

[0079] The signals transmitted 24 by transmitter 34 may be received by electronics and/or transducer assembly 16 via receiver 38, which may be connected to an internal processor for additional processing of the received signals. The received signals may be communicated to transducer 40, which may vibrate correspondingly against a surface of the tooth to conduct the vibratory signals through the tooth and bone and subsequently to the middle ear to facilitate hearing of the user. Transducer 40 may be configured as any number of different vibratory mechanisms. For instance, in one variation, transducer 40 may be an electromagnetically actuated transducer. In other variations, transducer 40 may be in the form of a piezoelectric crystal having a range of vibratory frequencies, e.g., between 250 to 4000 Hz.

[0080] Power supply 42 may also be included with assembly 16 to provide power to the receiver, transducer, and/or processor, if also included. Although power supply 42 may be a simple battery, replaceable or permanent, other variations may include a power supply 42

which is charged by inductance via an external charger. Additionally, power supply 42 may alternatively be charged via direct coupling to an alternating current (AC) or direct current (DC) source. Other variations may include a power supply 42 which is charged via a mechanical mechanism, such as an internal pendulum or slidable electrical inductance charger  
5 as known in the art, which is actuated via, e.g., motions of the jaw and/or movement for translating the mechanical motion into stored electrical energy for charging power supply 42.

[0081] In another variation of assembly 16, rather than utilizing an extra-buccal transmitter, two-way communication assembly 50 may be configured as an independent assembly contained entirely within the user's mouth, as shown in Fig. 5. Accordingly,  
10 assembly 50 may include an internal microphone 52 in communication with an on-board processor 54. Internal microphone 52 may comprise any number of different types of microphones, as described above. Processor 54 may be used to process any received auditory signals for filtering and/or amplifying the signals and transmitting them to transducer 56, which is in vibratory contact against the tooth surface. Power supply 58, as described above,  
15 may also be included within assembly 50 for providing power to each of the components of assembly 50 as necessary.

[0082] In order to transmit the vibrations corresponding to the received auditory signals efficiently and with minimal loss to the tooth or teeth, secure mechanical contact between the transducer and the tooth is ideally maintained to ensure efficient vibratory  
20 communication. Accordingly, any number of mechanisms may be utilized to maintain this vibratory communication.

[0083] In one variation as shown in Fig. 6A, a partial cross-sectional view of a removable oral appliance 60 is shown placed over or upon a tooth TH. Electronics and/or transducer housing 62 may be seen defined along oral appliance 60 such that housing 62 is aligned or positioned adjacent to a side surface, buccal and/or lingual surface, of the tooth  
25 TH. Housing 62 may provide protection to the electronics and/or transducer assembly from the environment of the mouth.

[0084] An electronics and/or transducer assembly 64 may be simply placed, embedded, or encapsulated within housing 62 for contacting the tooth surface. In this  
30 variation, assembly 64 may be adhered against the tooth surface via an adhesive surface or film 66 such that contact is maintained between the two. As shown in Fig. 6B, a removable

backing 68 may be adhered onto adhesive surface 66 and removed prior to placement upon the tooth surface. In this manner, assembly 64 may be replaced upon the tooth as necessary with additional electronics and/or transducer assemblies.

[0085]        Aside from an adhesive film 66, another alternative may utilize an expandable  
5 or swellable member to ensure a secure mechanical contact of the transducer against the tooth. As shown in Fig. 7, an osmotic patch or expandable hydrogel 74 may be placed between housing 62 and electronics and/or transducer assembly 72. After placement of oral appliance 60, hydrogel 74 may absorb some fluids, either from any surrounding fluid or from a fluid introduced into hydrogel 74, such that hydrogel 74 expands in size to force assembly 72 into  
10 contact against the tooth surface. Assembly 72 may be configured to define a contact surface 70 having a relatively smaller contact area to facilitate uniform contact of the surface 70 against the tooth. Such a contact surface 70 may be included in any of the variations described herein. Additionally, a thin encapsulating layer or surface 76 may be placed over housing 62 between contact surface 70 and the underlying tooth to prevent any debris or  
15 additional fluids from entering housing 62.

[0086]        Another variation is shown in Fig. 8, which shows electronics and/or transducer assembly 80 contained within housing 62. In this variation, one or more biasing elements 82, e.g., springs, pre-formed shape memory elements, etc., may be placed between assembly 80 and housing 62 to provide a pressing force on assembly 80 to urge the device  
20 against the underlying tooth surface, thereby ensuring mechanical contact.

[0087]        In yet another variation, the electronics may be contained as a separate assembly 90 which is encapsulated within housing 62 and the transducer 92 may be maintained separately from assembly 90 but also within housing 62. As shown in Fig. 9, transducer 92 may be urged against the tooth surface via a spring or other biasing element 94  
25 and actuated via any of the mechanisms described above.

[0088]        In other variations as shown in Fig. 10, electronics and/or transducer assembly 100 may be configured to have a ramped surface 102 in apposition to the tooth surface. The surface 102 may be angled away from the occlusal surface of the tooth. The assembly 100 may be urged via a biasing element or spring 106 which forces the ramped surface 102 to  
30 pivot about a location 104 into contact against the tooth to ensure contact for the transducer against the tooth surface.

[0089] Fig. 11 illustrates another similar variation in electronics and/or transducer assembly 110 also having a ramped surface 112 in apposition to the tooth surface. In this variation, the ramped surface 112 may be angled towards the occlusal surface of the tooth. Likewise, assembly 110 may be urged via a biasing element or spring 116 which urges the assembly 110 to pivot about its lower end such that the assembly 110 contacts the tooth surface at a region 114.

[0090] In yet another variation shown in Fig. 12, electronics and/or transducer assembly 120 may be positioned within housing 62 with an interface layer 122 positioned between the assembly 120 and the tooth surface. Interface layer 122 may be configured to conform against the tooth surface and against assembly 120 such that vibrations may be transmitted through layer 122 and to the tooth in a uniform manner. Accordingly, interface layer 122 may be made from a material which attenuates vibrations minimally. Interface layer 122 may be made in a variety of forms, such as a simple insert, an O-ring configuration, etc. or even in a gel or paste form, such as denture or oral paste, etc. Additionally, layer 122 may be fabricated from various materials, e.g., hard plastics or polymeric materials, metals, etc.

[0091] Fig. 13 illustrates yet another variation in which electronics and/or transducer assembly 130 may be urged against the tooth surface via a mechanical mechanism. As shown, assembly 130 may be attached to a structural member 132, e.g., a threaded member or a simple shaft, which is connected through housing 62 to an engagement member 134 located outside housing 62. The user may rotate engagement member 134 (as indicated by rotational arrow 136) or simply push upon member 134 (as indicated by linear arrow 138) to urge assembly 130 into contact against the tooth. Moreover, actuation of engagement member 134 may be accomplished manually within the mouth or through the user's cheek or even through manipulation via the user's tongue against engagement member 134.

[0092] Another variation for a mechanical mechanism is illustrated in Fig. 14. In this variation, electronics and/or transducer assembly 140 may define a portion as an engaging surface 142 for contacting against a cam or lever mechanism 144. Cam or lever mechanism 144 may be configured to pivot 146 such that actuation of a lever 148 extending through housing 62 may urge cam or lever mechanism 144 to push against engaging surface 142 such that assembly 140 is pressed against the underlying tooth surface.

[0093] In yet another variation, the electronics 150 and the transducer 152 may be separated from one another such that electronics 150 remain disposed within housing 62 but transducer 152, connected via wire 154, is located beneath dental oral appliance 60 along an occlusal surface of the tooth, as shown in Fig. 15. In such a configuration, vibrations are transmitted via the transducer 152 through the occlusal surface of the tooth. Additionally, the user may bite down upon the oral appliance 60 and transducer 152 to mechanically compress the transducer 152 against the occlusal surface to further enhance the mechanical contact between the transducer 152 and underlying tooth to further facilitate transmission therethrough.

[0094] In the variation of Fig. 16, another example for a bite-enhanced coupling mechanism is illustrated where electronics and/or transducer assembly 160 defines an angled interface surface 162 in apposition to a correspondingly angled engaging member 164. A proximal end of engaging member 164 may extend through housing 62 and terminate in a pusher member 166 positioned over an occlusal surface of the tooth TH. Once oral appliance 60 is initially placed over tooth TH, the user may bite down or otherwise press down upon the top portion of oral appliance 60, thereby pressing down upon pusher member 166 which in turn pushes down upon engaging member 164, as indicated by the arrow. As engaging member 164 is urged downwardly towards the gums, its angled surface may push upon the corresponding and oppositely angled surface 162 to urge assembly 160 against the tooth surface and into a secure mechanical contact.

[0095] In yet another variation, an electronics and/or transducer assembly 170 may define a channel or groove 172 along a surface for engaging a corresponding dental anchor 174, as shown in Fig. 17. Dental anchor 174 may comprise a light-curable acrylate-based composite material adhered directly to the tooth surface. Moreover dental anchor 174 may be configured in a shape which corresponds to a shape of channel or groove 172 such that the two may be interfitted in a mating engagement. In this manner, the transducer in assembly 170 may vibrate directly against dental anchor 174 which may then transmit these signals directly into the tooth TH.

[0096] Figs. 18A and 18B show partial cross-sectional side and top views, respectively, of another variation in which oral appliance 180 may define a number of channels or grooves 184 along a top portion of oral appliance 180. Within these channels or

grooves 184, one or more transducers 182, 186, 188, 190 may be disposed such that they are in contact with the occlusal surface of the tooth and each of these transducers may be tuned to transmit frequencies uniformly. Alternatively, each of these transducers may be tuned to transmit only at specified frequency ranges. Accordingly, each transducer can be  
5 programmed or preset for a different frequency response such that each transducer may be optimized for a different frequency response and/or transmission to deliver a relatively high-fidelity sound to the user.

[0097] In yet another variation, Figs. 19A and 19B illustrate an oral appliance 200 which may be pre-formed from a shape memory polymer or alloy or a superelastic material such as a Nickel-Titanium alloy, e.g., Nitinol. Fig. 19A shows oral appliance 200 in a first  
10 configuration where members 202, 204 are in an unbiased memory configuration. When placed upon or against the tooth TH, members 202, 204 may be deflected into a second configuration where members 202', 204' are deformed to engage tooth TH in a secure interference fit, as shown in Fig. 19B. The biased member 204' may be utilized to press the  
15 electronics and/or transducer assembly contained therein against the tooth surface as well as to maintain securement of the oral appliance 200 upon the tooth TH.

[0098] Similarly, as shown in Fig. 20, removable oral appliance 210 may have biased members to secure engage the tooth TH, as above. In this variation, the ends of the members 212, 214 may be configured into curved portions under which a transducer element 218  
20 coupled to electronics assembly 216 may be wedged or otherwise secured to ensure mechanical contact against the tooth surface.

[0100] Fig. 21 shows yet another variation in which the oral appliance is omitted entirely. Here, a composite dental anchor or bracket 226, as described above, may be adhered directly onto the tooth surface. Alternatively, bracket 226 may be comprised of a  
25 biocompatible material, e.g., stainless steel, Nickel-Titanium, Nickel, ceramics, composites, etc., formed into a bracket and anchored onto the tooth surface. The bracket 226 may be configured to have a shape 228 over which an electronics and/or transducer assembly 220 may be slid over or upon via a channel 222 having a corresponding receiving configuration 224 for engagement with bracket 226. In this manner, assembly 220 may be directly engaged  
30 against bracket 226, through which a transducer may directly vibrate into the underlying tooth TH. Additionally, in the event that assembly 220 is removed from the tooth TH, assembly

220 may be simply slid or rotated off bracket 226 and a replacement assembly may be put in its place upon bracket 226.

[0101] Figs. 22A and 22B show partial cross-sectional side and perspective views, respectively, of yet another variation of an oral appliance 230. In this variation, the oral

5 appliance 230 may be configured to omit an occlusal surface portion of the oral appliance 230 and instead engages the side surfaces of the tooth TH, such as the lingual and buccal surfaces only. The electronics and/or transducer assembly 234 may be contained, as above, within a housing 232 for contact against the tooth surface. Additionally, as shown in Fig. 22B, one or more optional cross-members 236 may connect the side portions of the oral appliance 230 to provide some structural stability when placed upon the tooth. This variation may define an occlusal surface opening 238 such that when placed upon the tooth, the user may freely bite down directly upon the natural occlusal surface of the tooth unobstructed by the oral appliance device, thereby providing for enhanced comfort to the user.

[0102] In yet other variations, vibrations may be transmitted directly into the

15 underlying bone or tissue structures rather than transmitting directly through the tooth or teeth of the user. As shown in Fig. 23A, an oral appliance 240 is illustrated positioned upon the user's tooth, in this example upon a molar located along the upper row of teeth. The electronics and/or transducer assembly 242 is shown as being located along the buccal surface of the tooth. Rather than utilizing a transducer in contact with the tooth surface, a conduction transmission member 244, such as a rigid or solid metallic member, may be coupled to the transducer in assembly 242 and extend from oral appliance 240 to a post or screw 246 which is implanted directly into the underlying bone 248, such as the maxillary bone, as shown in the partial cross-sectional view of Fig. 23B. As the distal end of transmission member 244 is coupled directly to post or screw 246, the vibrations generated by the transducer may be transmitted through transmission member 244 and directly into post or screw 246, which in turn transmits the vibrations directly into and through the bone 248 for transmission to the user's inner ear.

[0103] Fig. 24 illustrates a partial cross-sectional view of an oral appliance 250 placed upon the user's tooth TH with the electronics and/or transducer assembly 252 located along the lingual surface of the tooth. Similarly, the vibrations may be transmitted through the conduction transmission member 244 and directly into post or screw 246, which in this

example is implanted into the palatine bone PL. Other variations may utilize this arrangement located along the lower row of teeth for transmission to a post or screw 246 drilled into the mandibular bone.

[0104] In yet another variation, rather utilizing a post or screw drilled into the  
5 underlying bone itself, a transducer may be attached, coupled, or otherwise adhered directly to the gingival tissue surface adjacent to the teeth. As shown in Figs. 25A and 25B, an oral appliance 260 may have an electronics assembly 262 positioned along its side with an electrical wire 264 extending therefrom to a transducer assembly 266 attached to the gingival tissue surface 268 next to the tooth TH. Transducer assembly 266 may be attached to the  
10 tissue surface 268 via an adhesive, structural support arm extending from oral appliance 260, a dental screw or post, or any other structural mechanism. In use, the transducer may vibrate and transmit directly into the underlying gingival tissue, which may conduct the signals to the underlying bone.

[0105] For any of the variations described above, they may be utilized as a single  
15 device or in combination with any other variation herein, as practicable, to achieve the desired hearing level in the user. Moreover, more than one oral appliance device and electronics and/or transducer assemblies may be utilized at any one time. For example, Fig. 26 illustrates one example where multiple transducer assemblies 270, 272, 274, 276 may be placed on multiple teeth. Although shown on the lower row of teeth, multiple assemblies may  
20 alternatively be positioned and located along the upper row of teeth or both rows as well. Moreover, each of the assemblies may be configured to transmit vibrations within a uniform frequency range. Alternatively in other variations, different assemblies may be configured to vibrate within non-overlapping frequency ranges between each assembly. As mentioned above, each transducer 270, 272, 274, 276 can be programmed or preset for a different  
25 frequency response such that each transducer may be optimized for a different frequency response and/or transmission to deliver a relatively high-fidelity sound to the user.

[0106] Moreover, each of the different transducers 270, 272, 274, 276 can also be  
programmed to vibrate in a manner which indicates the directionality of sound received by the microphone worn by the user. For example, different transducers positioned at different  
30 locations within the user's mouth can vibrate in a specified manner by providing sound or vibrational queues to inform the user which direction a sound was detected relative to an



orientation of the user. For instance, a first transducer located, e.g., on a user's left tooth, can be programmed to vibrate for sound detected originating from the user's left side. Similarly, a second transducer located, e.g., on a user's right tooth, can be programmed to vibrate for sound detected originating from the user's right side. Other variations and queues may be utilized as these examples are intended to be illustrative of potential variations.

5 [0107] In variations where the one or more microphones are positioned in intra-buccal locations, the microphone may be integrated directly into the electronics and/or transducer assembly, as described above. However, in additional variation, the microphone unit may be positioned at a distance from the transducer assemblies to minimize feedback. In one  
10 example, similar to a variation shown above, microphone unit **282** may be separated from electronics and/or transducer assembly **280**, as shown in Figs. 27A and 27B. In such a variation, the microphone unit **282** positioned upon or adjacent to the gingival surface **268** may be electrically connected via wire(s) **264**.

[0108] Although the variation illustrates the microphone unit **282** placed adjacent to  
15 the gingival tissue **268**, unit **282** may be positioned upon another tooth or another location within the mouth. For instance, Fig. 28 illustrates another variation **290** which utilizes an arch **19** connecting one or more tooth retaining portions **21**, **23**, as described above. However, in this variation, the microphone unit **294** may be integrated within or upon the arch **19** separated from the transducer assembly **292**. One or more wires **296** routed through arch **19**  
20 may electrically connect the microphone unit **294** to the assembly **292**. Alternatively, rather than utilizing a wire **296**, microphone unit **294** and assembly **292** may be wirelessly coupled to one another, as described above.

[0109] In yet another variation for separating the microphone from the transducer assembly, Fig. 29 illustrates another variation where at least one microphone **302** (or  
25 optionally any number of additional microphones **304**, **306**) may be positioned within the mouth of the user while physically separated from the electronics and/or transducer assembly **300**. In this manner, the one or optionally more microphones **302**, **304**, **306** may be wirelessly coupled to the electronics and/or transducer assembly **300** in a manner which attenuates or eliminates feedback, if present, from the transducer.

30 [0110] The applications of the devices and methods discussed above are not limited to the particular embodiments described but may include any number of further applications.

Moreover, such devices and methods may be applied to other sites within the body.

Modification of the above-described assemblies and methods for carrying out the invention, combinations between different variations as practicable, and variations of aspects of the invention that are obvious to those of skill in the art are intended to be within the scope of the  
5 claims.

## CLAIMS

1. A communication apparatus, comprising:  
a bone conduction communication apparatus, comprising:  
5 a housing having a shape which is conformable to at least a portion of at least one tooth of a user;  
a transceiver mounted in the housing; and  
a transducer disposed within or upon the housing and in vibratory communication with a surface of the at least one tooth to transmit sound  
10 through the at least one tooth; and,  
a communication device coupled to the transceiver to link the user with a second person.
2. The apparatus of claim 1, comprising a hearing protection unit adapted to be inserted  
15 or positioned within or in proximity to the user's ear.
3. The apparatus of claim 1 or claim 2, further comprising a positioning system to transmit positional information to the transceiver to be delivered to the transducer.
- 20 4. The apparatus of any one of the preceding claims, wherein the communication device transmits the user's position to another location.
5. The apparatus of any one of the preceding claims, wherein the communication device is interoperable with at least one additional communication device.  
25
6. The apparatus of any one of the preceding claims, wherein the communication device comprises a wireless communication device.
7. The apparatus of claim 6 wherein the wireless communication device comprises a  
30 radio or wireless telephone.

8. The apparatus of any one of the preceding claims, comprising a user interface to alter a channel, volume, or both.
9. The apparatus of claim 8, wherein the user interface is mounted on a weapon to enable the user to control a channel, volume, or both without removing the user's hand.
10. The apparatus of claim 8, wherein the user interface is voice activated to enable hands-free operation.
11. The apparatus of any one of the preceding claims, comprising a motion sensor to detect a force imposed on the user.
12. The apparatus of claim 11, comprising a protective vest actuated by the motion sensor.
13. The apparatus of claim 11, comprising a protective vest that inflates when the motion sensor detects an incoming force.
14. The apparatus of claim 12 or claim 13, wherein the protective vest is actuated by a blast.
15. The apparatus of any one of claims 12 to 14, comprising a linkage coupling the vest and a helmet, the linkage being hardened when the blast is detected.
16. The apparatus of any one of the preceding claims, comprising a controller that disables the communication apparatus when worn by an unauthorized user.
17. The apparatus of any one of claims 11 to 15, wherein the motion sensor captures a blast vector comprising direction and magnitude of a blast.
18. The apparatus of claim 17, wherein the blast vector is stored and transmitted to another location.

19. The apparatus of any one of claims 11 to 15, 17 and 18, wherein the motion sensor comprises an accelerometer.

5 20. The apparatus of claim 19, wherein the motion sensor comprises a three axis accelerometer.

21. A communication apparatus substantially as described herein with reference to the accompanying drawings.

10

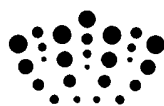

**Application No:** GB0918226.2

**Examiner:** Mr Jared Stokes

**Claims searched:** 1, 2, 5-7

**Date of search:** 26 January 2010

**Patents Act 1977: Search Report under Section 17**

**Documents considered to be relevant:**

Category	Relevant to claims	Identity of document and passage or figure of particular relevance
X,Y	X: 1, 5-10; Y: 2	WO2007/140367 A3 (Sonitus) See paragraphs 70-77
Y	2	US7010139 B1 (Smeehuyzen) See column 4 last paragraph
X,P	1,2,5-8	WO2009/111404 A1 (Sonitus) See whole document
X,P	1, 2, 5-8	US2009/0226020 A1 (Abolfathi et al.) See paragraphs 5, 12-15
X,P	1, 2, 5-10	WO2009/102889 A1
A	-	US2004/0202344 A1 (Anjanappa et al.) See paragraph 34

**Categories:**

X	Document indicating lack of novelty or inventive step	A	Document indicating technological background and/or state of the art.
Y	Document indicating lack of inventive step if combined with one or more other documents of same category.	P	Document published on or after the declared priority date but before the filing date of this invention.
&	Member of the same patent family	E	Patent document published on or after, but with priority date earlier than, the filing date of this application.

**Field of Search:**

Search of GB, EP, WO & US patent documents classified in the following areas of the UKC<sup>X</sup> :

Worldwide search of patent documents classified in the following areas of the IPC

A61F; G02C; H04B; H04M; H04R

The following online and other databases have been used in the preparation of this search report

EPODOC, INSPEC, WPI

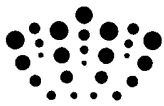

**International Classification:**

<b>Subclass</b>	<b>Subgroup</b>	<b>Valid From</b>
H04M	0001/60	01/01/2006
H04B	0001/38	01/01/2006