



- (51) **International Patent Classification:**
A45F 5/00 (2006.01)
- (21) **International Application Number:**
PCT/US2014/029952
- (22) **International Filing Date:**
15 March 2014 (15.03.2014)
- (25) **Filing Language:** English
- (26) **Publication Language:** English
- (30) **Priority Data:**
61/801,540 15 March 2013 (15.03.2013) US
61/876,234 11 September 2013 (11.09.2013) US
- (63) **Related by continuation (CON) or continuation-in-part (CIP) to earlier applications:**
US 61/801,540 (CON)
Filed on 15 March 2013 (15.03.2013)
US 61/876,234 (CON)
Filed on 11 September 2013 (11.09.2013)
- (71) **Applicant:** HSG, LLC [US/US]; 87 Old Hammocks Road, Swansboro, NC 28584 (US).
- (72) **Inventors:** GADAMS, Matthew; 87 Old Hammocks Road, Swansboro, NC 28584 (US). HIGDON, Albert;
- 725 Highway 172, Hubert, NC 28539 (US). HIGDON, Rebecca; 725 Highway 172, Hubert, NC 28539 (US).
- (74) **Agent:** KING, Mark; Humphries & King, P.C., 2018 Eastwood Road, Suite 204, Wilmington, NC 28403 (US).
- (81) **Designated States** (unless otherwise indicated, for every kind of national protection available): AE, AG, AL, AM, AO, AT, AU, AZ, BA, BB, BG, BH, BN, BR, BW, BY, BZ, CA, CH, CL, CN, CO, CR, CU, CZ, DE, DK, DM, DO, DZ, EC, EE, EG, ES, FI, GB, GD, GE, GH, GM, GT, HN, HR, HU, ID, IL, IN, IR, IS, JP, KE, KG, KN, KP, KR, KZ, LA, LC, LK, LR, LS, LT, LU, LY, MA, MD, ME, MG, MK, MN, MW, MX, MY, MZ, NA, NG, NI, NO, NZ, OM, PA, PE, PG, PH, PL, PT, QA, RO, RS, RU, RW, SA, SC, SD, SE, SG, SK, SL, SM, ST, SV, SY, TH, TJ, TM, TN, TR, TT, TZ, UA, UG, US, UZ, VC, VN, ZA, ZM, ZW.
- (84) **Designated States** (unless otherwise indicated, for every kind of regional protection available): ARIPO (BW, GH, GM, KE, LR, LS, MW, MZ, NA, RW, SD, SL, SZ, TZ, UG, ZM, ZW), Eurasian (AM, AZ, BY, KG, KZ, RU, TJ, TM), European (AL, AT, BE, BG, CH, CY, CZ, DE, DK, EE, ES, FI, FR, GB, GR, HR, HU, IE, IS, IT, LT, LU, LV, MC, MK, MT, NL, NO, PL, PT, RO, RS, SE, SI, SK, SM,

[Continued on next page]

(54) **Title:** THIGH-MOUNTED CARRIER PANEL

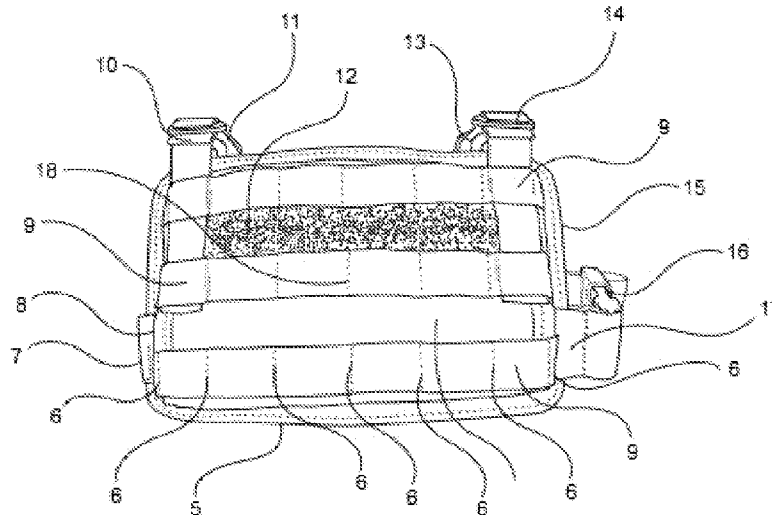
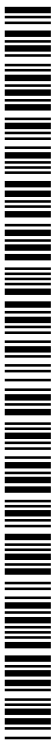

FIG. 1

(57) **Abstract:** Articulated as broadly as possible, the present invention is a device for the carrying of items and implement, the device comprising a firm but pliable panel, means whereby items may be attached to the surface of the panel in such way that the items are not obstructed from the reach of a user; and means whereby the panel may be attached to a user. The means whereby items may be attached to the surface of the panel is contemplated to be a pouch attachment ladder system (PALS) or one or more ammunition magazine retention devices integrated with the disclosed carrying panel.





TR), OAPI (BF, BJ, CF, CG, CI, CM, GA, GN, GQ, GW, KM, ML, MR, NE, SN, TD, TG).

— of inventorship (Rule 4.17(iv))

Declarations under Rule 4.17:

- as to applicant's entitlement to apply for and be granted a patent (Rule 4.17(ii))
- as to the applicant's entitlement to claim the priority of the earlier application (Rule 4.17(iii))

Published:

- without international search report and to be republished upon receipt of that report (Rule 48.2(g))
- with sequence listing part of description (Rule 5.2(a))

IN THE UNITED STATES PATENT AND TRADEMARK OFFICE
Utility Patent Application
Patent Cooperation Treaty International Application

5

TITLE OF THE INVENTION.

10

[0001] Thigh-Mounted Carrier Panel

CROSS-REFERENCE TO RELATED APPLICATIONS.

15

[0002] This application claims the benefit of priority to United States Provisional Application No. 61/801,540 filed March 15, 2013. The content of United States Provisional Application No. 61/801,540 is incorporated by reference herein in its entirety. This application further claims the benefit of priority to United States Provisional Application No. 61/876,234 filed September 11, 2013. The content of United States Provisional Application No. 61/876,234 is incorporated by reference herein in its entirety.

20

STATEMENT REGARDING FEDERALLY SPONSORED RESEARCH OR DEVELOPMENT.

25

[0003] Not Applicable.

THE NAMES OF THE PARTIES TO A JOINT RESEARCH AGREEMENT.

[0004] Not Applicable.

30

INCORPORATION-BY-REFERENCE OF MATERIAL SUBMITTED ON A COMPACT

DISC.

[0005] Not Applicable.

5 TECHNICAL FIELD

[0006] The present invention is in the technical field of devices designed for the holding and carrying of small and personal items in a manner that is convenient and readily accessible to a user. More specifically, the present invention is in the technical
10 field of devices designed to retain and secure small and personal items to the person, clothing, or gear of a user.

[0007] As will be seen in the invention disclosure below, specific embodiments of the now disclosed invention are in the technical field of devices designed for the holding and
15 carrying of ammunition. More particularly, the present invention is in the technical field of devices designed to retain and secure ammunition magazines to the person, clothing, or gear of a user.

20 BACKGROUND ART

[0008] Known in the prior art are examples of storage pouches and bags that may be worn by a user, many specifically with a thigh-mounting or leg rig configuration contemplated. While effective to store and carry small items, the pouches and bags all suffer from common problem – the use of a pouch or bag is not optimal in
25 circumstances where quick and unimpeded access to an item is desirable or needed.

[0009] Illustrative of the body of prior art in this area are World Intellectual Property Organization (WIPO) publication WO2006/119230A1 of Patent Cooperation Treaty (PCT) patent application filed by applicant Murdoch on 28 April 2006 (the “Murdoch
30 Disclosure”), and European Patent Office publication EP2399480A1 of patent application filed by applicant Verrini on 23 June 2010 (the “Verrini Disclosure”). The Murdoch Disclosure provides for a cooperating backpack and waist bag carrying

system, the waist bag component being of particular importance to the now discussed state of the prior art. Specifically, the waist bag component of the invention contemplated by the Murdoch Disclosure provides for an easily accessible bag that may be utilized to store and carry small personal items and which may be conveniently positioned at a plurality of positions in about the circumference of a user's waist to enable a user selected ease of access. Likewise, the Verrini Disclosure provides a bag apparatus that is specifically to be attached to the upper thigh of a user to facilitate greater ease of access by a user. As with the Murdoch Disclosure, the Verrini Disclosure again exclusively contemplates a bag or pouch as the storage means or vessel whereby the user may store and carry small personal items.

[0010] In short, the utilization of a bag or pouch as the functional storage or carrying component known in the prior art is undesirable in many circumstances due to delays in access and detriments to convenience of use occasioned by the user having to negotiate a lid, flap or other means whereby the bag or pouch is closed at the top. There is no doubt that closure of the bag or pouch at the top is a functional necessity to ensure that the contents of the bag or pouch remain securely within the storage compartment, however, closure of the pouch has the unwanted secondary effect of obstructing a user's quick and convenient entry to the storage compartment to access items contained within.

[0011] In the circumstance of a bag or pouch that utilizes a flap mechanism to close the storage compartment, the flap mechanism demands at least three dedicated user motions for the task of negotiating the flap mechanism – typically a first motion to unfasten the flap mechanism, a second motion to clear the obstruction of the flap, and a third motion to restrain the flap from returning to an obstructive position while items within the storage compartment are accessed. In the primary goal of accessing an item contained within the storage compartment, these three additional motions are unnecessary and cumbersome. While not notably concerning in all circumstances, the delays and detriments caused in access to the storage compartment of a bag or pouch as identified above can be extremely prejudicial in certain circumstances, including without limitation combat sequences, low-light scenarios, certain sporting activities, and

circumstances where the use of both hands may be impaired. Particularly in the case of combat circumstances, the delay occasioned by the three additional motions necessary to negotiate the flap mechanism can be the difference between life and death for a user.

5 [0012] The above-cited limitations of the prior art demonstrate that there remains a need in the marketplace for a storage device that not only may be comfortably worn by a user, but also that allows the secure storage of items without the encumbrances imposed by an enclosed storage vessel. The market is ripe for a device that securely stores articles in such way that the articles are naked, but firmly retained, and thus
10 readily accessible by the hand of a user. In this vein, wearable storage devices that utilize powerful magnets to attract and retain metallic articles such as tools are well-known in the prior art, but these magnetic devices leave much to be desired when their respective mass and tendency to only work with metallic articles is considered. Accordingly, there remains a need for a wearable storage device that stores articles in
15 such way that the articles are naked, but firmly retained, and thus readily accessible by the hand of a user, and that does not require the use of heavy magnets only serviceable for retaining metallic articles.

[0013] Exploring the combat circumstance further, the market is also ripe for
20 introduction of a storage device that can securely retain and carry the implements of modern combat, including without limitation ammunition magazines, pistols, knives, etc. While devices for the storage and carrying of these combat related items are well known in the as magazine pouches and leg-rigs, gun holsters, and the like, those items known in the prior art continue to generally comprise pouches, pockets, etc. having a lid or
25 holsters having a securing top strap, each of these designs suffering from the aforementioned shortcoming of requiring unneeded and detrimental additional user motions to free the stored articles from the storage vessel.

[0014] Well known in the prior art are leg drop carrying devices that store multiple
30 articles well, particularly ammunition magazines, pistols, and other combat implements. As known in the prior art, these devices frequently strap about the thigh of a user and comprise a bag or pouch for storage of combat or tactical magazines, weapons or

effects coupled with strapping means the wrap around the rear of the user's leg to secure the device in place on the leg. Further, many of these devices feature a second strapping means whereby the device is suspended from the waistband of the users pants, whether via attachment to the user's belt loops, waistband, or the waist belt itself.

5 This latter feature is what gives the "leg drop" its namesake, as the devices frequently appear to be suspended from the user's waistline. While the stated stated features are no doubt sufficient and perhaps even desirable to securely and efficiently affix a combat or tactical carrying pouch to the thigh of a user, the problem remains that the bag or pouch is an enclosed vessel and, therefore, requires unnecessary user motions in order
10 to gain access to the contents.

[0015] Further known in the art are means of carrying and stowing combat and tactical implements in which the implement is outfitted with a clip-style device that allows the implement to be clipped to a user's waist belt directly or otherwise to clip directly to
15 universal tactical webbing, including MOLLE webbing, on the clothing or gear of a user. A representative example of this body of prior art known is that ammunition magazine carrying device disclosed in European Patent Office publication EP2442064A2 of patent application featuring the inventions of Crye and filed with the European Patent Office on 05 September 2011 (the "Crye Disclosure"). As will be appreciated from the Crye
20 Disclosure, this body of prior art abandons the concept of an enclosed vessel pouch or bag and seeks to modify the tactical implement itself such that it "stores itself" by means of a clip that affixes directly to the implement and that is agnostic with regard to what receiving component may allow its attachment to the body or clothing of a user. While easier to access by the user, the Crye Disclosure device sacrifices secure retention of
25 the combat implement in the name of convenience of access – this sacrifice leaves this body of prior art wanting as well.

[0016] Accordingly, there is a clear need in the prior art for a device that allows the secure carrying and retention of varying items and implements, but which does so in a
30 way that does not impede a user's access to the items and implements. While the inventors would assert that this need is universal, specific applicability is noted for the combat and tactical gear industries.

DISCLOSURE OF INVENTION.

[0017] Articulated as broadly as possible, the present invention is a device for the carrying of items and implements, the device comprising a firm but pliable panel, means
5 whereby items may be attached to the surface of the panel in such way that the items are not obstructed from the reach of a user; and means whereby the panel may be attached to a user.

[0018] In a preferred embodiment of the above-disclosed broad invention, it is
10 contemplated that the means whereby items may be attached to the surface of the panel in such way that the items are not obstructed from the reach of a user may be one or more strips of elastic material affixed to a surface of the panel, the points of affixation of the strip to the panel being at spaced intervals along the length of the strip. More specifically, it is contemplated that the strips of elastic material would be formed of an
15 elastic synthetic fabric such as nylon, and the affixation of the strips of fabric at spaced intervals along the length of the strip would effect a webbing of loops of elastic fabric between affixation points across a face of the panel. The webbing of loops of two or more elastic fabric strips effected by the affixation of the strips to the surface of the panel at spaced intervals across the face of the panel is referred to herein as a
20 "attachment ladder system" (ALS). With still more specificity, the preferred embodiments anticipate that the fabric strips would be affixed to the panel at evenly-spaced intervals, thus effecting a webbing of uniform loops between affixation points across the face of the panel.

[0019] Looking at the specifications contemplated for the elastic fabric webbing
25 attachment means more in depth, one or more of the synthetic fabric webbing strips may be aligned in a horizontal orientation across the face of the panel thereby effecting one or more rows of webbing loops wherein an item, clip or fastener may be vertically inserted and thereby attached to the overall device. In a preferred embodiment, the now
30 disclosed invention contemplates that the fabric webbing strips may be affixed to the front surface of the panel at evenly spaced intervals and that the horizontally-oriented fabric webbing strips may be each evenly spaced from one another. More specifically, in

the case of the preferred embodiment, it is expressly contemplated that each fabric webbing strip would be affixed to the panel at evenly-spaced intervals of 1.5" each along its length thus effecting a webbing of uniform 1.5" loops between affixation points across the face of the panel, and each fabric webbing strip would be spaced 1" from any other
5 horizontal fabric webbing strip, creating a well-spaced matrix of 1.5" webbing loops vertically spaced 1" from one another across the face of the panel.

[0020] As for the panel itself, user comfort is a primary concern and, therefore, design of an ergonomically pleasing panel is paramount. It is contemplated that the
10 panel could comprise a firm but pliable core material, a first surface formed of a fabric suitable to be in constant contact with the leg of a user, and a second surface formed of a durable and pliable fabric having the aforementioned attachment means, including without limitation the aforementioned elastic synthetic fabric webbing, integrated, and the first surface and second surface enveloping the panel core. In practice, the panel
15 core should double as a structural component of the panel and a cushioning agent enhancing the comfort level of the overall device to a user. It is contemplated that the panel core may preferentially be formed of any material of the class comprising nylon, kydex injection-molded plastic, or thermoplastic acrylic-polyvinyl chloride.

[0021] Elaborating on the varying embodiments of the broadest articulated invention further, it is contemplated that the device may further comprise the hook or loop component of a hook and loop fastening system integrated on the face of the panel, in addition to or in lieu of the previously identified elastic synthetic fabric webbing. In what is considered a preferred embodiment of the now disclosed device, it is contemplated
20 that an outward facing surface of the panel may be divided into two sections, preferably an upper-half and a lower-half, the first section comprising the hook or loop component of a hook and loop fastening system, and the second section comprising the durable fabric otherwise comprising the front surface of the panel. The selected component of the hook and loop fastening system to comprise the outward facing surface of the panel
25 is contemplated to complement its respective "partner" component featured on the exterior of particular items and implements to be stowed and carried using the panel. While not the primary means of attachment of items or implements to the panel, the
30

hook and loop fastening system provides additional support for the attachment of items via insertion in the fabric webbing strips. For example, if the outward facing surface of the panel features the loop component of a hook and loop fastening system, a flashlight to be stowed and carried using the now disclosed device might feature the hook component of the hook and loop fastening system thereby allowing the flashlight to be secured to the panel via insertion through an elastic fabric webbing loop on the face of the panel and by completion of the hook and loop fastening system by engagement of the loop component of the panel with the hook component on the exterior of the flashlight.

[0022] In terms of the means whereby the device may be attached to the person of a user, the preferred embodiments contemplate that attachment is accomplished via a two-fold system wherein both a first dedicated means of vertically stabilizing the device and a second dedicated means of horizontally stabilizing the device are utilized. More specifically, the preferred embodiments anticipate that the first dedicated means facilitating vertical stabilization may be one or more adjustable strapping and buckle assemblies, the strapping being attached to the panel at one or more points along the top edge of the panel and defining a loop of strapping that may be affixed to the user's clothing, waist belt, gear or accessories at a point above the thigh of the user. It is contemplated that the second dedicated means facilitating horizontal stabilization may be at least one adjustable strapping and buckle assembly, the strapping being attached to the panel at a first edge and an opposite second edge in such way that the assembly forms an enclosed void between the strapping and the first surface of the panel in which the leg of a user may be enveloped. Further, the now disclosed invention anticipates that either or both of the first dedicated means and the second dedicated means facilitating attachment and stabilization may be removable and interchangeable with components of similar construction if not similar size.

[0023] As before noted, the now disclosed invention is anticipated to have particularized applicability in the context of stowing and carrying combat and tactical items and implements. In recognition of this applicability, an alternative preferred embodiment of that invention set forth in the broadest articulation above contemplates

that the means whereby items may be attached to the surface of the panel in such way that the items are not obstructed from the reach of a user may be specifically designed for common uses in combat and tactical circumstances. Specifically, it is contemplated that an open pocket or compartment for the secure stowing of items, including without
5 limitation ammunition magazines, may be integrated with the outward face of the panel, whether by dedicated and permanent affixation to the panel or by attachment to the aforementioned fabric webbing featured across the outward face of the panel. Due to the industry need for such stowing or carrier devices that provide unobstructed user access to the combat or tactical implements stowed or carried, it is important that the
10 open pocket or compartment for the secure stowing of items, as now disclosed, not feature any components that interferes with the direct access of a user's hand to the item stowed or carried. Examples of undesirable features in this context include pocket flaps or other "closing means", and/or holster-style securing straps or other obstructing "retention means".

15 [0024] Accordingly, the now disclosed alternative preferred embodiment of the broadest disclosed invention integrates with the carrying panel means for the secure stowing and retention of an ammunition magazine, pistol, knife, or the like, the means comprising a pocket defined by a first pair of opposing side panels and a second pair of
20 opposing side panels, the first pair of opposing side panels being in substantially perpendicular plane to the second pair of opposing side panels, a bottom panel, and a top opening; and biasing means whereby at least one pair of opposing side panels are biased toward one another. In the case of a carrying panel in which the now stated means for the secure stowing and retention of combat or tactical implements is fully
25 integrated with the surface of the panel, the panel and the secure stowing and retention means may be joined by any traditionally understood method of joining two such components, including without limitation, by riveting, by sewn seam, by snap-lock fastener assembly, by adhesive means, or the like. In the case of a carrying panel in which the now stated means for the secure stowing and retention of combat or tactical
30 implements is not fully integrated with the surface of the panel and, in fact, is detachable and interchangeable, the means for stowing and retention must further comprise attachment means whereby the pocket may be attached to the panel. Specifically, in this

latter context, it is contemplated the attachment means will be a clip or hook that allows attachment of the means for the secure stowing and retention to the carrying panel via engagement with the previously disclosed elastic fabric webbing featured across the outward face of the carrying panel.

5

[0025] The above-stated alternative embodiment of the now-disclosed invention tailored for application in the combat and tactical gear industries may be restated with varying amounts of specificity directed at varying features of the means for secure stowing and retention without straying from the inventive essence of the contemplated alternative embodiment. For example, the means for secure stowing and retention may feature left and right opposing side panels, and front and back opposing side panels, the four recited side panels defining a pocket when coupled with a bottom panel. Either the left and right opposing side panels or the front and back opposing side panels may be designed to be the shorter in height to allow retention of an ammunition magazine while mitigating the risk of "catching" an exposed ammunition round on the edge of a side panel when removing the magazine from the pocket. Likewise, variations are contemplated in which (i) the left and right opposing side panels, or (ii) the front and back opposing side panels, or (iii) both pairs of opposing side panels may feature biasing means whereby the respective pairs of opposing side panels are biased toward one another.

20

[0026] Similarly, for the purposes of this particular alternative embodiment, it is appreciated that the biasing means featured as a component of the means for secure stowing and retention could take a number of forms. For instance, the biasing means could be as simplistic as a shock cord or bungee wrapped around the exterior of a pair of opposing panels, thus pulling the panels toward one another. The biasing means could just as easily be a shock cord or bungee wrapped around the exterior of both pairs of opposing panels, and, in fact, this latter contemplated embodiment of the biasing means is representative of the inventors' believed best mode of the now discussed alternative embodiment. Still further, the biasing means could be the simple spring-action of a singular and rigid molded component comprising a pair of opposing

30

side panels and the bottom panel of the now disclosed invention. By molding this component in such a way that the opposing side panels are not parallel to one another, but rather converging, resistance is created when any object is placed between the opposing side panels wedging them apart. In fact, this disclosed singular and rigid
5 molded component comprising a pair of opposing side panels and the bottom panel of the now disclosed invention is also representative of the inventors' believed best mode of the now disclosed invention.

[0027] Still further, it is appreciated that the degree of height differential as between
10 the two pairs of opposing side panels of the means for secure stowing and retention now contemplated is an aspect of the invention that may be variable. The inventive essence is believed to be captured in the fact that the height differential exists, and not in the specific degree of that differential. That said, certain degrees of height differential will be recognized as beneficial, specifically those degrees of differential that allow
15 avoidance of the clamping of an inwardly biased side panel upon an exposed round of ammunition at the dispensing end of a magazine as the magazine is removed from the inventive retention device and transitioned to a weapon.

[0028] In practice, the means for secure stowing and retention defines a pocket,
20 pouch or well for the retention and storing of an ammunition magazine or the like. One of ordinary skill in the art will appreciate that a pocket, pouch, or well may further comprise a divider that segments the pocket, pouch, or well into two or more separate compartments, each compartment being capable of the storage of an ammunition magazine under the principles of the invention herein disclosed. In fact, one preferred
25 embodiment of the means for secure stowing and retention accomplishes that very feat, a segmented pocket, pouch or well for the retention and storage of an ammunition magazine or the like.

[0029] In function, the now disclosed means for secure stowing and retention
30 improves upon the known prior art in that the biasing means whereby at least one pair of opposing side panels are biased inwardly toward one another is deemed beneficial in

that the biasing of the side panels results in a pocket that applies constant frictional force to the sides of an inserted magazine or item, but which allows the same magazine or item to be freely removed without further obstruction by a user. In the case of a stowed ammunition magazine utilized in conjunction with the means for secure stowing and retention featuring a height differential in its pocket side panels, the magazine may be freely rotated out of the pocket once withdrawn far enough that a round of ammunition may clear the shorter pair of opposing side panels and the magazine may be laterally rotated out of the pocket while the taller pair of opposing side panels continue to apply frictional force against the rigid sides of the ammunition magazine. Hence, a round of ammunition exposed at the base of an ammunition magazine is released from the pocket without being caught or hung on an inwardly biased side of the pocket, a substantial problem in the known prior art. Further, the continued use of inward biasing of at least one pocket panel continues to allow constant pressure of frictional force against the rigid exterior of the magazine, thus allowing the secure retention and stowing of the magazine despite jarring or other forces acting on the magazine to cause it to eject or be inadvertently released from the top opening of the pocket.

INDUSTRIAL APPLICABILITY.

20

[0030] It is a primary objective of the herein disclosed invention to provide for the secure storage and retention of items and implements by way of a device that is both convenient and comfortable for a user to wear.

25

[0031] It is a primary objective of the herein disclosed invention to provide for a convenient and comfortable wearable device for the stowing and carrying of items that sacrifices neither speed of access nor security of retention in its design.

30

[0032] It is a further objective of the herein disclosed invention to provide for a wearable device for the stowing and retention of a variety of items and implements that specifically leaves the items and implements store exposed for easy access by a user.

[0033] It is a further objective of the herein disclosed invention to provide for a wearable device for the stowing and retention of a variety of items and implements that comprises such a simplistic and universally compatible configuration as to be useful in the storage of a very diverse array of items or implements.

[0034] It is a specific objective of the herein disclosed invention to provide for the secure stowing and retention of combat and tactical implements, including without limitation ammunition magazines, pistols and pistol clips, flashlights, and scopes, flash suppressors and other firearm accessories, and to provide for such stowing and retention in a way that allows the quickest possible access to these sometimes life-saving articles.

[0035] It is a general objective of the herein disclosed invention to provide for an improved leg drop rig for carrying and stowing items, particularly in a combat or tactical circumstance, not relying on enclosed vessels for storage and retention, but rather providing all desirable elements of the leg drop rig while ensuring unobstructed access to items and implements store and retained therein.

[0036] It is a further primary objective of the now disclosed invention to provide a device capable of securely stowing a variety of items that a user may carry and require to be conveniently accessible, including, without limitation, a rifle magazine, a pistol or handgun, a flashlight, a cellular telephone, a medication dispenser or storage bottle, a notepad, a keyring, a remote control, a stun gun or taser device, a folding knife, a pepper spray canister, or the like.

[0037] It is a further objective of the now disclosed invention to provide a device capable of securely stowing a variety of items that itself is extraordinarily durable for use under heavy use and/or extreme conditions.

[0038] These and other advantages and features of the present embodiment are described with specificity below so as to make the present disclosure understandable to

one of ordinary skill in the art.

BRIEF DESCRIPTION OF DRAWINGS.

5 [0039] FIG. 1 is a front view of the best mode of a first disclosed embodiment of the present invention;

[0040] FIG. 2 is a rear view of the best mode of the first disclosed embodiment of the disclosed present invention;

10

[0041] FIG. 3 is a front view of the best mode of a second disclosed embodiment of the disclosed present invention;

15 [0042] FIG. 4 is a rear view of the best mode of the second disclosed embodiment of the disclosed present invention;

[0043] FIG. 5A is a perspective view of the best mode of the second disclosed embodiment of the disclosed present invention, as the embodiment might look while in use by a person viewed from the side; and

20

[0044] FIG. 5B is a perspective view of the best mode of the second disclosed embodiment of the disclosed present invention, as the embodiment might look while in use by a person viewed from the front.

25 MODE(S) FOR CARRYING OUT THE INVENTION.

[0045] Referring now to the best mode of a first embodiment of the invention in more detail, in FIG. 1 there is shown a front view of the best mode of the disclosed present invention, the displayed best mode illustrating a panel 5 comprising a core formed of any material of the class comprising nylon, kydex, injection-molded plastic, or
30 thermoplastic acrylic-polyvinyl chloride; a rear surface panel formed of any durable fabric; and a front surface 18 split into an upper-half 15 and a lower-half 7, the upper-

half 15 formed of either the loop assembly 12 or the hook assembly (not shown) of a hook and loop fastener system and the lower-half 7 formed of any durable fabric; three horizontal rows of nylon 9 spaced at least 1" from each other, each row of nylon 9 being affixed to the front surface 18 of the panel 5 at seven 1.5 inch intervals 6; a horizontal stabilizing strap-on assembly 16 connected to the panel 5 at a first point 8 on the left edge of the panel 5 and a second point 17 on the right edge of the panel 5; a vertical stabilizing strap-on assembly comprising a left strap 10 and a right strap 14, evenly spaced and the bottom portion of the left strap 10 and the right strap 14 respectively attached to the upper-half 15 of the front surface 18 of the panel 5 by hook and loop fastener system, the left strap 10 folding back upon itself at its top portion 11 and the top terminus being attachable to point in the middle of the left strap 10 by fastening means thus creating a loop in the top portion 11 of the left strap 10, and the right strap 14 folding back upon itself at its top portion 13 and the top terminus being attachable to a point in the middle of the right strap 14 by fastening means thus creating a loop in the top portion 13 of the right strap 14.

[0046] Referring now to the best mode of the first disclosed embodiment of the invention in more detail, in FIG. 2 there is shown a rear view of the best mode of the disclosed present invention, the displayed best mode again illustrating the panel 5 comprising a core formed of any material of the class comprising nylon, kydex, injection-molded plastic, or thermoplastic acrylic-polyvinyl chloride; a rear surface panel formed of any durable fabric; and a front surface split into an upper-half and a lower-half, the upper-half formed of either the loop assembly or the hook assembly (not shown) of a hook and loop fastener system and the lower-half formed of any durable fabric; a rear surface 19 formed of any durable fabric; and a layer of padding or cushioning 20 between the core and the rear surface 19; three horizontal rows of nylon spaced at least 1" from each other, each row of nylon being affixed to the front surface of the panel 5 at seven 1.5 inch intervals; a horizontal stabilizing strap-on assembly 16 connected to the panel 5 at a first point 8 on the left edge of the panel 5 and a second point 17 on the right edge of the panel 5; a vertical stabilizing strap-on assembly comprising a left strap 10 and a right strap 14, evenly spaced and the bottom portion of the left strap 10 and the right strap 14 respectively attached to the upper-half of the front surface of the panel

5 by hook and loop fastener system, the left strap 10 folding back upon itself at its top portion 11 and the top terminus being attachable to point in the middle of the left strap 10 by fastening means thus creating a loop in the top portion 11 of the left strap 10, and the right strap 14 folding back upon itself at its top portion 13 and the top terminus being
5 attachable to a point in the middle of the right strap 14 by fastening means thus creating a loop in the top portion 13 of the right strap 14.

[0047] Referring now to FIG. 1 and FIG. 2, the intended use of the now disclosed invention is that the horizontal stabilizing strap-on assembly 16 connected to the panel 5
10 be utilized to strap the panel 5 to the upper thigh of a user and the vertical stabilizing strap-on assembly comprising a left strap 10 and a right strap 14 be used to connect the panel 5 to the user's belt to better secure the panel 5 during use. Once the panel 5 is snugly installed on the user's upper thigh, small items and personal items maybe stored on the panel 5, including without limitation knives, magazine clips, magazine clip
15 holders, first aid kits and any item having a protrusion capable of engaging the attachment ladder system (ALS) created by the three horizontal rows of nylon 9 spaced at least 1" from each other, each row of nylon 9 being affixed to the front surface 18 of the panel 5 at seven 1.5 inch intervals 6. In this sense, the panel 5 may be readily and securely worn on the upper thigh, thus placing all items held within the PALS created by
20 the three horizontal rows of nylon 9 spaced at least 1" from each other, each row of nylon 9 being affixed to the front surface 18 of the panel 5 at seven 1.5 inch intervals 6 within the ready reach of the user. In addition to the PALS created by the three horizontal rows of nylon 9, the upper-half 15 of the front surface 18 of the panel 5 is further equipped with either the loop assembly 12 or the hook assembly (not shown) of
25 a hook and loop fastener system, thus allowing the further securing of items to the panel 5 by way of the enhanced retention strength provided when an item is both inserted into the PALS created by the three horizontal rows of nylon 9 and engaged by the loop assembly 12 when the item features the complimentary hook assembly to complete the hook and loop fastener system.

30

[0048] Referring now to the best mode of a second embodiment of the invention in more detail, in FIG. 3 there is shown a front view of the best mode of the disclosed

present invention, the best mode being an apparatus for the attachment of a magazine dispenser to the person of a user, the apparatus comprising (i) a panel 29 having a front 24 and a cushioned back; (ii) a first device 23 for the secure stowing of a magazine affixed to the front 24 of the panel 29; (iii) a second device 22 for the secure stowing of a magazine affixed to the front 24 of the panel 29; (iv) a third device 21 for the secure stowing of a magazine affixed to the front 24 of the panel 29; (v) a horizontal stabilizing strap 40 wrapped about the front 24 of the panel 29 and able to be adjusted for a tight fit about the upper leg of a user via manipulation of an anterior slide buckle 44, a posterior slide buckle 41, and engagement of the male component 42 and female component 43 of a side release buckle; (vi) a left vertical stabilizing strap 35 and a right vertical stabilizing strap 37 able to be adjusted for vertical positioning of the panel 29 along the upper leg of a user via manipulation of a left slide buckle 34 on the left vertical stabilizing strap 35, a right slide buckle 36 on the right vertical stabilizing strap 37, engagement of a left male slide release buckle component 27 connected to the left vertical stabilizing strap 35 with a left female slide release buckle component 26 connected to a left panel 29 support strap 25, and engagement of a right male slide release buckle component 38 connected to the right vertical stabilizing strap 37 with a right female slide release buckle component 28 connected to a right panel 29 support strap 39.

20

[0049] Referring now to the best mode of the second disclosed embodiment of the invention in more detail, in FIG. 4 there is shown a rear view of the best mode of the disclosed present invention, the best mode being an apparatus for the attachment of a magazine dispenser to the person of a user, the apparatus comprising (i) a panel 29 having a front and a cushioned back 30; (ii) a first device 23 for the secure stowing of a magazine affixed to the front of the panel 29; (iii) a second device 22 for the secure stowing of a magazine affixed to the front of the panel 29; (iv) a third device 21 for the secure stowing of a magazine affixed to the front of the panel 29; (v) a horizontal stabilizing strap 40 wrapped about the front of the panel 29 and able to be adjusted for a tight fit about the upper leg of a user via manipulation of an anterior slide buckle 44, a posterior slide buckle 41, and engagement of the male component 42 and female

25

30

component 43 of a side release buckle; (vi) a left vertical stabilizing strap 35 and a right vertical stabilizing strap 37 able to be adjusted for vertical positioning of the panel 29 along the upper leg of a user via manipulation of a left slide buckle 34 on the left vertical stabilizing strap 35, a right slide buckle 36 on the right vertical stabilizing strap 37, engagement of a left male slide release buckle component 27 connected to the left vertical stabilizing strap 35 with a left female slide release buckle component 26 connected to a left panel 29 support strap 25, and engagement of a right male slide release buckle component 38 connected to the right vertical stabilizing strap 37 with a right female slide release buckle component 28 connected to a right panel 29 support strap 39.

[0050] In more detail and still referring to the best mode of FIG. 3 and FIG. 4, the invention as depicted functions by attachment of the panel 29 to the upper thigh of a user by wrapping the horizontal stabilizing strap 40 around the upper thigh and adjusting the length of the horizontal stabilizing strap 40 as needed to provide a snug, formfitting compression between the upper thigh of the user and the cushioned back 30 of the panel 29. The horizontal stabilizing strap 40 is adjusted via manipulation of the posterior slide buckle 41 and the anterior slide buckle 44 and is secured via insertion of the horizontal stabilizing strap 40 male side release buckle component 42 into the horizontal stabilizing strap 40 female side release buckle component 43 until the horizontal stabilizing strap 40 male side release buckle component 42 clicks firmly in place. The vertical positioning of the panel 29 on the upper thigh of a user is determined and adjusted by wrapping the left vertical stabilizing strap 35 and the right vertical stabilizing strap 37 through the waist belt of a user and adjusting the vertical height of the panel 29 via manipulation of the left slide buckle 34 on the left vertical stabilizing strap 35, manipulation of the right slide buckle 36 on the right vertical stabilizing strap 37, insertion of the left male slide release buckle component 27 connected to the left vertical stabilizing strap 35 into the left female slide release buckle component 26 connected to the left panel 29 support strap 25 until the left male slide release buckle component 27 clicks firmly in place, and insertion of the right male slide release buckle component 38 connected to the right vertical stabilizing strap 37 into the right female slide release

buckle component 28 connected to the right panel 29 support strap 39 until the right male slide release buckle component 38 clicks firmly in place. Once the positioning of the panel 29 is adjusted such that there is a snug formfitting compression between the cushioned back 30 of the panel 29 and the upper thigh of the user, the apparatus is ready for use and magazine clips as appropriate may be inserted into first device 23, second device 22, and third device 21 as needed to ensure the convenient and secure stowing and transport of ammunition magazines by a user.

[0051] Referring now to the best mode of the second disclosed embodiment of the invention in more detail, in FIG. 5A there is shown a perspective view of the best mode of the disclosed present invention as the embodiment might look while in use by a person 32 viewed from the side. Likewise, in FIG. 5B there is shown a perspective view of the best mode of the disclosed present invention as the embodiment might look while in use by a person 32 viewed from the front. In more detail and still referring to the best mode of FIG. 5A and FIG. 5B, the invention as depicted demonstrates the attachment of the invention to the upper thigh 33 of a person 32 via wrapping of the horizontal stabilizing strap 40 around the upper thigh 33 of the person 32 and securing of the same by engagement of the female slide release buckle component 43 connected to the horizontal stabilizing strap 40 with its male counterpart (*not shown*) also connected to the horizontal stabilizing strap 40. Further, the views of FIG. 5A and FIG. 5B clearly demonstrate the relationship between the waist belt 31 of a person 32 and the left vertical stabilizing strap 35 and right vertical stabilizing strap 37, both of which are wrapped through the waist belt 31 while worn by a person, and then locked in place, the left vertical stabilizing strap 35 by engagement of the female slide release buckle component 26 connected to the left vertical stabilizing strap 35 with its male counterpart (*not shown*) also connected to the left vertical stabilizing strap 35, and the right vertical stabilizing strap 37 by engagement of the female slide release buckle component 28 connected to the right vertical stabilizing strap 37 with its male counterpart (*not shown*) also connected to the right vertical stabilizing strap 37. As shown and as contemplated to be worn by a person 32, the first device 23, second device 22, and third device 21, along with the front 24 of the apparatus all face outward from the upper thigh 33 of the

person 32.

[0052] The construction details of the best mode as shown in FIG. 3, FIG. 4, FIG. 5A and FIG. 5B are as follows: the panel 29 is contemplated to be constructed in layers with the composite panel 29 being pliable and formfitting to the upper thigh 33 of a person 32. More specifically, the panel 29 comprises the front 24 of the panel 29 constructed from a dense and durable fabric, the central panel contemplated to be constructed of any pliable and durable material, and the cushioned back 30 of the panel 29, contemplated to be constructed soft and pliable material including, but not limited to a solid foam or sponge material. The horizontal stabilizing strap 40, left vertical stabilizing strap 35, right vertical stabilizing strap 37, left panel 29 support strap 25, and right panel 29 support strap 39 are to be constructed of a durable and flexible material including, but not limited to a heavy duty fabric such as canvas or, preferably, a material having a substantial degree of elasticity. The posterior slide buckle 41, anterior slide buckle 44, male slide release buckle components 42 38 27, and female slide release buckle components 43 28 26 are each contemplated to be constructed from a rigid and durable plastic such as polyvinyl chloride (PVC).

[0053] Reference throughout the specification to features, advantages, or similar language does not imply that all of the features and advantages that may be realized with the present invention should be or are in any single embodiment of the invention. Rather, language referring to the features and advantages is understood to mean that a specific feature, advantage, or characteristic described in connection with an embodiment is included in at least one embodiment of the present invention. Thus, discussion of the features and advantages, and similar language, throughout the specification may, but do not necessarily, refer to the same embodiment.

[0054] Furthermore, the described features, advantages, and characteristics of the invention may be combined in any suitable manner in one or more embodiments. One skilled in the relevant art will recognize that the invention can be practiced without one or more of the specific features or advantages of a particular embodiment. In other

instances, additional features and advantages may be recognized in certain embodiments that may not be present in all embodiments of the invention.

[0055] It is understood that the above described embodiments are only illustrative of the application of the principles of the present invention. The present invention may be embodied in other specific forms without departing from its spirit or essential characteristics. The described embodiment, including the best mode, is to be considered in all respects only as illustrative and not restrictive. The scope of the invention is, therefore, indicated by the appended claims, if any, in conjunction with the foregoing description.

[0056] The foregoing description of the preferred embodiment of the present invention has been presented for the purpose of illustration and description. It is not intended to be exhaustive or to limit the invention to the precise form disclosed. Many modifications and variations are possible in light of the above teachings. It is intended that the scope of the present invention not be limited by this detailed description, but by the claims and the equivalents to the claims appended hereto.

[0057] While the foregoing written description of the invention enables one of ordinary skill to make and use what is considered presently to be the best mode thereof, those of ordinary skill will understand and appreciate the existence of variations, combinations, and equivalents of the specific embodiment, method, and examples herein. The invention should therefore not be limited by the above described embodiment, method, and examples, but by all embodiments and methods within the scope and spirit of the invention.

CLAIM OR CLAIMS.

[0058] I claim:

5 [0059] 1. A conveniently accessible and wearable device for the carrying of items, the device comprising —

a panel having a front surface upon which items may be attached or stored and a cushioned back surface;

10 dedicated means whereby the panel may be attached to the thigh of a user such that the cushioned back surface is in contact with the thigh of the user and the attachment of the panel to the thigh of the user is horizontally stabilized; and

dedicated means means whereby the panel may be attached to the thigh of a user such that the cushioned back surface is in contact with the thigh of the user and the attachment of the panel to the thigh of the user may be vertically stabilized.

15

[0060] 2. The device of Claim 1 wherein the panel front surface further comprises one or more strips of flexible material affixed to the front surface at two or more points along the length of each strip.

20 [0061] 3. The device of Claim 2 wherein the strips of flexible material are strips of an elastic nylon-based fabric.

[0062] 4. The device of Claim 3 wherein at least one strip of elastic nylon-based fabric is affixed to the front surface at regular intervals along the length of each strip.

25

[0063] 5. The device of Claim 3 wherein at least one strip of elastic nylon-based fabric is affixed to the front surface horizontally across the front surface.

30 [0064] 6. The device of Claim 2 wherein the panel front surface further comprises either the hook assembly or the loop assembly of a hook and loop fastening system.

[0065] 7. The device of Claim 1 wherein the panel front surface further comprises at least one storage apparatus comprising a pocket defined by four side panels and a bottom panel and means whereby at least one pair of opposing side
5 panels are biased toward one another.

[0066] 8. The device of Claim 7 wherein the storage apparatus is permanently affixed to the panel front surface by affixation means joining one side panel of the storage apparatus to the panel front surface.
10

[0067] 9. The device of Claim 8 wherein the storage apparatus further comprises a dividing panel whereby the apparatus pocket is divided into two or more compartments.

[0068] 10. The device of Claim 7 wherein the storage apparatus is removably attached to the panel front surface via hook and loop fastening means or via direct attachment of the storage apparatus via a pouch attachment ladder system integrated with the panel front surface.
15

[0069] 11. The device of Claim 10 wherein the storage apparatus further comprises a dividing panel whereby the apparatus pocket is divided into two or more compartments.
20

[0070] 12. The device of Claim 7 wherein the storage apparatus further comprises a dividing panel whereby the apparatus pocket is divided into two or more compartments.
25

[0071] 13. The device of Claim 1 wherein the dedicated means whereby the panel may be attached to the thigh of a user such that the cushioned back surface is in contact with the thigh of the user and the attachment of the panel to the thigh of the user
30 is horizontally stabilized is at least one adjustable strapping and buckle assembly, the

strapping being attached to the panel at two or more points along the edge of the panel and defining an enclosed void between the strapping and the cushioned back surface of the panel in which the leg of a user may be enwrapped.

5 [0072] 14. The device of Claim 13 wherein the dedicated means means whereby the panel may be attached to the thigh of a user such that the cushioned back surface is in contact with the thigh of the user and the attachment of the panel to the thigh of the user may be vertically stabilized is at least one adjustable strapping and buckle assembly, the strapping being attached to the panel at one or more points along the
10 edge of the panel and defining a loop of strapping that may be attached to the user's clothing, gear or accessories at a point above the thigh of the user.

[0073] 15. The device of Claim 1 wherein the dedicated means means whereby the panel may be attached to the thigh of a user such that the cushioned back surface is
15 in contact with the thigh of the user and the attachment of the panel to the thigh of the user may be vertically stabilized is at least one adjustable strapping and buckle assembly, the strapping being attached to the panel at one or more points along the edge of the panel and defining a loop of strapping that may be attached to the user's clothing, gear or accessories at a point above the thigh of the user.

20

[0074] 16. A conveniently accessible and wearable device for the carrying of items, the device comprising —

a panel having a front surface upon which items may be attached or stored;
an attachment ladder system integrated with the front surface; either the hook or the
25 loop component of a hook and loop fastening system integrated with the front surface;
and a cushioned back surface;

two or more strapping and buckle assemblies facilitating the attachment of the panel to the thigh means whereby the panel may be attached to the thigh of a user such that the cushioned back surface is in contact with the thigh of the user;

30 at least one of the adjustable strapping and buckle assemblies having the strapping attached to the panel at two or more points along the edge of the panel and

defining an enclosed void between the strapping and the cushioned back surface of the panel in which the leg of a user may be enwrapped; and

at least one of the adjustable strapping and buckle assemblies having the strapping attached to the panel at one or more points along the edge of the panel and
5 defining a loop of strapping that may be attached to the user's clothing, gear or accessories at a point above the thigh of the user.

[0075] 17. A conveniently accessible and wearable device for the carrying of items, the device comprising —

10 a panel having a front surface upon which items may be attached or stored; at least one storage apparatus integrated with the front surface and further comprising a pocket defined by four side panels and a bottom panel and means whereby at least one pair of opposing side panels are biased toward one another; and a cushioned back surface;

15 two or more strapping and buckle assemblies facilitating the attachment of the panel to the thigh means whereby the panel may be attached to the thigh of a user such that the cushioned back surface is in contact with the thigh of the user;

at least one of the adjustable strapping and buckle assemblies having the strapping attached to the panel at two or more points along the edge of the panel and
20 defining an enclosed void between the strapping and the cushioned back surface of the panel in which the leg of a user may be enwrapped; and

at least one of the adjustable strapping and buckle assemblies having the strapping attached to the panel at one or more points along the edge of the panel and
25 defining a loop of strapping that may be attached to the user's clothing, gear or accessories at a point above the thigh of the user.

[0076] 18. A conveniently accessible and wearable device for the carrying of items, the device comprising —

a panel having a front surface upon which items may be attached or stored;
30 at least one storage apparatus integrated with the front surface and further comprising a pocket defined by four side panels, a dividing panel segmenting the pocket into two or

more compartments, and a bottom panel and means whereby at least one pair of opposing side panels are biased toward one another; and a cushioned back surface;

two or more strapping and buckle assemblies facilitating the attachment of the panel to the thigh means whereby the panel may be attached to the thigh of a user
5 such that the cushioned back surface is in contact with the thigh of the user;

at least one of the adjustable strapping and buckle assemblies having the strapping attached to the panel at two or more points along the edge of the panel and defining an enclosed void between the strapping and the cushioned back surface of the panel in which the leg of a user may be enwrapped; and

10 at least one of the adjustable strapping and buckle assemblies having the strapping attached to the panel at one or more points along the edge of the panel and defining a loop of strapping that may be attached to the user's clothing, gear or accessories at a point above the thigh of the user.

15 [0077] 19. The device of Claim 1 wherein the panel front surface further comprises an attachment ladder system.

[0078] 20. The device of Claim 19 wherein the panel front surface further comprises either the hook assembly or the loop assembly of a hook and loop fastening system.

1 / 5

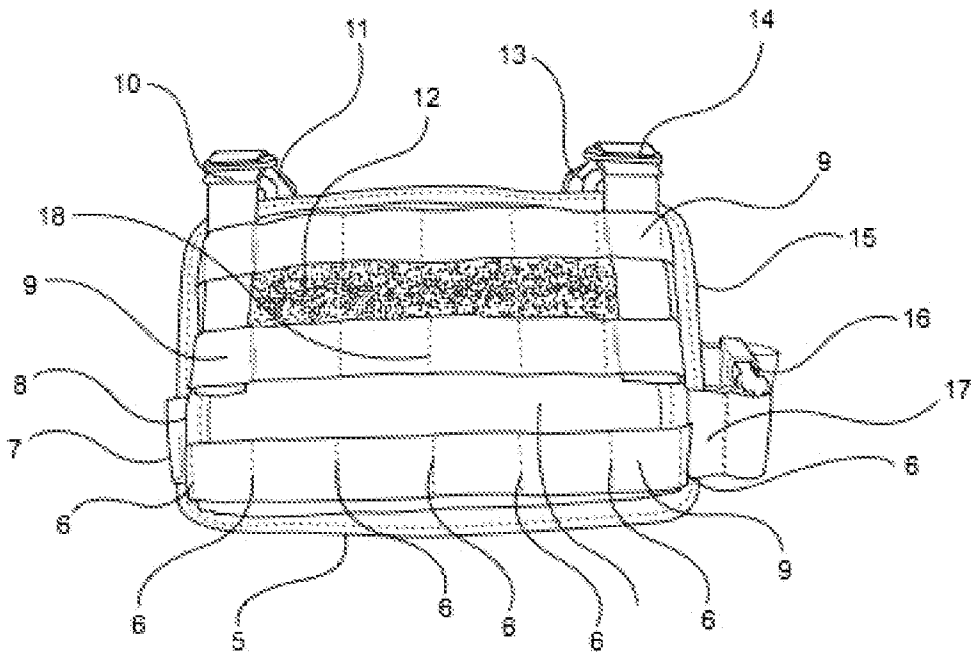

FIG. 1

2 / 5

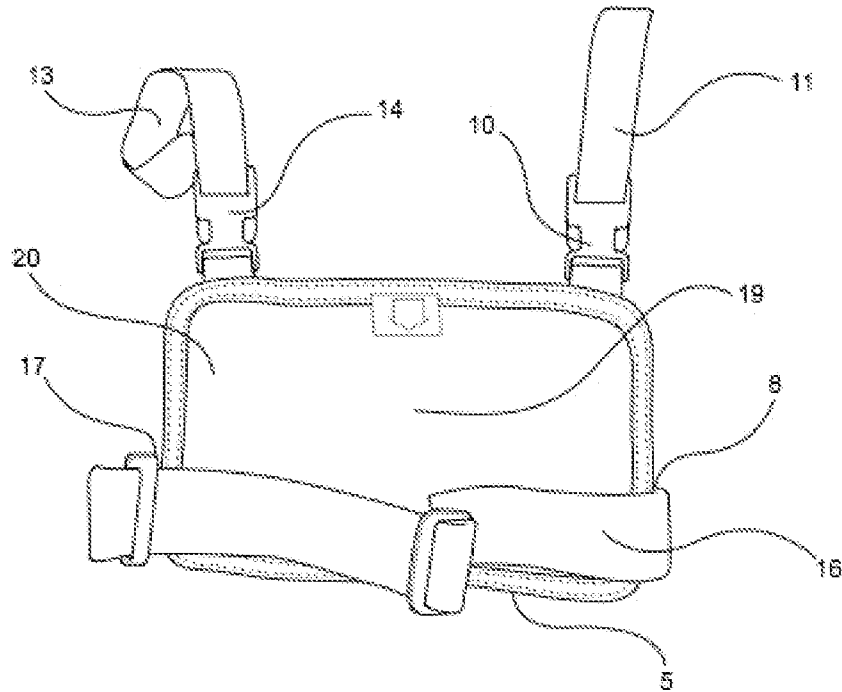

FIG. 2

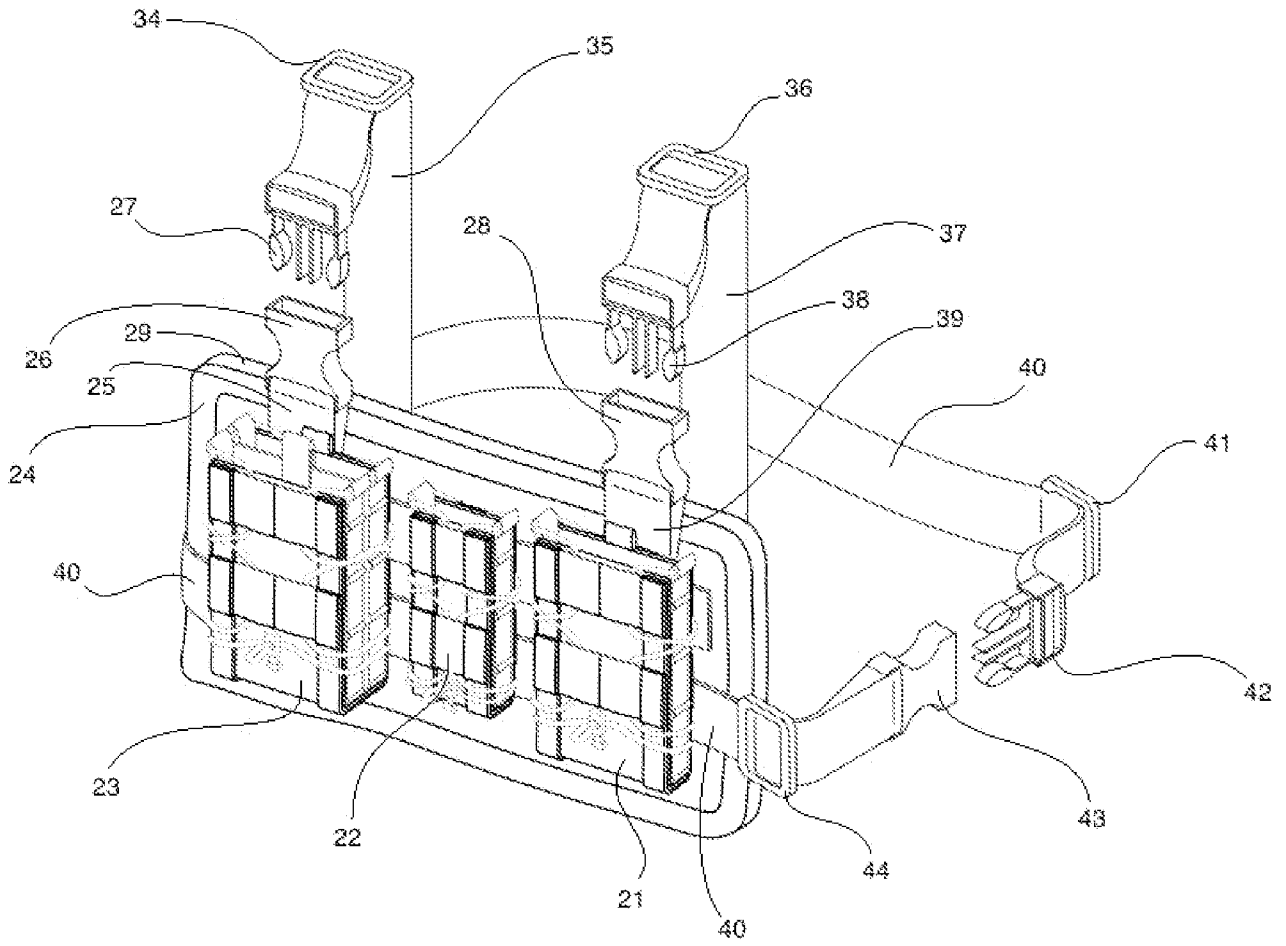

FIG. 3

4 / 5

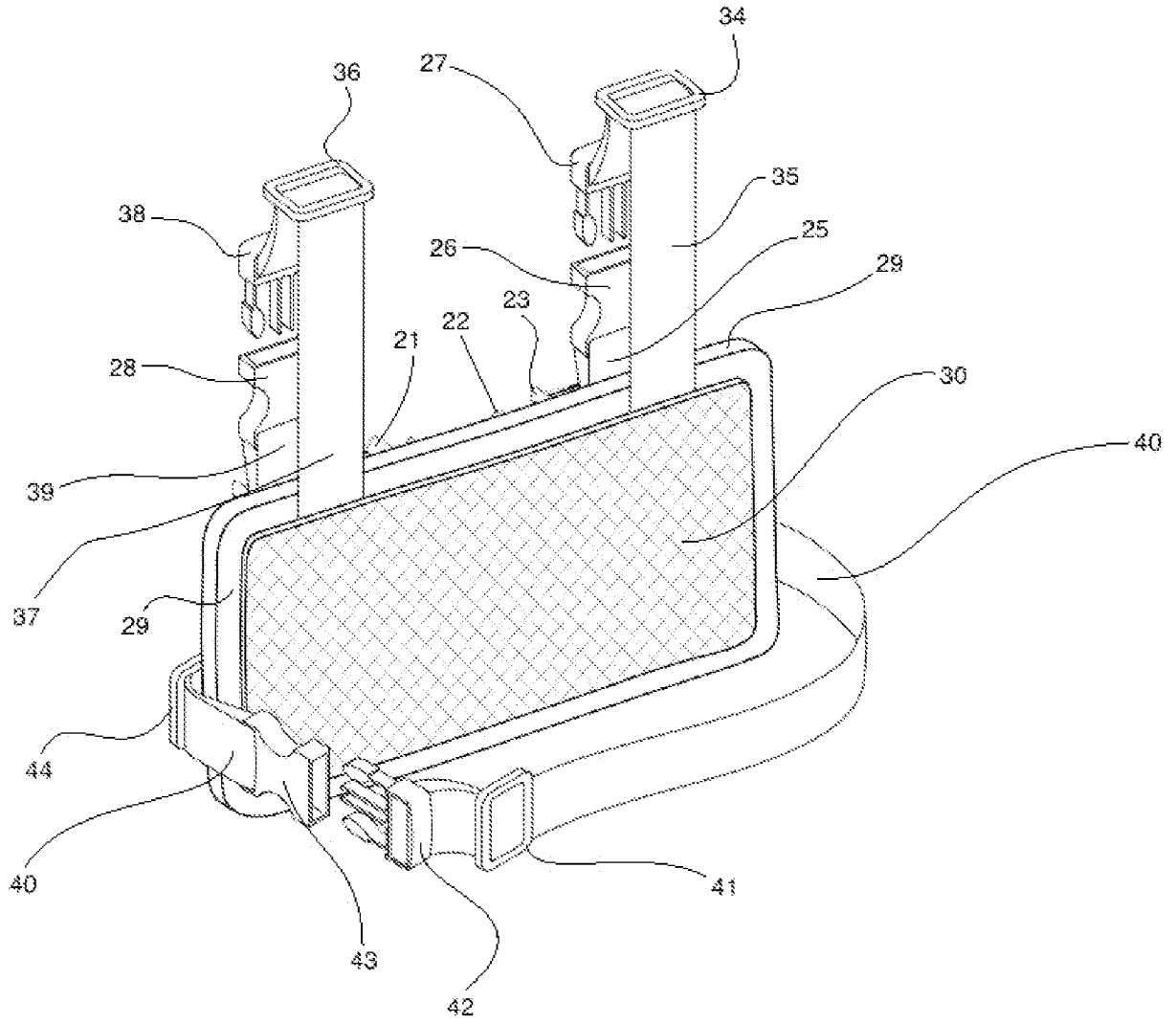

FIG. 4

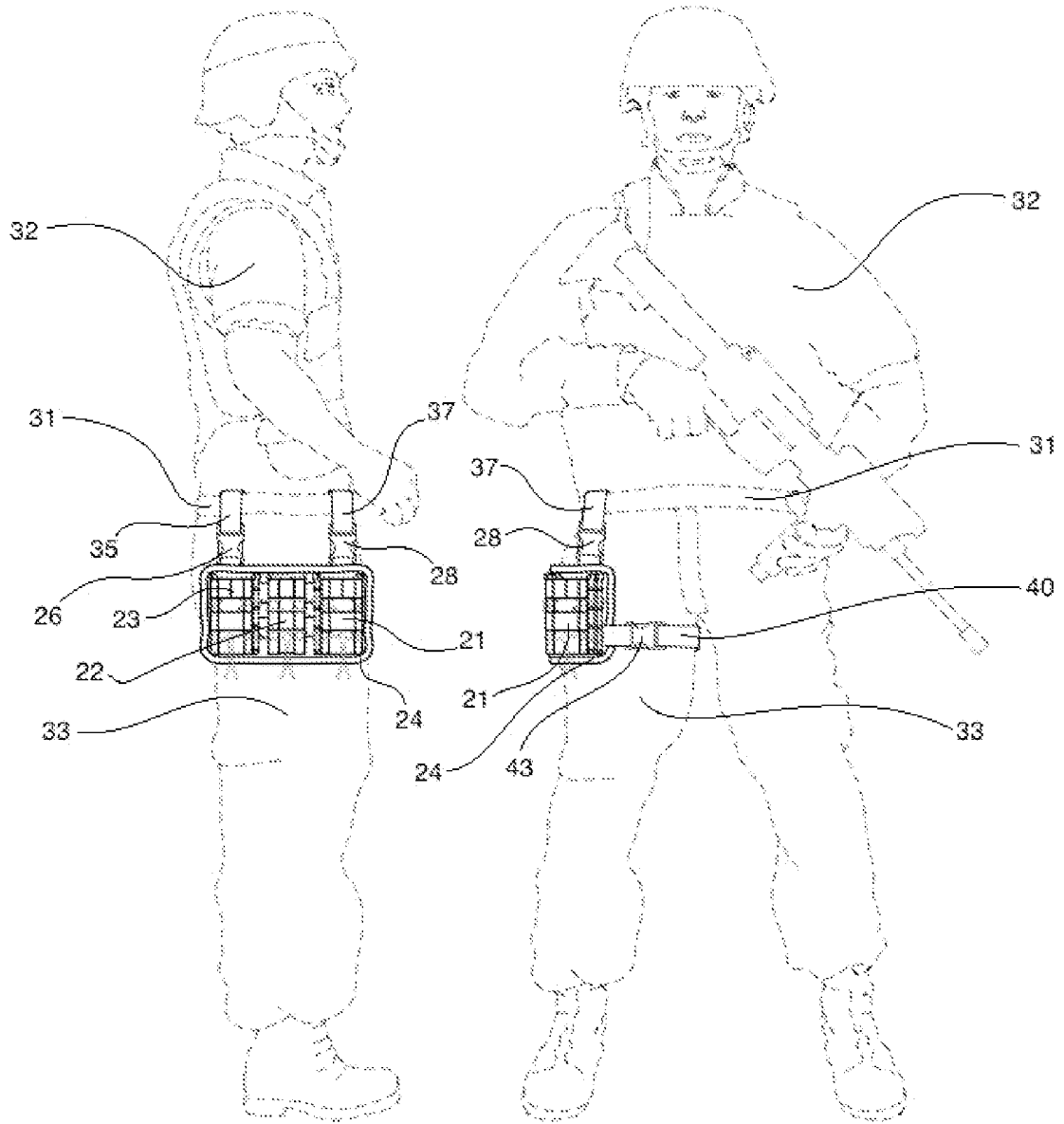

FIG. 5A

FIG. 5B