

(19) World Intellectual Property Organization
International Bureau



(43) International Publication Date
16 February 2006 (16.02.2006)

PCT

(10) International Publication Number
WO 2006/016366 A2

- (51) International Patent Classification:
A61B 3/12 (2006.01) A61B 3/00 (2006.01)
A61B 3/14 (2006.01)
- (21) International Application Number:
PCT/IL2005/000869
- (22) International Filing Date: 11 August 2005 (11.08.2005)
- (25) Filing Language: English
- (26) Publication Language: English
- (30) Priority Data:
60/600,810 12 August 2004 (12.08.2004) US
- (71) Applicants (for all designated States except US): **ELOP ELECTRO-OPTICAL INDUSTRIES LTD.** [IL/IL]; Kiryat Weizman, P.O. Box 1165, 76111 Rehovot (IL). **MEDIVISION MEDICAL IMAGING LTD.** [IL/IL]; P.O.Box 45, Industrial Park, 20698 Yokneam Elit (IL).
- (72) Inventors; and
- (75) Inventors/Applicants (for US only): **ALLON, Noam** [IL/IL]; 39 Shofman Street, 34987 Haifa (IL). **GROSSINGER, Israel** [IL/IL]; 19 Yaacov Street, 76262 Rehovot (IL). **GOLUB, Michael** [IL/IL]; 12 Parshani

Street, 76114 Rehovot (IL). **BRIL, Moshe** [NL/IL]; 511 Haarazim Street, 99552 Beit Shemesh (IL).

- (74) Agent: **REINHOLD COHN AND PARTNERS**; P.O.B. 4060, 61040 Tel-Aviv (IL).
- (81) Designated States (unless otherwise indicated, for every kind of national protection available): AE, AG, AL, AM, AT, AU, AZ, BA, BB, BG, BR, BW, BY, BZ, CA, CH, CN, CO, CR, CU, CZ, DE, DK, DM, DZ, EC, EE, EG, ES, FI, GB, GD, GE, GH, GM, HR, HU, ID, IL, IN, IS, JP, KE, KG, KM, KP, KR, KZ, LC, LK, LR, LS, LT, LU, LV, MA, MD, MG, MK, MN, MW, MX, MZ, NA, NG, NI, NO, NZ, OM, PG, PH, PL, PT, RO, RU, SC, SD, SE, SG, SK, SL, SM, SY, TJ, TM, TN, TR, TT, TZ, UA, UG, US, UZ, VC, VN, YU, ZA, ZM, ZW.
- (84) Designated States (unless otherwise indicated, for every kind of regional protection available): ARIPO (BW, GH, GM, KE, LS, MW, MZ, NA, SD, SL, SZ, TZ, UG, ZM, ZW), Eurasian (AM, AZ, BY, KG, KZ, MD, RU, TJ, TM), European (AT, BE, BG, CH, CY, CZ, DE, DK, EE, ES, FI, FR, GB, GR, HU, IE, IS, IT, LT, LU, LV, MC, NL, PL, PT, RO, SE, SI, SK, TR), OAPI (BF, BJ, CF, CG, CI, CM, GA, GN, GQ, GW, ML, MR, NE, SN, TD, TG).

Declaration under Rule 4.17:
— of inventorship (Rule 4.17(iv)) for US only

[Continued on next page]

(54) Title: INTEGRATED RETINAL IMAGER AND METHOD

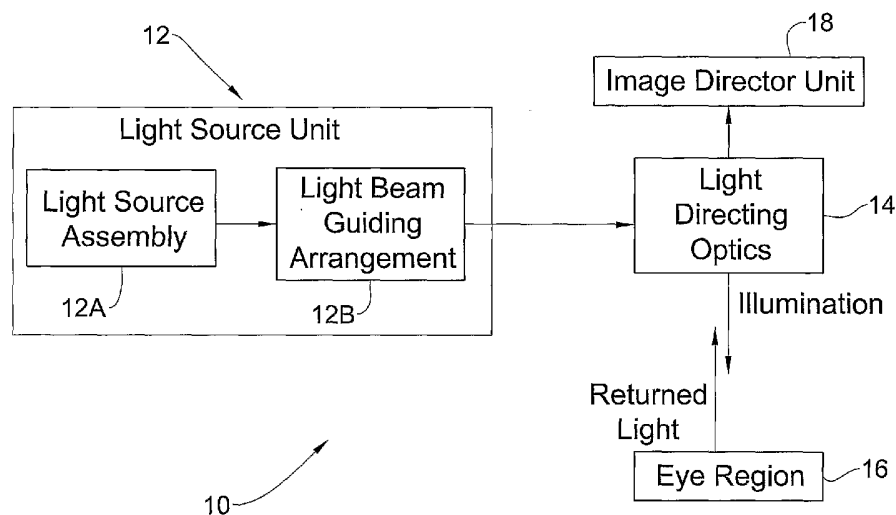

(57) Abstract: A system and method are presented for use in imaging the patient's retina. A light source unit is provided including a light emitting diode (LED) arrangement comprising multiple LEDs of different wavelength ranges. A light guide arrangement is used with the LEDs arrangement and is configured for coupling light from the LEDs and providing output light beams of a desired shape. The illuminating light is directed towards a region on the retina, and light returned from the illuminated region is collected and directed to an image detector unit. The invention enables the use of LED light at high intensity as required in the eye retina imaging, while maintaining the required high-quality imaging. Also, the invention provides for simultaneous or quasi-simultaneous as well as high-speed imaging in FA and ICG imaging procedures, thereby satisfying a long felt need in ophthalmology. Also, the invention provides for automated illumination or light exposure control to optimize overall light exposure to the patient eye and best acquired image quality in terms of brightness, contrast and image signal-to-noise ratio.

WO 2006/016366 A2



Published:

— without international search report and to be republished upon receipt of that report

For two-letter codes and other abbreviations, refer to the "Guidance Notes on Codes and Abbreviations" appearing at the beginning of each regular issue of the PCT Gazette.

INTEGRATED RETINAL IMAGER AND METHOD

FIELD OF THE INVENTION

This invention is generally in the field of optical monitoring techniques, and relates to an imaging system and method, particularly useful in ophthalmology for retinal imaging.

5 BACKGROUND OF THE INVENTION

An imager used to take pictures of the retina is known as a *fundus camera*. These cameras could be used in fundus (retinal) photography and fluorescence angiography procedure. The latter is a retinal examination procedure where fluorescein dye is injected into a patient vein and a fundus camera is used to
10 record images of the retina to reveal retinal blood circulation disorders, such as leakages, hemorrhages, edema and other pathologies.

Roughly speaking, there are two kinds of fundus cameras: mydriatic fundus cameras utilizing continuous illumination of the retina with visible light to permit focusing and non-mydriatic fundus cameras utilizing illumination of
15 the retina with invisible light, such as infrared light, which advantageously is not seen by the patient and therefore does not cause the contraction of the iris during the alignment procedure. Non-mydriatic cameras can be used in cases where dilation of the eye is not possible or in cases, such as screening of the retina, since in those cases following the positioning using invisible light a single high-
20 intensity image of higher illumination (usually white) intensity is used per each patient eye. With the mydriatic fundus camera approach, it is necessary to apply a pupil-dilating (mydriatic) medication to the cornea in order to avoid contraction of the pupil in response to visible light to enable full visualization of the entire retina throughout the clinical procedure. In the non-mydriatic fundus camera,

- 2 -

which allows focus on the retina in the naturally dilated state of the pupil, the eye is illuminated by infrared light and a continuous image is formed on an infrared imaging device or the light sensing plane of an infrared sensor such as a CCD or CMOS video camera.

5 The presently available high-performance fundus cameras typically use Halogen illumination or Xenon-Flash light to obtain various white light, single wavelength light (Red, Green, and Blue - using filters), fluorescein (FA) and Indo-Cyanine Green (ICG or ICGA) fluorescence images.

Clinically, there is a need to follow the fluorescence process throughout
10 the life-cycle of the fluorescence agent, and especially during the initial phase of the agent entering the retinal and choroidal blood circulation. Due to the limitation of current technology in fundus cameras, only 1 or 2 Xenon-flash based images per second are possible to obtain, because of limitations of the energy sources to the Flash devices. Only laser beam based scanning devices
15 (known also as SLO – Scanning Laser Ophthalmoscopes) are able to record such events, with the limitation of smear and motion of the eye during image acquisition, causing limitation in image quality of the retina image.

Various techniques have been developed aimed at improving the performance of a fundus camera. For example, U.S. Patent 5,742,374 discloses a
20 fundus camera for photographing fundus of an eye to be examined. According to this technique, an observing illumination/target projection optical system utilizes a slit-plate having a pin-hole aperture and a ring-slit. The eye to be examined is illuminated with a ring-slit illumination to facilitate alignment and focusing.

The use of LED based illumination in a fundus camera has been proposed,
25 and is described in U.S. Patent 6,685,317. Here, a digital camera is described that combines the functions of the retinal camera and corneal camera into one, single, small, easy-to-use instrument. The single camera can acquire digital images of a retinal region of an eye, and digital images of a corneal region of the eye. The camera includes a first combination of optical elements for making said retinal
30 digital images, and a second combination of optical elements for making said

- 3 -

corneal digital images. In a preferred embodiment, a portion of these elements are shared elements including a first objective element of an objective lens combination, a digital image sensor and at least one eyepiece for viewing either the retina or the cornea. Also, preferably, the retinal combination also includes a
5 first changeable element of said objective lens system for focusing, in combination with said first objective element, portions or all of said retinal region at or approximately at a common image plane. Also, preferably, the retinal combination also includes a retinal illuminating light source, an aperture within said frame and positioned within said first combination to form an effective
10 retinal aperture located at or approximately at the lens of the eye defining an effective retinal aperture position, an infrared camera for determining eye position, and an aperture adjustment mechanism for adjusting the effective retinal aperture based on position signals from said infrared camera. Also, preferably, the cornea combination of elements includes a second changeable element of said
15 objective lens system for focusing, in combination with said first objective element, portions or all of said cornea region at or approximately at a common image plane.

According to the technique of US 6,685,317, light from a large area is collected by a fiber optic bundle. High power LEDs emit over a wide angle
20 typically ± 90 degrees. However, it appears that the optical setup described in this patent suffers *inter alia* from losing the majority of light due to the very small acceptance angle of commercially available fibers.

SUMMARY OF THE INVENTION

There is a need in the art to facilitate imaging of the retina by providing a
25 novel imaging system and method, capable of providing an efficient coupling and directing of light to the region of interest (retina) of the eye, thereby enabling to reach high intensity illumination required to improve the image brightness and diagnostics by means of higher contrast level of the image. Also, an imaging system is to be fully controllable and yet compact in size.

The main idea of the present invention consists of enabling the use of LED light at high intensity as required in the eye retina imaging, while maintaining the required high-quality imaging. To this end, the present invention provides means for effectively coupling the maximal LED energy all along the illumination and imaging channels. Also, the present invention is aimed at providing simultaneous or quasi-simultaneous FA and ICGA imaging, thereby satisfying a long-felt need in ophthalmology.

The present invention provides a novel illumination/imaging system and method for use in an Integrated Retina Imager (fundus camera) that utilizes a LED-based light source. The technique of the present invention enables the LED-based illumination of a region of interest with desirably high intensity comparable with the known Xenon-flash based illumination. The present invention also provides for a novel LED flash capability technique.

According to one broad aspect of the invention, there is provided a system for use in imaging the patient's retina, the system comprising: (a) a light source unit comprising a light emitting diode (LED) arrangement comprising multiple LEDs of different wavelength ranges; (b) a light guide arrangement configured for coupling light from the LEDs and providing output light beams of a desired shape; (c) a light directing optics for directing the light beam towards a region on the retina and for collecting and directing light returned from the illuminated region to an image detector unit.

Preferably, the light source unit is configured for producing at least one ring-like shaped light beam.

The LED arrangement may include at least one LED emitting light in a near infrared spectral range, and/or at least one LED emitting light in a visible spectral range, for example for emitting light of Red, Green, Blue and White colors. The light source unit may also include at least one laser diode.

The system may include a wavelength-selective arrangement formed by one or more wavelength-selective filters (dichroic mirror or mirrors). The latter is appropriately accommodated for combining light from different LED assemblies.

The light directing optics includes an objective lens arrangement, and an imaging lens arrangement, and optionally also a condenser lens arrangement in the optical path of light emitted by the LED arrangement. In some embodiments of the invention, the light directing optics also includes a field lens arrangement
5 in the optical path of the illuminating light, and/or a relay lens arrangement in the optical path of the illuminating light.

In some embodiments of the invention, the LED arrangement includes at least one LED unit formed by a LED and its associated light guide unit configured as a cone-like reflector. The light guide unit is preferably configured
10 to produce the illuminating light beam cone with an angle of about 20-degrees or less.

In some embodiments of the invention, the light source unit is configured to couple light from each of the multiple LEDs into its dedicated fiber or fiber bundle. This may allow for enhancing the illuminating light.

15 In some embodiments of the invention, a ring-like member is used for carrying ends of the multiple fibers arranged along this ring-like member. The opposite ends of the fibers are coupled to the LEDs, respectively. By this, the ring-like light output from the ring-like member is defined. The central hole of the ring-like member may define an imaging channel. The system configuration
20 may be such that at least one of the LEDs is coupled to its associated fiber via a lens arrangement. The fibers may be configured for guiding the light of different wavelengths from the different LEDs. The different wavelengths' fibers may be arranged within the ring-like member so as to reach substantially equal spectral distribution for as small as possible sub-section of the ring-like member. The
25 LEDs may be arranged in a matrix, and may be coupled to their dedicated fibers, respectively, via a lenslet array, such that each lens element of the lenslet array is dedicated to couple one LED to one fiber or fiber bundle.

The LED arrangement may include at least two LED assemblies, each formed by the multiple LEDs coupled via the fibers, respectively, to the ring-like
30 member. The multiple ring-like members may be arranged (e.g., mounted on a

rotatable wheel) so as to enable selectively bring one of the ring-like members to the illuminating optical path.

The light directing optics may include a beam combiner in the form of a mirror with hole. Such a mirror reflects the illuminating light by its periphery reflective region, and transmits the returned light through the central hole. The hole diameter is defined by the eye pupil size and by the magnification of an objective lens arrangement.

The system of the invention provides for using an aperture, formed by the ring-like shaped light beam, as an imaging channel for the returned light propagation.

In some embodiments of the invention, a mask assembly is used being located in the optical path of the illuminating light propagating to the beam combining mirror. The mask assembly is configured to define at least two masks of different patterns, each pattern defining a ring-like shaped light transmitting path.

In some embodiments, the light source unit includes diffractive or refractive optics accommodated in the optical path of light emitted by at least one LED. Such refractive or diffractive optics provides high efficient coupling of Lambertian light into a ring, thereby producing the ring-like shaped light beam.

The light source unit preferably includes an adaptor unit carrying the LED arrangement and configured and operable for selectively shifting one or more of the LEDs into an operation mode. The adaptor unit may be configured as follows: includes at least one first light unit formed by the first light guide unit carrying at its one end the first LED operating in a near infrared range and its other end carrying a first condenser lens arrangement; and at least two second light units each formed by the second light guide unit carrying at its one end the second LED operating in a visible spectral range and carrying a second condenser lens arrangement. The second light unit is arranged along an axis intersecting with the first light unit thereby enabling to combine the first and second light paths. The second light units are mounted on a member rotating with

- 7 -

respect to the first light unit. Preferably, the adaptor unit includes a wavelength-selective arrangement accommodated at the intersection between the first and second optical paths. The adaptor unit preferably includes the multiple second light units containing the LEDs emitting different wavelengths of the visible
5 range.

In some embodiments of the invention, the light source unit includes at least one LED assembly formed by multiple LEDs associated with a common light guide. The latter is configured for coupling light from the multiple LEDs into the single ring-like light beam.

10 The system may include one or more ring-like shaped members, each carrying the multiple LEDs of at least one LED assembly. This creates a ring-like shaped light source formed by the LEDs arranged in a circular array. The LEDs in the circular array may differ in emitting spectra and/or power; or may contain different groups of LEDs, the LEDs of each group being substantially identical in
15 spectrum and/or power, different from that of the other group.

A condenser lens arrangement may be used with at least some of the LEDs to narrow an emitting angle of light. A light diffusing element may be used with at least some of the LEDs to provide substantially uniform illumination of the light beam. A micro lens array may be used to condense or diffuse light
20 emitted by the LEDs in the circular array.

In some embodiments of the invention, the light source unit includes an integrating sphere (at least one such sphere) that carries the multiple LEDs. The sphere is formed with a ring-like window for the light output, and is configured to recycle light emitted by the LEDs by internal reflection in the integrating
25 sphere. The inner surface of the window may be formed with a reflective coating. An external mask may be used being positioned so as to cover an inner diameter of the window. A light guide may be used being accommodated at the window and configured for narrowing light exit angles of the ring-shaped window to match those acceptable by an objective lens arrangement. The integrating sphere
30 may contain light from multiple different wavelength channels; or alternatively

- 8 -

(or additionally) a wavelength-selective arrangement may be used for combining light of different wavelengths from different LED assemblies.

The system may include LEDs emitting light of fluorescence exciting and visible wavelength ranges. In this case, a spectral filter is appropriately accommodated in the optical path of the returned light. The spectral filter may be
5 configured for transmitting excited light, and blocking the exciting light. Such a spectral filter is displaceable between its operating position being in the optical path of returned light and its inoperative position being outside of said optical path. Alternatively, the spectral filter may be configured as a dual spectrum
10 barrier filter defining two spectral bandwidths corresponding to those used for, respectively, fluorescein (FA) and Indo-Cyanine Green (ICG) angiography, thereby enabling to obtain a combined FA/ICG photo by applying visible illumination and NIR flashes simultaneously. In this case, the image detector unit includes a CMOS or CCD detector sensitive to a 400-850nm spectral range.

15 In some embodiments of the invention, the light source unit includes one or more LEDs operating in a pulse (flash) mode. The pulse mode light source unit is operable with 30 or more frames (images) per second. Additionally, the light source unit may include one or more LEDs operating in a continuous illumination mode. In such embodiments, a control unit (connectable to the light
20 source unit and to the image detector unit) is used being configured for analyzing images acquired with the pulse and continuous modes to set appropriate light exposure in either one of the application modes. The control unit is preferably configured to analyze data indicative of the images acquired with the continuous light mode to utilize this data for predicting amount of light exposure to be used
25 in the pulsed mode imaging.

According to another broad aspect of the invention, there is provided a light source unit for use in an imaging system for imaging the patient's retina, the light source unit comprising one or more assemblies each including multiple light emitting diodes (LEDs) arranged for producing a ring-like shaped light beam,
30 each LED being coupled to one end of its dedicated optical fiber or fiber bundle,

the other ends of the fibers or fiber bundles being attached to and arranged along a ring-like member, allowing to use a central hole of the ring-like member as an imaging channel for passing therethrough light returned from an illuminated region.

5 According to yet another broad aspect of the invention, there is provided a light source unit for use in an imaging system for imaging the patient's retina, the light source unit comprising at least two LED based assemblies emitting light of different wavelength ranges; a wavelength-selective assembly comprising at least one wavelength-selective filter accommodated in optical paths of illuminating
10 light beams produced by said at least two LED based assemblies for combining said light beams into a single illuminating light path; a mask configured to define a variable pattern in said combined optical path to affect the light beam impinging thereon to produce therefrom a ring-like shaped light beam.

 According to yet another broad aspect of the invention, there is provided a
15 light source unit for use in an imaging system for imaging of a patient's retina, the light source unit comprising a support assembly configured for supporting at least one first LED based unit emitting light of a first wavelength range; at least two second LED based units for emitting light of at least two different second wavelength ranges; the LED based unit comprising one or more LED associated
20 with a dedicated light guide configured to produce from light emitted by the LED a ring-like shaped light beam; the second light guide extending along an axis intersecting with an axis defined by the first light guide, the second light guides being mounted on a member rotatable with respect to the first light guide, thereby enabling to selectively locate a selected one of the second light guides in
25 an operative position to combine optical paths of light emerging from the first light guide and light emerging from the selected second light guide .

 According to yet another broad aspect of the invention, there is provided an imaging system for use in imaging the patient's retina, the system comprising:
(a) a first camera operable with pulse mode illumination; (b) a second camera
30 operable with continuous mode illumination; and (c) a control system

- 10 -

connectable to the first and second cameras and configured for controlling the operation thereof by analyzing either pulse mode or continuous images or both of them and utilizing reference data indicative of the images corresponding to certain exposure parameters and determining optimal exposure parameters for
5 either the pulse or continuous illumination or both of them.

According to yet another broad aspect of the present invention, there is provided a method for use in imaging the patient's retina, the method comprising producing light of multiple different wavelengths emitted by a light emitting diode (LED) arrangement; passing the emitted light through a light guide
10 arrangement configured for coupling light from the LEDs and providing one or output light beams of a desired shape; directing said output light towards a region on the retina and collecting light returned from the illuminated region through the same objective lens arrangement; and imaging the collected returned light onto an image detector unit.

15 According to yet another broad aspect of the present invention, there is provided a method for controlling the operation of a fundus camera, the method comprising: providing predetermined exposure settings for pulse (flash) light illumination and continuous light illumination; providing data indicative of images acquired by a still image camera and a continuous mode camera;
20 analyzing said data based on said predetermined exposure settings, and determining a new exposure settings to the pulse (flash) light control and the continuous light control, thereby enabling to utilize the continuous light measured data to predict amount of light exposure to be used in the pulse (flash) light illumination.

25 **BRIEF DESCRIPTION OF THE DRAWINGS**

In order to understand the invention and to see how it may be carried out in practice, preferred embodiment will now be described, by way of non-limiting examples only, with reference to the accompanying drawings, in which:

Fig. 1A is a block diagram of functional elements of a system (fundus camera) of the present invention;

Fig. 1B is a schematic illustration of an example of the optical layout of an illumination channel of the system of Fig. 1A;

5 **Fig. 2** exemplifies the configuration of a light source unit of the present invention configured to couple light from many LEDs through optical fibers which form a ring of light sources;

Fig. 3 exemplifies an imaging system (fundus camera) of the present invention utilizing coupling of many fibers into several rings;

10 **Fig. 4** exemplifies a system of the present invention utilizing mechanically exchangeable rings;

Figs. 5A and 5B exemplify a system of the invention utilizing a combination of LEDs of various operating wavelengths and a dichroic mirror;

15 **Figs. 6A and 6B** exemplify illumination systems utilizing diffractive and refractive optics, respectively;

Fig. 7 exemplifies a system of the present invention utilizing a light beam shaping arrangement configured for guiding light from a LED towards a region of interest;

20 **Figs. 8A and 8B** exemplify a system of the invention utilizing several light guides of similar design for several LEDs;

Fig. 9 exemplifies the configuration of a LED arrangement with a ring-like shape topology of LEDs suitable to be used in the present invention to increase the system efficiency;

25 **Fig. 10** exemplifies a system of the present invention utilizing an integrating sphere as a light source;

Fig. 11 exemplifies an integrating sphere with a light-guide suitable to be used in the present invention;

30 **Figs. 12A and 12B** exemplify an optical device configured as an "adaptor" unit for use with a LED arrangement in the system of the present invention;

- 12 -

Fig. 13 exemplifies a system of the invention utilizing a spectral filter configured as a dual spectrum barrier filter;

Figs. 14A and 14B illustrate, respectively, the characteristics of a dual spectral barrier filter for both the FA and ICG emissions, and the spectral characteristics of this filter with respect to the typical fluorescein absorption and emission spectra;

Fig. 15 illustrates a block diagram of a control system for use with the system of Fig. 1A.

Figs. 16 and 17 exemplify the principles of the invention for automatic exposure approach;

Fig. 18A exemplifies a method of the invention used for controlling modification of different exposure parameters; and.

Fig. 18B shows an example of a non-linear dependency of pixel intensity on the number of photons hitting the detector.

15 DETAILED DESCRIPTION OF EXEMPLARY EMBODIMENTS

Referring to **Fig. 1A** there is illustrated, by way of a block diagram, the main functional elements of a system **10** of the present invention suitable to be used in a fundus camera. System **10** includes a light source unit **12**, including a light source assembly **12A** formed by one or more LED-based units (each including a single LED or a LED-array) and a light beam guiding arrangement **12B**. Also provided in system **10** is a light directing optics **14** and an image detector **18**. System **10** is associated with a control system **19** configured for controlling various operational modes of system **10** as will be described more specifically further below.

25 Light beam guiding arrangement **12B** is configured for coupling light from the LEDs and providing output light beam(s) of a desired shape. For example, the light guiding arrangement is configured to provide a ring-like shaped light output therefrom. It should be noted that the light beam guiding

- 13 -

arrangement may be part of the light source assembly, or may be a separate assembly.

Light directing optics **14** includes lens arrangement (including an objective lens arrangement and an imaging lens arrangement) and a beam divider. Light directing optics **14** is configured and operable to collect and direct the ring-shaped illuminating light to an eye region **16** (constituting a region of interest), and collect and direct light returned (reflected and/or excited) from the illuminated eye fundus to an image detector **18**.

Fig. 1B illustrates a specific but not limiting example of the configuration of the above-described optical system layout **10**. The system is designed to enable to meet the requirement of the high quality illumination of the eye fundus. System **10** includes a LED-based light source unit **12** including a light guide **101**, a LED assembly **100** attached to one end of the light guide, and a lens arrangement **102** (presenting an entrance pupil **105**) appropriately accommodated at the other end of light guide unit **101**. Light guide unit **101** is configured as a cone-like reflector as will be exemplified further below with reference to Figs. 12A-12B. In the present example, LED assembly is configured to generate light of Red (R), Green (G), Blue (B) (or preferably Cyan as will be described further below) and White colors. It should, however, be noted that the invention is not limited to the use of these colors and can be employed with less or additional colors as required by a specific application.

The LEDs illumination is usually not homogeneous, both spatially and angularly. Also, light emitted by LEDs is spread over large angles that may reach 180 degrees without passing through any lens arrangement. The system of the present invention is aimed at providing substantially homogeneous illumination of a region of interest (fundus) while utilizing such non-homogeneous illumination from the LEDs. To this end, light guide unit **101** is configured such that at the entrance pupil **105**, the angle of a light beam emitted by the LED arrangement decreases into a cone of about 20 degrees or less. Namely, highly

- 14 -

efficient light guide unit **101** collects large proportion of the light energy from the LEDs arrangement into such a beam cone.

Lens arrangement **102** includes a condenser lens **102A** and a field lens **102B**. The configuration and operation of such lenses are known *per se* and therefore need not be specifically described, except to note the following: A condenser lens is a large lens typically used in an optical projecting system to collect light, radiated from a light source, over a large solid angle and to direct this light onto an object (or transparency) that is to be focused at a certain distance by a projection lens. A field lens is typically placed in or near the plane of an image to ensure that the light to the outer parts of the image is directed into the subsequent lenses of the system and thus uniform illumination over the field of view is ensured. Lens arrangement **102** at the output of the light guide unit **101** thus creates another pupil which is the image of the exit pupil **105** at an interface plane **104** (where a combiner mirror **104A** is located, being in the form of a mirror with a hole of a diameter that corresponds to that of the ring-like illumination, and also to the magnification factor of an objective lens arrangement). It should be noted that the term "hole" used herein signifies either an aperture (optical window) or a partially transmitting and reflective region. The latter allows for directing higher amount of energy towards the region of interest.

Lens arrangement **102** also includes a relay lens assembly **102C** and an objective lens arrangement **108**. Relay lens **102C** is appropriately accommodated between field lens **102B** and interface plane **104**, and projects an intermediate image **106** onto an intermediate image plane **107** in front of objective lens arrangement **108**. The latter focuses this image onto the region of interest **16** (fundus of the eye, represented here by an eye model).

Light returned from the illuminated region is collected by the same objective lens arrangement, passes through the hole (not shown here) in mirror **104A** and then processed by an imaging optics (not shown here). Plane **104** serves as a common pupil for both the illumination and imaging channels, thus ensuring their full coherence and presenting the ideal interface between them. As

- 15 -

indicated above, light combiner (mirror) **104A** is placed in the reference plane **104**, and is formed with a hole of a diameter that corresponds to the eye pupil size and the objective lens **108** magnification factor, such as to enable passage of the collected returned light (indicative of a retina image) therethrough and onto
5 the imaging optics.

The above-described configuration of the illumination system ensures full coherence with imaging optics represented in the layout of **Fig. 1B** by the common objective lens arrangement **108**. Also, this configuration ensures that the entire light produced by the LED arrangement enters the eye's pupil. This
10 configuration and the use of LEDs lead to fundus illumination that is far more homogeneous both spatially and angularly than that used in the existing fundus cameras.

The following are various examples of implementing technique of the present invention, enabling the use of LED-based light sources in a fundus
15 camera. To facilitate understanding, the same reference numbers are used for identifying those components that are common in all the examples of the invention.

Fig. 2 exemplifies a light source unit **112** of the present invention configured to couple light from many LEDs into an optical fiber ring. **Fig. 2** also
20 shows an imaging channel **20** associated with such light source unit **112**. In the example of **Fig. 2**, multiple LEDs **100A-100E** are coupled to a fiber bundle defining a ring-like light output along a ring-like member **21** and an imaging path defined by an aperture **23** of this ring-like member. This technique allows for collecting light from a LED in a commercially available package (like SMT, TO-
25 can or other package type), which is typically much larger than the active area of the LED-chip used for illumination, into a fiber with an active core of small dimensions.

As shown in the present example, light emitted by LED **100A** is coupled to its associated fiber **25A** via a lens **27**, while the other LEDs **100B-100E** are
30 commercially available fiber-coupled LEDs. The opposite ends of all the fibers

- 16 -

25A-25E are arranged so as to define a ring-like light output 26. These fibers' ends are packed in ring 21 with certain inner and outer diameters D_1 and D_2 . Light from ring 21 is imaged on the cornea of eye 16 via an objective lens arrangement 108. Inner diameter D_1 of ring 21 serves as aperture 23 for transmitting light. returned from the region of interest (fundus of the eye), via objective lens arrangement 108 and an imaging optics 24, to an image detector unit 18, which may be a CCD camera, eyepiece, film camera, LCD, etc. Preferably, the different wavelengths' channels (fibers) are arranged within the ring 21 such as to reach equal spectral distribution for as small as possible sub-section of the ring.

It should be noted although not specifically shown in the examples of the invention that imaging optics 24 may for example include focusing and relay lens arrangements. Preferably, according to the invention, image detector unit 18 includes two image detectors (live image camera and still camera), or preferably three image detectors (live image camera, still camera and monochrome camera, e.g., ICG-related camera) mounted such that at least some of them are selectively brought to the operational mode. In this case, imaging optics 24 preferably includes relay lens assembly for each camera, as well as a common relay lens assembly, and a common focusing lens arrangement.

The multiple LEDs' emitting light of different wavelength ranges can be used, for example Red, Blue, Green, White, and NIR, etc., and can be lit for each operation mode of the fundus camera. The operational include *inter alia* the following: FA, ICG, Red-free (Green), Red, Blue and Color Photography, as well as pulse (single pulse or pulse train) and/or continuous illumination. The inventors have found that for the FA, the use of exciting light of Cyan color and preferably within a specific wavelength range of 485nm – 500nm, provides the optimal excitation of fluorescein.

Turning back to Fig. 2, the use of multiple fibers allows for enhancing the brightness of illumination. The use of LEDs of different wavelengths allows for the ring operation in all the modes without the need for movement of any part.

- 17 -

The latter significantly facilitates operation of a fundus camera, as well as reduces the cost involved by adding a motor to move parts electronically.

It should also be noted that such a multiple-fiber coupler for the multiple LEDs eliminates the need for any beam combiner (mirror with hole) for combining the illumination and imaging channels; and the ring aperture can be used for the imaging path. Also, it should be noted that the above-described technique provides for coupling each LED to its associated fiber (rather than coupling a large LED or a LED-array to a fiber bundle consisting of a number of single fibers). As a result, the dead-area around each LED does not reduce the brightness. A cost effective option to implement this is by arranging the discrete LEDs in a matrix and coupling them with a lenslet array to a matrix of fibers, where each lens element of the lenslet array is dedicated to couple one LED to one specific fiber bundle.

Fig. 3 illustrates an imaging system **30** (fundus camera) of the present invention utilizing coupling of many fibers into several rings. This technique provides for achieving higher brightness than that obtainable with the configuration of Fig. 2, and utilizes a dichroic mirror for combining rings from various wavelengths. This provides a larger active area of the fibers dedicated for each wavelength channel, and thus more illumination power for each operational mode. This creates a larger set-up, and significantly higher illuminating power.

System **30** includes a light source unit formed by several fiber coupling rings (constituting LED assemblies with their associated light beam shaping assemblies), three such rings **21A**, **21B** and **21C** in the present example; wavelength-selective splitter/combiners (dichroic mirror) **31** and **32**, and condenser lenses **33A-33C** associated with rings **21A-21C**, respectively. Light portions L_1 and L_2 from rings **21A** and **21B**, respectively, are combined by dichroic mirror **31**, which transmits light in a spectral range of 750-800nm and is highly reflective to a 400-700nm spectral range. The so-produced combined light beam L_4 is then coupled with a light portion L_3 from ring **21C**, by dichroic

- 18 -

mirror **32**, which is highly reflective and transmitting for wavelengths, respectively, below and above 500nm.

This technique is thus generally similar to that of Fig. 2, but concentrates light of one or more wavelengths (each wavelength corresponding to a specific mode of operation) in a special ring. More specifically, Blue or Cyan LED for FA is concentrated into ring-like light source **21C**, a white or RGB light - into ring-like light source **21A**, and 790nm light for ICG or NIR illumination - into ring-like light source **21B**. This also allows for creating a white or RGB color ring by combining the RGB ring, in which blue color is typically of relatively low power thus presenting the so-called "white minus blue" ring at high power, with a separate high-power blue LED. Hence, blue color can be enhanced by utilizing the additional blue LED. More specifically, this is achieved by lighting white (RGB) ring **21A** with higher intensity and lighting blue ring **21C** (even with lower intensity) thus forming a controlling tool of the white light spectrum and intensity.

As further shown in **Fig. 3**, light portions L_1 - L_3 of rings **21A-21C** are imaged via lenses **33A-33C**, respectively, on a combiner **34**. Here, the light is re-imaged via an objective lens arrangement **108** on the region of interest (fundus) **16**. Light reflected or excited (fluoresced) from the fundus of the eye is imaged via objective **108** and an imaging optics **24** onto an image detector **18**.

Fig. 4 exemplifies a system **40** of the present invention utilizing mechanically exchangeable rings. This configuration, although requiring the ring movement for changing the operational mode of the system, provides for even higher brightness, since it does not need any beam splitters that absorb part of the energy transmitted through (or reflected from) them.

System **40** includes a light beam shaping arrangement in the form of light collecting rings **21A**, **21B** and **21C** (similar to the above-described system **30**), each corresponding to a specific illumination mode (such as FA, ICG, etc.). These rings are located on a wheel **42**, which is driven for rotation, and optionally contains an additional ring (to form an additional ring-like light

- 19 -

source) **21D**. To select for operation a certain illumination mode, wheel **42** is rotated to a position thereof to locate the operative one of the rings **21A-21D** between an imaging optics **24** and an objective lens arrangement **108**. Hence, the active ring operates as described above with reference to **Fig. 2**. Rotation of the wheel **42** sequentially brings one of rings **21A-21D** to its operative (active) position.

Reference is made to **Figs. 5A and 5B** showing a system **50** of yet another example of the invention utilizing a combination of LEDs of various operating wavelengths and a dichroic mirror. This configuration achieves higher brightness and allows for operating a white source by combining a blue source at low power with a "white minus blue source" at higher power. In this configuration, the optics are inexpensive, straight-forward and easy to design.

As shown in **Fig. 5A**, light from a LED or LED-array **100A** is focused by a lens **33A**, and optionally further passes through a filter **52A**, onto a plane where a ring-shaped mask assembly **54** is located. This mask assembly can include a set of different masks (different patterns), e.g., having different inner and/or outer diameters. As exemplified in **Fig. 5B**, this may be spaced-apart differently patterned regions **54A** and **54B** of a common substrate **55**: region **54A** acts as a mask with inner and outer diameters **56A** and **56A'**, and region **54B** that acts as a mask with inner and outer diameters **56B** and **56B'**.

By displacing substrate **55** with respect to the light propagation path, a different mask (one of regions **54A** and **54B**) is brought to an operative position, i.e., affects the light by applying beam shaping thereto. Substrate **55** may be glass or other optically transparent material, patterned by chrome or other non transparent coating, thereby defining a mask in the form of a pattern of light transmitting and blocking regions.

A light portion L_1 emitted by LED or LED-array **100A** (being a Blue LED) is combined with a light portion L_2 from LED or LED-array **100B** (being RGB/White light) by a dichroic mirror **31**; and is further combined with a light portion L_3 from a light source **100C** (NIR spectrum) via a dichroic mirror **32**.

- 20 -

Light source **100C** may be LED or laser diode. It should be noted that light source **100B** is positioned upstream (with respect to the light propagation towards an eye) of mask **54** and a mirror **34** (mirror with hole). The illuminating light therefore cannot shine in full brightness in the eye, and damage threshold will not be reached. The advantage of using a laser diode is its high brightness (typically higher than that of LED). If the white LED based channel **100B** cannot operate the R, G and B colors separately, a frequency selective filter unit (filter wheel) **52B** containing R, G and B filters is used, being accommodated in the optical path of light emerging from light source **100B**. The ring-form light from mask **54** is imaged via an imaging lens arrangement **57** onto the reflective surface of mirror **34**. Further propagation scheme of the illuminating light, as well as that of the returned light, is similar to that described above with reference to Fig. 3.

Figs. 6A and 6B exemplify illumination systems **60A** and **60B** utilizing diffractive and refractive optics, respectively.

System **60A** uses a diffractive element **62A** for high efficient coupling of Lambertian light into a ring. Such a diffractive element may be diffractive axicon or diffractive-type micro-prism array. The use of diffractive axicon element provides close to 100% coupling of light in case the incoming light is collimated. To this end, the light source unit preferably includes LEDs.

Light L_1 (Blue or Cyan) from a LED or LED array **100** is collimated by optics **33** and is projected via diffractive element (axicon or prism array) **62A** on a combining mirror with a hole **34**. Other light channel(s), if used, may be combined via one or more dichroic mirrors as described above (single such mirror **31** being shown in the present example). The illuminating light continues its propagation to an eye **16**, and returned light is directed to an image detector **18** as described above.

System **60B** is similar to the above-described system **60A**, but uses a refractive optical element **62B** for high efficient coupling of Lambertian light into a ring. Refractive optical element **62B** is either refractive axicon or refractive-type prism array. The refractive axicon, although being larger and

- 21 -

possibly more expensive when replicated in high volume, requires less tooling charge and is less wavelength-dependent than the diffractive alternative.

It should be noted that the diffraction/refraction of a micro-prism array can be optimized, such that light at each position on the array is
5 diffracted/refracted in a way optimal for that position. It should also be noted that it is relatively easy to manufacture a refractive micro-prism array of large refraction angles, typically larger than the angles achievable with a diffractive micro-prism array.

Reference is made to **Fig. 7** exemplifying an optical system **70** utilizing a
10 light beam shaping arrangement in the form of a light guide for guiding light from a LED towards a region of interest. This technique provides for coupling light of a LED, emitting light at a large angle, by a light guide that guides this light into a small ring or into a predetermined beam cone. The ring can be enlarged to reach the required dimensions on a combining mirror (mirror with
15 hole) and decrease the angle of the light cone accordingly. This advantageously allows for collecting light from the guide in large angles by an objective lens arrangement that is by itself capable of collecting light impinging thereon in a small cone.

System **70** includes a LED assembly **100A** (single LED or LED array); a
20 light guide **101A** configured to provide, from light emitted by the LED arrangement, ring-like illumination at the output of the light guide; a lens arrangement **33A** for imaging light emerging from the light guide onto a combining mirror **34**. As also shown in the figure, the system may include several additional LEDs assemblies with their associated light guiding units and
25 optics. More specifically, in the present example, the LEDs arrangement includes three LED assemblies **100A**, **100B** and **100C**, associated with three light guides, respectively (only one such light guide **101A** being shown in the figure), and three lens arrangements **33A-33C**. Dichroic mirrors are appropriately provided: dichroic mirror **31A** combines light portions L_1 and L_2 from LEDs **100A** and
30 **100B** producing a combined light beam L_4 ; and dichroic mirror **31B** combines

- 22 -

this combined light beam **L₄** and light **L₃** from LED **100C** into a further combined light beam **L₅**. The latter is directed by mirror **34** towards an eye **16** via an objective lens arrangement **108**. Light **L₆** returned from the illuminated region in the retina (and indicative of the image of the illuminated region) is
5 collected by objective **108** and transmitted by mirror **34** towards an imaging lens **24** which relays the image onto an image detector **18**.

Reference is made to **Figs. 8A and 8B** exemplifying a system **300** of the invention utilizing a common light guide for several LEDs. This technique provides for coupling light from a number of LEDs into a single light guide that
10 collects all the light into a single ring.

As shown in **Fig. 8A**, system **300** includes a LED arrangement formed by several LEDs assemblies **100A**, **100B** and **100C**; and an optical system including condenser lens arrangements **33A-33C** associated with LEDs assemblies **100A-100C**, dichroic mirrors **31A** and **31B** operating together to combine light portions
15 **L₁÷L₃** from the LEDs assemblies; a combining mirror (mirror with hole) **34**; and objective and imaging lens arrangements **108** and **24**. As shown in **Fig. 8B**, the LEDs assembly (assembly **100A** being shown in the figure) includes LEDs **302** and **304** associated with a common light guide **306**. Light from LEDs **302** and **304** is guided to a ring-like form at the output **307** of the light guide **306**.
20 Optionally, an inner surface **308** of the light guide is coated with glossy or diffusive reflective material, such as Silver, Aluminum, to enhance the illumination efficiency. The light guide body **306** may be made of PMMA or other plastic or glass material.

It should be understood that the use of additional LEDs assemblies (**100B**
25 and **100C**) with their associated optics is optional. The system may utilize either one large light guide containing LEDs of all the colors, or couple them with other channels via dichroic mirrors as shown in **Fig. 8A**. Light guide **306** can either encapsulate the LEDs to reach higher efficiency as shown, or circumvent the LEDs as is common practice in the art (not shown).

The above-described technique uses light from more than one LED and can reach therefore higher brightness, although it requires a more complex light guide than that described above with reference to Figs. 8A-8B.

Reference is made to **Fig. 9** exemplifying the configuration of a LED arrangement suitable to be used in the system of the invention. This technique utilizes the topology of LEDs in a ring-like shape to increase the efficiency. Here, a system **400** is shown configured generally similar to the above-described examples, namely including a LED arrangement **100**, an annular mirror **34**, an objective lens arrangement **108**, and an imaging optics **24**.

In the present example, LED arrangement **100** is in the form of a ring-like shaped structure **401** containing LEDs within its borders of an inner diameter **402** and an outer diameter **403**, thus creating a ring-like shaped light source formed by a number of LEDs arranged in a circular array. Optionally, locally adjacent LEDs **406A** and **406B** contained in the array have different emitting spectra and/or power, or the LEDs array contains different groups of LEDs, each group having about the same spectrum and/or power. Each type of LED can be of a spectrum optimized for a specific operational mode, like FA or ICG. It should be noted, although not specifically shown, that several such rings **401** can be combined by dichroic mirror(s) as described above, to make an overall brighter ring that has a more uniform spectral and/or power distribution.

Also, optionally, at least some of the LED's can be associated with a condensing element to narrow the emitting angle and/or associated with a diffusing element to make the source more uniform. Additionally or alternatively, one or more micro lens arrays **408** may be used to condense and/or diffuse light emitted by some or all of the LEDs in the array. The micro lens array **408** may be put close to the ring **401** and designed such that each lens element **410** is optimized to collect light from one LED chip; and/or another micro lens array **412** may be placed a bit further away and having lens elements optimized to collect light from the obtained light distribution in the plain it is positioned.

- 24 -

Light emerging from the lens array(s) can optionally be further condensed and/or imaged by lens assembly **414**, and may or may not then pass through an optical filter or filter-set **416** to narrow the spectrum of light. Ring **401** will be further imaged on mirror **34** and via objective lens assembly **108** on eye **16**. The
5 reflecting or fluorescing light from the eye **109** is imaged by objective lens assembly **108**, onto mirror **34**, and then re-imaged by ocular lens assembly **24** on an image detector **18** (which may be a CCD camera, eye-piece or similar target).

Fig. 10 exemplifies an optical system **600** utilizing an integrating sphere. According to this technique, light that does not emerge from a ring is recycled by
10 internal reflection in the integrating sphere and has a large probability to exit the sphere at the ring after one or more reflections in the integrating sphere. This enables to reach a higher coupling efficiency. System **600** includes a LED arrangement formed by a single LED assembly **100A** and its associated light directing optics (condenser **33**, mirror with hole **34**, objective lens **108**, imaging
15 lens **24**), or also including one or more additional LED assemblies (two such assemblies **100B** and **100C** being shown in the present example) in which case dichroic mirror **31** and **32** are appropriately provided for combining light from all the LED assemblies and directing combined light to mirror **34**.

The LED assembly is formed by an integrating sphere or chamber **602** in
20 which LEDs or LED arrays are mounted: the legs of LEDs pass through holes **604** to the outside where they can be connected to a current source (not shown). Another option to connect LEDs or LED arrays **606** to the wall on position where the wall consists locally of conductive material **608**, or yet another option is used where the LED's are mounted in the sphere (not shown). Light emitted from the
25 LED can bounce many times against the highly reflective holes and leave via a window **610**. An inner ring **612** of the window can be coated with a reflective material, or an external mask **614** can be positioned to cover the inner diameter of the window, creating a ring-like shaped light-source with inner and outer diameters **616** and **618**. The wide angle of radiation coming out of the window
30 **610** can be narrowed by optics **33A** (or **33B**, **33C**) that enlarges the size of the

- 25 -

ring on mirror **34** and narrows its radiation angle. The integrating sphere can contain light from all channels, or the channels can be combined via dichroic mirrors **31** and **32** as described above.

Fig. 11 exemplifies an integrated sphere with a light-guide suitable to be used in the present invention. According to this example, light from a sphere configured as described above is guided via a light-guide, aimed at narrowing the exit angles of the ring and matching them with those that can be accepted by the objective. More specifically, inside an integrating sphere or chamber **702** LEDs or LED arrays are placed with their legs passing through holes **604** to the outside where they can be connected to a current source (not shown); or LEDs or LED arrays **606** are connected on the wall on position where the wall consists locally of conductive material **608**; or the LEDs are mounted in the sphere (not shown). The emitted light can bounce many times against the highly reflective holes and leave via a window **710** or an open space. The window can be coated with reflective material creating a ring form aperture with inner diameter **716** and outer diameter **718**.

The wide angle of radiation coming out of the window **710** can be narrowed by placing a light guide **720** after this aperture that guides the light from a narrow circle aperture with inner diameter **722** and outer diameter **724**, to a wider ring with an inner diameter **722'** and an outer diameter **724'**. The light guide **720** is designed such that at its output side light exits in a ring-like shape and has a narrow divergent angle. To enable modification of the inner and outer diameters of the ring needed for myd versus non-myd or large versus small pupil exposures, the inner and outer diameter of the exit ring can optionally be resized by placing a mask **730** at its output side that hinders light, outside its outer diameter **732** and outside its inner diameter **734**, to pass therethrough. This mask can be removed or moved and replaced by another mask or a transparent window **740** that will allow the entire ring-shaped light from the light guide to pass therethrough. The non-transparent part of the mask can optionally be reflective,

- 26 -

so that light reflected to the light guide and/or sphere can arrive within the desired ring-like shape after one or more reflections.

As assembly **750** formed by integrating sphere **702** with light guide **720** can contain light from all channels or the channels can be combined via dichroic mirrors as described above. Alternatively, a light guide can be designed so as to contain a part like the sphere described above with reference to Figs. 8A-8B, and a part like the light guide described below.

Reference is now made to **Figs. 12A and 12B** exemplifying an optical device configured as a so-called "adaptor" unit **200** for use with a LED arrangement in the system of the present invention.

Optical device **200** is formed by a light guide **101** and its associated optics. Device **200** includes a lens arrangement formed by a condenser lens **33** and an additional identical condenser lens **33'**; and a dichroic mirror **31** inclined at 45 degrees with respect to a light path. A LED arrangement **100** includes two types of LEDs (or LEDs arrays): LED **100A** emitting light at about 760-800nm (NIR LED) and "visible" LEDs **100B**. Each LED is assembled on a light guide configured as a cone-like reflector (e.g., a "Compound Parabolic Concentrator" - CPC). Such a light guide unit is a hollow cone-like member with its inner surface reflective with respect to a wavelength range emitted by a LED arrangement to be used with this light guide unit. Generally speaking, the geometry of such a reflective light guide unit (i.e., its inner diameter function and its length) defines the output light beam characteristics (e.g., homogeneity and divergence angle). The light guide unit is permanently attached to a LED selection unit (e.g., wheel **207**) such that the light exit of the light guide unit is located at the entrance pupil of unit **200**, and is designed to fit a LED mounted on its other end in order to optimize the efficiency of light collection. As shown in **Fig. 12B**, LED(s) **100A** is associated with CPC **101A**, and LED(s) **100B** is associated with CPC **101B**.

Unit **200** is configured to select one LED from a multiple "visible" LEDs for the operational mode of the system. In the present example four such visible LED units (LED with its light guide) are shown (**Fig. 12A**). In the present

- 27 -

example, the selection of light source (LED) is realized by using a wheel (gear driven) **207** that is motorized by a motor and gear arrangement **208**. The LED selection is controlled through a control unit and a digital interface on a controlling electronic circuit (which are not shown here). A common field lens
5 **102B** is assembled at the third portion (exit) of unit **200** through which an illumination beam is directed into an optical system (described above) that directs the illumination beam towards the eye fundus through an objective lens arrangement (not shown here).

The selectable LEDs are all in the visible range. Therefore, dichroic
10 mirror **31** reflects this visible light from LEDs **100B** and transmits light from the NIR LED **100A**. The selectable light sources contain at least white, blue, green, red LED sources.

The optical scheme of unit **200** is illustrated more specifically in **Fig. 12B**. As shown, visible LEDs' units (three of them being seen in the figure) are
15 mounted on rotatable wheel **207**. Light L_1 from LED **100B** is guided through CPC (reflector) **101B** towards condenser lens **33** (optionally through an FA excitation filter **211**) and further towards dichroic mirror **31**. NIR light L_2 from LED **100A** is guided through its associated CPC **101A** to condenser lens **33'** (optionally through an ICG excitation filter **211'**) which directs this light onto
20 dichroic mirror **31**. The latter combines light portions L_1 and L_2 , and combined light L_4 is collected by common field lens **102B**.

The above-described configuration, on the one hand, provides for aligning the NIR LED **100A** illumination of the system (camera) to the patient's eye, thus enabling the so-called Non-Mydriatic mode (for non-dilated pupils), and also
25 allows general use of the system without irritating the patient's eye with continuous visible light. On the other hand, the above configuration provides a fundus camera with the ICG option, where NIR LED **100A** is being utilized as a flash LED at high intensity. The selectable light source stands-by for the flash illumination and photo – for all other procedures.

- 28 -

Where required, a bandpass or cut-off filter (excitation filter) **211** is incorporated as an integral part of each light source sub-assembly. Specifically, such filters are incorporated with the LED that illuminates light for the FA procedure, and with the NIR LED when used for the ICG procedure.

5 According to some other aspects of the invention, it provides for fast and effective FA and ICG imaging in a concurrent or quasi-concurrent fashion. In this situation, a patient is injected with both ICG and fluorescein agents, and either concurrent or consecutive images will be acquired by operating the FA-wavelength LED in a flash mode and operating the ICG-wavelength LED in a
10 flash mode, correspondingly. This feature of the invention provides for solving a long-felt need for ophthalmologists to diagnose simultaneously (in the same examination session) various pathologies in the retina. This feature can be achieved due to the use of a novel design of the above-described adaptor unit **200** (needing no moving parts during the session, i.e., upon selecting desired LED
15 units) and by incorporating therein a novel filter assembly. In this connection, reference is made to **Fig. 13** exemplifying an optical system **800** of the invention utilizing a spectral filter (preferably configured as a dual spectrum barrier filter) **802**.

System **800** includes a LED arrangement **100** with its associated optics
20 directing light towards an annular mirror **34**, an objective lens arrangement **108** in the optical path of incident and returned light, and an imaging channel formed by mirror **34**, imaging optics including first and second relay optics **102C** and **102C'**, and a spectral filter **802**. LED arrangement **100** includes a NIR LED unit including a NIR LED (or LED array) **100A** and its light guide (CPC) **101A**, and
25 a visible LED unit including a visible LED (or LED array) **100B** and its light guide (CPC) **101B**. A dichroic mirror **31** combines light from LEDs **100A** and **100B** and directs combined light towards a field lens **102B**, and a relay lens **103**, and then onto a mirror **804** which reflects this light onto annular mirror **34**.

Filter **802** may be configured to transmit the emitted fluorescent light from
30 the eye's fundus towards an image detector unit **18**, while blocking the excitation

illumination spectrum thus being operative while in the FA mode. In this case, the FA barrier filter **802** is displaceable between its operative position (in the optical path) and inoperative position (out of the optical path) and can be replaced by the ICG barrier filter in a consecutive manner.

5 As indicated above, filter **802** is preferably configured as a dual spectrum barrier filter, namely defines two spectral bandwidths corresponding to both the FA and the ICG procedures. This enables yet another operational mode of system **800**, namely taking a combined FA/ICG photo by applying both the visible and the NIR flashes substantially simultaneously (i.e., simultaneously or in a very
10 fast sequence) and directing the resulting image onto CMOS or CCD camera **18** which is sensitive to the spectral range of 400-850nm. This provides for a very effective diagnostic tool to ophthalmologists, enabling the observation of different layers of the retina and choroid in a single procedure.

Fig. 14A illustrates the characteristics of such a dual spectral barrier filter.
15 **Fig. 14B** shows the spectral characteristics of the filter with respect to the typical fluorescein absorption and emission spectra: graphs **G₁**, **G₂**, **G₃**, **G₄** and **G₅** correspond to, respectively, the excitation filter, barrier filter, fluorescein absorption, fluorescein emission, and LED emission. As shown, a relation between the LED and fluorescein absorption spectra is characterized by the
20 maximal congruency; a relation between the excitation filter, fluorescein absorption and LED spectra maximizes the energy (highest cut-off); a relation between barrier filter and fluorescent emission maximizes the energy (lowest cut-on); and the excitation filter and barrier filter spectra define a blocking zone (transmission less than 0.01%). The above relations are optimized by using an
25 optimization algorithm from which the LEDs and filters are chosen and designed accordingly.

The invention also provides for the system operation with a fast fluorescence mode. In the current state of the art, a fundus camera is capable of providing either a noisy live image or a flash (pulse) based fluorescence image in
30 a rate of up to 1 or 2 frames per second. The invention utilizes a pulsed light

- 30 -

source operable with high-frequency high-intensity light pulses (e.g., at a rate of 10 pulses per second), thus enabling creation of a pseudo live image with multiple-frames per second. In the optimum case, when this number reaches 30 frames per second and this pulse illumination is synchronized with the camera,
5 the same amount of images/second will be created as with a regular direct live image. The inventors have found that this is especially possible with LED's sources that can generate more than 30 pulses (flashes) per second. It is important to note that this cannot be achieved with a Xenon lamp illumination source.

10 The inventors have found that the high-intensity flash mode operation of a LED can be achieved by applying to the LED a controllable "pumping". This is implemented by applying pulses of high electric current while controlling the electric current maximal value so as not to exceed a predetermined threshold for a specific LED, on the one hand, and keeping the current pulses' shape stabilized
15 and controlled. Hence, the present invention provides for realization of high intensity light for a short flash duration. It is important to note that the technique of the invention utilizes pumping of the LED driving current to up to 12 times of its rating current (according to retailers' catalogues). This can be achieved since the duty-cycle of flashes may be very small (e.g., about 1/50), which permits
20 sufficient time for the LED junction to cool down prior to its next flash action. It should be understood that the flash rate and the flash duration are fully controllable to obtain the desired results (e.g., emitted energy). The current is limited in a fashion that will secure few years of service under the most demanding conditions.

25 The FA procedure uses fluorescein as a fluorescent material. Based on typical excitation spectrum and typical emission spectrum, the illuminating LED spectrum and the spectra of the excitation and barrier filters are adjusted in a manner that ensures both optimized energy utilization and blocking characteristics to ensure the highest dynamic range and thus the best diagnostic
30 ability from the resulting photos.

- 31 -

The present invention also provides a special mechanism for controlling a light compensation to regulate for ANSI regulations for maximal allowed light. This is implemented as follows: A part of the illumination light is coupled into a separate photodetector, such as a photodiode. The amount of light collected in this detector has a direct linear relation with the amount of light collected by the eye that can be simulated with a detector in the position of the eye, a so-called "eye-simulating detector". By measuring both the energy at the separate photodetector and at the eye-simulating detector, the output at the separate photodetector can be verified when the eye-simulating detector accumulates the maximum amount of light allowed according to the ANSI regulations. During normal operation, light accumulated on the separate photodetector is integrated on-line till it reaches the maximum amount allowed according to the ANSI regulations reduced by a certain safety margin. Then, this photodetector or a control unit associated therewith sends a trigger to stop the illumination (to switch off the illuminating device) using additional electronics and or software/hardware.

The present invention, in its yet another aspect, provides for automatic control of the exposure of a region of interest. This is associated with the following: Conventional fundus cameras utilize a film and/or still cameras to photograph various retinal objects. Some of the known fundus cameras utilize video cameras to observe real time images either as eye-piece ocular replacement, especially when a NIR light source (not observable by a human eye) is used, or as an additional image source.

Fig. 15 illustrates a block diagram of a control system **19** (referred to in Fig. 1A). Control system is an electronic assembly formed by a computer unit **19A** (e.g., a personal computer) and an illumination/imaging control electronics **19B** (specifically designed printed circuit board). Also provided in control system **19** are a camera exchange unit **19C** (configured and operable to shift between different cameras) and a multiple LED units' arrangement **12** (i.e., light source unit formed by LEDs and their associated light guides). PC unit **19A**

typically has a memory/storage utility **19C**, and according to the invention is preprogrammed with several models including *inter alia* a graphic unit interface **19D**, an application mode selector **19E**, auto-exposure control utility **19F** and an auto-focus utility **19G**.

5 It should be noted although not specifically shown that the control system may be configured to make a record for each patient regarding his specific imaging-related data (i.e., colorness/brigtness, vision diopters of each of the patient eyes and per application mode, patient eye properties such as eye class, regions of interest in the eye, etc.) and the corresponding patient identification
10 data. Hence, the present invention provides for recording the patient imaging-related data at his first examination, and for each further examination enables automatic selection of the exposure settings and focusing lens set per patient eye and clinical mode intended to be used in response to the patient ID data entry.

The present invention utilizes auto-exposure control utility **19F** providing
15 a mechanism configured and operable to set appropriate light exposure parameters (such as exposure time, illumination and camera gain) in either one of the application modes, and provides for analyzing the acquired images such as to optimize an image-related data taken by flash (pulsed) light imaging and/or continuous imaging. This can be implemented using default exposures, or by
20 automatic exposure according to the invention.

With regard to the default exposures, the following should be noted: As a fundus camera uses various fluorescent agents, times after injection and magnifications, the optimum illumination parameter strongly varies from application to application. Defining any desired amount of illumination common
25 for all the applications is practically impossible, but only a common wide range of illumination amounts can be defined. However, when using a specific fluorescent agent at a specific time after the injection and with a certain magnification, the range of optimal illumination can be significantly narrowed. Data indicative of desired (optimum) amount of illumination can be determined
30 by capturing images acquired with all the possible variations of input parameters

- 33 -

that include magnification, and/or fluorescent agent and/or time after the injection and possibly other data. This desired data combined with the input parameters can be used as reference data, e.g., in the form of LUT (Look-Up-Table). In an automatic illumination mode, software can be designed to use the
5 input parameters to select from the reference data the corresponding desired illumination amount and operate the exposure accordingly. After a time period (exposure time) needed to accumulate the desired amount of light, a CCD or CMOS detector receives a trigger to stop the light collection and/or illumination.

As for the automatic exposure, it can be of a first type consisting of the
10 following: Part of the desired excited (fluorescent) light is coupled into a separate photodetector such as a photodiode. The amount of light collected in this separate detector will have a direct linear relation with the amount of light collected on the CCD or image-capturing device. By analyzing the captured images, a range of light detected at the separate photodetector can be selected as corresponding to
15 well-illuminated images and over-illuminated images. Based on these analyses, the optimum desired light accumulated at the separate photodiode can be set to correspond to the well-illuminated images, and non-illuminated, or very little, over and/or under illuminated images. During normal operation, the light accumulated on the separate photodetector is integrated on-line, till it reaches the
20 optimum light level, and then a trigger signal is generated to stop the light capture and/or to stop the illumination, using additional electronics and/or software/hardware. Hence, controlling of the amount of light collected at the separate photodetector is used for managing the image acquisition procedure.

Another type of the invented automatic exposure technique utilizes the so-
25 called "feed forward" control technique. This consists of using images acquired with continuous and/or pulsed (flash) light mode for optimizing the exposure parameters for successive images of the same or different illumination mode. For example, live motion images observed by the continuous light (white, monochromatic at blue, green, red or NIR) are used as a predictor for the amount
30 of light exposure to be used in the flash (pulsed) light imaging.

- 34 -

Reference is made to **Fig. 16** illustrating a block diagram **900** exemplifying the above-described exposure techniques (auto-exposure control utility **19F** in **Fig. 15**). As shown, data portions indicative of images grabbed by a still image camera **901** and a live image camera **902** are entered into a control unit **903** configured for implementing an auto-exposure control mechanism. An application mode **906**, which is determined by user interface **907**, sets certain default exposure settings **908**, both for a flash light control **904** and for a continuous light control **905**. The default values are defined according to a study of the average needs of a patient eye. The auto-exposure control unit **903** is configured as a data processor unit (including software and/or hardware utilities) preprogrammed to analyze the grabbed images, for example by using an image histogram technique with certain parameters that are based on the current application mode **906** and a set of required contrast and density conditions for the image to be obtained. Based on these analyzes, the auto-exposure control unit **903** creates new settings to flash (pulsed) light control **904** and to continuous light control **905**. The operation of the auto-exposure unit can be stopped by using an appropriate on/off mechanism **909** operable by a certain default setting and/or manually via user interface **907**.

The above-described technique is *inter alia* suitable for certain applications with dynamic nature such as fluorescein (FA) or Indo-Cyanine-Green Angiography (ICGA), in which the photographic procedure requires a sequence of flash (pulsed light images. Successive images are studied to improve the image total exposure and contrast.

A specific but not limiting example of the above described technique will now be described with reference to **Fig. 16** showing a block diagram **1000** of the above concept. Patient & Image Meta-Data **1420** is created from all relevant data about a patient image. This relevant data is obtained during a learning mode and includes *inter alia* the following: description of an application mode **906** (e.g. color, RF, FA and ICGA, exposure settings, timing information for FA and ICGA application modes); patient eye properties **1422** (e.g., eye class, left/right

- 35 -

eye, regions of interest in the eye, etc.). These data portions **906** and **1422** may be obtained from user interface **907**, or via a recognition and interpretation module **1430**. The latter receives image-related data from cameras **901** (still image camera) and **902** (live image camera). Also the Meta Data **1420** may be based on
5 data coming from exposure settings controls **1403**, **1403A**, **1404**, **1404A**, as will be described further below.

With regard to the application mode data, the following should be noted. FA is commonly classified into the following phases according to time elapsed since fluorescein injection (typical durations appear in the literature): pre-arterial
10 phase, transit phase (arterial phase, laminar venous phase, full venous phase), recirculation phase, late phase. ICGA is commonly classified into the following phases according to time elapsed since ICG injection (typical durations appear in the literature): early phase, middle phase, late phase.

The Meta Data **1420** is then utilized in auto-exposure control mechanism
15 formed by units **903** and **903a** associated with the two cameras **901** and **902**. More specifically, images are obtained with both the still image camera **901** and the live image camera **902**; and similar auto-exposure processes are carried out for each camera independently, while both such auto-exposure processes taking advantage of the same Meta Data **1420**. The latter presents means for sharing
20 information between the two processing channels (pulse-like and continuous illumination based images).

Captured images (at least some of them), acquired by either one or both cameras **901** and **902**, are analyzed by dynamic range analysis algorithms **1401** and **1401A** which will be described further below. The output of these algorithms
25 serve as the input for exposure settings generators **1402** and **1402A** (also described more specifically further below), which translate the computer-level image processing parameters into system physical parameters that need to be set. These are transmitted to appropriate control units **1403**, **1403A**, **1404** and **1404A**. In this connection, the following should be noted: The exposure settings
30 generator (**1402**, **1402a**) utilizes data indicative of the exposure settings that were

- 36 -

used for the image acquisition (the image processed by dynamic range analysis algorithms **1401**, **1401a**). This could be achieved by "remembering" the last generated settings (as shown in the figure), or although not specifically shown, by getting this as input. The latter case can be implemented by getting this
5 info separately and in addition to the image and the meta-data, or by getting this info as part of the meta-data.

If or when a new image arrives, while the previous one is still being processed, the processing is not halted, but rather a request is placed in a queue or ignored. This allows auto-exposure to be carried out for fast image streams.

10 Recognition and interpretation module **1430** is configured and operable as follows: Images, taken by both the still and live image cameras **901** and **902**, are processed by this module. The algorithms of this module **1430** analyze the image contents and characteristics of objects in the image by utilizing any known suitable computer vision techniques. Output of these algorithms may be
15 indicative *inter alia* of left/right eye; locations of eye parts such as ONH, macula and blood vessels; eye class (according to a proper eye classification).

Dynamic range analysis algorithms **1401** and **1401A** consist of the following: Such algorithm analyzes the dynamic range exploited by the image, and compares it to a theoretical dynamic range (reference data or certain model).
20 Then, recommendations are produced for improving the image dynamic range. The recommendations are given by specifying a source intensity level (*src*) existing in the image, and a destination intensity level (*dst*) it should be translated into. For example, if the image is overexposed, a value of *dst* being less than *src* is expected. If the image is underexposed, *dst* being higher than *src* is expected.
25 Additional parameters may be reported by the algorithm, to indicate the recommended dynamic range improvements.

If the input image has three color channels (RGB), each channel is typically processed independently, and the results are fused together. Also, the algorithm may take advantage of accompanying meta-data, such as the location
30 of eye parts, and regions of interest in the image.

The dynamic range analysis algorithm might create a histogram of the image intensity level, and decide upon a criterion, according to which a certain percentage of the image pixels should have an intensity level greater than a certain percentage of the dynamic range. This criterion may be combined with other requirements such as paying attention only to a certain region of interest.

If the image is saturated, the dynamic range analysis algorithm might choose *src* and *dst* according to the percentage of image pixels which are saturated, utilizing a given LUT. For example, keeping *src* as the 100% dynamic range intensity level, *dst* will be set to an intensity level proportional to the percentage of non-saturated image pixels.

The dynamic range analysis algorithm may perform linear and/or non-linear pre-processing of the image.

The dynamic range analysis algorithm may also analyze the noise level in the image and pass the results on to the Exposure Settings Generator (1402 and 1402a) for consideration. If the noise source has been identified (such as electronic noise or reflectance), the appropriate exposure settings parameters are altered to reduce the noise level in the image. A search method may be used to find the optimal exposure settings (i.e., those providing best combination of good dynamic range and low noise), even if these settings differ from those imposed by the priority LUT (reference data).

Exposure settings generators 1402 and 1402A are configured and operable as follows: After recommendations have been produced for improving the image dynamic range, they are translated into recommendations for improving the exposure settings of the fundus camera system. These typically include: illumination brightness, exposure duration assuming full illumination, and electronic gain. It should be understood that the phrase "*exposure duration assuming full illumination*" refers to the exposure duration of flash imaging when a camera shutter is open and flash is illuminating, simultaneously. The exposure settings generator is aimed at: controlling the modification of the different exposure parameters, by following given prioritizing guidelines, thus enabling to

- 38 -

achieve the best image quality, best patient comfort, and/or other goals; and selecting the optimal exposure settings in order to minimize, or even eliminate, the need for recurrent exposure corrections.

The control of the modification of different exposure parameters is achieved by using LUTs and/or logics describing the priorities of the exposure parameters. Priorities are described for each pair of camera and fundus separately. **Fig. 18A** shows an example to provide this information. Here, the horizontal axis needs not be of a consistent scale, as an iterative calculation is carried out each time.

The selection of the optimal exposure settings is achieved by knowing the effect of the exposure settings on the captured image. All relevant characteristic behaviors of the camera and/or fundus are given as LUTs or integrated into the logic of the exposure settings generator. **Fig. 18B** shows an example of a non-linear dependency of pixel intensity on the number of photons hitting the detector.

In some cases, default exposure settings **908, 908A** are used according to given meta-data. The default exposure settings might also limit the range of the automatically calculated exposure settings or be weighted together with them. The exposure settings generator may use history-data saved in dedicated memory locations **1406** and **1406A**, in order to achieve better stabilization and/or minimization of the number of recurrent cycles needed for achieving proper exposure.

Thus, the present invention provides for a novel effective configuration of an imager, particularly useful as an integrated retina imager, and method of its operation and control.

Those skilled in the art will readily appreciate that various modifications and changes can be applied to the embodiments of the invention as hereinbefore described without departing from its scope defined in and by the appended claims.

CLAIMS:

1. A system for use in imaging the patient's retina, the system comprising:
(a) a light source unit comprising a light emitting diode (LED) arrangement comprising multiple LEDs of different wavelength ranges; (b) a light guide
5 arrangement configured for coupling light from the LEDs and providing output light beams of a desired shape; (c) a light directing optics for directing the light beam towards a region on the retina and for collecting and directing light returned from the illuminated region to an image detector unit.
2. The system of Claim 1, wherein the light source unit is configured for
10 producing at least one ring-like shaped light beam.
3. The system of Claim 1 or 2, wherein said LED arrangement comprises at least one LED emitting light in a near infrared spectral range.
4. The system of any one of preceding Claims, wherein said LED arrangement comprises at least one LED emitting light in a visible spectral range.
- 15 5. The system of any one of preceding Claims, wherein the light source unit comprises at least one laser diode.
6. The system of any one of preceding Claims, wherein the LED arrangement generates light of at least Red, Green, Blue and White colors.
7. The system of any one of preceding Claims, wherein the light directing
20 optics includes an objective lens arrangement, and an imaging lens arrangement.
8. The system of Claim 7, wherein the light directing optics comprises a condenser lens arrangement in the optical path of light emitted by the LED arrangement.
9. The system of Claim 7 or 8, wherein the light directing optics comprises
25 a field lens arrangement in the optical path of the illuminating light.
10. The system of any one of Claim 7 to 9, wherein the light directing optics comprises a relay lens arrangement in the optical path of the illuminating light.

- 40 -

11. The system of any of preceding Claims, wherein the light guide arrangement comprises one or more light guide unit each configured as a cone-like reflector.

12. The system of Claim 11, wherein the light guide unit has a parabolic-like curvature of its inner reflective surface.

13. The system of Claim 11 or 12, wherein the light guide unit is configured to provide the illuminating light beam cone of about 20 degrees or less at the output of the light guide unit.

14. The system of any one of preceding Claims, wherein the light guide arrangement comprises optical fibers each configured for coupling light from each of the multiple LEDs, thereby allowing for enhancing the illuminating light.

15. The system of Claim 14, comprising a ring-like member carrying ends of the multiple fibers arranged along said ring-like member, the opposite ends of said fibers being coupled to the LEDs, respectively, thereby defining the ring-like light output from the ring-like member, and defining an imaging channel by a central hole of the ring-like member.

16. The system of Claim 15, wherein at least one of said LEDs is coupled to its associated fiber via a lens arrangement.

17. The system of Claim 15 or 16, wherein the different wavelengths' fibers are arranged within the ring-like member so as to reach substantially equal spectral distribution for as small as possible sub-section of the ring-like member.

18. The system of any one of Claims 14 to 17, wherein the LEDs are arranged in a matrix, and are coupled to their dedicated fibers, respectively, via a lenslet array, where each lens element of the lenslet array is dedicated to couple one LED to one fiber.

19. The system of any one of Claims 14 to 17, wherein the LED arrangement comprises at least two LED assemblies, each LED assembly being formed by the multiple LEDs coupled via the fibers, respectively, to the ring-like member; the system comprising a wavelength-selective arrangement including at least one

wavelength-selective filter for combining light from said at least two light assemblies.

20. The system of Claim 19, wherein the LED arrangement comprises three said LED assemblies for generating respectively white light, near infrared light, and Blue light, said wavelength-selective arrangement comprising a first wavelength-selective filter configured to transmit the near infrared spectral range and being highly reflective for the Blue spectral range, and a second wavelength-selective filter configured to be highly reflective for the Blue light and transmitting for the near infrared light.

10 21. The system of any one of Claims 14 to 18, wherein the LED arrangement comprises at least two LED assemblies, each LED assembly being formed by the multiple LEDs coupled via the fibers, respectively, to the ring-like member; said ring-like members being mounted on a rotatable wheel, the rotation of the wheel selectively locating one of the ring-like members in the illuminating optical path.

15 22. The system of any one of preceding Claims, wherein the light directing optics comprises a beam combiner in the form of a mirror with hole for reflecting the illuminating light by its periphery reflective region, and transmitting the returned light through the central hole.

23. The system of Claim 22, wherein said hole has a dimension defined by the eye pupil size and a magnification of an objective lens arrangement.

24. The system of any one of Claims 2 to 23, wherein an aperture formed by said ring-like shaped light beam defines an imaging channel for said returned light propagation.

25. The system of any one of Claims 2 to 24, comprising a mask assembly located in the optical path of the illuminating light, said mask assembly being configured to define at least two masks of different patterns, each pattern defining a ring-like shaped light transmitting path.

26. The system of Claim 2, wherein the light source unit comprises diffractive or refractive optics accommodated in the optical path of light emitted by at least one LED and operating to provide high efficient coupling of

30

Lambertian light into a ring, thereby producing said at least one ring-like shaped light beam.

27. The system of any one of preceding Claims, wherein the light source unit comprises an adaptor unit carrying the LED arrangement and being configured
5 and operable for selectively shifting one or more of the LEDs into an operation mode.

28. The system of Claim 27, wherein said adaptor unit comprises: at least one first light unit formed by the first light guide unit carrying at its one end the first LED operating in a near infrared range and its other end carrying a first
10 condenser lens arrangement; and at least two second light units each formed by the second light guide unit carrying at its one end the second LED operating in a visible spectral range and carrying a second condenser lens arrangement; the second light unit being arranged along an axis intersecting with the first light unit thereby enabling to combine the first and second light paths; said at least two
15 second light units being mounted on a member rotating with respect to said first light unit.

29. The system of Claim 28, wherein said adaptor unit comprises a wavelength-selective arrangement accommodated at the intersection between the first and second optical paths.

20 30. The system of claim 29, wherein said wavelength-selective arrangement is configured to reflect visible light and transmit NIR light.

31. The system of any one of Claims 28 to 30, wherein said adaptor unit comprises the multiple second light units containing the LEDs emitting different wavelengths of the visible range.

25 32. The system of Claim 1, wherein the light source unit comprises at least one LED assembly, each LED assembly comprising multiple LEDs associated with the common light guide configured for coupling light from said multiple LEDs into a single ring-like light beam.

30 33. The system of Claim 32, wherein the LED arrangement comprises at least two LED assemblies, each LED assembly being formed by the multiple

LEDs coupled to the common light guide; the light directing optics comprising a wavelength-selective arrangement including at least one wavelength-selective filter for combining light from said at least two light assemblies.

34. The system of Claim 2, wherein the LED arrangement comprises at least one ring-like shaped member carrying the multiple LEDs of at least one LED assembly, thus creating a ring-like shaped light source formed by the LEDs arranged in a circular array.

35. The system of Claim 34, wherein the locally adjacent LEDs in the circular array differ from each other in at least one of emitting spectra and power.

36. The system of Claim 34, wherein the LEDs array contains different groups of LEDs, wherein the LEDs of each group are substantially identical in at least one of spectrum and power, different from that of the other group.

37. The system of any one of Claims 34 to 36, wherein the LED arrangement comprises at least two said LED assemblies; the light directing optics comprising a wavelength-selective arrangement including at least one wavelength-selective filter for combining light from said at least two light assemblies.

38. The system of any one of Claims 34 to 37, wherein at least some of the LEDs are associated with a condenser lens arrangement configured to narrow an emitting angle of light emitted by the LED.

39. The system of any one of Claims 34 to 37, wherein at least some of the LEDs are associated with a light diffusing element, thereby providing substantially uniform illumination of said illuminating light beam.

40. The system of any one of Claims 34 to 38, comprising at least one micro lens array configured to condense or diffuse light emitted by at least some of the LEDs in the circular array.

41. The system of Claim 1, wherein the light source unit comprises at least one integrating sphere that carries the multiple LEDs of at least one LED assembly of said LED arrangement and is formed with a ring-like window for the light output, the integrating sphere being configured to recycle light emitted by the LEDs by internal reflection in the integrating sphere.

42. The system of Claim 41, wherein an inner surface of said window has a reflective coating.
43. The system of Claim 41, wherein the light source unit comprises an external mask positioned so as to cover an inner diameter of the window.
- 5 44. The system of Claim 41, wherein the light source unit comprises a light-guide accommodated at said window and configured for narrowing light exit angles of the ring-shaped window to match those acceptable by an objective lens arrangement.
45. The system of any one of Claims 41 to 44, wherein said integrating
10 sphere contains light from multiple different wavelength channels.
46. The system of any one of Claims 41 to 44, wherein the LED arrangement comprises at least two said LED assemblies; the light directing optics comprising a wavelength-selective arrangement including at least one wavelength-selective filter for combining light from said at least two light assemblies.
- 15 47. The system of any one of preceding Claims, wherein the LED arrangement comprises at least two LED assemblies emitting light of, respectively, exciting and visible wavelength ranges; the system comprising at least one spectral filter accommodated in the optical path of the returned light.
48. The system of Claim 47, wherein the spectral filter is configured for
20 transmitting excited light, created in the eye region in response to said exciting light, and blocking the exciting light.
49. The system of claim 48, wherein the spectral filter is displaceable between its operating position being in the optical path of returned light and its inoperative position being outside of said optical path.
- 25 50. The system of Claim 47, wherein the spectral filter is configured as a dual spectrum barrier filter defining two spectral bandwidths corresponding to those used for, respectively, fluorescein (FA) and Indo-Cyanine Green (ICG) angiography, thereby enabling to obtain FA and ICG images by applying visible illumination and NIR flashes at least quasi-simultaneously.

- 51.** The system of Claim 50, wherein the image detector unit comprises a CMOS or CCD image detector sensitive to a 400-850nm spectral range.
- 52.** The system of any of preceding Claims, wherein the light source unit comprises one or more LEDs operating in a pulsed mode.
- 5 **53.** The system of Claim 52, wherein the pulsed mode light source unit operates with up to 30 or more frames per second.
- 54.** The system of Claim 52 or 53, wherein the light source unit comprises one or more LEDs operating in a continuous illumination mode.
- 55.** The system of Claim 54, comprising a control system connectable to the
10 light source unit and to the image detector unit, and configured for analyzing images acquired with the pulse and continuous modes to set appropriate light exposure parameters in either one of the application modes or both of them.
- 56.** The system of Claim 55, wherein the control system is configured and operable to analyze data indicative of the images acquired with the continuous
15 light mode to utilize this data for optimizing at least one of the light exposure parameters to be used in the pulsed mode imaging.
- 57.** The system of Claim 55, wherein said control system is configured for analyzing data indicative of the successively acquired pulse mode images to thereby improve pulse mode image total exposure and contrast.
- 20 **58.** The system of any one of Claims 55 to 57, wherein said control system is configured for analyzing data indicative of the images acquired with the continuous light mode to thereby improve continuous light mode images total exposure and contrast.
- 59.** A method for use in imaging the patient's retina, the method comprising
25 producing light of multiple different wavelengths emitted by a light emitting diode (LED) arrangement; passing the emitted light through a light guide arrangement configured for coupling light from the LEDs and providing one or output light beams of a desired shape; directing said output light towards a region of the retina and collecting light returned from the illuminated region through the

same objective lens arrangement; and imaging the collected returned light onto an image detector unit.

60. The method of Claim 59, controllably operating the LED arrangement to selectively shifting one or more LED assemblies of said LED arrangement into
5 an operational mode.

61. The method of Claim 59 or 60, comprising controllably operating the image detector unit to selectively detect the image of the retina image by a different image detector.

62. The method of any one of Claims 59 to 61, comprising operating at least
10 some of LEDs in a pulsed illumination mode.

63. The method of any one of Claims 59 to 62, comprising operating at least some of LEDs in a continuous illumination mode.

64. The method of Claim 62 or 63, wherein said operating of at least some LEDs in the pulsed illumination mode comprising pumping each of these LEDs
15 by one or more pulses of electric current while controlling the electric current value, so as to provide maximal emitted energy of the LED, thereby providing fast and effective pulsed mode operation.

65. The method of any one of Claims 59 to 64, comprising concurrent or quasi-concurrently operating the different wavelengths LEDs to produce FA and
20 ICG exciting illumination.

66. The method of any one of Claims 59 to 65, wherein said directing of the LEDs output light towards the region on the retina comprising combining a first optical path of the NIR LED light with a second optical path of the visible LED light.

67. The method of Claim 66, comprising selectively bringing the different visible LED to said second optical path.

68. The method of any one of Claims 59 to 67, comprising operating the LED arrangement in an FA mode by generating light of a Cyan color, thereby providing optimal excitation of fluorescein.

69. The method of Claim 68, wherein said Cyan color is of a 485nm–500nm wavelength range.

70. The method of any one of Claims 62 to 69, comprising controlling the LED arrangement operation by providing predetermined exposure settings for the pulsed light illumination and the continuous light illumination, providing data indicative of images acquired with the pulsed and continuous illumination modes, analyzing said data based on said predetermined exposure settings, and determining a new exposure settings to the pulsed light control and the continuous light control, thereby enabling to utilize the continuous light measured data to predict amount of light exposure to be used in the pulsed light illumination.

71. A light source unit for use in an imaging system, the light source unit comprising at least one assembly comprising multiple light emitting diodes (LEDs) arranged for producing a ring-like shaped light beam, each LED being coupled to one end of its dedicated optical fiber or fiber bundle, the other ends of the fibers or fiber bundles being attached to and arranged along a ring-like member, the light source unit thus allowing to use a central hole of the ring-like member as an imaging channel for passing therethrough light returned from an illuminated region.

72. The light source unit of Claim 71, wherein the LED is coupled to said one end of its dedicated fiber or fiber bundle via a lens arrangement.

73. The light source unit of Claim 71 or 72, comprising at least two said LED assemblies each associated with its ring-like member; and a wavelength-selective combiner arrangement for combining the ring-shaped light produced by the LED assemblies into a common optical path.

74. The light source unit of Claim 73, wherein said ring-like members are arranged on a rotatable member, rotation of said member allowing to selectively shift one of the ring-like members into an operation mode.

75. A light source unit for use in an imaging system, the light source unit comprising at least two LED based assemblies emitting light of different

- 48 -

wavelength ranges; a wavelength-selective combiner arrangement comprising at least one wavelength-selective combiner accommodated in optical paths of illuminating light portions produced by said at least two LED based assemblies, respectively, for combining said light portions into a single illuminating light path; and a mask configured to selectively define a different pattern in said combined optical path to affect the light impinging thereon to produce therefrom a desired ring-like shaped light beam.

76. The light source unit of Claim 75, comprising at least one wavelength selective filter unit accommodated in the optical path of light emerging from the at least one LED assembly.

77. A light source unit for use in an imaging system, the light source unit comprising a support assembly configured for supporting at least one first LED based unit emitting light of a first wavelength range; at least two second LED based units emitting light of at least two different second wavelength ranges; the LED based unit comprising one or more LED associated with a dedicated light guide configured to produce from light emitted by the respective LED a desirably shaped light beam; the second light guide extending along an axis intersecting with an axis defined by the first light guide thereby allowing to combine optical paths of the light beams generated by the first and second LEDs, the second light guides being mounted on a member rotatable with respect to the first light guide, thereby enabling to selectively locate a selected one of the second LED units in an operative position to combine optical paths of light emerging from the first light guide and light emerging from the selected second light guide.

78. An imaging system for use in imaging the patient's retina, the system comprising: (a) a first camera operable with pulse mode illumination; (b) a second camera operable with continuous mode illumination; and (c) a control system connectable to the first and second cameras and configured for controlling the operation thereof by analyzing either pulse mode or continuous images or both of them and utilizing reference data indicative of the images

corresponding to certain exposure parameters and determining optimal exposure parameters for either the pulse of continuous illumination or both of them.

79. The system of Claim 78, wherein the control unit is configured for analyzing said continuous illumination image data based on said certain exposure parameters, and determining a new exposure parameters to the pulsed light control and the continuous light control, thereby enabling to utilize the continuous light measured data to predict amount of light exposure to be used in the pulsed light illumination.

80. An imaging system for use in imaging the patient's retina, the system comprising: a first LED-based light source assembly for producing exciting light for an FA mode, and a second LED-based light source assembly configured for producing exciting light for an ICG mode, and a control system configured for operating the first and second light source assemblies to provide concurrent or quasi-concurrent acquisition of the FA and ICG images of the retina.

81. The system of Claim 80, wherein at least one of the first and second LED-based assemblies operates in a pulsed mode.

82. The system of Claim 81, comprising a control unit configured to pump said pulsed mode LED assembly by one or more pulses of electric current while controlling the electric current value, so as to provide maximal emitted energy of the LED, thereby providing fast and effective pulsed mode operation.

83. The system of any one of Claims 80 to 82, comprising a spectral barrier filter configured to select from light impinging thereon either one of the FA and ICG exciting spectral ranges, the filter being mounted so as to be shifted towards and away from an optical path of light propagation.

84. The system of any one of Claims 80 to 82, comprising a dual spectral barrier filter configured for selecting from light impinging thereon spectral ranges of the FA and ICG exciting light.

85. A method for controlling the operation of a fundus camera, the method comprising: providing predetermined exposure settings for flash light illumination and continuous light illumination; providing data indicative of

- 50 -

images acquired by a still image camera and a continuous mode camera;
analyzing said data based on said predetermined exposure settings, and
determining a new exposure settings to the flash light control and the continuous
light control, thereby enabling to utilize the continuous light measured data to
5 predict amount of light exposure to be used in the flash light illumination.

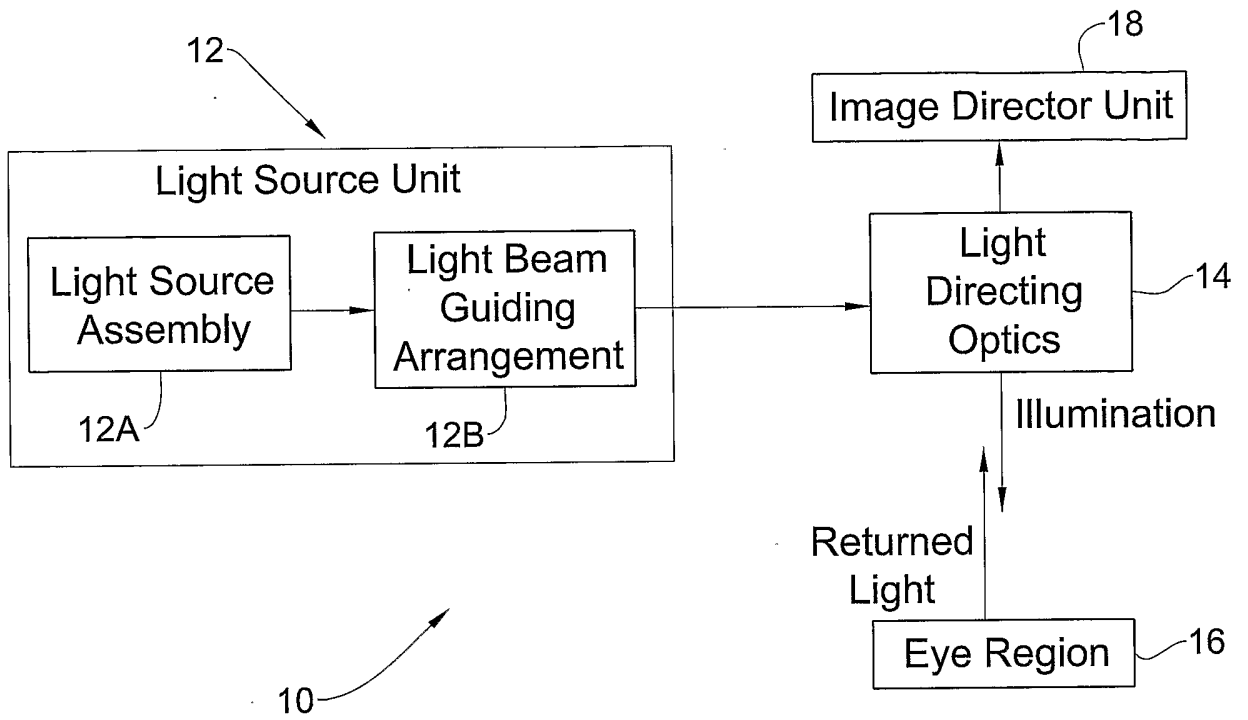

FIG. 1A

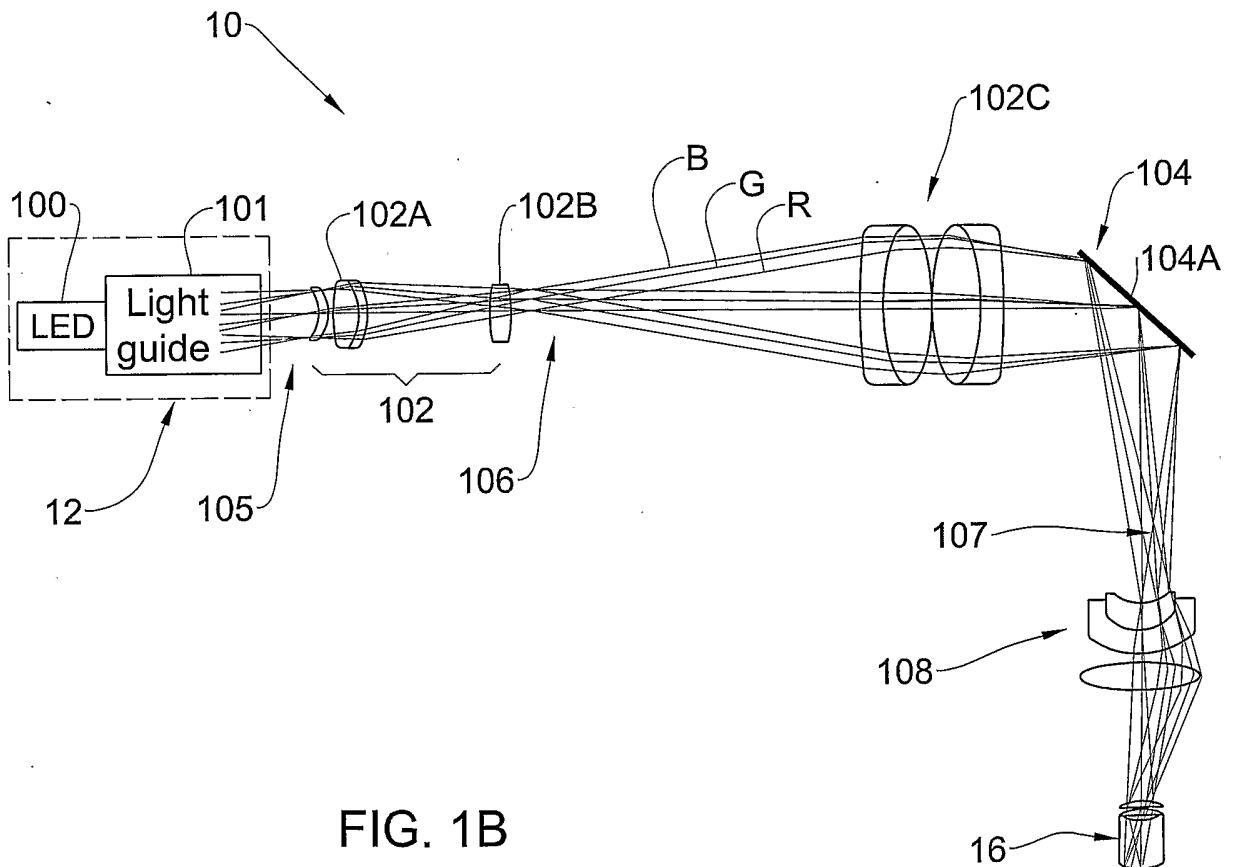

FIG. 1B

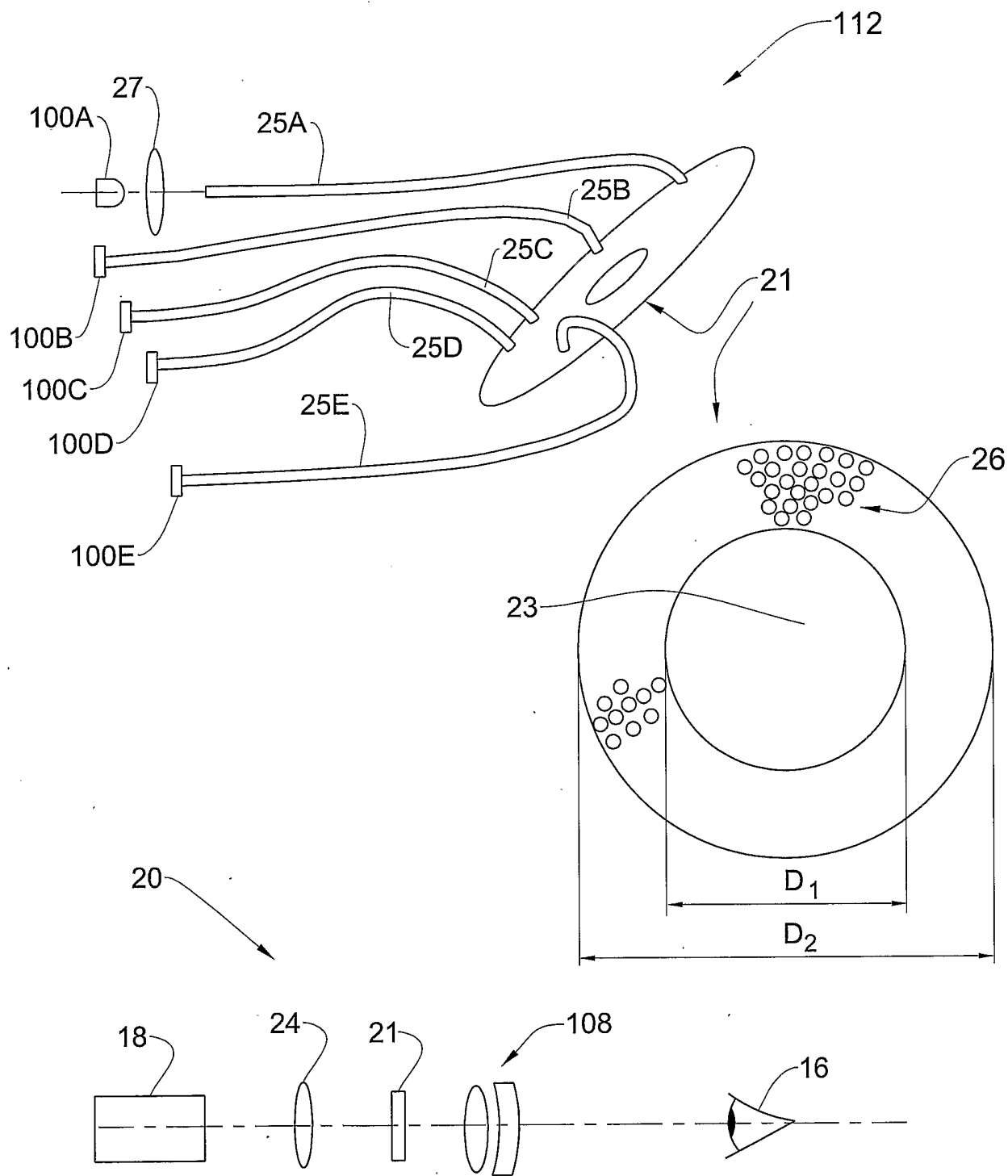

FIG. 2

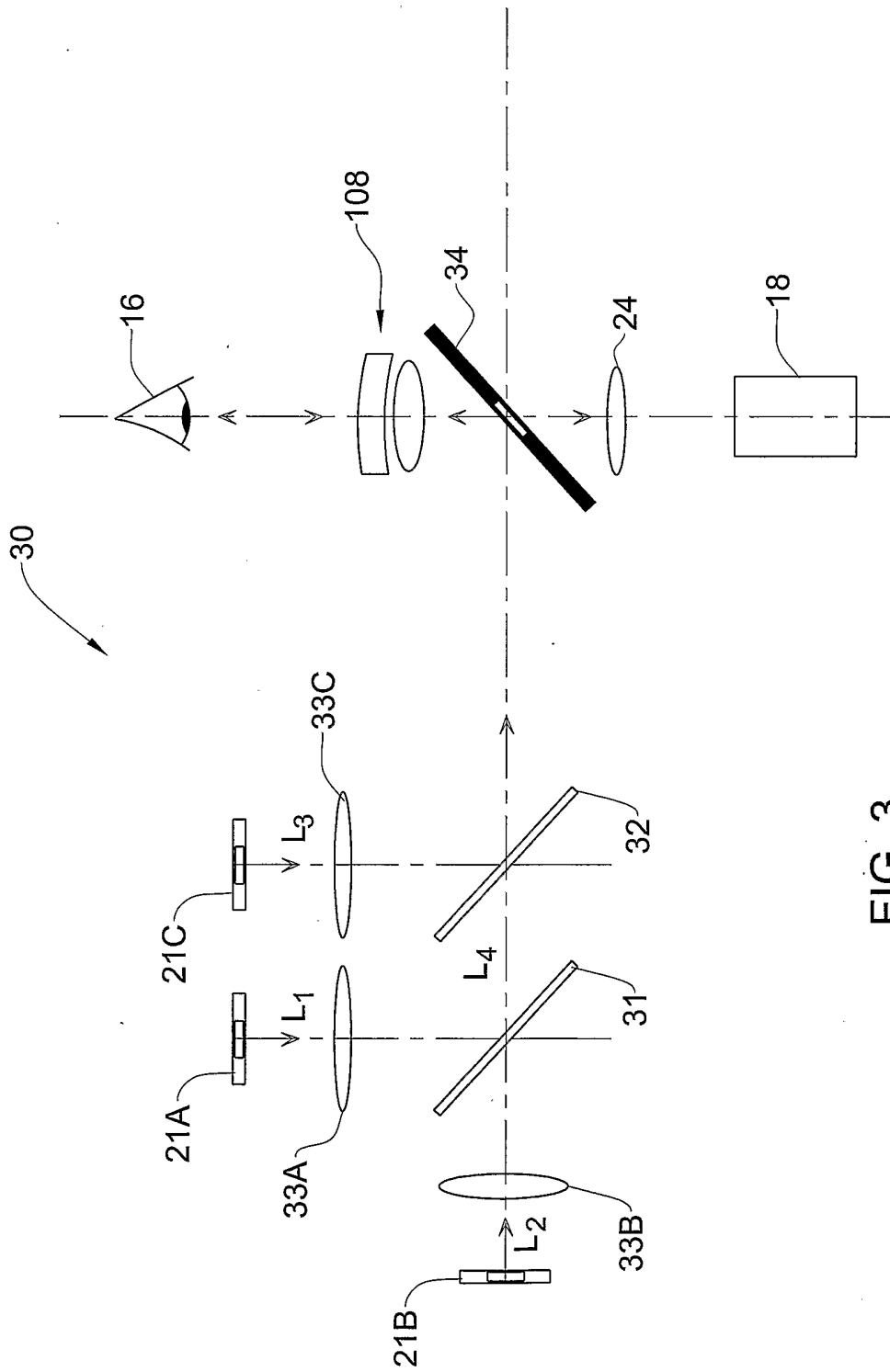

FIG. 3

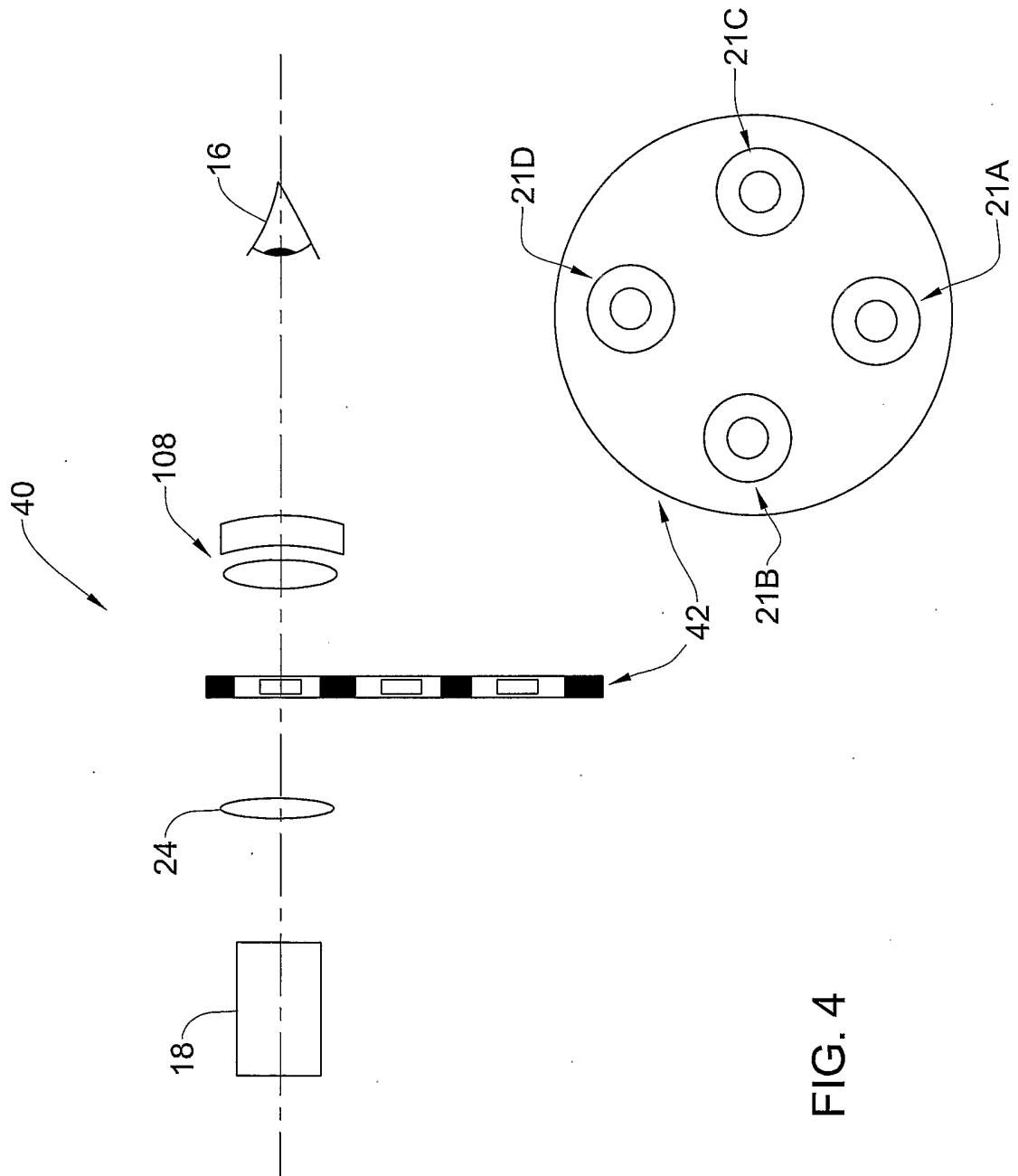

FIG. 4

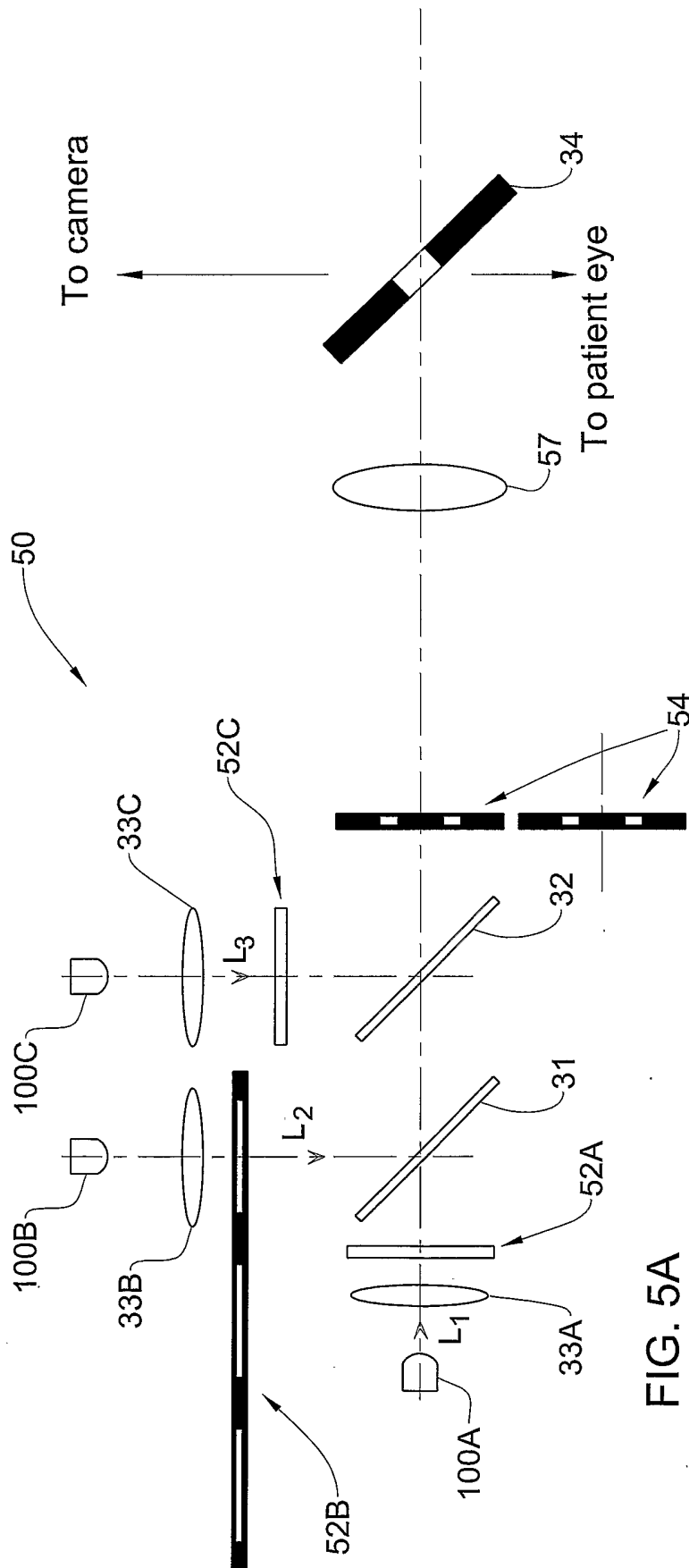

FIG. 5A

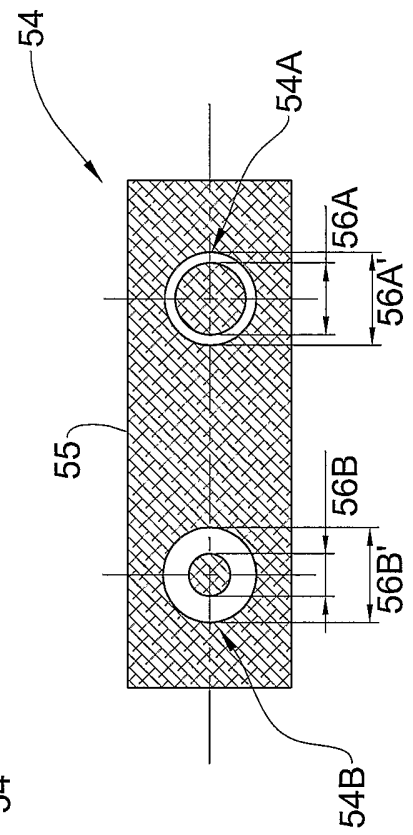

FIG. 5B

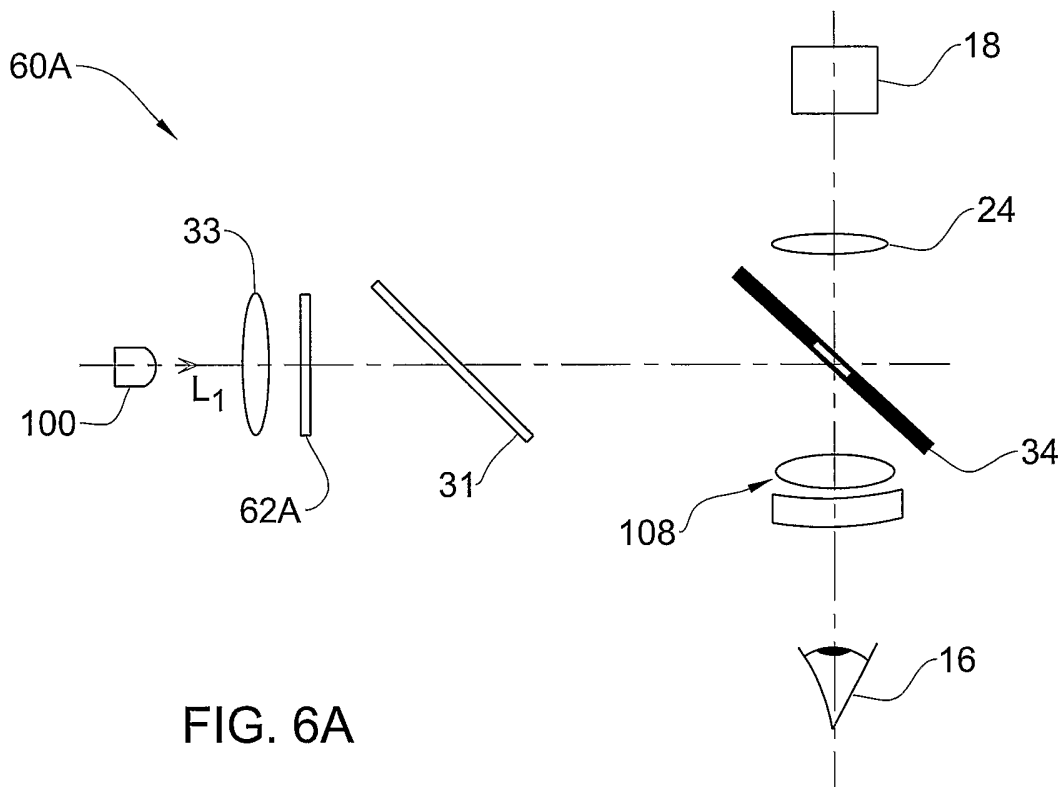

FIG. 6A

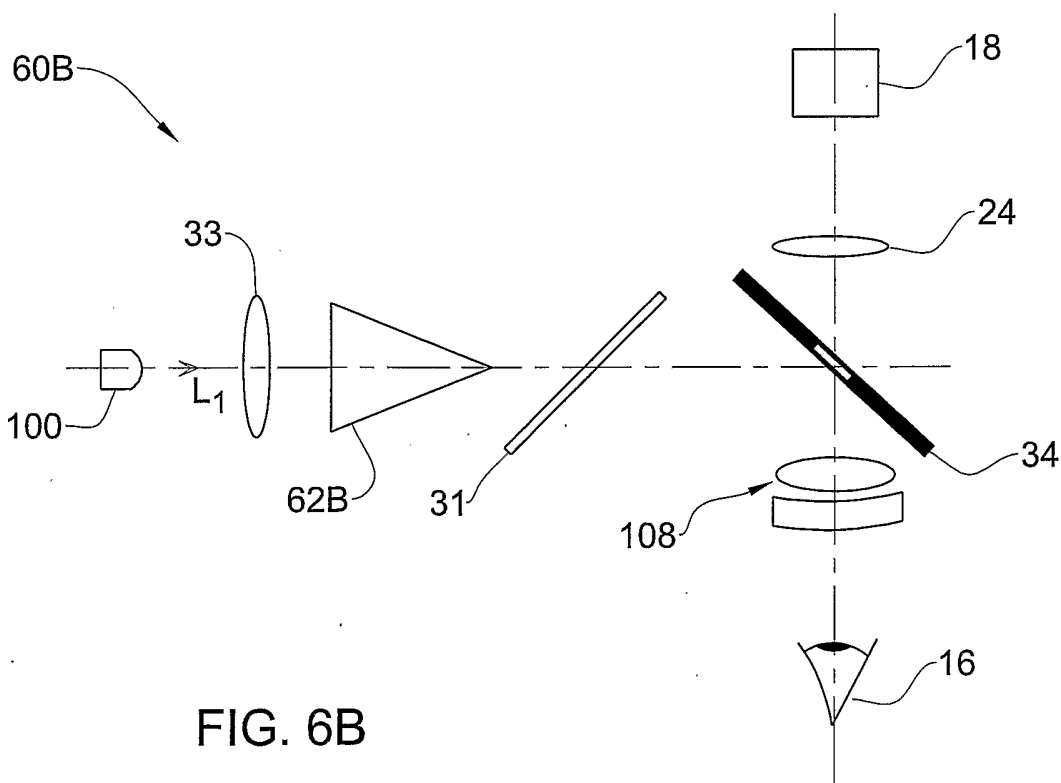

FIG. 6B

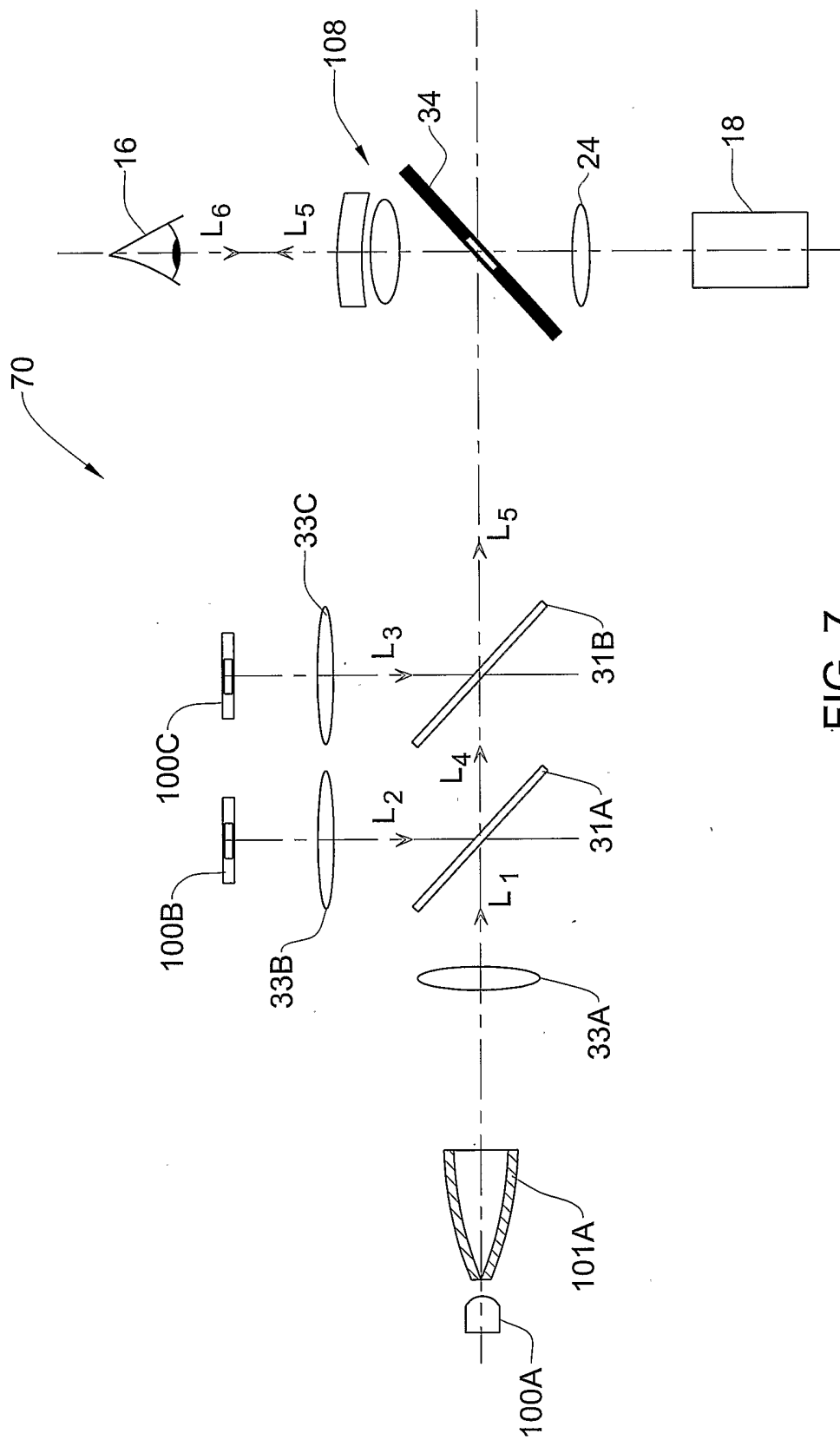

FIG. 7

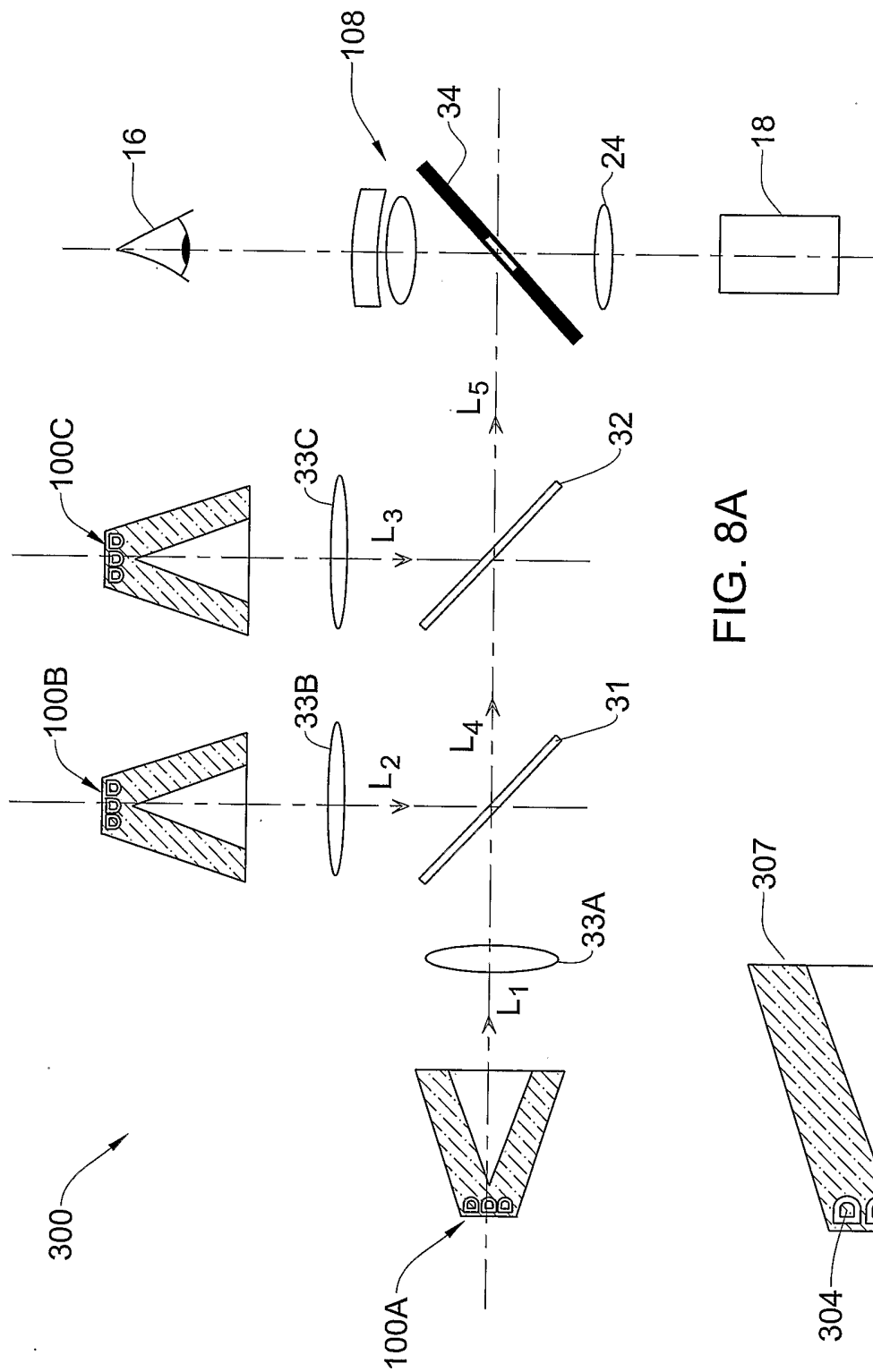

FIG. 8A

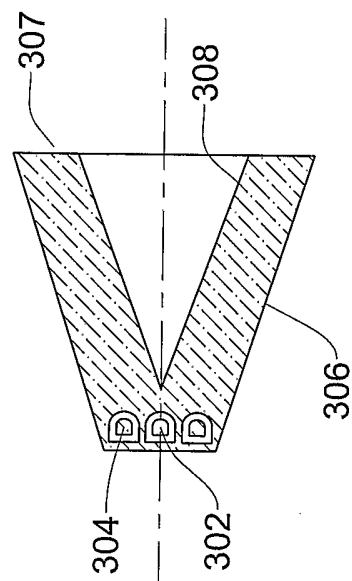

FIG. 8B

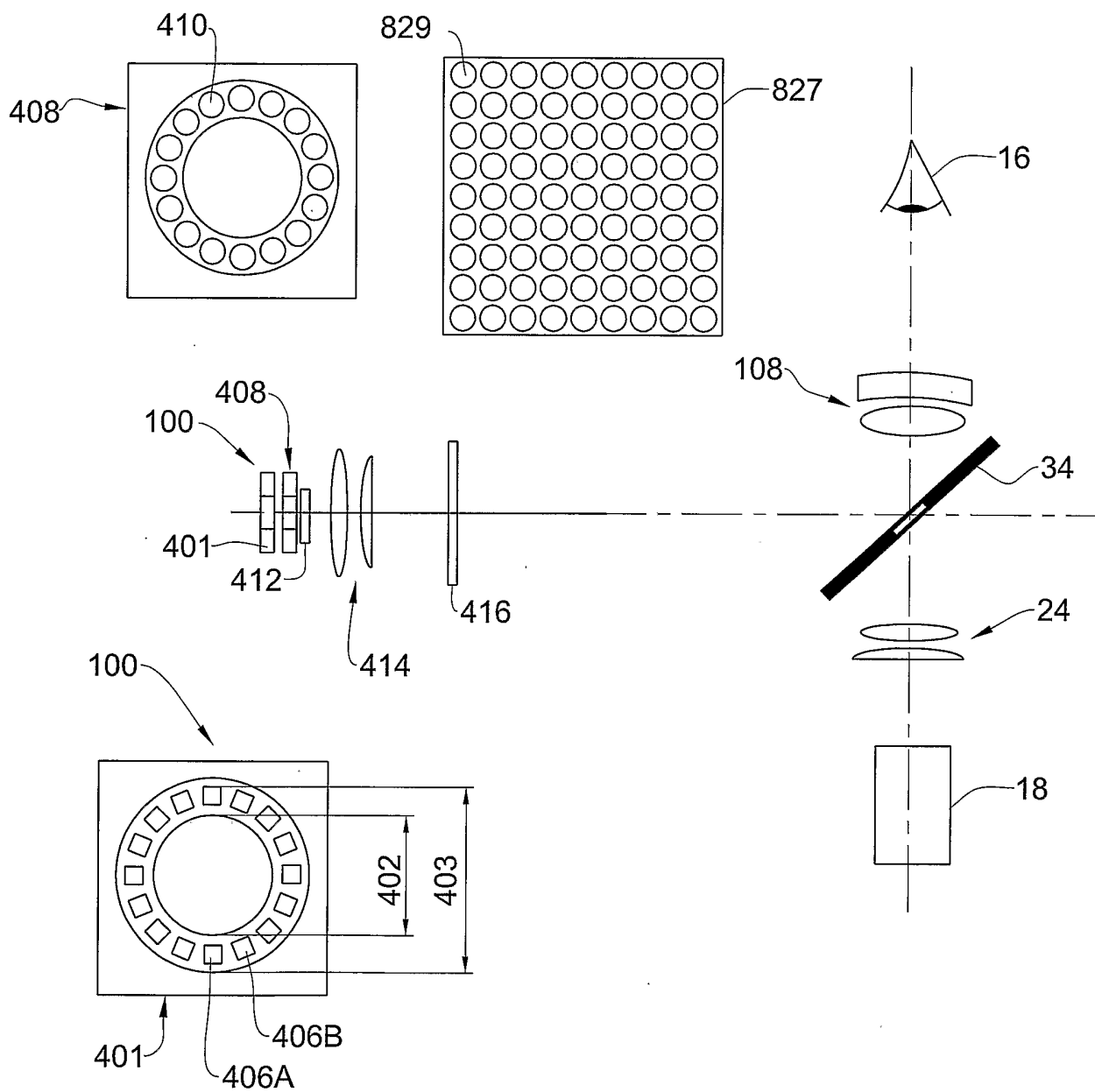

FIG. 9

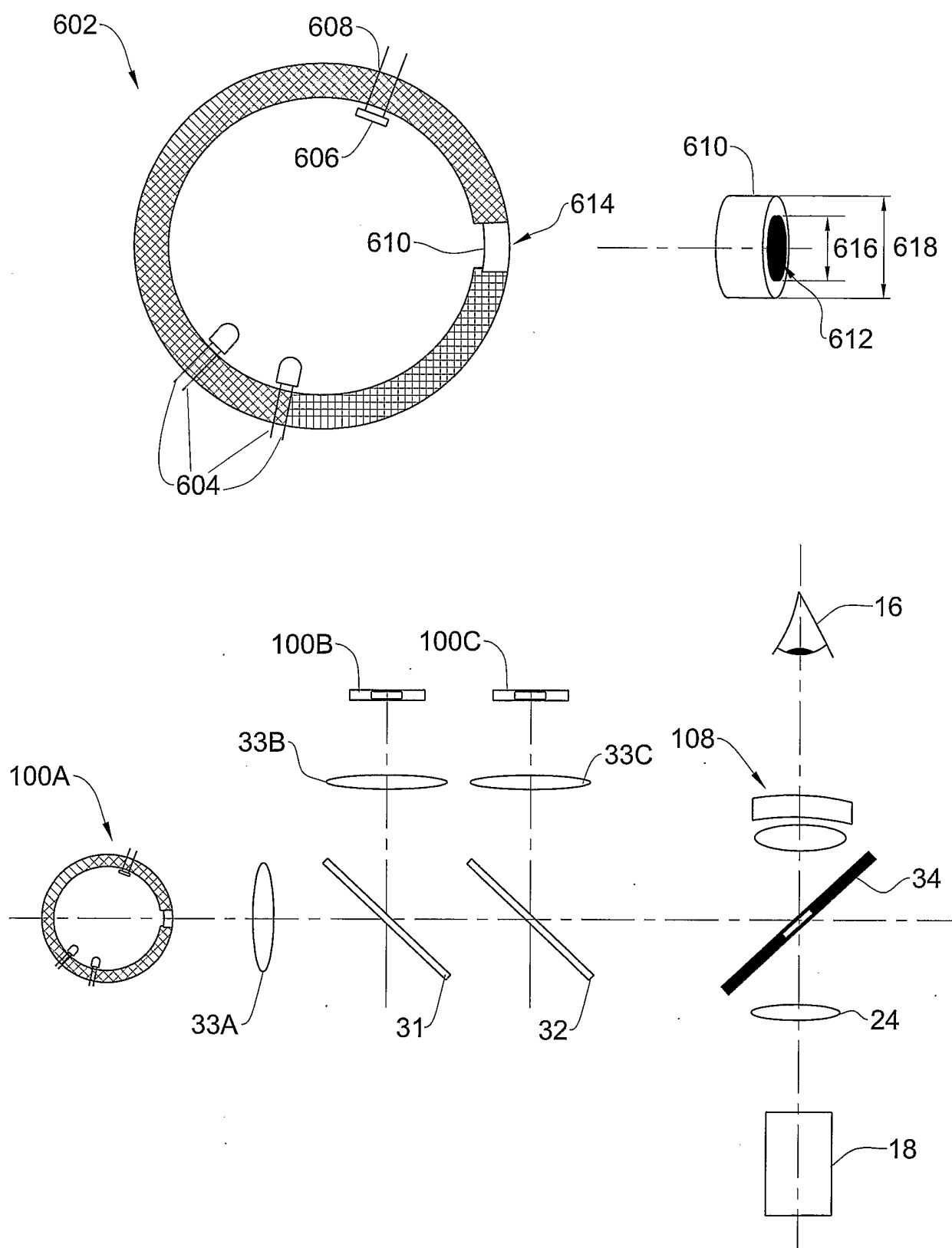

FIG. 10

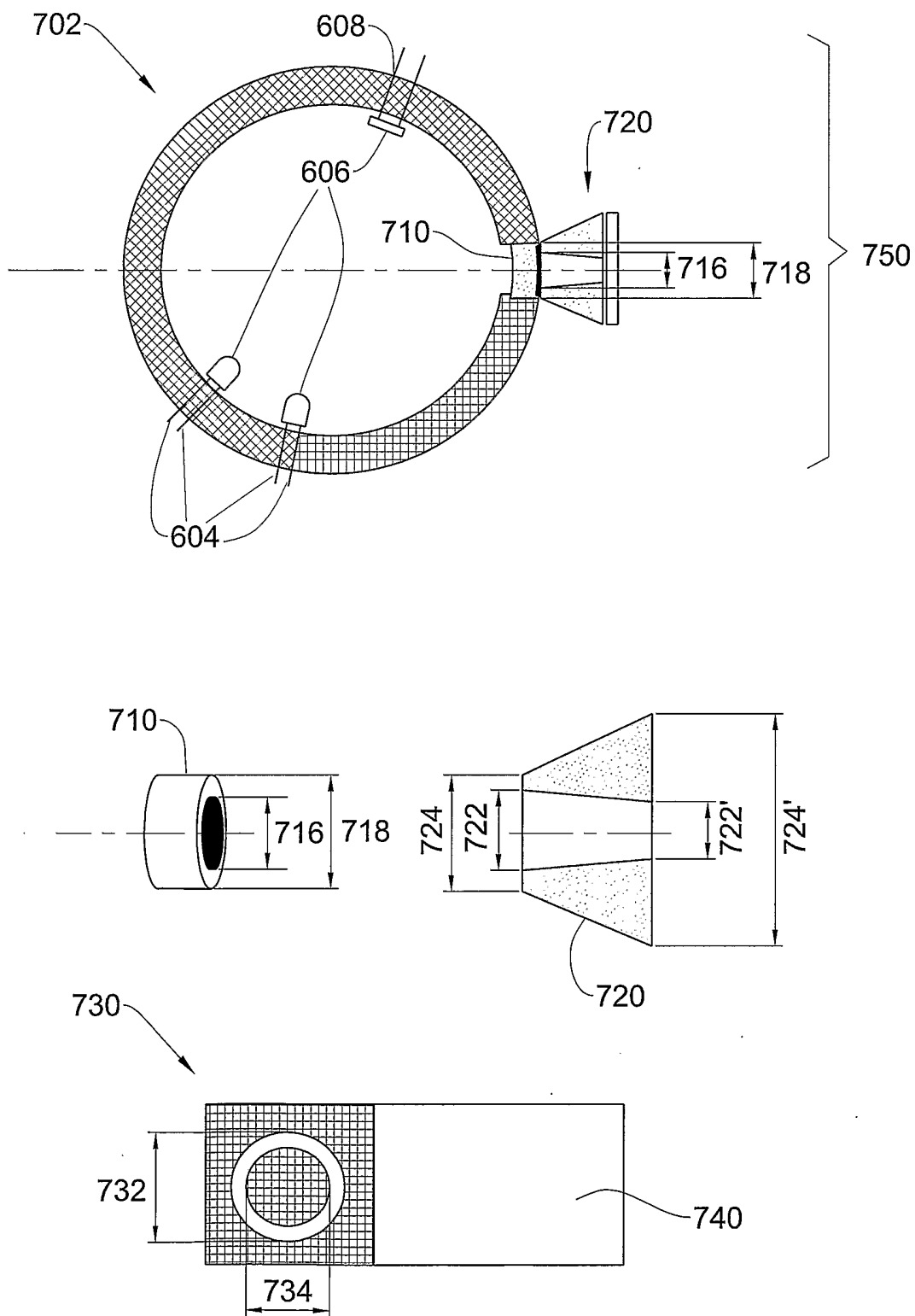

FIG. 11

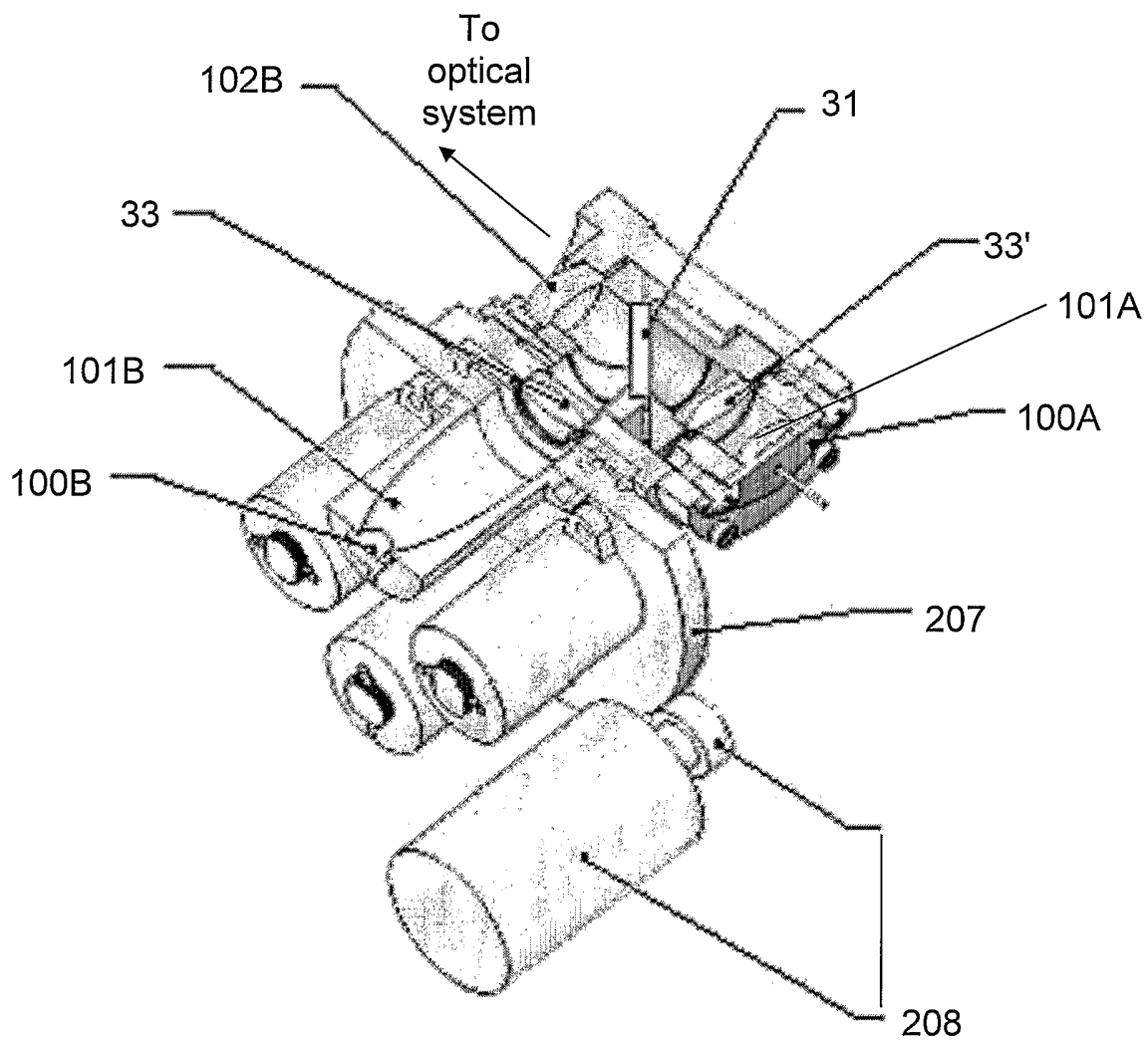

FIG. 12A

13/18

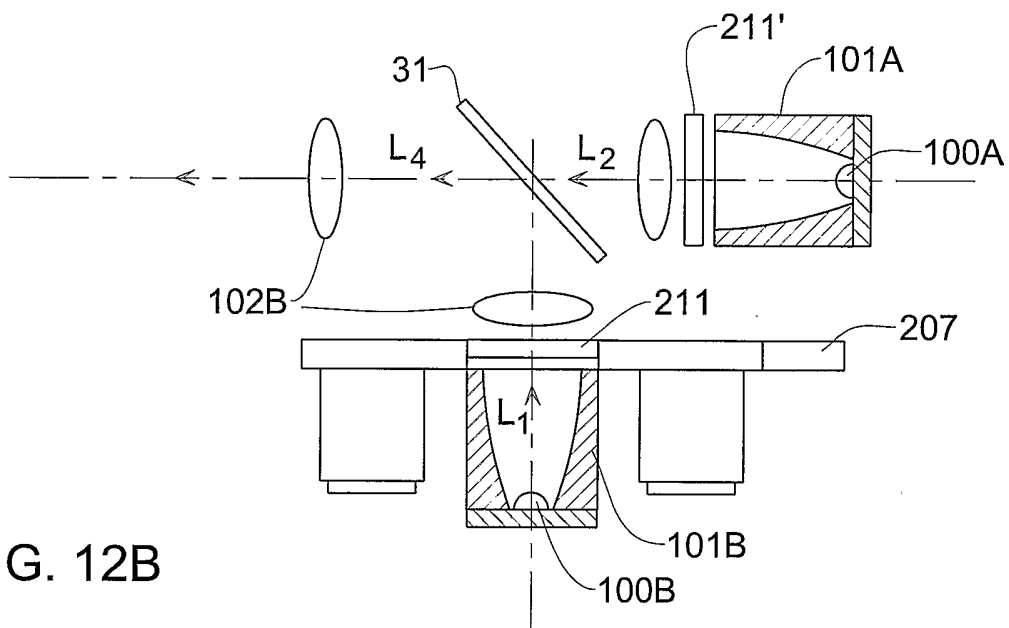

FIG. 12B

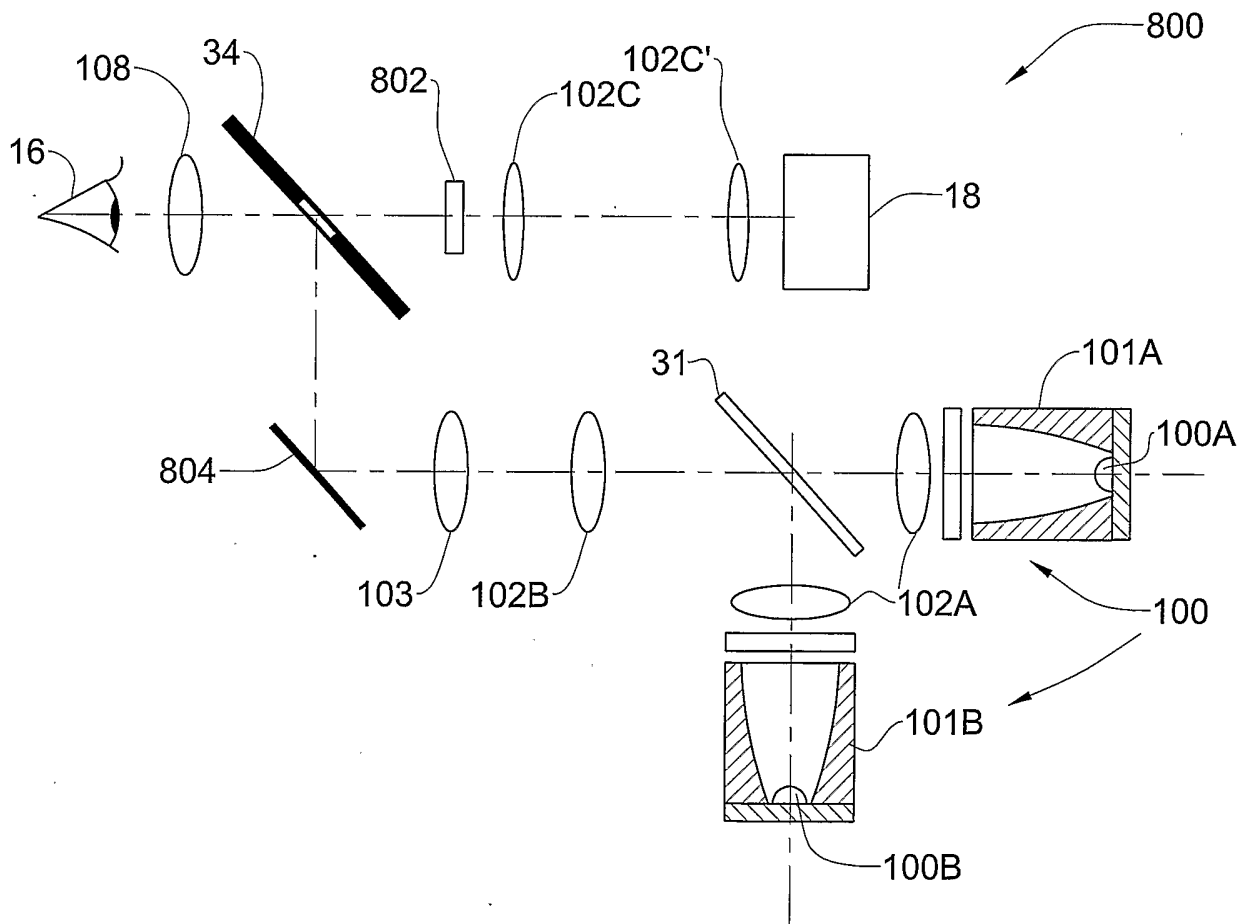

FIG. 13

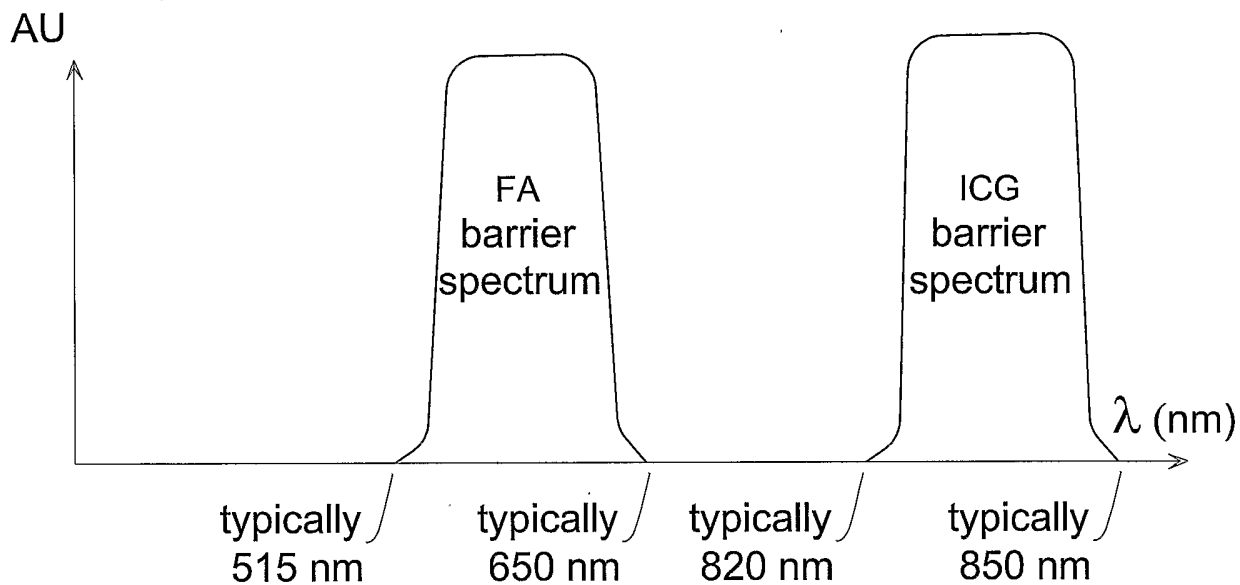

FIG. 14A

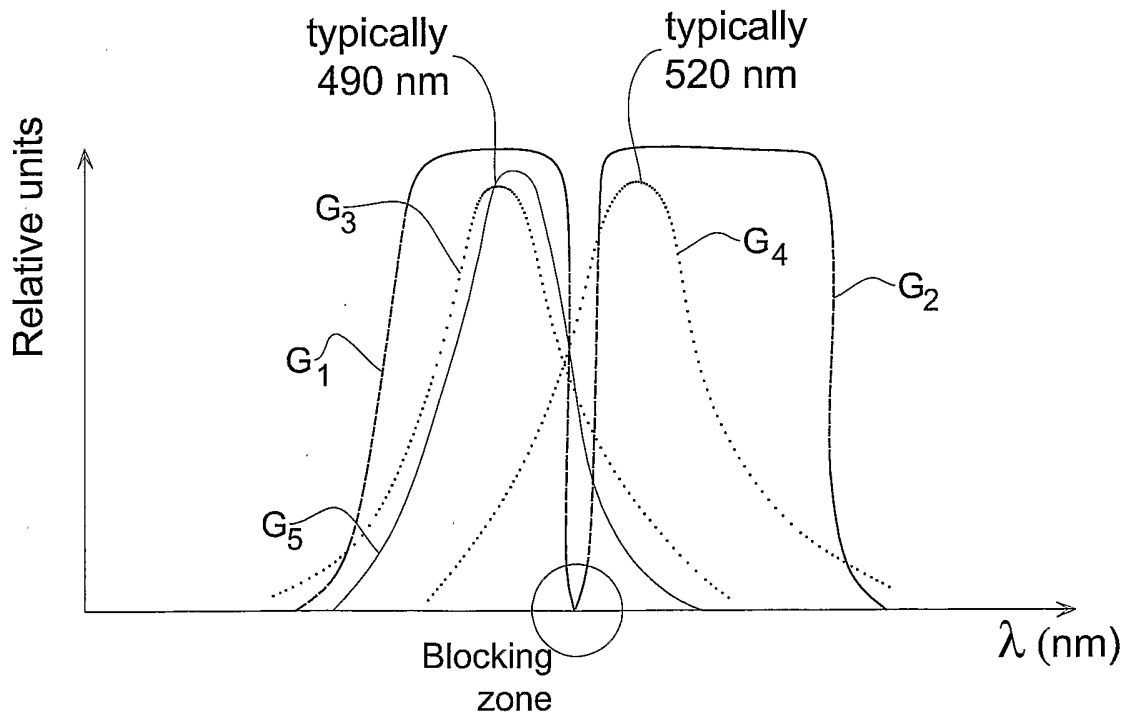

FIG. 14B

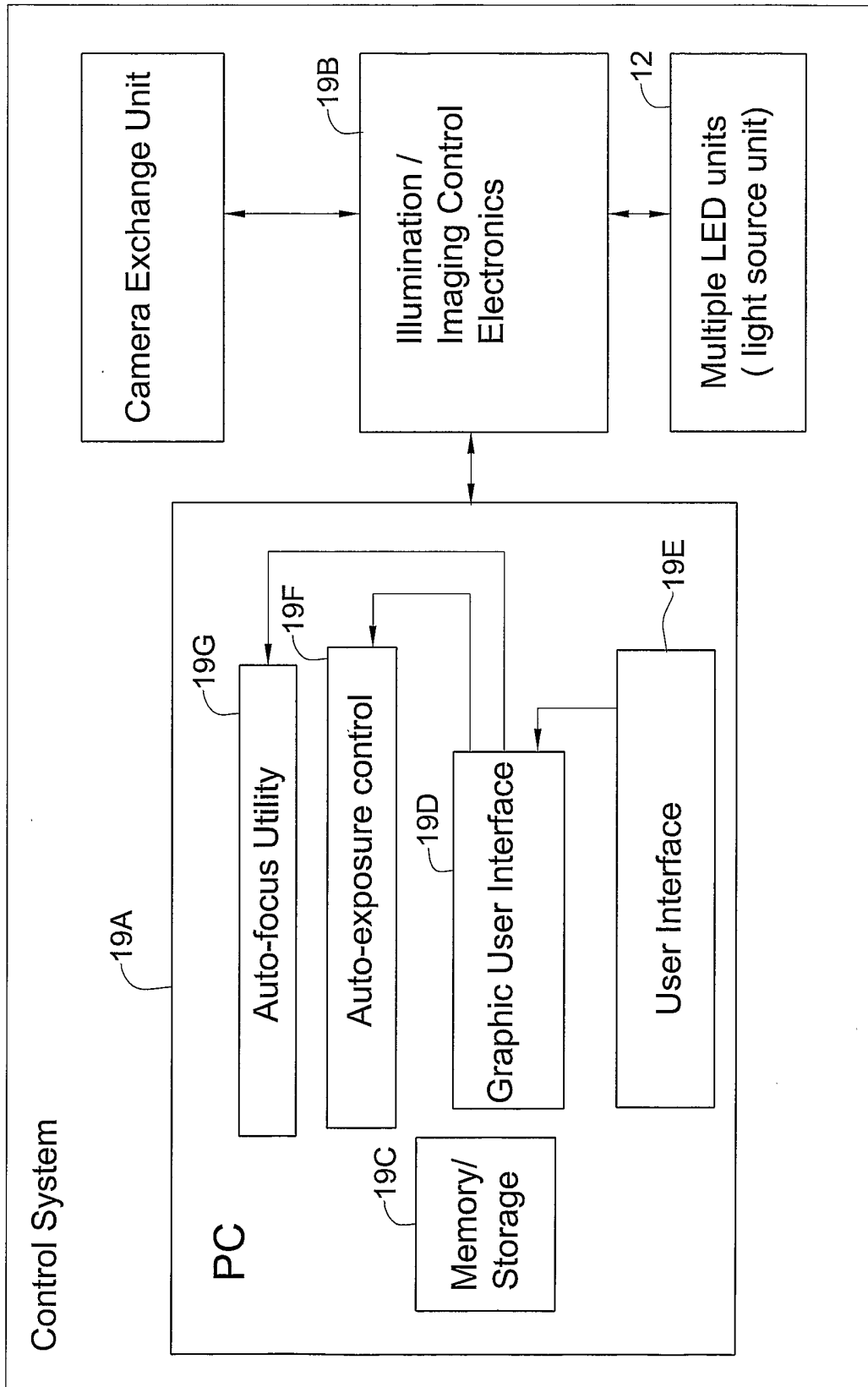

FIG. 15

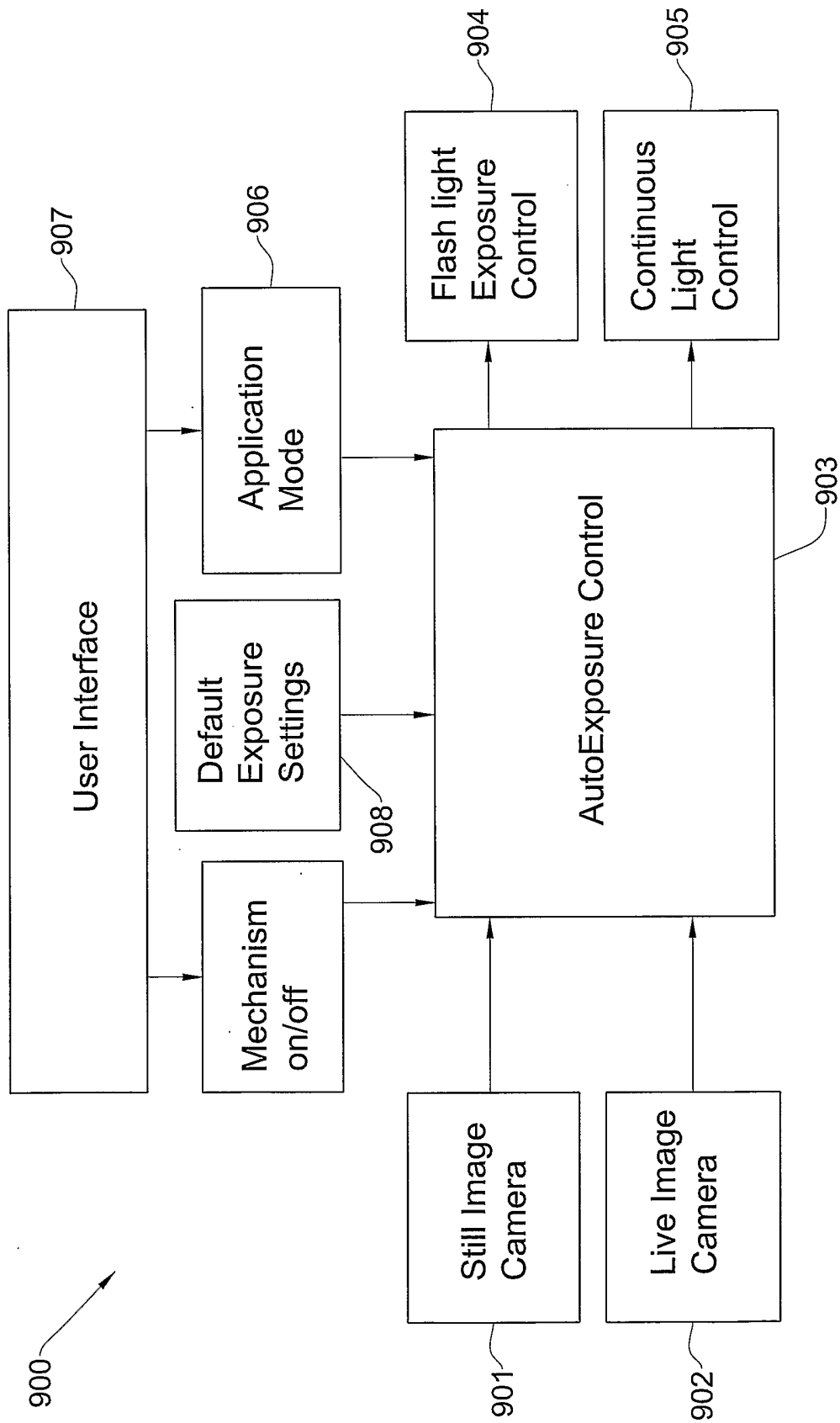

FIG. 16

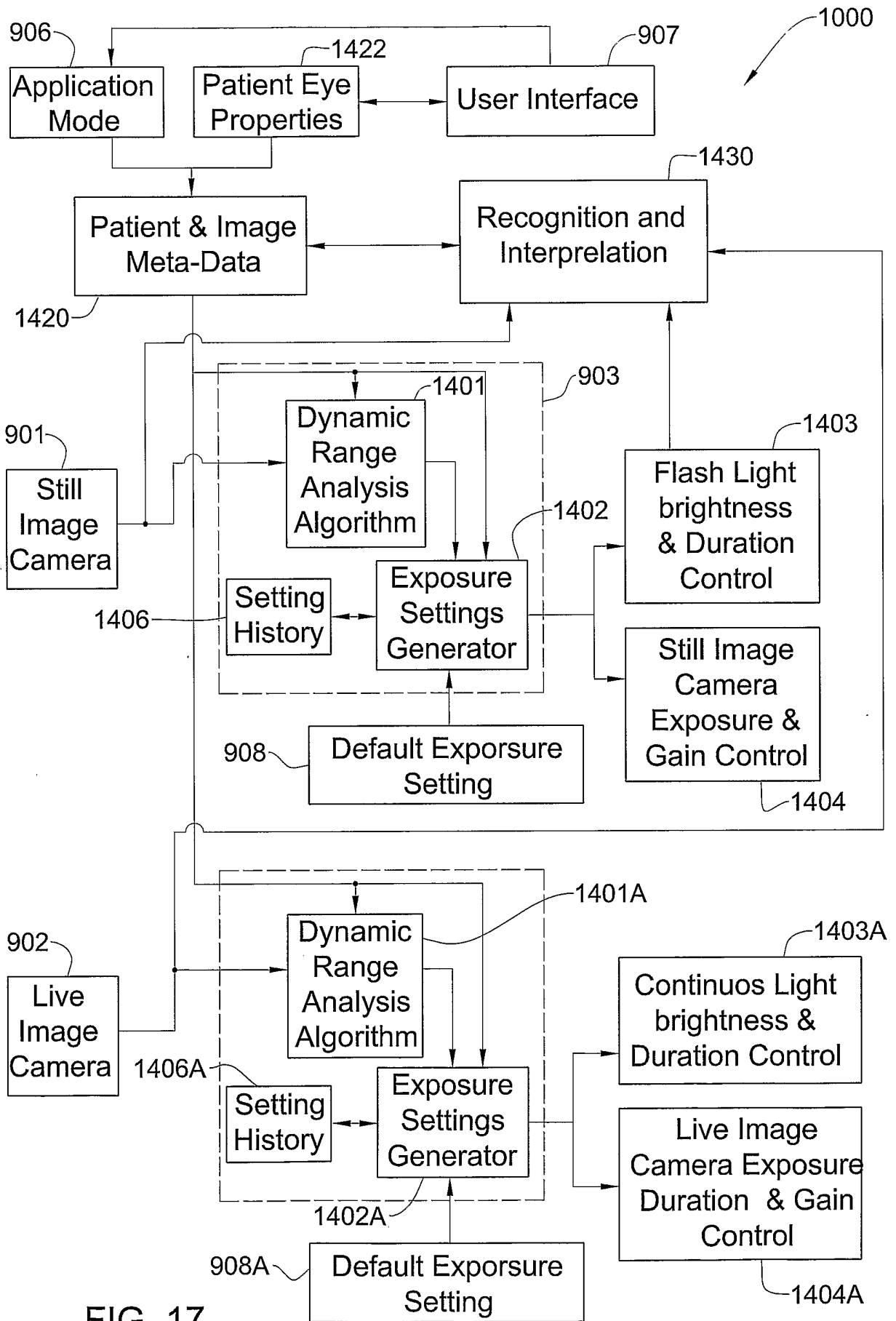

FIG. 17

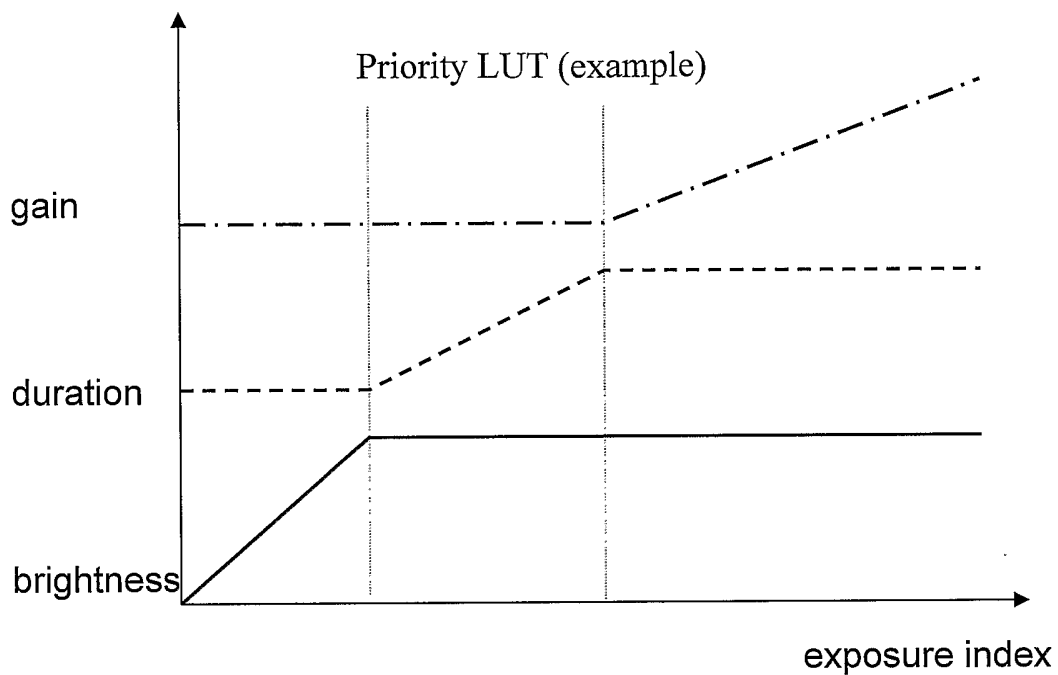

FIG. 18A

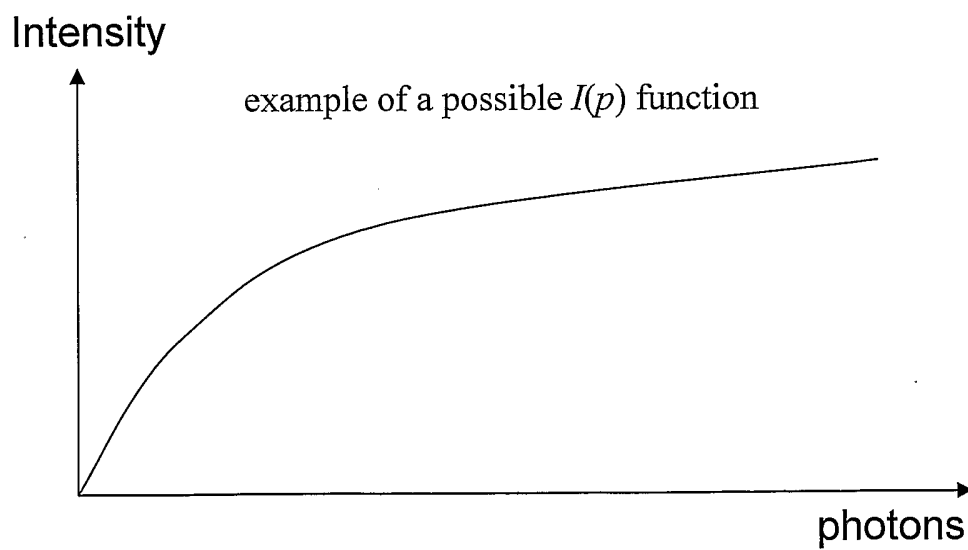

FIG. 18B