



US 20080306340A1

(19) **United States**

(12) **Patent Application Publication**
UCHIYAMA et al.

(10) **Pub. No.: US 2008/0306340 A1**

(43) **Pub. Date: Dec. 11, 2008**

(54) **ENCAPSULATED MEDICAL DEVICE GUIDANCE SYSTEM, AND METHOD OF CONTROLLING THE SAME**

Related U.S. Application Data

(63) Continuation of application No. PCT/JP2006/326146, filed on Dec. 27, 2006.

(75) Inventors: **Akio UCHIYAMA**, Yokohama-shi (JP); **Atsushi KIMURA**, Akiruno-shi (JP); **Isao AOKI**, Sagami-hara-shi (JP)

(30) **Foreign Application Priority Data**

Dec. 27, 2005 (JP) 2005-376277

Correspondence Address:
SCULLY SCOTT MURPHY & PRESSER, PC
400 GARDEN CITY PLAZA, SUITE 300
GARDEN CITY, NY 11530 (US)

Publication Classification

(51) **Int. Cl.**
A61B 1/00 (2006.01)

(52) **U.S. Cl.** **600/117; 600/118**

(57) **ABSTRACT**

An encapsulated medical device guidance system, and a method of controlling the system, in which guidance coils are arranged to divide a magnetic field generating plane into at least two front and rear areas, a magnetic field for canceling gravity applied to a capsule endoscope itself is formed, and superposed on a magnetic field for moving or changing an attitude, a frictional resistance in moving a capsule endoscope is reduced by decreasing an area of an endoscope to contact the surface of an intracavitary.

(73) Assignees: **OLYMPUS MEDICAL SYSTEMS CORP.**, Tokyo (JP); **OLYMPUS CORPORATION**, Tokyo (JP)

(21) Appl. No.: **12/147,262**

(22) Filed: **Jun. 26, 2008**

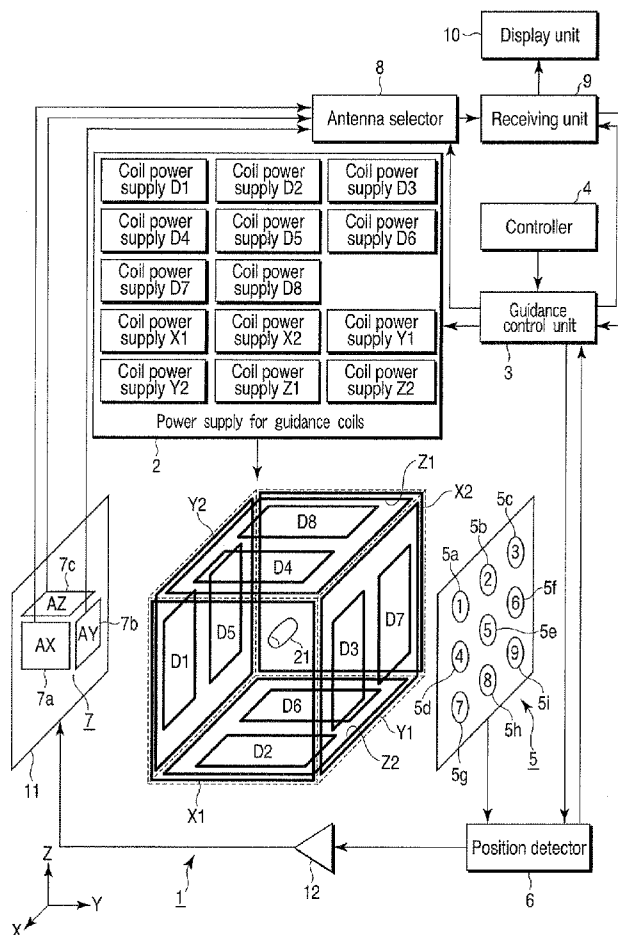

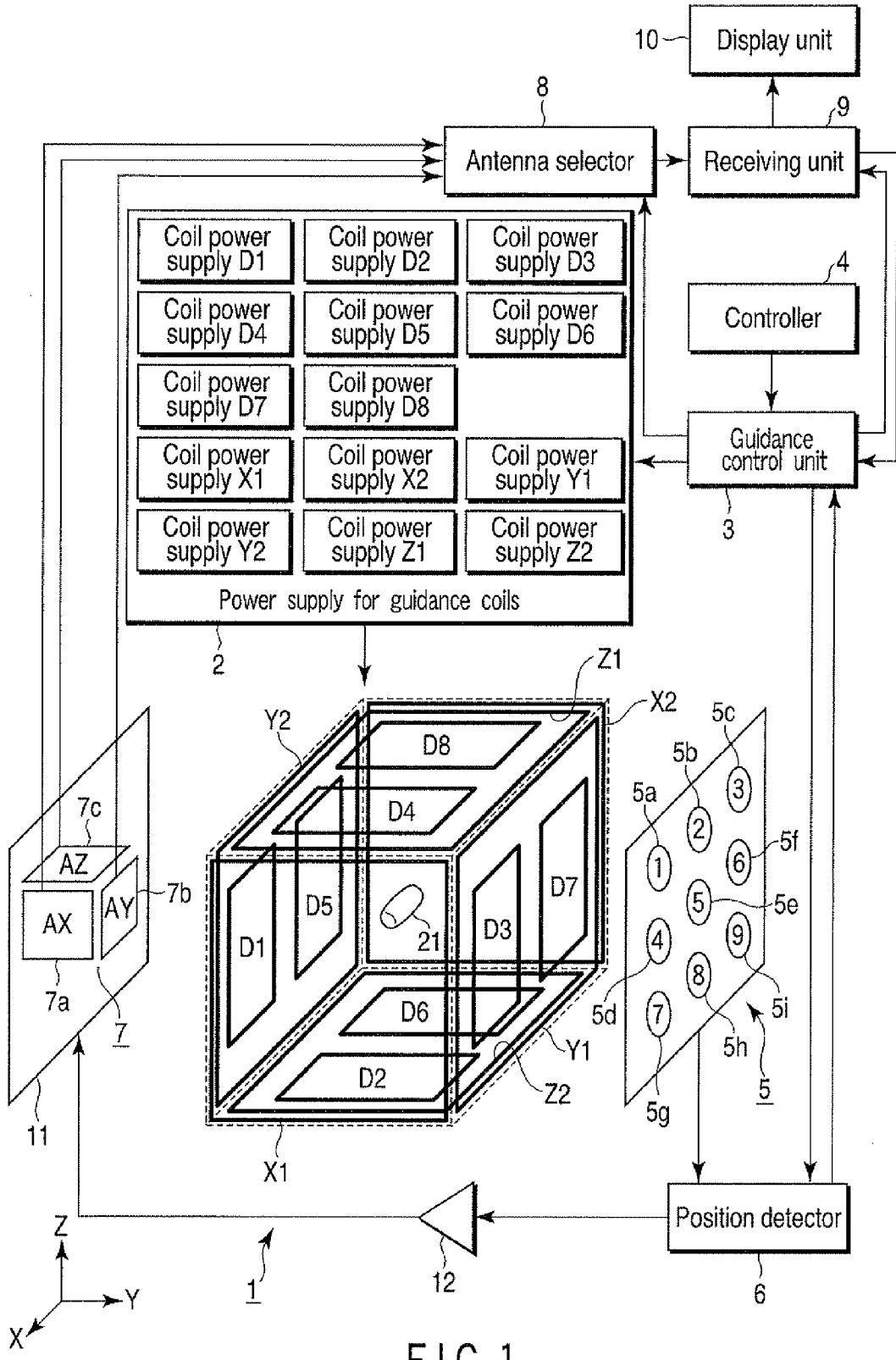

FIG. 1

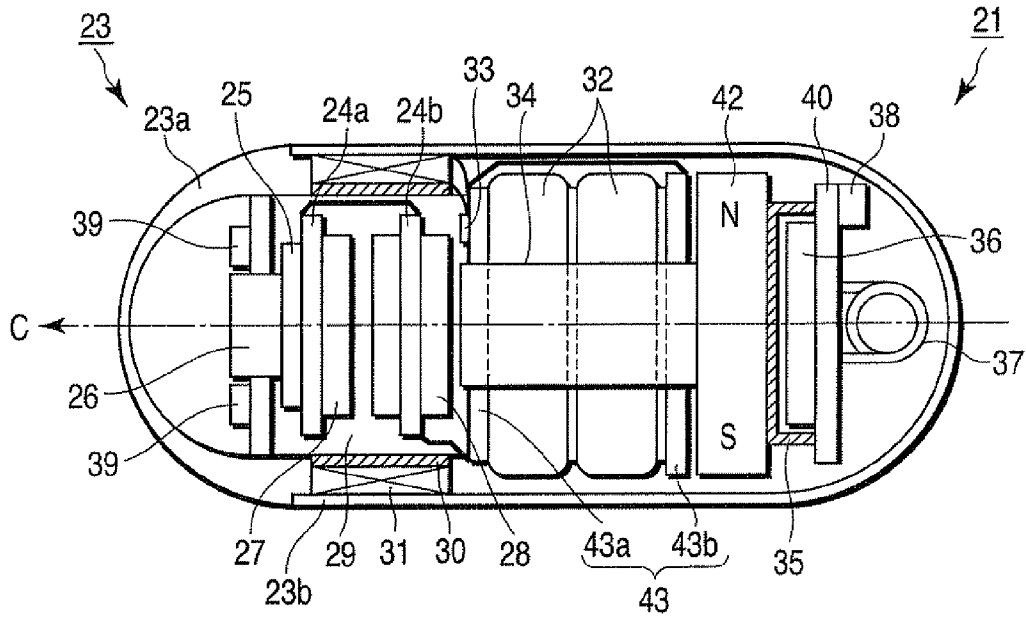

FIG. 2

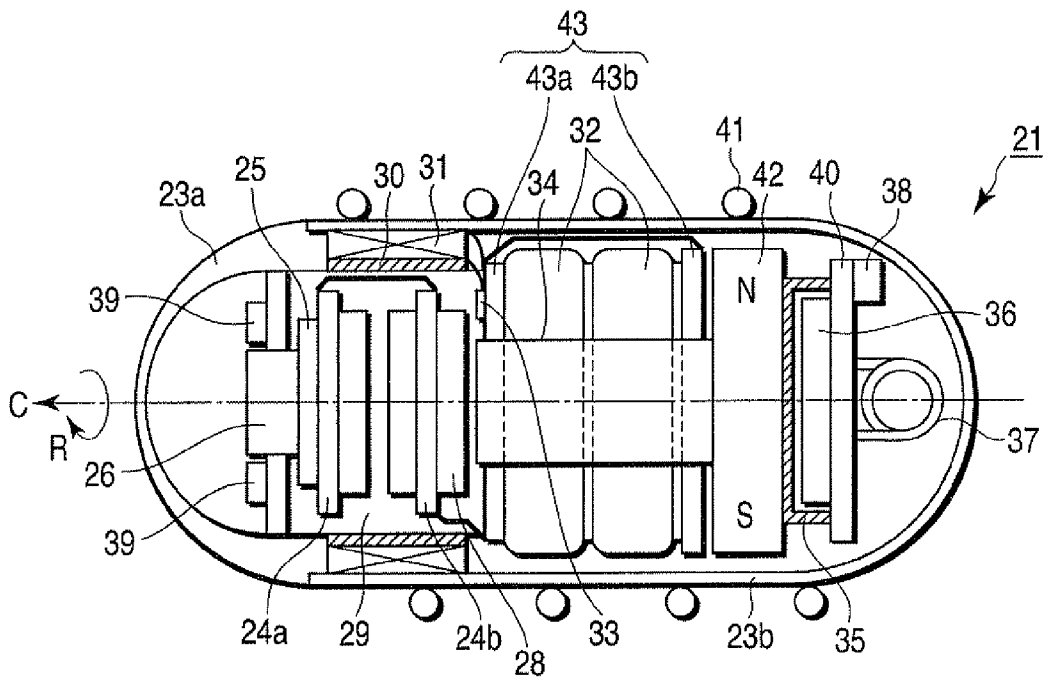

FIG. 3

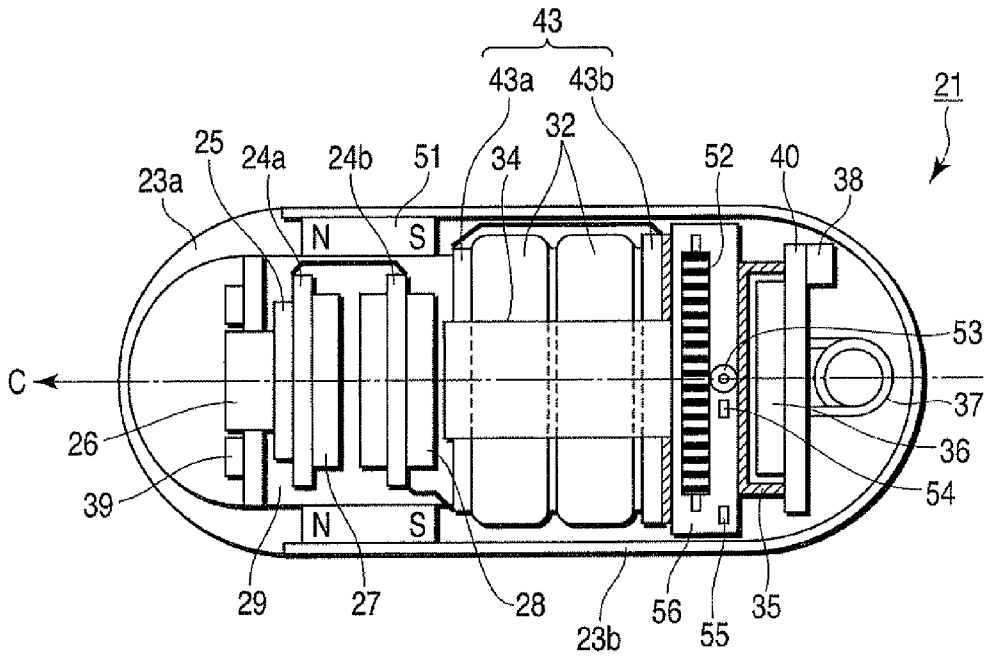

FIG. 4

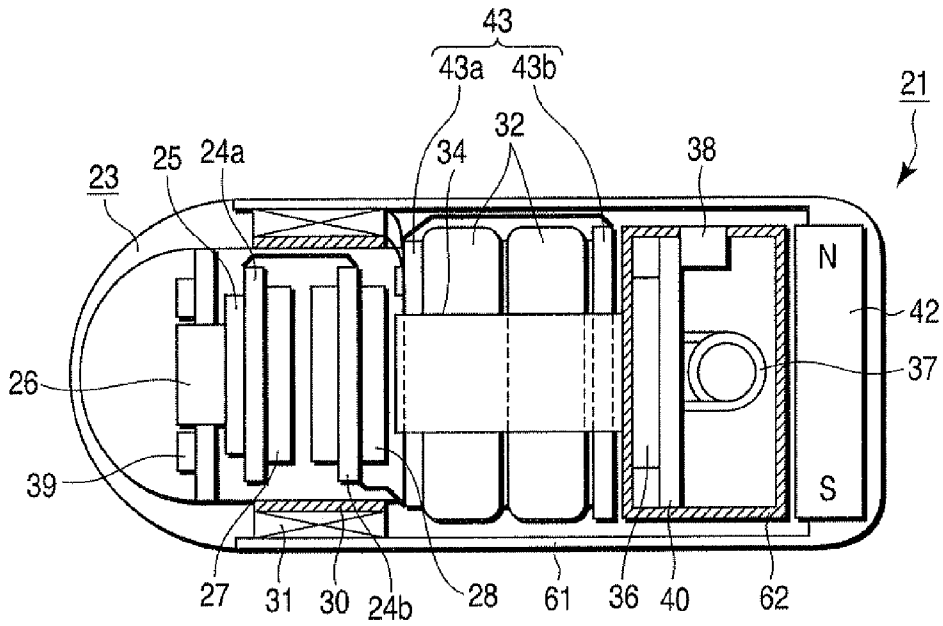

FIG. 5

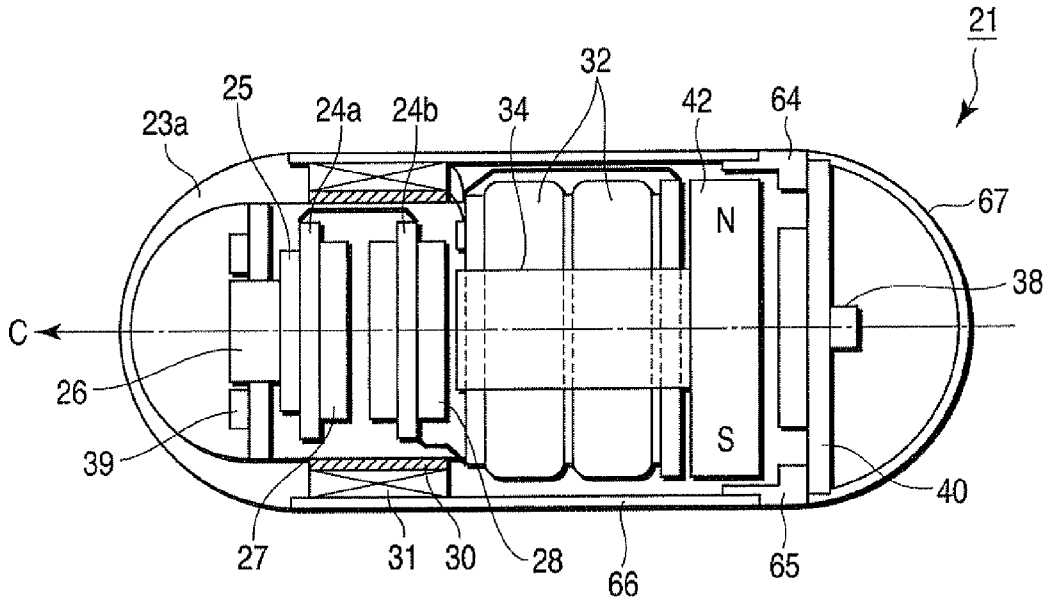

FIG. 6

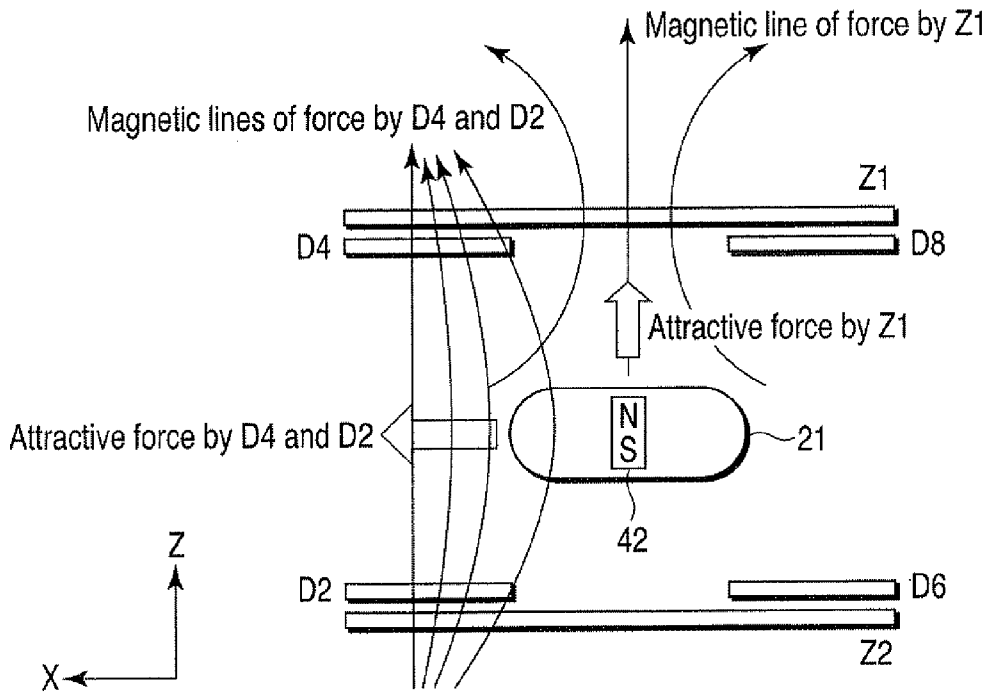

FIG. 7

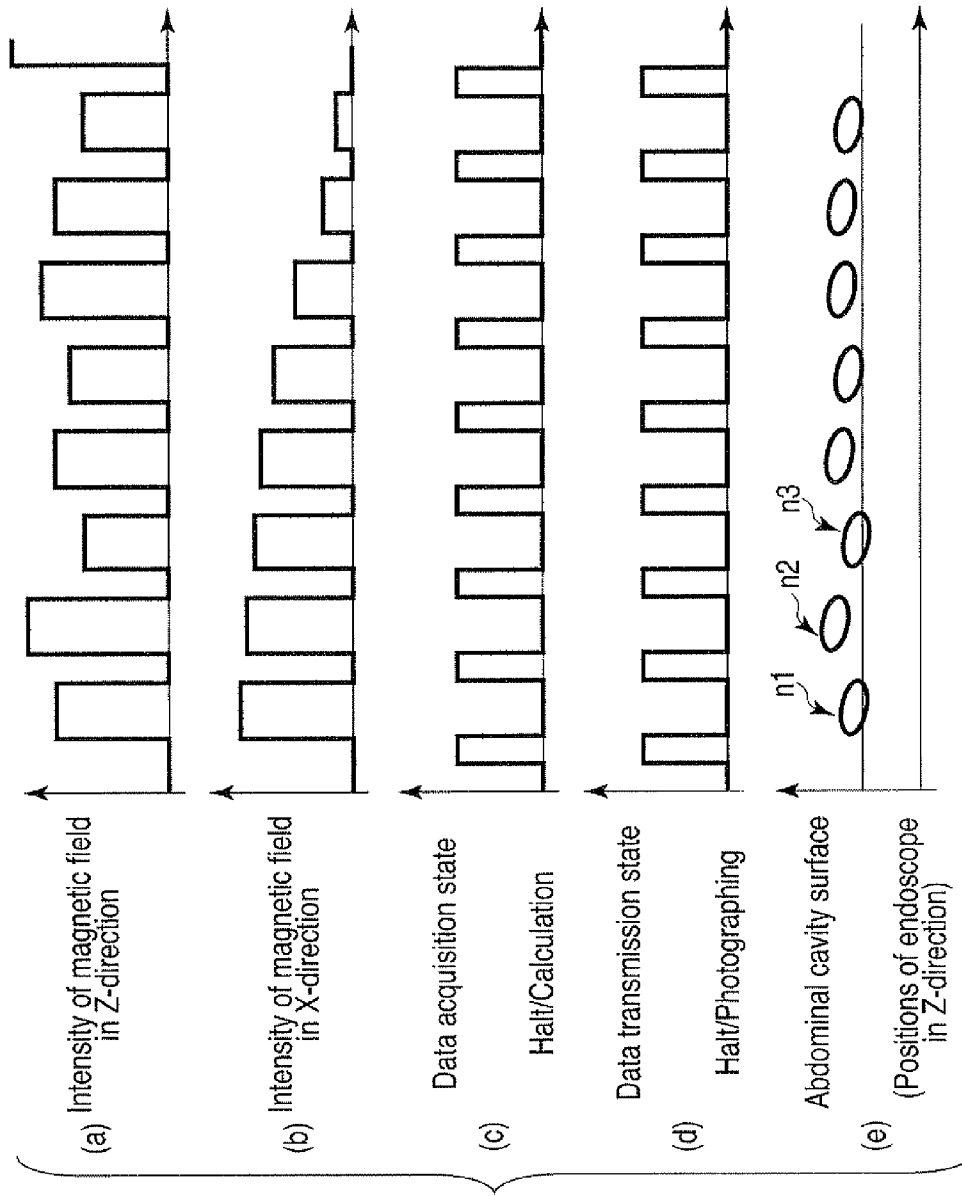

FIG. 8

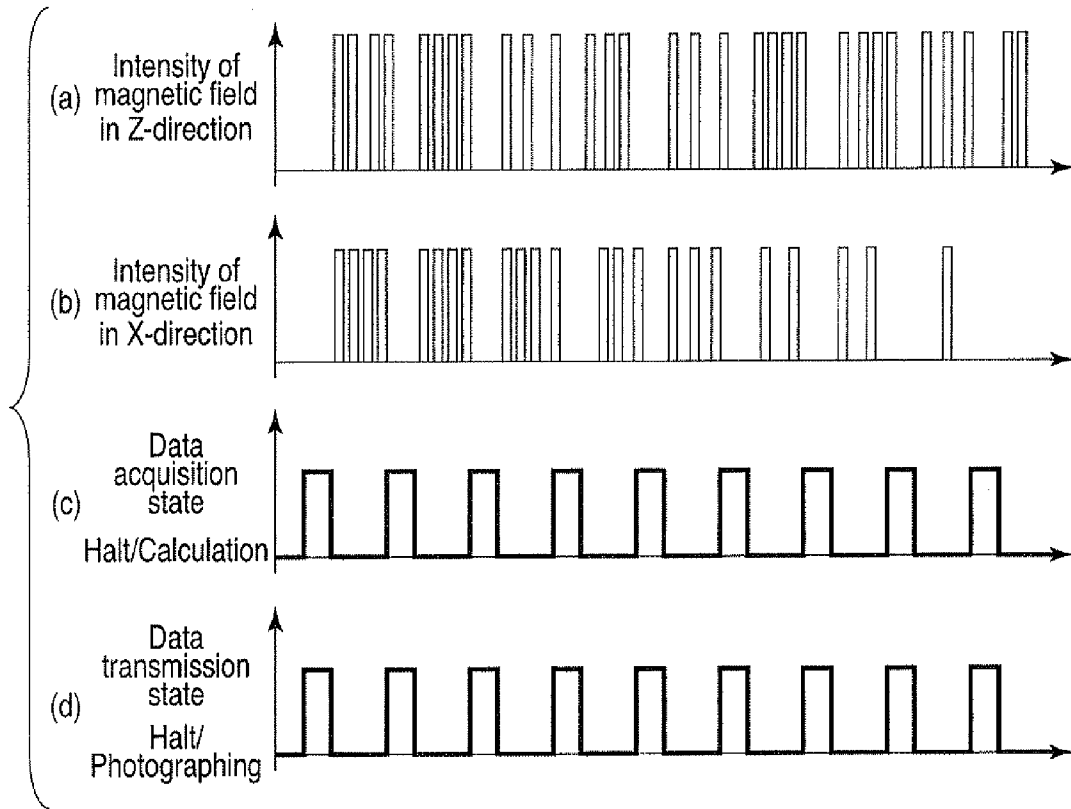

FIG. 9

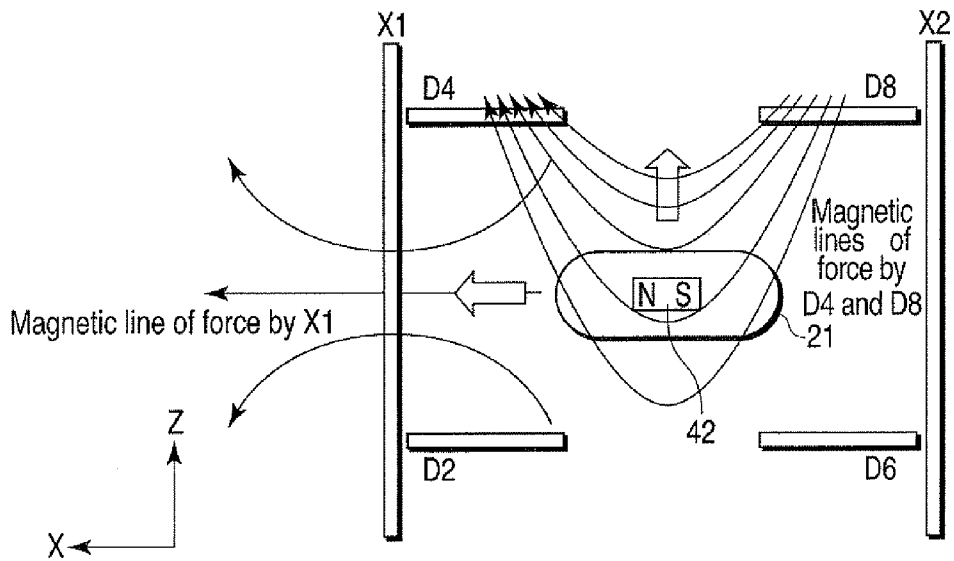

FIG. 10

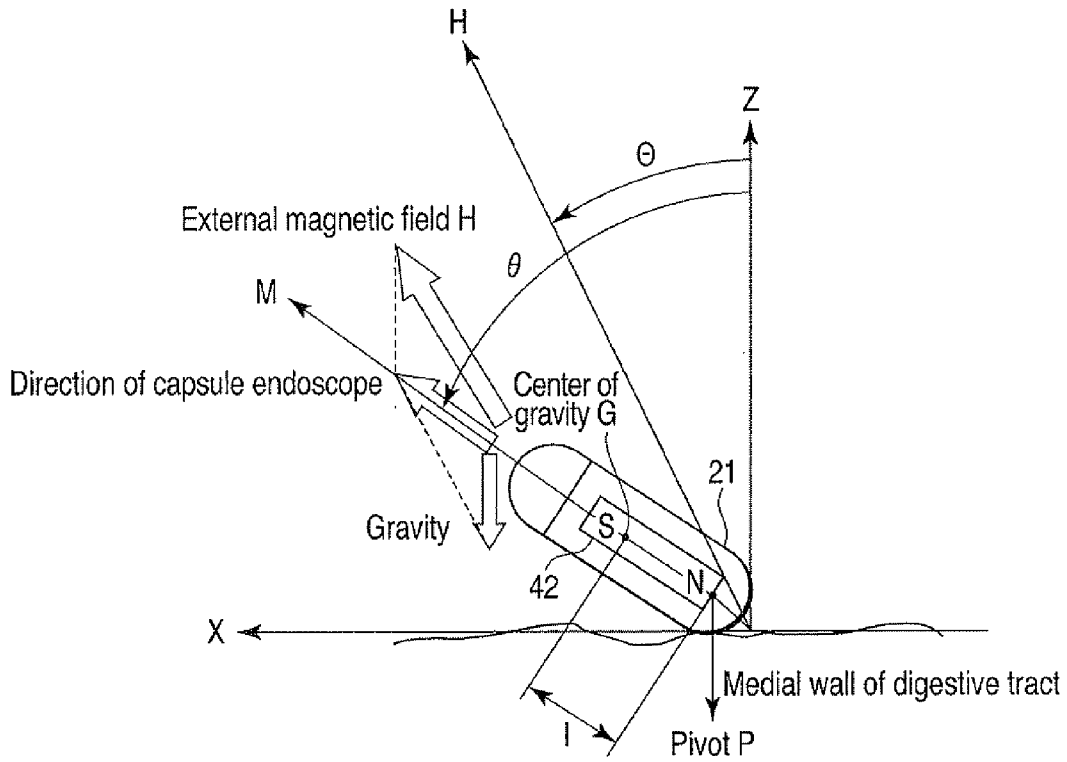

FIG. 11

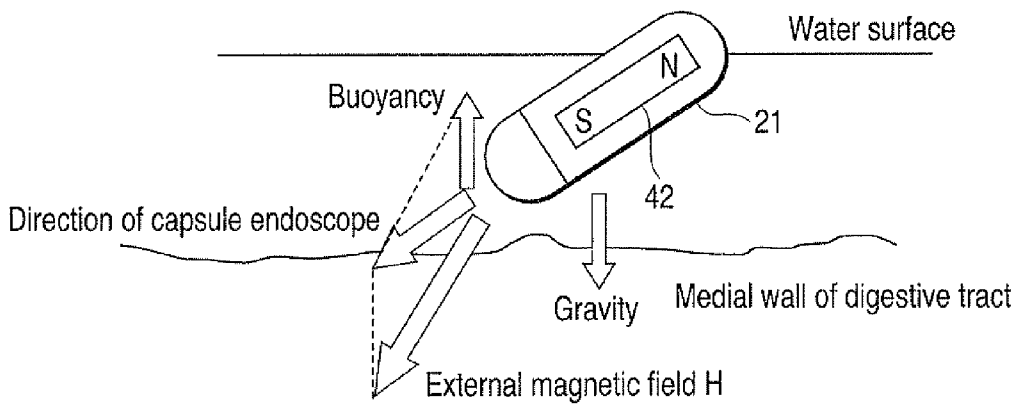

FIG. 12

**ENCAPSULATED MEDICAL DEVICE
GUIDANCE SYSTEM, AND METHOD OF
CONTROLLING THE SAME**

**CROSS-REFERENCE TO RELATED
APPLICATIONS**

[0001] This is a Continuation application of PCT Application No. PCT/JP2006/326146, filed Dec. 27, 2006, which was published under PCT Article 21(2) in Japanese.

[0002] This application is based upon and claims the benefit of priority from prior Japanese Patent Application No. 2005-376277, filed Dec. 27, 2005, the entire contents of which are incorporated herein by reference.

BACKGROUND OF THE INVENTION

[0003] 1. Field of the Invention

[0004] The present invention relates to a guidance system for an encapsulated medical device inserted into an intracavitary for obtaining internal biological information, and a method of controlling the same.

[0005] 2. Description of the Related Art

[0006] Among conventional medical devices for obtaining internal biological information, there is a known encapsulated medical device which periodically transmits image information while moving in an intracavitary.

[0007] As such an encapsulated medical device, a medical device guidance system configured to be magnetically induced has been proposed as disclosed in Jpn. Pat. Appln, KOKAI Publication No. 2004-255174. In this proposal, a medical device guidance system is inserted into an intracavitary, a capsule unit provided with spiral projections around the perimeter contains a magnet magnetized in the direction perpendicular to the longitudinal direction, and the advancing direction of the capsule unit can be smoothly changed by a magnetic field generated by a magnetic field control unit and a rotational magnetic field generator based on operating instructions. By freely changing the capsule unit advancing direction, the direction of the capsule unit can be changed upon taking pictures, and an image of a desired part of the intracavitary can be picked up.

[0008] Jpn. Pat. Appln. KOKAI Publication No. 2003-111720 proposes an apparatus, which takes pictures of an inspection area in the body of a patient by generating a 3D gradient magnetic field for determining the positions of a carrier, which contains a linear magnet and a measuring instrument or a sample collecting device, and functions as a robot to move freely in the body of a patient, by moving it in the body under remote control.

BRIEF SUMMARY OF THE INVENTION

[0009] A first encapsulated medical device guidance system according to an embodiment of the invention has an internal information acquisition unit to acquire internal biological information; a communication unit to output the acquired internal biological information to the outside as an output signal; an encapsulated medical device having a magnet; a magnetic field generator which acts on the magnet, and generates a magnetic field for moving the encapsulated medical device in an objective direction; and a control unit to control the magnetic field generator in synchronization with the output signal sent from the communication unit.

[0010] A second encapsulated medical device guidance system comprises an internal information acquisition unit to

acquire internal biological information; a communication unit to output the acquired internal biological information to the outside as an output signal; an encapsulated medical device having a magnet; a position detector to detect the position of the encapsulated medical device; and a magnetic field generator which acts on the magnet, and generates a magnetic field for moving the encapsulated medical device in an objective direction; wherein the control unit controls the magnetic field generator in synchronization with the output signal, and the position detector detects the position of the encapsulated medical device in synchronization with the output signal.

[0011] A third encapsulated medical device guidance system comprises an internal information acquisition unit to acquire internal biological information; a communication unit to output the acquired internal biological information to the outside as an output signal at regular intervals; an encapsulated medical device having a magnet; a position detector to detect the position of the encapsulated medical device; a magnetic field generator which acts on the magnet, and generates a magnetic field for moving the encapsulated medical device in an objective direction; and a control unit to control the magnetic field in synchronization with the output signal, wherein the control unit receives information about the position and attitude of the encapsulated medical device detected by the position detector, calculates the direction and magnitude of a magnetic field to be generated by the magnetic field generator, while the output signal is being output, and controls the magnetic field generator to generate a magnetic field, while the output signal is not being output.

[0012] A fourth encapsulated medical device guidance system comprises an internal information acquisition unit to acquire internal biological information; a communication unit to output the acquired internal biological information to the outside as an output signal; an encapsulated medical device having a magnet;

[0013] a first magnetic field generator which acts on the magnet, and generates a magnetic field for moving the encapsulated medical device in an objective direction; a second magnetic field generator which acts on the magnet, and generates a magnetic field for reducing the gravity applied to the encapsulated medical device; and a control unit to control the first and second magnetic field generators in synchronization with the output signal.

[0014] A fifth encapsulated medical device guidance system comprises an internal information acquisition unit to acquire internal biological information; a communication unit to output the acquired internal biological information to the outside as an output signal; an encapsulated medical device having a magnet; a magnetic field generator which acts on the magnet, and generates a magnetic field synthesized from a magnetic field for moving the encapsulated medical device in an objective direction and a magnetic field for reducing the gravity applied to the encapsulated medical device; and a control unit to control the magnetic field generator in synchronization with the output signal.

[0015] As a sixth embodiment of the invention, there is provided a method of controlling an encapsulated medical device guidance system, which is a method of controlling a system to guide an encapsulated medical device for observing an intracavitary while moving in an objective direction in an intracavitary, by a magnetic field acting on a magnet provided in an encapsulated medical device, wherein when internal biological information acquired by the encapsulated medical

device in the intracavitary is sent as an output signal, generation of the magnetic field is stopped in synchronization with the output signal in the period of sending the output signal.

[0016] As a seventh embodiment of the invention, there is provided a method of controlling an encapsulated medical device guidance system, which is a method of controlling a system to guide an encapsulated medical device for observing an intracavitary while moving in an objective direction in the intracavitary based on a detected position, by a magnetic field acting on a magnet provided in an encapsulated medical device, wherein when internal biological information acquired by the encapsulated medical device in the intracavitary is sent as an output signal, generation of the magnetic field is stopped, and a position of the encapsulated medical device is detected in synchronization with the output signal in the period of sending the output signal.

[0017] As an eighth embodiment of the invention, there is provided a method of controlling an encapsulated medical device guidance system, which is a method of controlling a system to guide an encapsulated medical device for observing an intracavitary while moving in an objective direction in an intracavitary based on detected position and attitude, by a magnetic field acting on a magnet provided in an encapsulated medical device, wherein a direction and magnitude of the magnetic field to be generated are calculated based on information about detected position and attitude of the encapsulated medical device, while the output signal is being sent, and the magnetic field is generated based on the calculation result, while the output signal is not being sent.

[0018] As a ninth embodiment of the invention, there is provided a method of controlling an encapsulated medical device guidance system, which is a method of controlling a system to guide an encapsulated medical device for observing an intracavitary while moving in an objective direction in an intracavitary based on detected position and attitude, by a magnetic field acting on a magnet provided in an encapsulated medical device, wherein the magnitude of the magnetic field to be generated is controlled by adjusting a duration time of a magnetic field.

[0019] As a tenth embodiment of the invention, there is provided a method of controlling an encapsulated medical device guidance system, which is a method of controlling a system to guide an encapsulated medical device for observing an intracavitary while moving in an objective direction in an intracavitary based on detected position and attitude, by a magnetic field acting on a magnet provided in an encapsulated medical device, wherein the magnitude of the magnetic field to be generated is controlled by adjusting the number of magnetic field pulses.

BRIEF DESCRIPTION OF THE SEVERAL VIEWS OF THE DRAWING

[0020] The accompanying drawings, which are incorporated in and constitute a part of the specification, illustrate embodiments of the invention, and together with the general description given above and the detailed description of the embodiments given below, serve to explain the principles of the invention.

[0021] FIG. 1 is a diagram showing the configuration of an encapsulated medical device guidance system according to an embodiment of the invention;

[0022] FIG. 2 is a sectional view showing the configuration of a first capsule endoscope according to the embodiment;

[0023] FIG. 3 is a sectional view showing the configuration of a second capsule endoscope according to the embodiment;

[0024] FIG. 4 is a sectional view showing the configuration of a third capsule endoscope according to the embodiment;

[0025] FIG. 5 is a sectional view showing the configuration of a fourth capsule endoscope according to the embodiment;

[0026] FIG. 6 is a sectional view showing the configuration of a fifth capsule endoscope according to the embodiment;

[0027] FIG. 7 is a view showing an example of a magnetic field viewed from the Y-axis direction related to guidance, with respect to the first capsule endoscope;

[0028] FIG. 8 is a timing chart for explaining a first method of controlling an encapsulated medical device guidance system;

[0029] FIG. 9 is a timing chart for explaining a second method of controlling an encapsulated medical device guidance system;

[0030] FIG. 10 is a view showing an example of a magnetic field viewed from the Y-axis direction related to guidance, for explaining a third method of controlling an encapsulated medical device guidance system;

[0031] FIG. 11 is a view for explaining an attitude control considering gravity in a capsule endoscope; and

[0032] FIG. 12 is a view for explaining an attitude control considering buoyancy in a capsule endoscope.

DETAILED DESCRIPTION OF THE INVENTION

[0033] Hereinafter, embodiments of the invention will be explained in detail with reference to the accompanying drawings.

[0034] An explanation will be given on an encapsulated medical device guidance system according to one embodiment of the invention shown in FIG. 1. This encapsulated medical device guidance system is largely divided into a capsule endoscope 21 shown in FIG. 2-FIG. 6, and a magnetic guidance unit 1 which generates a magnetic field for guiding a capsule endoscope. As an encapsulated medical device in this embodiment, a capsule endoscope 21 is taken and explained as an example.

[0035] The magnetic guidance unit 1 mainly comprises a guidance coil group (X1, X2, Y1, Y2, Z1, Z2, D1, D2, D3, D4, D5, D6, D7, D8), a power supply 2 for guidance coils, a guidance control unit 3, a controller 4, a sense coil unit 5 (5a-5i), a position detector 6, a receiving antenna unit 7 (7a, 7b, 7c), an antenna selector 8, a receiving unit 9, a display unit 10, a drive coil 11, and a drive coil driver 12.

[0036] Each of fourteen guidance coils X1, X2, Y1, Y2, Z1, Z2 and D1-D8 has an air-core electromagnet, and forms an induction magnetic field generator. In this embodiment, the guidance coils are arranged in each side of a rectangular parallelepiped. As shown by the arrow in FIG. 1, the direction of moving the capsule endoscope 21 forward and backward is assumed to be an X-axis direction, and the axis horizontally perpendicular to the X-axis direction is assumed to be a Y-axis direction, and a gravitational axis vertically perpendicular to the X-axis direction is assumed to be a Z-axis direction.

[0037] On these axis directions, the guidance coils X1 and X2 are placed opposing each other around the surfaces of front and rear sides, forming magnetic lines of force along the X-axis direction, and becoming vertical to the X-axis. In the describe direction, the guidance coil X1 side is assumed to be the front, and the guidance coil X2 side is assumed to be the rear. Moving from the guidance coil X2 to the guidance coil

X1 is assumed to be moving forward, and moving in the reverse direction is assumed to be moving backward.

[0038] The guidance coils Y1 and Y2 are placed opposing each other around the surfaces of both sides, forming magnetic lines of force along the Y-axis direction, and becoming vertical to the Y-axis direction. On one of these sides, two guidance coils D3 and D7 are arranged inside the guidance coil Y1 so as to divide the plane into two parts, and on the other opposite side, two guidance coils D1 and D5 are arranged inside the guidance coil Y2 so as to divide the plane into two parts.

[0039] Similarly, the guidance coils Z1 and Z2 are placed opposing each other around the top and bottom planes with respect to the Z-axis direction, forming magnetic lines of force along the Z-axis direction. In the top plane, two guidance coils D4 and D8 are arranged inside the guidance coil Z1 so as to divide the plane into two parts, and in the opposite bottom plane, two guidance coils D2 and D6 are arranged inside the guidance coil Z2 so as to divide the plane into two parts. In the describe direction, the guidance coil Z1 side is assumed to be the top, and the guidance coil Z2 side is assumed to be the bottom. Moving from the guidance coil Z2 to the guidance coil Z1 is assumed to be moving upward, and moving in the reverse direction is assumed to be moving downward.

[0040] An alternating magnetic field formed by the drive coil 11 acts on the magnetic induction coil 31 and generates an induction current, and a magnetic field is generated from the magnetic induction coil. This alternating magnetic field includes one or more frequency components close to a resonance frequency generated by a coil (magnetic induction coil 31) and capacitor 33 described later provided in the capsule endoscope 21.

[0041] The generated induction magnetic field is detected by the sense coils 5a-5i, a signal including the position information is generated, and the signal is sent to the position detector 6. Based on this signal, the position detector calculates the position and posture information in the capsule endoscope 21. The position and attitude information is sent to the guidance control unit 3, and used for calculation of a magnetic field to be generated by the guidance coil group.

[0042] The group of guidance coils X1, X2, Y1, Y2, Z1, Z2, and D1-D8 is a first magnetic gradient generating means, which generates a magnetic gradient (a first magnetic gradient) to act on the magnet (magnetic substance) in the capsule endoscope 21, and pull the endoscope in a desired direction by moving longitudinally, horizontally and vertically.

[0043] The guidance coil Z1 eliminates the influence of gravity when pulling the capsule endoscope 21 in a desired direction by moving up the endoscope by the above-mentioned guidance coil group, by generating a magnetic gradient (a second magnetic gradient) to act on the magnet in the capsule endoscope 21 to cancel the force of moving down the endoscope moved by the gravity. The guidance coils D4 and D8 can also generate the same force as the guidance coil Z1. The guidance coil Z1 is a second magnetic gradient generating means to eliminate the influence of gravity when moving the endoscope in a desired direction. On the other hand, the guidance coil Z2 eliminates the influence of buoyancy when pulling the capsule endoscope 21 in a desired direction by moving down the endoscope by the above-mentioned guidance coil group, by generating a magnetic to act on the magnet in the capsule endoscope 21 to cancel the force of moving up

the endoscope moved by the buoyancy. The guidance coils D2 and D6 can also generate the same force as the guidance coil Z2.

[0044] Concretely, the opposingly placed guidance coils X1 and X2, Y1 and Y2, and Z1 and Z2 generate a uniform magnetic field within the space surrounded by these guidance coils when a magnetic field is generated in the same direction, and forms a gradient magnetic field when a magnetic field is generated in the opposite direction. The coils S1-D8 can form a highly uniform magnetic field or a gradient magnetic field by driving appropriately. Therefore, by controlling these fourteen guidance coils, it is possible to generate a magnetic field having desired intensity and gradient within a desired space.

[0045] In such arrangement of the guidance coil group, in addition to moving the capsule endoscope 21, longitudinally, horizontally and vertically, it is possible to incline the endoscope to a position rising to the front, for example, by generating a magnetic field to tilt the distal end side up and proximal end side down, by combining the guidance coils X1, X2, Y1, Y2, Z, Z2 and D1-D8.

[0046] These guidance coils are connected to the power supply 2 for guidance coils driven individually. The power supply 2 for guidance coils is controlled by the instruction from the guidance control unit 3, appropriately supplies power to an guidance coil necessary for generating a magnetic field, and generates a desired magnetic field in a desired space.

[0047] In this embodiment, a position detection system (a position detecting means) for detecting the position information of the capsule endoscope 21 comprises a drive coil 11 for generating an induction magnetic field in the coil provided in the capsule endoscope 21, a sense coil group 5 for detecting the induction magnetic field generated in the capsule endoscope 21, a position detector 6 for generating the position information of the capsule endoscope 21 (the position in three-dimensional space and the direction of the capsule endoscope) from the signal based on the induction magnetic field generated by the sense coil group 5, and a drive coil driver 12 for driving the drive coil 11 according to an instruction from the position detector 6.

[0048] Nine sense amplifiers 5a-5i constituting the sense coil group 5 are arranged to be parallel to the side provided with the guidance coil Y1 and uniform in a plane, so that the correct position and attitude of the capsule endoscope 21 can be obtained. In this embodiment, the position related to the Z-axis is detected by providing a pair of opposingly placed the sense coil group 5 and drive coil 11. However, for detecting a three-dimensional position and attitude, it is preferable to provide the pair on each of two crossing planes, for example, top and side planes. To increase the detection accuracy, a few more sense coils is preferable.

[0049] The position detector 6 receives an instruction to specify a position information detection timing from the guidance control unit 3, and drives the drive coil driver 12 based on the instruction.

[0050] The drive coil driver 12 generates a magnetic field by supplying an AC current to the drive coil 11, and generates an induction magnetic field in the capsule endoscope 21 in the magnetic field. Each sense coil of the sense coil group 5 detects a signal based on the induction magnetic field generated from the capsule endoscope 21, and outputs it to the position detector 6. The position detector 6 generates the position and attitude information of the capsule endoscope 21

from the signal based on the induction magnetic field, and outputs it to the guidance control unit 3. The guidance control unit 3 determines a desired moving direction considering the position and attitude information of the capsule endoscope 21 from the position detector 6, and instructs the power supply 2 for guidance coils to generate a magnetic field suitable for moving in that direction. The power supply 2 for guidance coils feeds a current to the guidance coils X1, X2, Y1, Y2, Z1, Z2 and D1-D8 according to the instruction from the guidance control unit 3. Therefore, a magnetic field suitable for that moving is generated by the guidance coils, and the capsule endoscope 21 can be smoothly guided.

[0051] The controller 4 is an input unit, which instructs the advancing direction and gradient of the capsule endoscope 21, by the operation of an input device by the operator, for example, tilting a joystick to a desired direction. In addition to a joystick, buttons arranged to instruct all directions, a touch panel, or a line-of-sight input unit is available as a means to operate the controller 4.

[0052] The guidance control unit 3 receives an instruction signal from the controller 4, position and attitude information from the position detector 6, and signals related to the driving states of the guidance coils from the receiving unit 9, calculates a magnetic force (a magnetic field) for moving the capsule endoscope 21 to a desired position, determines magnetic forces generated by the induction coils X1, X2, Y1, Y2, Z1, Z2 and D1-D8 for generating the magnetic force, and sends an instruction to the power supply for each guidance coil.

[0053] Further, the guidance control unit 3 stops generation of a magnetic field during a communication period over which the image data taken by the capsule endoscope 21 is sent to the receiving unit 9. At the same time, during this communication period, the position detector 6 drives the drive coil 11 based on the instruction from the guidance control unit 3, and acquires position information from the sense coil group 5.

[0054] Three receiving antennas 7 are connected to the receiving unit through an antenna selector 8 for selecting the antennas. These receiving antennas 7 consist of a receiving antenna 7a (AX) for receiving communication data (internal biological information including image data) from the X-axis direction, a receiving antenna 7b (AY) for receiving internal biological information from the Y-axis direction, and a receiving antenna 7c (AZ) for receiving internal biological information from the Z-axis direction. The receiving antennas 7 can detect internal biological information in three axis directions.

[0055] The antenna selector 8 selects the antennas 7a, 7b and 7c to be used for communication. The antenna selector 8 receives the intensity, direction and gradient of a magnetic field generated by the guidance coil group at the position of each antenna, identifies a receiving antenna influenced minimum by the magnetic field, and selects that receiving antenna. By selecting such a receiving antenna 7, the communication between the receiving unit 9 and capsule endoscope 21 can be stabilized.

[0056] The receiving unit 9 sends the guidance control unit 3 the timing of receiving internal biological information from the capsule endoscope 21. As described above, the guidance control unit 3 stops generation of an induction magnetic field by the guidance coil group and drive coil 11, during the communication period for sending internal biological information (image data). Due to this stoppage, the receiving unit

can receive the internal biological information from the capsule endoscope 21 without being influenced by an induction magnetic field. By this stop period, the communication period does not overlap the moving operation and position detection period, and it is possible to eliminate a noise in the internal biological information caused by an induction magnetic field, or an influence of an induction magnetic field on the receiving antenna.

[0057] Therefore, this stop operation is useful in the point that image data is not influenced by a noise, and the receiving antenna is prevented from being influenced by an induction magnetic field, when a magnetic field generated close to the capsule endoscope 21 has high intensity and much gradient, or when a magnetic field generated close the receiving antenna 7 has high intensity and much gradient. Further, even if a magnetic field generated by the guidance coil has high intensity, the position detector 6 can be normally operated.

[0058] The display unit 10 consists of a liquid crystal display, and displays an image taken by the capsule endoscope 21 received the receiving unit 9. When the image is displayed, the data such as photographing situation related to the displayed image may be displayed on the screen together with the image. An explanation will now be given on first to fifth configuration examples in the capsule endoscope 21 according to this embodiment with reference to FIG. 2-FIG. 5.

[0059] FIG. 2 shows the sectional view showing the configuration of a first capsule endoscope according to the embodiment.

[0060] A capsule case 23 of the first capsule endoscope 21 consists of a transparent semiround distal end case 23a placed in the front end side, and a cylindrical proximal end case 23b with a semiround rear end passing infrared rays. The capsule case 23 contains a capsule endoscope described later, and is enclosed watertight. The capsule endoscope 21 advances in the cylinder axial direction indicated by C in FIG. 2.

[0061] An explanation will be given on the capsule endoscope itself.

[0062] A main body of the capsule endoscope is largely divided into an image pickup unit to take pictures of the medial wall surface of a passage in an intracavitary of a patient, a power supply unit to drive the image pickup unit, an induction magnetic field generator to generate an induction magnetic field by the above-mentioned drive coil 11, a magnet to drive the capsule endoscope 21, and a transmission unit to transmit internal biological information including acquired image data to the receiving antenna 7.

[0063] The image pickup unit comprises a photographing optics 26 having a fixed-focus lens, an image pickup element 25 consisting of CMOS or CCD mounted on an image pickup side substrate 24a, an illumination unit 39 consisting of a light controllable LED provided close to the photographing optics 26, and an image processing circuit 27 to perform predetermined image processing for an image signal from the image pickup element 25 mounted on the image pickup side substrate 24a in the rear side of the image pickup element 25. The image pickup side substrate 24a, power supply side substrate 24b, and front side substrate 43 for a cell are sealed with adhesive as a single unit 29 fixed with an adhesive.

[0064] The power supply unit comprises a small cell 32 consisting of a button cell, a pair of substrate 43 (43a and 43b) for a cell provided with a not-shown power supply terminal to take out power from the small cell 32, a heat-shrink tube 34 to fix the small cell 32 just like holding by the cell substrate, a power supply side substrate 24b whose circuit wiring is elec-

trically connected to the circuit wiring of the image pickup side substrate **24** by a flexible substrate, and a power supply circuit **28** provided on the power supply side substrate **24b** and powered by the small cell **32**.

[0065] The magnetic field generator comprises a magnet **30** provided on the perimeter of the adhesive fixed unit **29**, a magnetic induction coil **31** provided through the magnet **30**, and a capacitor **33** provided on the substrate for a cell in the front end side, composing a CL resonance circuit together with the magnetic induction coil **31**.

[0066] The magnetic induction coil **31** is shaped like a ring with a maximum outside diameter a little smaller than the inside diameter of the capsule case **23**. The magnet **30** converges an external magnetic field in the magnetic induction coil **31**. As a magnet **30**, a material with high saturation magnetic flux density and permeability, such as amorphous magnet and fine med (HITACHI KINNZOKU), is suitable. Use of material shaped like a thin film provides an effect of reducing the volume of magnet when placed in a capsule endoscope.

[0067] A circular drive magnet **42** is placed on the rear substrate **43b** for a cell. As a material of the magnet **42**, a neodymium cobalt is suitable, but not limited to this material. The magnet **42** has an N-pole magnetized upward and a S-pole magnetized downward, so that the direction of magnetic lines of force becomes along the Z-axis direction. By setting the polarity as above, the capsule endoscope **21** is always directed to a predetermined direction with respect to the guidance coil group of the magnetic guidance unit **1**. Therefore, the top and bottom of an obtained image can be absolutely determined.

[0068] The transmission unit comprises a communication circuit **36** mounted on the rear side (the magnet **42** side) of a substrate **40** for transmission, an antenna **37** placed on the front surface side (the proximal end case **23b**), a shielding part **35** to cover the exposed communication circuit **36** and to shield a magnetic force of the magnet **42**, and an optical switch **38** which is mounted on the substrate **40** for transmission on the side provided with the antenna **27**, and turns on/off the capsule endoscope.

[0069] In such arrangement, the magnetizing direction of the magnet **42** and the direction of the antenna **37** connected to the transmission circuit **36** are determined by changing the angle by 90 degree. This is done for establishing the condition that the magnetic field generated by the magnet **42** enters at an angle displaced 90 degree from the direction of the antenna **37**. Therefore, the influence of the magnetic field from the magnet **42** upon the antenna **37** is reduced to minimum.

[0070] The shielding part **35** is made of magnetic material, and has an effect to absorb the magnetic field close to the antenna **37**. Therefore, the intensity of the magnetic field applied to the antenna **37** can be reduced, and the influence of the magnetic field on the radio communication between the transmission circuit **36** and antenna **37** can be decreased, and stable radio communication can be realized.

[0071] The optical switch **38** is sensitive to infrared rays. The proximal end case **23b** of the capsule case **23** is made of material to pass infrared rays (in the wavelength sensed by the optical switch) in at least the part close to the optical switch. When infrared rays are applied to the optical switch **38** from a not-shown infrared rays emitter, the optical switch turns on power is supplied from the small cell **32** through the power supply circuit, and photographing and transmission are started. The circuit of the optical switch **38** is configured to

permit a toggle operation. Once infrared rays are applied, the capsule endoscope is kept on. It is permitted to add a configuration, which turns off the endoscope when infrared rays are applied in the on state.

[0072] By the configuration to cover the communication circuit **36** by the shielding part **35**, the influence of the strong magnetic field of the magnet **42** to the transmission circuit and radio circuit (e.g., a noise is superposed, or a communicable distance is reduced) can be reduced. Therefore, clear image data with less noise can be sent to the receiving unit **9**.

[0073] FIG. 3 is a sectional view showing the configuration of a second capsule endoscope according to the embodiment.

[0074] The second capsule endoscope is provided with a spiral part **41** formed by winding a wire with a circular cross section, on the perimeter of the capsule case **23**, unlike the first capsule endoscope. The other parts are the same as the first capsule endoscope, and given the same reference numerals, and an explanation on these parts will be omitted.

[0075] In this configuration, a revolving magnetic field to the second capsule endoscope is formed to a guidance coil group by the drive power supply from the power supply **21** for guidance coils, and the second capsule endoscope **21** is rotated about the axis C in the direction R as shown in FIG. 3. The second capsule endoscope **21** is moved forward or backward along the axis C, according to the direction of rotating the spiral part **41**. Further, as it is possible to rotate the second capsule endoscope **21** in the tilt position, the capsule endoscope can be moved forward or backward in the slanting direction. The second capsule endoscope configured as above provides the same function and effect as the first capsule endoscope.

[0076] FIG. 4 is a sectional view showing the configuration of a third capsule endoscope according to the embodiment.

[0077] The third capsule endoscope is configured by replacing the positions of the magnet **42** and the magnetic induction coil **31** in the first capsule endoscope. The other parts are the same as the first capsule endoscope, and given the same reference numerals, and an explanation on these parts will be omitted.

[0078] Unlike the ring-shaped induction coil **31** in the first capsule endoscope, two linear stick-shaped induction coils **52** and **53** are crossed in the third capsule endoscope. FIG. 4 shows an example of configuration in which the induction coils **52** and **53** are placed in the directions of axes Z and Y. In the vicinity of the induction coils **52** and **53**, capacitors **54** and **55** are placed to connect both ends of the induction coils for forming a LC resonance circuit, and adjusted to obtain a different resonance frequency. The crossed induction coils **52** and **53** generate an induction magnetic field by the magnetic field formed by the drive coil **11**. As the induction coils **52** and **53** are vertical to the axis C and face in different directions, the direction of the axis C (i.e., the capsule endoscope advancing direction) can be detected by obtaining the direction of each induction coil by a respective resonance frequency. Further, in the third capsule endoscope, a magnet **51** is arranged along the cylindrical axis (along the axis C) of the endoscope (with the N-pole set forward and S-pole set backward). Instead of the circular magnet **42** in the first capsule endoscope, a ring-shaped magnet or a barrel-shaped arrangement of stick magnets is provided on the perimeter of the bond fixed part **29**. The third capsule endoscope configured as above can provide the same function and effect as the first capsule endoscope.

[0079] FIG. 5 is a sectional view showing the configuration of a fourth capsule endoscope according to the embodiment.

[0080] The fourth capsule endoscope is configured by replacing the magnet **42**, transmission circuit **36** and antenna **37** in the first capsule endoscope. The other parts are the same as the first capsule endoscope, and given the same reference numerals, and an explanation on these parts will be omitted.

[0081] In the fourth capsule endoscope, the transmission circuit **36** and antenna **37** are enclosed by the shielding part **62**, except the electromagnetic wave emitting direction of the antenna **37**, a window for an optical switch is opened, and the optical switch **38** is placed there. A plurality of optical switch **38** may be provided in different directions. The shielding part is provided adjacent to the substrate **43b** for a cell, and a magnet **63** equivalent to the magnet **42** in the first capsule endoscope is provided in the rear of the substrate. A proximal end case **61** of the capsule case **23** is shaped not semiround, but flat in the rear end. The rear end may be shaped semiround.

[0082] The fourth capsule endoscope configured as above can provide the same function and effect as the first capsule endoscope. Further, with this configuration, the magnetic lines of force close to the antenna **37** can be decreased in the intensity by penetrating through the shielding part **62**. Therefore, deterioration of transmission performance can be prevented by reducing the influence of the magnetic field generated by the magnet **63** on the antenna **37**.

[0083] The amount of magnetic flux entering the substrate can be decreased by evaporating a magnet as a shielding member, or by using a thin film forming technique such as sputtering. Therefore, the circuit formed in the capsule endoscope **21** can be prevented from malfunctioning due to an ill effect of a magnetic field of a magnet and guidance coil.

[0084] FIG. **6** is a sectional view showing configuration of a fifth capsule endoscope according to the embodiment.

[0085] In the first capsule endoscope, the internal biological information (image data) is transmitted wirelessly (by radio waves) by using the communication circuit **36** and antenna **37**. The fifth capsule endoscope uses a so-called electric field communication system. Namely, electrodes **64** and **65** exposed to the capsule case surface are provided, a current signal as internal biological information is flowed between the electrodes through an intracavitary tissue as an examinee, thereby generating an electric field in a living organism, and the internal biological information is received by an electric field sensor fit to the body surface of a patient, instead of the receiving antenna. The other parts are the same as the first capsule endoscope, and given the same reference numerals, and an explanation on these parts will be omitted.

[0086] With this configuration, radio waves are not used as a communication medium, an ill effect on the receiving unit and transmission line is eliminated, a noise is hardly superposed, and a stable clear image is obtained, in addition to the function and effect obtained by the first capsule endoscope. Further, the communication circuit and antenna can be omitted, the configuration becomes simple, and the capsule case can be miniaturized furthermore. By providing a speaker in the transmission circuit and connecting a microphone to the receiving unit, the same function and effect can be obtained by communication using a sound wave.

[0087] Now, an explanation will be given on a first method of controlling an encapsulated medical device guidance system configured as described above.

[0088] FIG. **7** is a view showing an example of magnetic lines of force in a magnetic field viewed from the Y-axis direction upon guidance, with respect to the first capsule

endoscope shown in FIG. **2**. This magnetic field is formed in a space surrounded by the guidance coils **Z1**, **Z2**, **D2**, **D4**, **D6** and **D8**. The capsule endoscope is placed in this space with the distal end facing the direction from the guidance coil **X2** to guidance coil **X1** (in the X-axis direction) shown in FIG. **6**.

[0089] In this magnetic field, the guidance coil **Z1** generates a magnetic force upward in the Z-axis direction as shown in the drawing. The capsule endoscope **21** generates a magnetic field with the intensity weak in the lower direction (the guidance coil **Z2** side) and strong in the upper direction. In the space having such a magnetic gradient, the magnet **42** in the capsule endoscope **21** is given an attractive force in the direction of a strong magnetic field, i.e., upward (called here an upward attractive force).

[0090] Receiving the upward attractive force, the capsule endoscope **21** is moved up in the space. By controlling the strength of the upward attractive force by the guidance control unit **3**, it is possible to make the state that gravity acting upon the capsule endoscope **21** is cancelled. At this time, a magnetic field is formed in the guidance coils **D2** and **D4** as shown in FIG. **7**, and a pulling force for moving forward is generated. Therefore, when the magnetic fields of the guidance coils **D2** and **D4** are superposed on the magnetic field of the guidance coil **Z1**, the capsule endoscope **21** is moved forward while canceling the gravity acting on the endoscope itself.

[0091] In the prior art, the capsule endoscope **21** is moved with its own weight (the mass of the capsule endoscope \times acceleration of gravity) put on the intracavitary tissue. In contrast, in this embodiment, as the capsule endoscope **21** is reduced in its own weight, and moved in the state that a reaction force is weakened by viscosity, the endoscope can be equally moved even by a magnetic field with a lower intensity. However, if this upward attractive force is excessively applied, the capsule endoscope **21** is unnecessarily floated from the intracavitary tissue. Once the capsule endoscope **21** is floated from the intracavitary tissue, the capsule endoscope comes close to the guidance coil **Z1**, the attractive force is weakened furthermore, and the capsule endoscope is suddenly attracted to the guidance coil **Z1** and may be floated over the level desired by the user.

[0092] By controlling as indicated in the timing chart of FIG. **8**, the capsule endoscope is moved while preventing such floating, and communication of internal biological information can be stably performed. FIG. **8(a)** shows the intensity and generation timing of a magnetic field generated by the guidance coil **Z1** to generate an upward attractive force in the Z-axis direction. FIG. **8(b)** shows the intensity and generation timing of a magnetic field generated by the guidance coils **D2** and **D4** to generate a pulling force in the X-axis direction. FIG. **8(c)** shows the timing for the position detector **6** to get signals (position and attitude information signals) based on the induction magnetic field, from each sense coil **5**. FIG. **8(d)** shows the timing of photographing internal biological information, and the timing of transmission and halt of transmission of internal biological information from the capsule endoscope **21** to the receiving unit **9**. FIG. **8(e)** shows the positions of the intracavitary surface and endoscope in the Z-axis direction.

[0093] In this embodiment, the operation timing shown in FIG. **8** is set on the basis of the timing of photographing and transmitting image data by the capsule endoscope **21**. The timing is not to be limited to this, and may be set as appropriate.

[0094] First, the position of the capsule endoscope 21 is detected. When the position is capsule endoscope 21 sinks below the intracavitary surface (n1 in FIG. 8(e)) and the magnetic field intensity is lower than a target value, the magnetic field intensity of the guidance coil Z1 is increased to raise the capsule endoscope (to n2) at the next timing. At this time, if the capsule endoscope 21 is excessively raised, the intensity of generated magnetic field is lowered (n3) at the next timing. The relationship between the positions of the intracavitary surface and capsule endoscope 21 in the Z-axis direction shown in FIG. 8(e) is conceptual, and actually, the capsule endoscope 21 substantially contacts the intracavitary surface, and its weight is not substantially placed on the intracavitary surface (the endoscope does not sink by its own weight).

[0095] At this time, an upward magnetic field in the Z-direction as shown in FIG. 7 is generated in the guidance coils D2 and D4. This magnetic field increases the gradient in the direction from the guidance coil X2 to the guidance coil X1, and becomes a pulling force for the capsule endoscope 21 to be pulled forward along the X-axis direction. Therefore, the capsule endoscope 21 is pulled forward by the guidance coils D2 and D4 with the gravity cancelled by the magnetic field of the guidance coil Z1, and is smoothly moved with less friction on the intracavitary surface.

[0096] As the capsule endoscope 21 advances, the magnetic field generated by the guidance coils D2 and D4 is increased in the gradient at the position of the capsule endoscope, and the pulling force is increased. Namely, the moving speed of the capsule endoscope is increased. To move the capsule endoscope 21 at a constant speed, it is necessary to keep the propulsive force constant. Therefore, the intensity of the magnetic field generated in the guidance coils D2 and D4 is gradually decreased as shown in FIG. 8(b).

[0097] As explained above, the magnetic field intensity is controlled based on the position information of the capsule endoscope 21, the gravity applied to the endoscope is cancelled, and the frictional force acting between the capsule endoscope 21 and intracavitary tissue is decreased. By generating a gradient magnetic field inclined to the direction wanted to move the capsule endoscope 21 in the state that the gravity is cancelled, the operation of guiding the endoscope can be made easy by decreasing the resistance caused by the movement, and the endoscope can be equally moved by a magnetic field with a lower intensity.

[0098] Next, an explanation will be given to a second method of controlling an encapsulated medical device guidance system.

[0099] In this second control method, as shown in FIGS. 9(a) and (b), the intensity of a magnetic field is controlled by the number of applying an on signal with a predetermined short pulse width to a drive signal applied to the guidance coils Z1, D2 and D4 in a period over which one magnetic field is generated. According to this method, a magnetic field is generated like a pulse in each guidance coil, the intervals between the generated magnetic fields are controlled, and the intensity of each magnetic field is controlled as a result. This is realized by adding a known switching circuit to the power supply 2 for guidance coils.

[0100] With this configuration, the guidance coils Z1, D2 and D4 generate a magnetic field like a pulse, and the intensity of each magnetic field is controlled by controlling the intervals between the generated magnetic fields. By this control, the configuration of the power supply for guidance coils can be made simple. An equivalent control method can be realized

by using a PWM (Pulse Width Modulation) control method, which controls the on time (pulse width).

[0101] Next, an explanation will be given to a third method of controlling an encapsulated medical device guidance system. The third control method shown in FIG. 10 realizes similar movement of the capsule endoscope 21 by driving different combinations of guidance coils, unlike the first control method. The third capsule endoscope shown in FIG. 4 is suitable for the third control method.

[0102] In the third capsule endoscope, the magnet 51 is arranged along the cylindrical axis (in the direction of the axis C) of the endoscope (with the N-pole set forward and S-pole set backward). The magnetic induction coils 52 and 53 are crossed (here, perpendicular to each other), and each induction coil is also arranged perpendicular to the direction of the magnetic lines of force of the magnet 51. Further, in the induction coils 52 and 53 in this embodiment, a wire is wound around a core made of a needle-like magnet, and the capacitors 54 and 55 are connected to the induction coils. The L-component or C-component of these two induction coils 52 and 53 is adjusted to have different resonance frequencies.

[0103] In such a configuration, the direction of magnetic lines of force from the magnet 51 can be arranged to be vertical to the longitudinal direction of the induction coils 52 and 53, and the influence of the magnetic field from the magnet 51 can be reduced to minimum, and the direction of the capsule endoscope can be determined by detecting the directions of two induction coils 52 and 53.

[0104] The magnet incorporated in the capsule endoscope 21 shown in FIG. 10 is faced to the advancing direction (in the X-direction shown in FIG. 10) of the capsule endoscope 21, but the same control as shown in FIG. 7 is possible by adding a magnetic field as shown in FIG. 10. Namely, by generating a gradient magnetic field with the intensity gradually increased in the Z-axis direction (upward) by the guidance coils D4 and D8, an attractive force opposed to gravity is formed, and a gradient magnetic field is generated with the intensity gradually increased in the X-direction from the guidance coil X (the direction to the left side), and the capsule endoscope 21 can be moved in the X-direction with the gravity decreased.

[0105] Next, an explanation will be given on the attitude control of the capsule endoscope 21 by referring to FIG. 11.

[0106] An explanation will be given by using the magnetic guidance unit 1 shown in FIG. 1 and the third capsule endoscope 21 shown in FIG. 4.

[0107] First, an explanation will be given on the attitude of the capsule endoscope 21 inclined from the horizontal direction, for example, the tilt position where the distal end portion of the endoscope is raised, and the proximal end portion contacts the digestive organs. To take this position, a first magnetic field advancing upward in the Z-axis direction is generated by using the guidance coils Z1 and Z2 among fourteen guidance coils X1, X2, Y, Y2, Z1, Z2, and D1-D8, and a second magnetic field advancing to the left side in the X-axis direction is generated by using the guidance coils X1, and X2. It is possible to in-line only the first magnetic field generated by the guidance coils Z1 and Z2. A magnetic field synthesized from the first and second magnetic fields is an external magnetic field H in FIG. 11. However, as gravity acts on the capsule endoscope 21, the capsule endoscope 21 does not become parallel to the external magnetic field H. At this time, magnetization of the magnet 42 is assumed to be M, the external magnetic field is assumed to be H, the angle formed

by M and H is assumed to be δ , the mass of the capsule endoscope 21 is assumed to be m, the gravity acceleration is assumed to be g, the angle formed by the Z-direction and the direction of the capsule endoscope 21 is assumed to be θ , the gravity of the capsule endoscope 21 is assumed to be G, the pivot of rotation when the capsule endoscope 21 is faced upward and θ is changed is assumed to be P, and the distance from the pivot P is assumed to be l. At this time, for simplicity, the pivot P can be the center of the semiround shape of the exterior end portion on the side not provided with the image pickup optics 26 in the capsule endoscope 21. By using the above defined items, the following equation is established.

$$\delta = \sin^{-1} \left(\frac{mg \sin \theta}{H \cdot M} \right) \quad \text{[Equation 1]}$$

[0108] According to the equation, a magnetic field may be added in the direction of $\Theta = \theta - \delta$ to direct the capsule endoscope 21 to the θ direction. A magnetic field generated by the guidance coil group is controlled in this way. By adding a magnetic field in the Θ direction, the capsule endoscope 21 can be directed to a desired direction (the θ direction) without being influenced by gravity. When an electric field is formed in the guidance coil X1 to generate an attractive force to pull in the forward direction, for example, while the capsule endoscope 21 is existing in the tilt position in such a magnetic field, the capsule endoscope 21 is moved forward while keeping the tilt position in the state that only the proximal end portion of the capsule case 23 contacts the medial wall of the digestive organs. By moving in this way, the capsule endoscope easily rides over an uneven spot on a pathway on the medial wall of the digestive organs. Further, by superposing an electric field to cancel gravity by using the guidance coil Z1, the capsule endoscope can be moved with a decreased frictional force.

[0109] When water remains in the intracavitary, buoyancy larger than gravity may be generated. In such a state, the capsule endoscope is inclined to a position with the side having a heavier specific gravity to water faced downward, and photographing of a desired part may become difficult. Therefore, in this embodiment, a desired position is realized by forming magnetic fields by a plurality of guidance coil. For example, when water remains on the medial wall of the digestive organs and the distal end of the capsule endoscope 21 is floated, a guidance coil group X1/X2 and Z1/Z2 are used to incline the capsule endoscope to the position as shown in FIG. 12. Namely, the guidance coils Z1 and Z2 are used to form a third magnetic field toward the Z-axis downward, and the guidance coils Z1 and Z2 are used to form a fourth magnetic field toward the X-axis direction. By these magnetic fields, even if the distal end or proximal end portion of the capsule endoscope 21 is floated by buoyancy, the position can be easily controlled and a desired part can be taken as an image.

[0110] As explained herein, in the capsule endoscope system according to the invention, a magnetic field to cancel the gravity applied to the capsule endoscope is formed, the magnetic field is superposed on a magnetic field to move the capsule endoscope or change the attitude of the capsule endoscope, the whole endoscope is floated to reduce the area to contact the intracavitary surface, and a frictional resistance is decreased. Therefore, the capsule endoscope can be easily operated and controlled, an error in movement caused by gravity and sensed by the operator when the capsule endo-

scope is moved or the attitude of the endoscope can be eliminated, and the operation corresponding to the operating amount can be realized.

[0111] Further, as the magnetic fields generated from the position detector and guidance coils are controlled in synchronization with data transmission with the capsule endoscope, the data transmission and position detection can be made without being influenced by the magnetic fields generated by the guidance coils, and the stability of the encapsulated medical device guidance system is improved.

[0112] By controlling the attitude of the capsule endoscope, the capsule endoscope can be moved in the start-up tilt position with the distal end directed upward, and can easily ride over even an uneven area difficult to move on the intracavitary surface on the pathway. Such movement in the tilt position with the distal end or proximal end portion contacting the intracavitary surface can be realized by a magnetic field with the intensity lower than a magnetic field for floating the whole capsule endoscope, and a large output of a power supply for guidance coils is not required, and the capsule endoscope can be miniaturized.

[0113] The present invention is not limited to the described embodiments. Numerous modifications are possible without departing from the spirit and essential characteristics of the invention. Not all components of the embodiments may be mounted, and only the executable components may be used.

[0114] The present invention provides an encapsulated medical device guidance system, which generates a magnetic field environment for an encapsulated medical device to face to a desired direction, eliminates an error in movement caused by gravity acting during operation, decreases a frictional resistance, and works appropriately by a weak attractive force.

What is claimed is:

1. An encapsulated medical device guidance system comprising:
 - an encapsulated medical device having an internal biological information acquisition unit to acquire internal biological information, a communication unit to output the acquired internal biological information to the outside as an output signal, and a magnet;
 - a magnetic field generator which acts on the magnet, and generates a magnetic field for moving the encapsulated medical device in an objective direction; and
 - a control unit to control the magnetic field generator in synchronization with the output signal sent from the communication unit.
2. The system according to claim 1, wherein the control unit stops driving of the magnetic field generator during the period over which the output signal is transmitted.
3. An encapsulated medical device guidance system comprising:
 - an encapsulated medical device having an internal biological information acquisition unit to acquire internal biological information, a communication unit to output the acquired internal biological information to the outside as an output signal, and a magnet;
 - a position detector to detect a position of the encapsulated medical device; and
 - a magnetic field generator which acts on the magnet, and generates a magnetic field for moving the encapsulated medical device in an objective direction,
 wherein the control unit controls the magnetic field generator in synchronization with the output signal, and the

position detector detects a position of the encapsulated medical device in synchronization with the output signal.

4. The system according to claim 3, wherein the control unit stops driving of the magnetic field generator during the period over which the output signal is transmitted, and the position detector detects a position of the encapsulated medical device only during the period over which the output signal is transmitted.

5. The system according to claim 3, wherein the magnitude of the magnetic field to be generated from the magnetic field generator is controlled by adjusting a duration time of a magnetic field.

6. The system according to claim 3, wherein the magnitude of the magnetic field to be generated from the magnetic field generator is controlled by adjusting the number of magnetic field pulses.

7. An encapsulated medical device guidance system comprising:

an encapsulated medical device having an internal biological information acquisition unit to acquire internal biological information, a communication unit to output the acquired internal biological information to the outside as an output signal, and a magnet;

a position detector to detect the position of the encapsulated medical device;

a magnetic field generator which acts on the magnet, and generates a magnetic field for moving the encapsulated medical device in an objective direction; and

a control unit to control the magnetic field in synchronization with the output signal,

wherein the control unit receives information about the position and attitude of the encapsulated medical device detected by the position detector, calculates the direction and magnitude of a magnetic field generated from the magnetic field generator, while the output signal is being sent, and controls the magnetic field generator to generate a magnetic field, while the output signal is not being sent.

8. The system according to claim 7, wherein a magnetic field generated by the magnetic field generator has a magnetic gradient.

9. The system according to claim 7, wherein a magnetic field generated by the magnetic field generator is a rotational magnetic field.

10. The system according to claim 7, wherein the magnitude of the magnetic field to be generated from the magnetic field generator is controlled by adjusting a duration time of a magnetic field.

11. The system according to claim 7, wherein the magnitude of the magnetic field to be generated from the magnetic field generator is controlled by adjusting the number of magnetic field pulses.

12. An encapsulated medical device guidance system comprising:

an encapsulated medical device having an internal biological information acquisition unit to acquire internal biological information, a communication unit to output the acquired internal biological information to the outside as an output signal, and a magnet;

a first magnetic field generator which acts on the magnet, and generates a magnetic field for moving the encapsulated medical device in an objective direction;

a second magnetic field generator which acts on the magnet, and generates a magnetic field for reducing the gravity applied to the encapsulated medical device; and a control unit to control the first and second magnetic field generators in synchronization with the output signal.

13. The system according to claim 12, wherein the second magnetic field generator generates a magnetic field for reducing the buoyancy applied to the encapsulated medical device.

14. The system according to claim 12, wherein the magnitude of the magnetic field generated from at least one of the first magnetic field generator and second magnetic field generator is controlled by adjusting a duration time of a magnetic field.

15. The system according to claim 12, wherein the magnitude of the magnetic field generated from at least one of the first magnetic field generator and second magnetic field generator is controlled by adjusting the number of magnetic field pulses.

16. An encapsulated medical device guidance system comprising:

an encapsulated medical device having an internal biological information acquisition unit to acquire internal biological information, a communication unit to output the acquired internal biological information to the outside as an output signal, and a magnet;

a magnetic field generator which acts on the magnet, and generates a magnetic field synthesized from a magnetic field for moving the encapsulated medical device in an objective direction and a magnetic field for reducing the gravity applied to the encapsulated medical device; and a control unit to control the magnetic field generator in synchronization with the output signal.

17. The system according to claim 16, wherein the magnetic field generator is configured to act on the magnet, and generate a magnetic field synthesized from a magnetic field for moving the encapsulated medical device in an objective direction and a magnetic field for reducing the gravity applied to the encapsulated medical device.

18. A method of controlling a system to guide an encapsulated medical device for observing an intracavitary while moving in an objective direction in an intracavitary based on a detected position and attitude, by a magnetic field acting on a magnet provided in an encapsulated medical device,

wherein when internal biological information acquired by the encapsulated medical device in the intracavitary is sent as an output signal, generation of the magnetic field is stopped in synchronization with the output signal in the period of sending the output signal.

19. A method of controlling a system to guide an encapsulated medical device for observing an intracavitary while moving in an objective direction in the intracavitary based on a detected position, by a magnetic field acting on a magnet provided in an encapsulated medical device,

wherein when internal biological information acquired by the encapsulated medical device in the intracavitary is sent as an output signal, generation of the magnetic field is stopped, and a position of the encapsulated medical device is detected in synchronization with the output signal in the period of sending the output signal.

20. A method of controlling an encapsulated medical device guidance system, which is a method of controlling a system to guide an encapsulated medical device for observing an intracavitary while moving in an objective direction in the

intracavitally based on a detected position and attitude, by a magnetic field acting on a magnet provided in an encapsulated medical device,

wherein a direction and magnitude of the magnetic field to be generated are calculated based on information about detected position and attitude of the encapsulated medical device, while the output signal is being sent, and the magnetic field is generated based on the calculation result, while the output signal is not being sent.

21. A method of controlling a system to guide an encapsulated medical device for observing an intracavitally while moving in an objective direction in the intracavitally based on a detected position and attitude, by a magnetic field acting on a magnet provided in an encapsulated medical device,

wherein the magnitude of the magnetic field to be generated is controlled by adjusting a duration time of a magnetic field.

22. A method of controlling a system to guide an encapsulated medical device for observing an intracavitally while moving in an objective direction in the intracavitally based on a detected position and attitude, by a magnetic field acting on a magnet provided in an encapsulated medical device,

wherein the magnitude of the magnetic field to be generated is controlled by adjusting the number of magnetic field pulses.

* * * * *