

*E.O. & C.B. Thompson,*

*Horse Power.*

*No. 107,309.*

*Patented Sept. 13. 1870.*

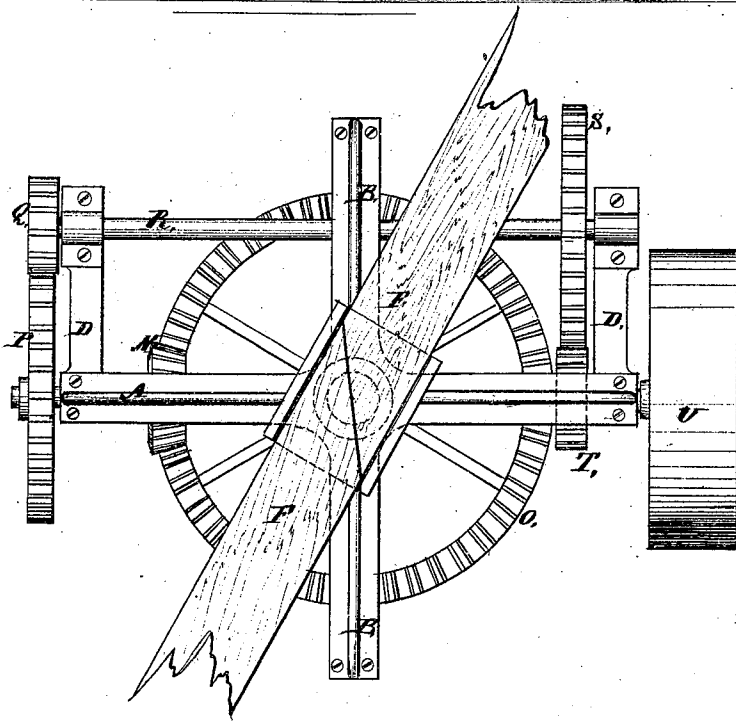
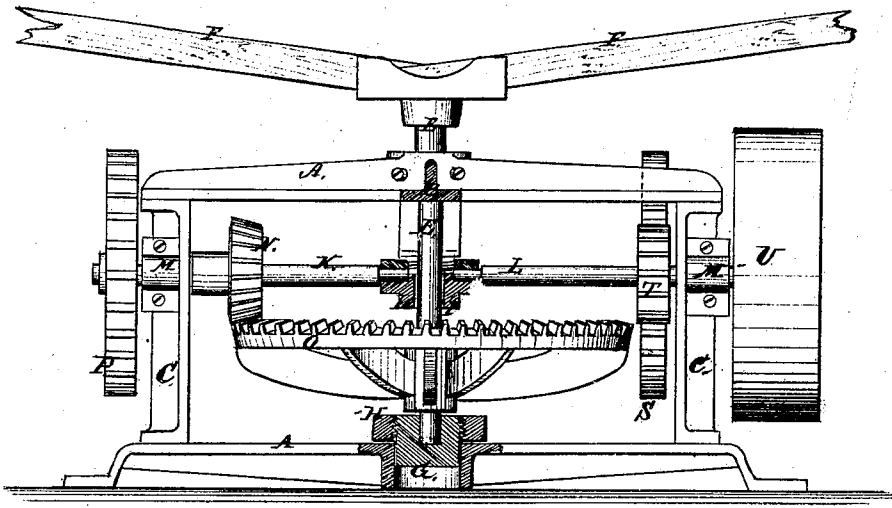

**Witnesses:**

*Craz Nida*  
*S. S. Mabee*

**Inventor:**

*E. O. Thompson*  
PER *J. B. Thompson*  
*Wm. O.*  
**Attorneys.**

# UNITED STATES PATENT OFFICE.

EDWARD O. THOMPSON AND CHARLES B. THOMPSON, OF THOMASVILLE, GA.

## IMPROVEMENT IN HORSE-POWER APPARATUS.

Specification forming part of Letters Patent No. **107,309**, dated September 13, 1870.

*To all whom it may concern:*

Be it known that we, EDWARD O. THOMPSON and CHARLES B. THOMPSON, of Thomasville, in the county of Thomas and State of Georgia, have invented a new and Improved Horse-Power; and we do hereby declare that the following is a full, clear, and exact description thereof, which will enable others skilled in the art to make and use the same, reference being had to the accompanying drawing, forming part of this specification.

This invention relates to improvements in horse-powers; and consists in an improved arrangement of the supporting-frame and operating machinery, calculated to provide a simple and cheap apparatus for use either on the floor or for attachment, so as to be suspended in an inverted position from the beams or frame of a gin-house or other building, all as hereinafter described.

Figure 1 represents a side elevation of our improved machine, partly sectioned, and Fig. 2 is a plan view of the same.

Similar letters of reference indicate corresponding parts.

The frame is composed of the lower and upper cast-metal horizontal cross-bars, A A and B B, the posts C, and the lateral arms D, the bars A B crossing each other perpendicularly at the center, and having vertical holes thereat for the support of the vertical shaft E, to which the sweeps F are connected, for the attachment of the animals. The hole through the bottom bars, A B, is made large, and receives an adjustable step, G, for the shaft E, which is raised or lowered by a nut, H. The upper bars, A B, support around the shaft E the pendent bearings I for the inner ends of

the shafts K L, which are supported near the outer ends in the posts C and the boxes M. The shaft K has inside the posts C, on which it is supported, a small bevel-wheel, N, gearing with the large driver O on the vertical shaft, and outside of the said posts is a large spur-wheel, P, gearing with a pinion, Q, on the counter-shaft R, journaled in the ends of the arms D, and carrying near the opposite end a large spur-wheel, S, driving the small pinion T on the shaft L, which carries at the outer end the pulley U, by which the motion is transmitted by a belt in any suitable way.

This power may be set on the ground or the floor of a building, as shown in the drawing, or it may be inverted and suspended from the beams or frame of a building by bolting through the ends of the lower bars, A B, or by any other suitable means.

This arrangement of the frame is very simple and cheap, requiring but little fitting after the parts are cast, and the arrangement of the working parts is such that a high speed is obtained with but few and simple parts.

Having thus described our invention, we claim as new and desire to secure by Letters Patent—

1. The frame constructed and arranged as described.
2. The combination and arrangement of the operating parts, together and with the frame, substantially as specified.

EDWARD O. THOMPSON.  
CHARLES B. THOMPSON.

Witnesses:

JAMES A. BROOKS,  
H. H. TOOKE.