



(19) **United States**

(12) **Patent Application Publication**
Hooley et al.

(10) **Pub. No.: US 2004/0101150 A1**

(43) **Pub. Date: May 27, 2004**

(54) **PIEZOELECTRIC DRIVER DEVICE WITH INTEGRAL SENSING LAYER**

international application No. PCT/GB98/02675, filed on Sep. 4, 1998.

(75) Inventors: **Anthony Hooley**, Cambridge (GB);
David Henry Pearce, Birmingham (GB)

(30) **Foreign Application Priority Data**

Sep. 5, 1997 (GB) 97/18,785.0
Mar. 11, 1998 (GB) 98/05,053.7
Mar. 19, 1998 (GB) 98/05,735.9

Correspondence Address:
SYNNESTVEDT & LECHNER, LLP
2600 ARAMARK TOWER
1101 MARKET STREET
PHILADELPHIA, PA 191072950

Publication Classification

(51) **Int. Cl.⁷** **H04R 25/00**
(52) **U.S. Cl.** **381/190**

(73) Assignee: **1..Limited**, Cambridge, ENG

(57) **ABSTRACT**

(21) Appl. No.: **10/716,819**

A unimorph or bimorph piezoelectric 'bender' formed into a flat- (or edge-) wound helix (**50,54,55**) wherein there is an additional laminate layer of a piezo-resistive material (**609, 709**) the function of which is for sensing and responding to the actual deflection of the bender device. It also discloses a method for making this type of device by co-extrusion of a sinterable paste of the appropriate composition.

(22) Filed: **Nov. 19, 2003**

Related U.S. Application Data

(62) Division of application No. 09/508,009, filed on Mar. 6, 2000, now Pat. No. 6,677,034, filed as 371 of

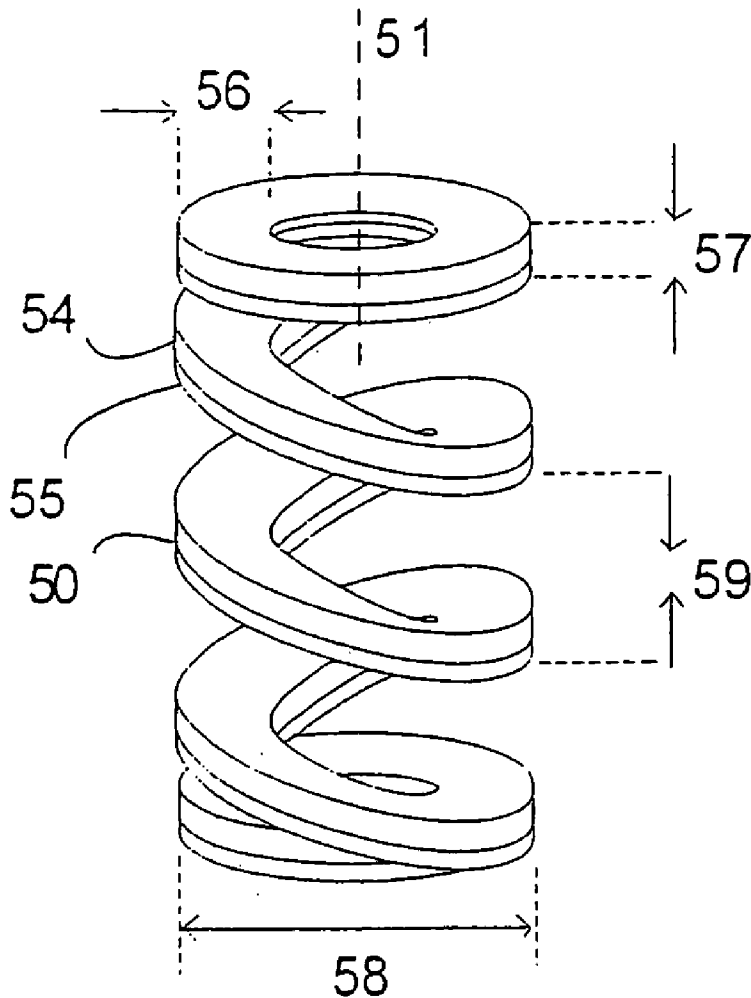

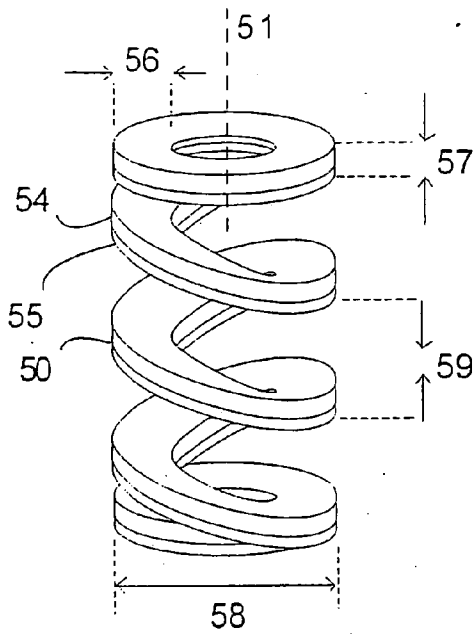

Fig. 1

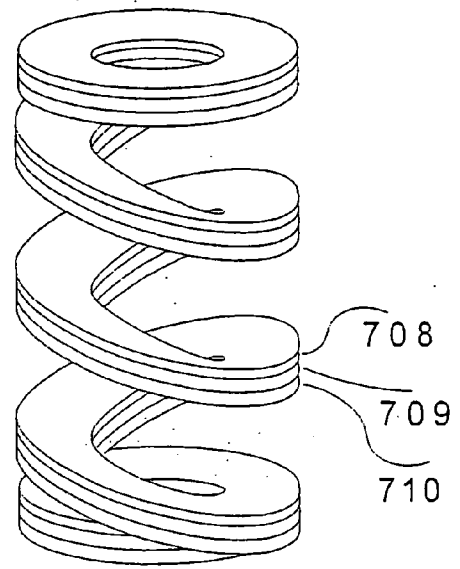

Fig. 2A

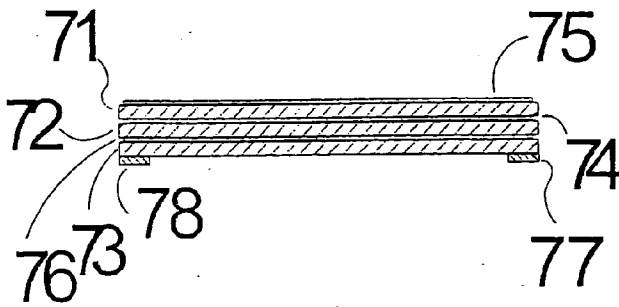

Fig. 2B

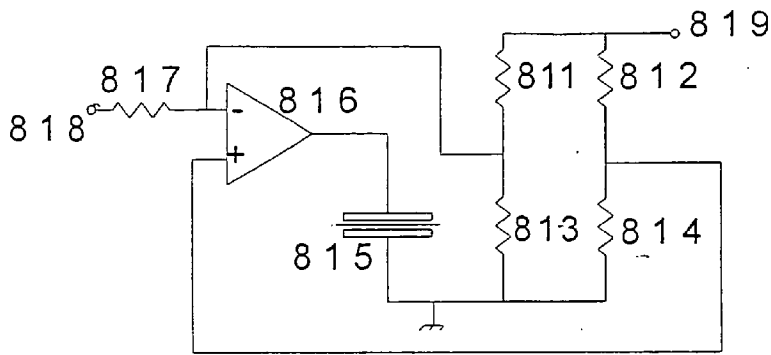

Fig. 3

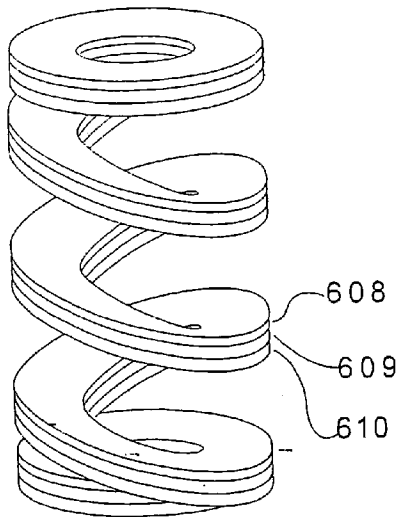

Fig. 4A

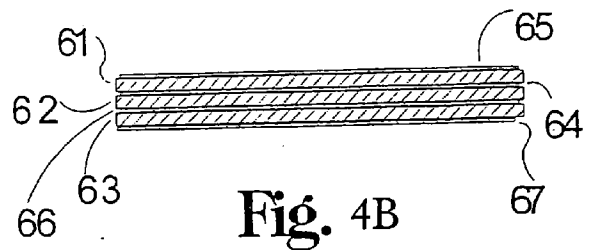

Fig. 4B

PIEZOELECTRIC DRIVER DEVICE WITH INTEGRAL SENSING LAYER

BACKGROUND OF THE INVENTION

[0001] This invention relates to piezoelectric devices. More particularly, the invention relates to novel constructions of piezoelectric devices with integral positioning and control mechanisms. This invention relates to the field of actuators and sensors, and in particular to unimorphs, bimorphs and multimorphs made of piezoelectric material.

[0002] Piezoelectric actuators of many types are well known in the art. The direct piezoelectric effect is generally rather a small effect, of the order of 10^{-10} m/v, so that to get substantial deflections using the effect either very high drive voltages are required or a large stack of low-deflection piezoelectric devices must be used. In either case, the achievable deflections are limited practically to the low-micron range.

[0003] When a greater deflection is required, various configurations of “bender” are used. A bender is a two-layer device wherein a piezoelectric layer is laminated (and intimately bonded together) with either a non-piezoelectric layer (making a unimorph) or a piezo-electric layer (a bimorph). In a unimorph, when the piezoelectric layer expands or contracts under the influence of a drive voltage, the laminate as a whole is caused to bend due to the differential deflection between the laminate’s layers. In the bimorph—two piezoelectric layers laminated together—the two layers are poled and then connected to the drive voltage in such a way that when one layer of the laminate expands due to the drive voltage, the other contracts, and vice versa. In this way, the laminate again bends due to the differential deflection between the laminate layers.

[0004] It is also known to stack multiple layers such as have been described, either to achieve greater deflection output-force, or, by using multiple thinner layers, to achieve a comparable output force from a lower drive voltage, or for both of these reasons.

[0005] In this way, such piezoelectric benders as are presently available can produce substantial deflections—on the order of millimetres—with drive voltages as low as 30V to 60V.

[0006] Unfortunately, piezoelectric materials able to produce large deflections per volt (“high activity” materials), are also prone to considerable hysteresis. The generally undesirable result of this is that an actuator comprising such a piezoelectric bender is difficult to control precisely, because the hysteresis eliminates the possibility of there existing a simple relationship between input drive voltage and output deflection.

[0007] A similar effect results from the fact that piezoelectric materials have non-negligible compliance. In the case of their use as a bender-type actuator, the external load applied to the actuator will also determine to an extent, the amount of output deflection.

[0008] Thus conventional benders have shortcomings for precision actuator service. The present invention proposes a surprisingly simple solution to these problems.

BRIEF SUMMARY OF THE INVENTION

[0009] According to the present invention, there is provided a bender structure piezoelectric device wherein there

is an additional laminate layer of a piezo-resistive material the function of which is for sensing and responding to the actual deflection of the bender device.

[0010] Thus, the present invention suggests in essence the addition to the bender structure of a further laminate layer of a piezo-resistive material the function of which added layer is (solely) for sensing and responding to the actual deflection of the bender device. If this additional sensing layer is made of a very low hysteresis piezo-resistive material, then when the bender is deflected, the resulting activity response of the sensing layer will be largely free of hysteresis effects (the selection of the material for this sensing layer may be made on grounds of low hysteresis and high piezo-resistive response alone, as it plays no active part in causing the deflection of the bender). Furthermore, if this sensing layer be made of as high-compliance a material as possible—either by choice of the piezo-resistive material, or simply by making the layer sufficiently thin, or both—then the presence of the sensing layer minimally loads the primary bender device, and so it has little effect on the device’s output deflection. Finally, if the control system driving the bender be provided with the appropriate inputs and outputs, it can then use the output signal from the sensing layer in a feedback loop to control closely the actual output deflection, largely free of hysteresis errors, and also independently of the mechanical loading of the device.

[0011] Such a sensing layer may be added to any of the unimorph, bimorph, single- or multiple-layer benders of all kinds that are currently known, in order to provide direct feedback of the deflection state of the bender, and thus greatly to simplify the precise control of such a bender. And the bender may be a flat- (or edge-) wound helical device, or it may be one of the tape-wound helical devices the subject of GB-A-2,322,232.

[0012] The added sensing layer used in the present invention is a piezo-resistive material. A piezo-resistive material is one the electrical resistance of which changes as it is mechanically deformed. The control system applies a voltage and detects the change in current and thus resistance, or applies a current and detects the change in voltage.

[0013] The sensing layer may be added to either of the outside layers of the laminate structure, or indeed, added as one of the inner layers of the structure. For example, it may be arranged to be the layer closest to the neutral axis of the bender, generally near the centre of the bender layer-stack, so as the better to detect the average deflection of the bender structure. Positioning the sensing layer close to the neutral axis also subjects the sensing layer to the least strain, and thus minimises hysteresis effects.

[0014] Although the bender structure of the invention need only have a single added layer, it can have two or more. Thus, two (or more) sensing layers may be added to the bender structure in such a manner as to minimise hysteresis effects in the sensing layers by arranging for some cancellation of the hysteresis effects between the layers when used in combination. In one such arrangement, a differential amplifier can be used to sense the difference of the output signals from two such sensing layers to provide a net signal from the sensing layers that more precisely indicates the actual deflection of the bender. The added sensing layers may each be arranged to sense the strain in the bender, whereafter, by suitable electronic techniques, their deflec-

tion sensitive signals may be made to add (for example in a differential amplifier) while their temperature dependent and other non-strain-related resistance changes may be made to largely cancel in the electronics sensing circuitry.

[0015] Where benders are fabricated by bonding previously separate layers of piezoelectric material together, then the sensing layer may also be bonded into the laminate so constructed, and may, for example be made of a totally different type of material optimized solely for its sensing rather than its deflecting properties. For example, piezo-resistive polymers have much higher compliance than equivalent thickness piezo-resistive ceramics, and whilst in some cases they are less sensitive than some piezo-resistive ceramics they are nonetheless good candidates for this sensing layer application because of their low cost, high compliance, and the ease with which they may be bonded and fabricated.

[0016] Where benders are fabricated from two or more layers of piezoelectric ceramic (bimorphs or multimorphs) and/or one or more layers of non-piezoelectric material together with one or more layers of piezo-resistive ceramic (unimorphs or multimorphs), and where such lamination is carried out prior to the firing or sintering process (i.e. at the “green” ceramic stage), then it is still possible to add one or more sensing layers of piezo-resistive ceramic at this same “green” stage, before firing, and to choose the material of the sensing layer on the grounds of suitability for sensing rather than of deflecting under drive voltage (e.g. the choice is for low hysteresis, and/or high compliance, and/or high sensitivity). Alternatively, the sensing layers may be bonded onto such “fired laminates”, after firing, in which case non-ceramic sensing layers such as piezo-resistive polymers may be used in addition to high-temperature-resistant piezo-resistive ceramics.

[0017] In particular, the piezo-resistive ceramic extrusion and calendaring processes pioneered by Pearce et al may be used to produce, in one manufacturing process, a multilayer bender device complete with deflecting layer(s) and piezo-resistive sensing layer(s), with electrodes fired in during one and the same process.

[0018] In the manner described, a piezoelectric actuator may be constructed such that, with a suitable control system able to make use of the deflection feedback signal available from the sensing layer(s), it is capable of precise control without the need for any additional external position sensing devices—and thus it can be made at significantly reduced cost.

[0019] One preferred candidate material for the piezo-resistive sensing layer is ruthenium oxide. This material may be applied in some appropriate manner as a thick film to a surface of a bender structure, possibly over the top of an insulating thick-film layer, then “cured” (sintered) to form the required ceramic structure. Thick film layers of this kind have the advantage of requiring only a relatively small quantity of the piezo-resistive material, which permits the construction of a low-cost sensing layer. Suitable application processes include the conventional methods of thick-film technology, including screen printing, doctor blading, painting and spraying techniques. In this case the piezoresistive material is applied to the bender structure in the form of an “ink” being a mixture of, amongst other components, piezo-resistive, conductive and binding agents. Whilst the piezo-

resistive layer(s) may be embedded within the bender structure, in a preferred embodiment the layer(s) are applied post-sintering, to maximise signal and minimise reactions.

[0020] One particular application for a bender-type piezoelectric device of the invention—one having an integral sensing layer—is an acoustic transducer, wherein the bender is arranged to produce movement in the air, and thus sound waves, in response to an input drive voltage (an electrical signal representing the sound), in the manner of a loudspeaker. In general, because of the aforementioned hysteresis and load-dependent deflection effects, such transducers can be significantly non-linear, which is generally undesirable, as it produces distortion in the output sound. The provision of one or more integral piezo-resistive sensing layer easily and cheaply provides sensing signals which may be used in a feedback control system to eliminate the greater part of such non-linearities, and thus to minimise such acoustic distortions.

[0021] Piezoelectric transducers that can benefit from the present invention include the type of device the subject of GB-A-2,322,232 aforementioned. This device is an alternative helical actuator which is more similar to a simple bender (but in this case a bender that has been coiled helically) than to the Pearce device. If, however, there is added to the helical bender actuator one or more additional piezo-resistive sensing layer—in this case as an additional laminate layer coiled helically conformally with the deflecting layers—the added layer(s) can then be used to sense the deflection of the helical actuator and to provide a feedback signal able to assist accurate control of the actuator. In so doing, of course, there can be reduced the effects both of hysteresis in the piezoelectric material of the actuator and also of the loading on the actuator. With a suitable feedback control system, substantially linear operation of the actuator is possible, making it suitable for use in, for example, an acoustic transducer.

[0022] Of course, if the piezoelectric material of a bender is operated largely in the approximately linear region, and is so chosen to have as low a hysteresis as possible, then inherent hysteresis effects may be made quite small, at least for AC signals. However, for DC drives, and for partially static loads, the addition of the sensing layer will provide information about the actuation point of the bender, by measuring the strain, and can thereby provide signals able to be used to reduce greatly the effects of varying loads on the actuation point.

[0023] In order to achieve better linearity of the piezo-resistive sensing layer around the zero strain point of the bender, the sensing layer may be bonded to the bender (in the post-sintering method of construction) whilst the bender is maximally deflected in the direction that would normally apply compressive strain to the piezo-resistive layer, and the bender deflection maintained until the bonding process is complete. In this way, during all regions of normal operation of the bender, the piezo-resistive sensing layer will be in tension and so will for the most part operate well away from the zero-strain region.

[0024] As an alternative to a piezo-resistive sensing layer the sensing layer may be of other piezo-active material such as piezoelectric material. One preferred candidate for the piezoelectric sensing layer is the same (active) PZT material from which the underlying bender is fabricated, eg Morgan-

Matroc PZT-4D, PZT-5A or PZT-5H (=Navy Types I, II and VI). Alternatively, where the piezoelectric sensing layer is laminated by bonding onto the bender after the bender has been sintered, the sensing layer may be made of PVDF piezoelectric polymer.

[0025] If the bender itself is made of piezoelectric polymer (no sintering step) then the sensing layer—of, say, PVDF—may be added at the same time as the bender is fabricated.

BRIEF DESCRIPTION OF THE DRAWINGS

[0026] In the drawings:

[0027] FIG. 1 shows a perspective view of a form of piezoelectric helical bender which is not an embodiment of the invention;

[0028] FIGS. 2A & 2B show, respectively, a perspective view of a piezoelectric helical bender, using a piezo-resistive sensor layer, and also a section through a more conventional type of bender but using a sensor layer according to the invention;

[0029] FIG. 3 shows a circuit diagram of a simple feedback control system for use with piezoelectric benders such as are shown in FIGS. 2A and 2B; and

[0030] FIGS. 4A & 4B show both a perspective view of an alternative version of piezo-active helical bender, using a piezoelectric sensor layer, and also a section through a more conventional type of bender but using a sensor layer.

DETAILED DESCRIPTION OF THE INVENTION

[0031] Embodiments of the invention are now described, though by way of illustration only, with reference to the accompanying diagrammatic drawings.

[0032] FIG. 1 shows a helical flat-wound bender of some suitable diameter, thickness, pitch and width (shown respectively at 58, 57, 59 and 56), which is not itself an embodiment of the invention, but is useful for understanding.

[0033] The bender is comprised of a top (as viewed) layer 54 and a bottom (as viewed) layer 55 bonded together at their interface 50. If both layers 54,55 are piezoelectric then the bender is a bimorph; if only one layer is piezoelectric then it is a unimorph.

[0034] The helix extends or contracts along the direction of the axis (shown as dashed line 51) depending on the polarity of the electrical drive voltage applied between conductive electrodes (not shown) deposited one on the top (as viewed) face of the top layer 54 and one on the bottom (as viewed) face of the bottom layer 55. To allow easy application of load forces, the top and bottom turns of the helix may be flattened out somewhat as indicated in FIG. 1, or they may be ground flat.

[0035] FIGS. 2A,2B show simple bimorph “benders”, one “helical” (like that of FIG. 1) and one “linear”, to each of which has been added a sensing layer to form an embodiment of the present invention.

[0036] The simple bimorph bender of FIG. 2B is of a generally conventional type wherein two layers of piezoelectric material 71,72 are bonded together, with an optional electrode 74 between them, and electrodes 75,76 attached

such that a drive voltage may be applied to the opposing faces of the structure so formed. Also shown in FIG. 7B is an additional layer of piezo-resistive material 73 which plays no part in the bender deflection process when layers 71,72 are driven (other than to impede it somewhat by virtue of its finite compliance), which layer 73 is bonded to electrode (layer) 76 with an intervening insulating layer (not shown) to electrically isolate it therefrom. Additional electrodes 77,78 are arranged on that face of layer 73 not bonded to layer 72 (via the insulating layer and electrode 76), one on each end of the piezo-resistive material of the layer 73, in order to provide a signal output from this layer when deflected by the bender action of layers 71,72.

[0037] FIG. 2A shows a helical bender much like that of FIG. 1, and with two electrically-driven piezoelectric layers (709,710: the associated electrodes are not shown), save that it includes a further piezo-resistive laminate layer 708. This extra layer plays no active role in deflecting the structure, but is used instead to provide a feedback signal (to sensing electronics, not shown) about the actual deflection of the bender when in use. The sensing layer 708 is bonded to active layer 709 and its electrode via an intervening insulating layer (not shown) so as electrically to isolate the sensing layer 708 from the active layer. The sensing layer 708 also has electrodes (again, not shown), one at each end of the helical structure, for connection to the sensing circuitry.

[0038] In use, a voltage is driven between the top (as viewed) of active layer 709 and the bottom of active layer 710, which layers have been previously poled in an opposite sense to each other. This causes the ribbon-like structure (which has been edge-, or flat-, wound into a helix) to bend, and this deflection causes the helix as a whole to lengthen or shorten depending on the sign of the drive voltage. The piezo-resistive sensing layer 708, being securely bonded to or fired onto active layer 709, is also deflected by this bender activity, and in so doing, and being piezo-resistive, produces a resistance change along its length which may be converted to a voltage signal by the passage of a current through it (via its electrodes, which signal may be used as a feed back signal to sense and/or control the deflection of the helical bender.

[0039] FIG. 3 shows a typical driver circuit incorporating a “bender” with piezo-resistive sensor layer feedback.

[0040] In FIG. 3 there is shown a differential operational amplifier 816 is used in a classic negative-feedback circuit to drive a bender 815, from an input demand signal (fed in at input 818) which is connected to the inverting input of the amplifier 816 via a resistor 817. In one version of this circuit, resistor 813 represents the piezoresistive sensing layer integrated with the bender 815, and a current is made to pass through this resistor from a DC voltage supply 819 via a resistor 811. A voltage therefore appears across resistor 813 proportional to its resistance, and therefore with a component proportional to the strain experienced by the sensing layer resistor 813. The voltage at the junction of the resistors 811,813 is connected to the inverting input of the amplifier 816 as a negative-feedback signal. A further pair of resistors 812,814 are used to produce an offset voltage the same value as the voltage at the junction of the resistors 811,813 when the bender and sensing resistor are in the unstrained or undeflected state. This offset voltage is connected to the non-inverting input of the amplifier 816.

[0041] In operation, when the input voltage **818** is set to some demand value within the range of operation of the circuit, the output of the amplifier **816** drives the bender to an operating point which causes strain in the sensing layer piezo-resistor **813** and changes its value. This modifies the voltage at the junction of resistors **811,813**, which in turn modifies the differential input voltage applied to the amplifier **816**. If the sense of the resistance change is correctly chosen with respect to the drive voltage applied to the bender **815** (i.e. the polarity of the connection to the bender is such as to ensure that negative- and not positive-feedback is achieved), the circuit rapidly settles to a point where the drive to the bender **815** is just such as to produce a deflection or strain proportional to the input voltage **818**.

[0042] An improved version of the arrangement shown in **FIG. 3** may be constructed as follows.

[0043] In this arrangement, both resistors **813, 814** represent piezo-resistive sensing layers integrated with the bender **815**. They may, for example, be placed one either side of the bender, but are in any case arranged such that one sensing layer experiences compression whilst the other experiences extension, and vice versa, of approximately equal magnitudes. In such an arrangement, both piezo-resistive sensing layers will experience very similar magnitude strains (but of opposite signs) during operation of the bender, and both will be subject to similar temperature variations due both to environmental temperature changes and to changes in bender temperature caused for example by the drive power applied to it. In the circuit of **FIG. 8** they are then connected such that their resistance changes provide feedback voltage of opposite polarities to the two separate input terminals of the amplifier **816**. In this way their sensing signals add together to provide increased negative feedback. However, any changes in their resistance—due to common temperature variations, or due to long term ageing of the material—will tend to balance, and so produce approximately zero feedback voltage. In this way a highly temperature compensated integrated actuator/sensor and control circuit may be achieved.

[0044] In a further slight variation on the last described circuit and device configuration, the resistors **813, 812** (and not **814**) are both piezo-resistive layers, and may be bonded on to the one and same side of the bender, each occupying roughly half the width of the bender and each running the full length of the bender and thus experiencing essentially the whole bender strain, but being electrically isolated from one another. In this configuration, strain in the bender **815** results in similar magnitude and sign of piezo-resistive changes in the two sensing resistors **813,812**. Their location in the circuit of **FIG. 3** results in their strain-related resistance signals being additive, and causing negative feedback.

[0045] **FIGS. 4A, 4B** show simple bimorph “benders” with a piezoelectric sensing layer.

[0046] **FIG. 4B** shows a simple bimorph bender of conventional type, wherein two layers of piezoelectric material **61,62** are bonded together, with an optional electrode **64** between them, and electrodes **65,66** attached such that a drive voltage may be applied to the opposing faces of the structure so formed. An additional layer **63** of piezoelectric material is the sensor layer; it plays no part in the bender deflection process when layers **61,62** are driven (other than to impede it somewhat by virtue of its finite compliance). An

additional electrode **67** is arranged on that face of sensor layer **63** not bonded to layer **62**, in order to provide a signal output from this sensor layer when deflected by the bender action of layers **61,62**.

[0047] In the device as shown, the sensing layer **63** shares a common electrode **66** with the two main layers **61,62**. In applications where this electrode sharing is undesirable, it is possible to replace the single electrode **66** with a pair of electrodes insulated from each other by a thin intervening layer, one of which provides connection to the bender proper layer **62** and one of which provides connection only to the sensing layer **63**. However, it will often be adequate to use electrode **66** as a common ground for driving and sensing connections with little interference then generated in the sensing circuit by the driving circuit, provided care is taken to ensure that electrode **66** is adequately conductive.

[0048] In **FIG. 4A** there is shown a helical bender much like that of **FIG. 1**, with two electrically-driven piezoelectric layers **609, 610** (the electrodes are not shown), but with the addition of a further piezoelectric laminate layer **608**. This additional layer plays no active role in deflecting the structure, but is used instead to provide a feedback signal to sensing electronics (not shown) about the actual deflection of the bender when in use. The added “passive” sensor layer **608** also has surface electrodes (not shown), one of which may be shared with the active layer **609** if desired, as described above for the simple bender case.

[0049] In use, a voltage is driven between the top (as viewed) of active layer **609** and the bottom of active layer **610**, which layers have been previously poled in an opposite sense to each other. This causes the ribbon-like structure (which has been edge-, or flat-, wound into a helix) to bend, and this deflection causes the helix as a whole to lengthen or shorten depending on the sign of the drive voltage. The sensing layer **608**, being securely bonded to (or fired onto) active layer **609** is also deflected by this bender activity, and in so being, and because it is itself piezoelectric, produces a voltage signal between its surfaces which may be used as a feed back signal connected via its surface electrodes (not shown).

We claim:

1. A bender structure piezoelectric device having an additional laminate layer of a piezo-resistive material the function of which is for sensing and responding to the actual deflection of the bender device.
2. A piezoelectric device as claimed in claim 1, wherein in operation an associated control system applies a voltage and detects the change in current and thus resistance, or applies a current and detects the change in voltage.
3. A piezoelectric device as claimed in claim 1, wherein said additional laminate layer is arranged to be the layer closest to the neutral axis of the bender, generally near the centre of the bender layer-stack.
4. A piezoelectric device as claimed in claim 1, wherein there are two or more said additional laminate layers, disposed in such a manner as to minimise hysteresis effects therein by arranging for some cancellation of the hysteresis effects between the layers when used in combination.
5. A piezoelectric device as claimed in claim 4, wherein there is included a differential amplifier used in operation to sense the difference of the output signals from the two or

more said additional laminate layers and to provide a net signal therefrom that more precisely indicates the actual deflection of the bender.

6. A piezoelectric device as claimed in claim 4, wherein the two or more said additional laminate layers are each arranged to sense in use the strain in the bender, whereafter, by suitable electronic techniques, their deflection sensitive signals may be made to add, while their temperature dependent and other non-strain-related resistance changes may be made largely to cancel.

7. A piezoelectric device as claimed in claim 1, wherein piezoelectric device comprises several layers of piezoelectric material bonded together into a laminate with said additional laminate layer also bonded into the laminate.

8. A piezoelectric device as claimed in claim 1, wherein, in order to achieve better linearity of the piezoresistive sensing layer around the zero strain point of the bender, said additional laminate layer is bonded to the piezoelectric device, in the post-sintering method of construction, the piezoelectric device is maximally deflected in the direction that would normally apply compressive strain to the piezoresistive layer, and the bender deflection maintained until the bonding process is complete.

9. An acoustic transducer incorporating a piezoelectric device as claimed in claim 1, wherein the piezoelectric device is arranged to produce movement of air, and thus sound waves, in response to an input drive voltage.

* * * * *