

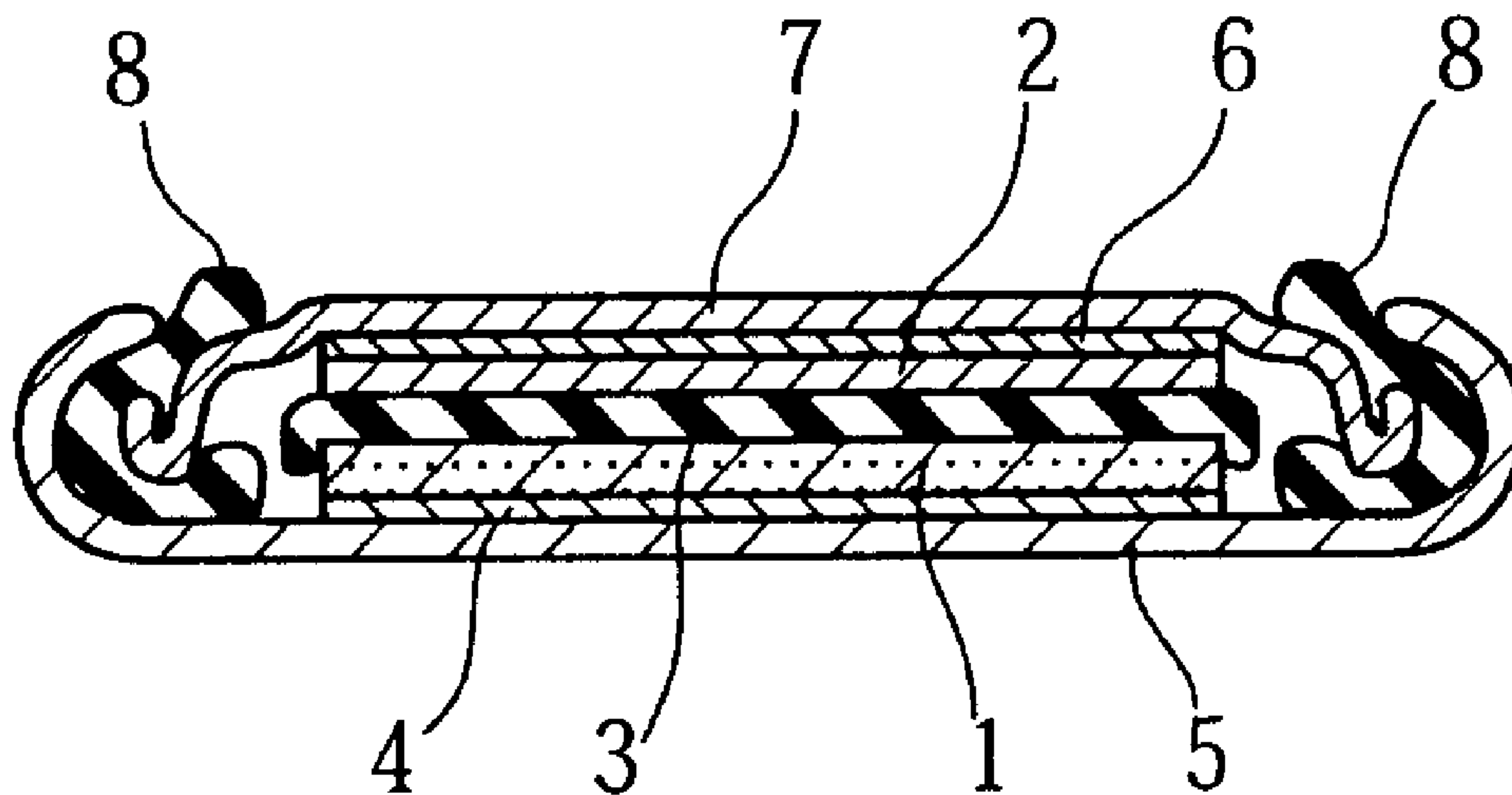

(22) Date de dépôt/Filing Date: 1998/07/14
 (41) Mise à la disp. pub./Open to Public Insp.: 1999/08/16
 (45) Date de délivrance/Issue Date: 2002/12/24
 (30) Priorité/Priority: 1998/02/16 (10-033014) JP

(51) Cl.Int.⁶/Int.Cl.⁶ H01M 10/24, H01M 4/24
 (72) Inventeurs/Inventors:
 TSUTSUMI, MASAMI, JP;
 HORIUCHI, HIROSHI, JP;
 YAMAMOTO, TAMOTSU, JP;
 WATANABE, ISAO, JP;
 MIYASHITA, TSUTOMU, JP
 (73) Propriétaire/Owner:
 FUJITSU LIMITED, JP
 (74) Agent: FETHERSTONHAUGH & CO.

(54) Titre : PILE SECONDAIRE AU LITHIUM ET COMPOSITION DE LA CATHODE ENTRANT DANS LA FABRICATION DE CE TYPE DE PILE
 (54) Title: LITHIUM SECONDARY BATTERY AND CATHODE COMPOSITION THEREFOR



(57) Abrégé/Abstract:

A lithium secondary battery includes a cathode which can be dischargeably charged with lithium ions, an anode made of lithium metal, a lithium alloy or any other anode material which can be releasably doped with lithium ions, an electrolyte which allows migration of lithium ions between both electrodes, and an endothermic substance which undergoes an endothermic reaction upon a temperature rise of the battery for preventing excessive heat generation. Typically, the endothermic substance is a metal carbonate such as magnesium carbonate, cobalt (II) carbonate, silver carbonate, cadmium carbonate or sodium hydrogencarbonate.

5

ABSTRACT OF THE DISCLOSURE

A lithium secondary battery includes a cathode which can be dischargeably charged with lithium ions, an anode made of lithium metal, a lithium alloy or any other anode material which can be releasably doped with lithium ions, an electrolyte which allows migration of lithium ions between both electrodes, and an endothermic substance which undergoes an endothermic reaction upon a temperature rise of the battery for preventing excessive heat generation. Typically, the endothermic substance is a metal carbonate such as magnesium carbonate, cobalt (II) carbonate, silver carbonate, cadmium carbonate or sodium hydrogencarbonate.

TITLE OF THE INVENTION

LITHIUM SECONDARY BATTERY AND CATHODE COMPOSITION THEREFOR

BACKGROUND OF THE INVENTION

5 1. Field of the Invention:

The present invention relates to a lithium secondary battery which may be used as a power source for retaining data in a memory of an electronic apparatus (e.g., a personal computer) or for driving a portable electronic apparatus (e.g., a portable telephone receiver).

10 The present invention also relates to a cathode composition used for such a battery.

2. Description of the Related Art:

As is well known, a lithium secondary battery comprises a cathode dischargeably charged with lithium ions, an anode and an electrolyte
15 which allows migration of lithium ions between both electrodes. The anode may consist of lithium metal, a lithium alloy or any other material which can be releasably doped with lithium ions. Typically, the electrolyte may be a nonaqueous electrolytic solution which is prepared by dissolving a lithium salt in an organic solvent.

20 Due to the high energy density and the use of an organic solvent, a lithium secondary battery is known to have a problem of generating a large amount of heat under severe conditions. For example, the lithium battery generates heat at the time of compression (e.g., battery crushing under a heavy object), nail piercing (e.g., when erroneously
25 driving a nail into the battery at the time of packaging), internal shorting, exposure to high temperature, or external shorting.

One way to solve such a problem is to provide a porous separator

between the cathode and the anode, as disclosed in JP-A-54(1979)-52157 or JP-A-59(1984)-207230 for example. According to this solution, the pores of the separator are closed at the melting point of the separator material due to the fusion thereof, thereby interrupting the ion migration between the cathode and the anode. As a result, the current flow terminates to stop the temperature rise.

As an improvement to a lithium secondary battery incorporating a porous separator, JP-A-5(1993)-74443 discloses an arrangement wherein the separator has an excess portion projecting beyond the edge faces of the cathode and the anode, and wherein the excess portion of the separator is pressed down against the edge faces of both electrodes by an insulating plate which is thermally fusible to the separator. Such an arrangement prevents excess heat generation or thermal runaway which may occur through shorting between the cathode and the anode due to a shrinkage of the separator near the edge faces of both electrodes after the pores of the separator are thermally closed.

However, the prior art lithium secondary battery incorporating the porous separator operates properly for the prevention of excessive heat generation only when the separator is kept in its appropriate state. Therefore, the battery is incapable of preventing excessive heat generation if the cathode comes into direct contact with the anode upon rupture of the separator under crushing of the battery or if both electrodes are shorted via a nail which has penetrated through the separator. It should be noted that excessive heat generation in a lithium secondary battery occurs because the Joule heat generated at the time of shorting causes oxygen to separate from the cathode active substance for reacting with active lithium.

On the other hand, JP-A-7(1995)-78635 proposes the use, in a lithium secondary battery, of an electrolytic solution which contains LiAsF₆/1,3-dioxolane + tertiary amine. Normally, the tertiary amine prevents polymerization of 1,3-dioxolane. Conversely, when the temperature of the battery rises due to high-temperature exposure or shorting for example, 1,3-dioxolane starts polymerizing to increase the internal resistance of the battery, whereby the current flow decreases and the temperature of the battery drops.

However, the above-described electrolytic solution contains As in LiAsF₆. Therefore, sufficient care needs to be taken in handling the battery for preventing environmental pollution. Further, the electrolytic solution is known to decompose when the battery voltage increases to no less than 4V, so that the candidate materials for the cathode active substance are limited to those which make the charge terminating voltage of the battery below 4V. This is critically disadvantageous in increasing the energy density of the battery.

SUMMARY OF THE INVENTION

It is, therefore, an object of the present invention is to provide a lithium secondary battery which is capable of reliably preventing excessive heat generation even under severe conditions such as battery
5 crushing, nail piercing, internal shorting, high-temperature exposure or external shorting without entailing the problems of the prior art lithium batteries described above.

Another object of the present invention is to provide a cathode composition which can be advantageously used for such a battery.

10 According to a first aspect of the present invention, there is provided a lithium secondary battery which comprises a cathode which can be dischargeably charged with lithium ions; an anode selected from a group including lithium metal, a lithium alloy and any other anode material which can be releasably doped with lithium ions; an electrolyte
15 which allows migration of lithium ions between both electrodes; and an endothermic substance which undergoes an endothermic reaction upon a temperature rise of the battery for preventing excessive heat generation.

According to a preferred embodiment of the present invention, the
20 endothermic substance comprises at least one metal carbonate which thermally decomposes upon a temperature rise of the battery. Examples of metal carbonate include magnesium carbonate, cobalt(II) carbonate, silver carbonate, cadmium carbonate and sodium hydrogencarbonate which are usable alone or in combination.

25 Of the above-enumerated metal carbonates, magnesium carbonate thermally decomposes according to the following reaction (1) when the battery undergoes crushing, nail piercing, internal shorting, high-

temperature exposure or external shorting.



Cobalt carbonate thermally decomposes according to the following
5 reaction (2).



Silver carbonate thermally decomposes according to the following
10 reaction (3).



Cadmium carbonate thermally decomposes according to the following
reaction (4).

15



Sodium hydrogencarbonate thermally decomposes according to the
following reaction (5).

20

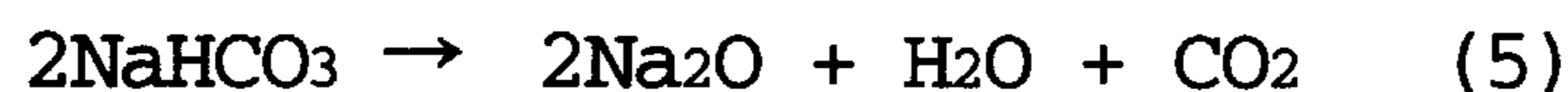

All of the above reactions are endothermic, which becomes clear by
referring to the enthalpy change from the reactant and the products.
25 In the reaction (1), for instance, the standard enthalpy of formation
of magnesium carbonate (enthalpy of formation at standard state) is
about -1,130kJ/mol and the standard enthalpy of formation of magnesium

oxide is about -600kJ/mol, whereas the standard enthalpy of formation of carbon dioxide is about 400kJ/mol. Thus, the enthalpy change from the reactant to the products is about +130kJ/mol, which means that the reactant needs 130kJ/mol for decomposition. This calculation is made
5 on the assumption that the reaction occurs under standard state. In reality, the thermal decomposition occurs with a temperature rise, so that the actual enthalpy change deviates somewhat from the above calculation. However, there is no doubt that the above decomposition is endothermic. Further, the inventors have confirmed through the
10 differential scanning calorimetry that each of the above thermal decomposition reactions is endothermic, as hereinafter described.

In summary, the metal carbonate as the endothermic substance prevents excessive heat generation of the lithium secondary battery due to the following two functions. First, the endothermic nature, in
15 thermal decomposition, of the metal carbonate directly prevents excessive heat generation of the battery. Secondly, since the thermal decomposition of the metal carbonate is accompanied by generation of carbon dioxide which provides a reluctantly oxidizing atmosphere, lithium from the anode reluctantly reacts with oxygen which would be
20 liberated from the cathode active substance upon a temperature rise of the battery, thereby preventing excessive heat generation of the battery in an indirect way. In this regard, the inventors have experimentally confirmed that the metal carbonate does not hinder the cell reaction in the lithium secondary battery.

25 The endothermic substance (e.g., metal carbonate) may be contained in the cathode. Generally, the cathode comprises a composition which contains a cathode active substance for releasably occluding lithium

ions, an electrically conductive agent for enhancing the electric conductivity of the cathode, and a binder for binding the cathode active substance and the conductive agent together. Therefore, metal carbonate powder as the endothermic substance may be contained in the cathode composition by utilizing the adhesion of the binder.

10 The proportion of the added metal carbonate in the cathode composition preferably lies in the range of 0.1 - 20 wt%, preferably 2 - 20 wt%. A proportion below 0.1 wt% results in insufficiency of preventing excessive heat generation of the battery. A proportion beyond 20 wt% results in a decrease of the battery capacity while reaching the ceiling (upper limit) in preventing excessive heat generation of the battery.

20 Examples of the cathode active substance include lithium - transition metal oxides and transition metal oxides such as LiCoO_2 , LiNiO_2 , LiMnO_2 , LiMn_2O_4 and V_2O_5 . However, the present invention is not limited to these examples. The cathode active substance is preferably used in an amount of 50 - 95 wt% of the cathode composition.

Examples of the electrically conductive agent include electrically conductive carbonaceous materials such as acetylene black and graphite. However, these examples are not limitative, and other conductive agents used for the cathode composition of a known lithium secondary battery are also usable for the battery of the present invention. The electrically conductive material is preferably used in an amount of 1 - 15 wt% of the cathode composition.

Examples of the binder include thermoplastic resins, especially fluorine-containing resins such as poly(vinylidene fluoride) (PVDF) and polytetrafluoroethylene (e.g. known under the trade-mark "Teflon") and ethylene-propylenediene ternary copolymer (EPDM). The binder is preferably used in an amount of 1 to 15 wt% of the cathode composition.

10 On the other hand, the endothermic substance may be alternatively or additionally contained in the anode. In this case, metal carbonate powder as the endothermic substance is mixed with a suitable binder (which is similar to the binder of the cathode composition), and the resulting mixture may be applied to a surface of a lithium foil, a lithium

plate or a lithium alloy plate (e.g., lithium-aluminum alloy, lithium-tin alloy or lithium-lead alloy).

Further, the endothermic substance may be contained in the electrolyte. For instance, metal carbonate powder as the endothermic substance may be contained in a solid electrolyte such as polyethylene oxide (PEO).

The electrolyte may comprise a nonaqueous electrolytic solution which is prepared by dissolving a lithium-ion-conductive solute in an organic solvent. Examples of lithium-ion-conductive solute include LiPF_6 (lithium hexafluorophosphate) and LiBF_4 (lithium tetraborate), LiClO_4 (lithium perchlorate). Examples of organic solvent include propylene carbonate (PC), tetrahydrofuran (THF), ethylene carbonate (EC), 1,2-dimethoxyethane (DME), diethyl carbonate (DEC), 2-methyl-tetrahydrofuran (2-MeTHF) and dimethyl carbonate (DMC). In this regard, it should be noted that since metal carbonate as the endothermic substance is not soluble in the organic solvent, the metal carbonate needs to be contained in the cathode and/or the anode.

According to a second aspect of the present invention, there is provided a cathode composition for a lithium secondary battery containing a cathode active substance which can be dischargeably charged with lithium ions, an electrically conductive agent, a binder, and an endothermic substance which undergoes an endothermic reaction upon a temperature rise. As previously described, the endothermic substance may comprise a metal carbonate which is selected from a group including magnesium carbonate, cobalt(II) carbonate, silver carbonate, cadmium carbonate and sodium hydrogencarbonate.

The present invention will be apparent from the detailed

description of the preferred embodiments given below with reference to the accompanying drawings.

BRIEF DESCRIPTION OF THE DRAWINGS

In the accompanying drawings:

Fig. 1 is a sectional view showing a typical example of coin-type lithium secondary battery to which the present invention may be applied;

5 Fig. 2 is a sectional view showing a typical example of cylindrical lithium secondary battery to which the present invention may be applied;

Fig. 3 is a fragmentary perspective view showing a laminate of cathode-anode-separator, partially exploded, which is incorporated in the cylindrical lithium secondary battery shown in Fig. 2;

10 Fig. 4 is a graph showing the endothermic characteristics obtained by the differential scanning calorimetry of magnesium carbonate;

Fig. 5 is a graph showing the endothermic characteristics obtained by the differential scanning calorimetry of cobalt (II) carbonate;

15 Fig. 6 is a graph showing the endothermic characteristics obtained by the differential scanning calorimetry of silver carbonate;

Fig. 7 is a graph showing the endothermic characteristics obtained by the differential scanning calorimetry of cadmium carbonate; and

Fig. 8 is a graph showing the endothermic characteristics obtained by the differential scanning calorimetry of sodium hydrogencarbonate.

DETAILED DESCRIPTION OF THE PREFERRED EMBODIMENTS

The preferred embodiments of the present invention will be described below with reference to the accompanying drawings.

Figs. 1 and 2 of the accompanying drawings illustrate two typical examples of lithium secondary battery to which the present invention may be advantageously applied. Of these figures, Fig. 1 shows a coin-type battery, whereas Fig. 2 represents a cylindrical battery.

Referring first to Fig. 1, the coin-type lithium secondary battery includes a cathode 1 which contains LiCoO_2 as an active substance for example, an anode 2 made of e.g. a lithium foil, and a separator 3 made of e.g. a porous polypropylene or polyethylene film and interposed between the cathode 1 and the anode 2. The cathode 1 is formed on a cathode current collector 4 which is made of e.g. aluminum, and the cathode current collector 4 is attached on an inner surface of a cathode terminal 5 made of e.g. stainless steel. Similarly, the anode is formed on an anode current collector 6 which is made of e.g. aluminum, and the anode current collector 6 is attached on an inner surface of an anode terminal 7 made of e.g. stainless steel. The cathode terminal 5 and the anode terminal 7 form a container which is packed with a nonaqueous electrolytic solution prepared for example by dissolving LiPF_6 in an organic solvent mixture of ethylene carbonate (EC) and dimethyl carbonate (DMC). An annular packing 8 made of e.g. polypropylene is interposed between the cathode terminal 5 and the anode terminal 7 at the peripheral portions thereof to seal the container. In accordance with the present invention, the cathode 1 contains a metal carbonate (e.g. magnesium carbonate) as an endothermic substance.

Similarly, the cylindrical lithium secondary battery illustrated

in Fig. 2 also includes a cathode 1' which contains LiCoO_2 as an active substance for example, an anode 2' made of e.g. a lithium foil, and a separator 3' made of e.g. a porous polypropylene or polyethylene film and interposed between the cathode 1' and the anode 2'. The laminate
5 of the cathode 1', the anode 2' and the separator 3', which is originally a long strip of such a laminate (see Fig. 3), is helically wound around a center pin 9' and accommodated in a cylindrical anode terminal container 7' which may be made of e.g. stainless steel. Though not clear from Figs. 2 and 3, the cathode 1' is prepared by applying a cathode
10 composition on both surfaces of e.g. an aluminum foil as a cathode collector and rolling the cathode composition, whereas the anode 2' includes lithium foils (as an anode active substance) attached on both surfaces of e.g. a copper foil as an anode collector. In accordance with the present invention, the cathode 1' contains a metal carbonate
15 (e.g. magnesium carbonate) as an endothermic substance.

The anode 2' is provided with an anode lead tab 10' which extends beyond a lower insulating plate 11' into contact with an inner bottom surface of the anode terminal container 7'. The cathode 1' is held in
20 conduction with a cathode lead tab 12' which extends through an upper insulating plate 13' into electrical conduction with a cathode terminal lid 5' via a cathode lead pin 14'. The space formed by the combination of the cathode terminal lid 5' and the anode terminal container 7' is packed with a nonaqueous electrolytic solution prepared for example by
25 dissolving LiPF_6 in an organic solvent mixture of ethylene carbonate (EC) and dimethyl carbonate (DMC). An annular packing 8' made of e.g. polypropylene is interposed between the cathode terminal lid 5' and the anode terminal container 7' for sealing purposes.

25307-316

Next, examples of the present invention together with comparative examples will be specifically described.

[Example 1]

In Example 1, a plurality of cylindrical lithium secondary
5 batteries each having the structure shown in Fig. 3 were manufactured
by incorporating a cathode, an anode, a separator and a nonaqueous
electrolytic solution, as specified below. Each of the batteries,
which had a diameter of 14mm and a length of 50mm, was subjected to a
crushing test. In addition, the metal carbonate contained as an
10 endothermic substance was subjected to the differential scanning
calorimetry for confirmation of its endothermic effect.

Cathode:

For making a cathode composition, a uniform mixture was prepared
which contained 81wt% of LiCoCO_2 as a cathode active substance, 2.5wt%
15 of acetylene black plus 2.5wt% of graphite as electrically conductive
agents, 9wt% of magnesium carbonate as an endothermic substance, and
5wt% of poly(vinylidene fluoride) (PVDF) as a binder. The cathode
composition thus obtained was applied to both surfaces of an aluminum
foil as a cathode collector and rolled, thereby providing a cathode 1'.

20 Anode:

For providing an anode 2', a copper foil as an anode collector was
sandwiched between lithium foils as an anode active substance.

Separator:

A porous polyethylene film was used as a separator 3'.

25 Electrolytic Solution:

LiPF_6 (lithium hexafluorophosphate) was dissolved in a 1:2 solvent
mixture of ethylene carbonate (EC) and dimethyl carbonate (DMC) for

preparing an electrolytic solution having a concentration of 1mol/dm^3 .

Crushing Test:

Seven (7) samples of lithium secondary batteries were manufactured using the above-described elements, and each of the samples was subjected to a crushing test. In the crushing test, a presser rod (substantially square in cross section) pressed diametrically against a lengthwise center portion of the battery which had been charged up to a voltage of 4.2V for crushing the battery (center portion) to half of the original battery diameter. The results of the crushing test are shown in Table 1 where the notation "NGs" represents the number of samples which ignited due to excessive heat generation.

TABLE 1

Results of Crushing Test

Identification of Batteries	NGs/Samples (Percentage)
Example 1	0/7 (0%)
Example 2	0/6 (0%)
Example 3	0/8 (0%)
Example 4	0/7 (0%)
Example 5	0/6 (0%)
Comparative Example	10/10 (100%)

Confirmation Test for Endothermic Effect:

In addition to the above-described crushing test, the magnesium carbonate contained in the cathode composition was subjected to the differential scanning calorimetry for confirmation of its endothermic

effect. More specifically, the magnesium carbonate was thermally decomposed by heating at a speed of 10°C/min from 25°C to 500°C with a differential scanning calorimeter (DSC-100 available from Seiko Electronic Industries Co. Ltd., Japan). The results of the differential scanning calorimetry are shown in Fig. 4. With regard to Fig. 4 (and Figs. 5~8 as well), the minus (-) sign indicates the absorption of heat, whereas the area of the regions encircled by the heat variation curve and the broken lines represents the integral of heat (i.e., total heat) absorbed by the metal carbonate.

10 [Example 2]

In Example 2, six (6) samples of cylindrical lithium secondary batteries identical to those of Example 1 except for the use of cobalt (II) carbonate as an endothermic substance were manufactured. Each of the samples was subjected to a crushing test. In addition, the cobalt (II) carbonate used in this example was subjected to the differential scanning calorimetry for confirmation of its endothermic effect. The results of both tests are shown in Table 1 and Fig. 5, respectively.

[Example 3]

In Example 3, eight (8) samples of cylindrical lithium secondary batteries identical to those of Example 1 except for the use of silver carbonate as an endothermic substance were manufactured. Each of the samples was subjected to a crushing test. In addition, the silver carbonate used in this example was subjected to the differential scanning calorimetry for confirmation of its endothermic effect. The results of both tests are shown in Table 1 and Fig. 6, respectively.

[Example 4]

In Example 4, seven (7) samples of cylindrical lithium secondary

25307-316

batteries identical to those of Example 1 except for the use of cadmium carbonate as an endothermic substance were manufactured. Each of the samples was subjected to a crushing test. In addition, the cadmium carbonate used in this example was subjected to the differential scanning calorimetry for confirmation of its endothermic effect. The results of both tests are shown in Table 1 and Fig. 7, respectively.

[Example 5]

In Example 5, six (6) samples of cylindrical lithium secondary batteries identical to those of Example 1 except for the use of sodium hydrogencarbonate as an endothermic substance were manufactured. Each of the samples was subjected to a crushing test. In addition, the sodium hydrogencarbonate used in this example was subjected to the differential scanning calorimetry for confirmation of its endothermic effect. The results of both tests are shown in Table 1 and Fig. 8, respectively.

[Comparative Example]

For comparison, ten (10) samples of cylindrical lithium secondary batteries identical to those of Example 1 except for the use of a different cathode composition were manufactured. The cathode composition used in this comparative example is a uniform mixture containing 90wt% of LiCoCO_2 as a cathode active substance, 2.5wt% of acetylene black plus 2.5wt% of graphite as electrically conductive agents, and 5wt% of poly(vinylidene fluoride) (PVDF) as a binder. Each of the samples was subjected to a crushing test. The results of the crushing test are shown in Table 1.

[Evaluation]

As noted from Table 1, all of the battery samples made in Examples 1-5 did not experience excessive heat generation nor ignition in the

crushing test. This fact clearly indicates that the endothermic substance (i.e., each of the different metal carbonates added to the cathode composition in each of Examples 1~5) contained in the battery fulfilled its endothermic function for effectively preventing excessive heat generation of the battery. By contrast, the battery samples of Comparative Example containing no endothermic substance equally suffered ignition in the crushing test due to excessive heat generation.

Further, as understood from Figs. 4~8, the metal carbonate used in each of Examples 1~5 exhibited one or two heat absorption peaks at a temperature or temperatures below 500°C. This indicates that the prevention of excessive heat generation is attributable to the endothermic thermal decomposition of the metal carbonate.

Therefore, it is concluded that the lithium secondary battery according to the present invention is advantageous for its high safety even under severe conditions such as battery crushing, nail piercing, internal shorting, high-temperature exposure and/or external shorting.

The present invention being thus described, it is obvious that the same may be varied in many ways. Such variations should not be regarded as a departure from the spirit and scope of the present invention, and all such modifications as would be obvious to those skilled in the art are intended to be included within the scope of the following claims.

25307-316

CLAIMS:

1. A lithium secondary battery comprising:

 a cathode which can be dischargeably charged with lithium ions;

5 an anode selected from the group consisting of lithium metal, a lithium alloy and any other anode material which can be releasably doped with lithium ions;

 an electrolyte which allows migration of lithium ions between the cathode and the anode; and

10 an endothermic metal carbonate selected from the group consisting of cobalt (II) carbonate, silver carbonate, cadmium carbonate, sodium hydrogen carbonate, and mixtures thereof, wherein the endothermic metal carbonate thermally decomposes upon a temperature rise of the battery for

15 preventing excessive heat generation.
2. The lithium secondary battery according to claim 1, wherein the endothermic metal carbonate is cobalt (II) carbonate.
3. The lithium secondary battery according to
20 claim 1, wherein the endothermic metal carbonate is silver carbonate.
4. The lithium secondary battery according to claim 1, wherein the endothermic metal carbonate is cadmium carbonate.
- 25 5. The lithium secondary battery according to claim 1, wherein the endothermic metal carbonate is sodium hydrogen carbonate.

25307-316

6. The lithium secondary battery according to any one of claims 1 to 5, wherein the endothermic metal carbonate is contained in the cathode.

7. The lithium secondary battery according to any one of claims 1 to 5, wherein the endothermic metal carbonate is contained in the anode.

8. The lithium secondary battery according to any one of claims 1 to 7, wherein the electrolyte comprises a non-aqueous electrolytic solution which is prepared by dissolving a lithium-ion-conductive solute in an organic solvent.

9. The lithium secondary battery according to claim 8, wherein the lithium-ion-conductive solute is selected from a group including LiPF_6 , LiBF_4 and LiClO_4 .

10. The lithium secondary battery according to claim 8 or 9, wherein the organic solvent is selected from a group including propylene carbonate, tetrahydrofuran, ethylene carbonate, 1,2-dimethoxyethane, diethyl carbonate, 2-methyl-tetrahydrofuran and dimethyl carbonate.

11. A cathode composition for a lithium secondary battery, the cathode composition containing:

a cathode active substance which can be dischargeably charged with lithium ions,

an electrically conductive agent,

a binder, and

an endothermic metal carbonate selected from the group consisting of cobalt (II) carbonate, silver carbonate, cadmium carbonate, sodium hydrogen carbonate, and mixtures

25307-316

thereof, wherein the endothermic metal carbonate thermally decomposes upon a temperature rise.

12. The cathode composition according to claim 11, wherein the endothermic metal carbonate is cobalt (II) carbonate.
5
13. The cathode composition according to claim 11, wherein the endothermic metal carbonate is silver carbonate.
14. The cathode composition according to claim 11, wherein the endothermic metal carbonate is cadmium carbonate.
10
15. The cathode composition according to claim 11, wherein the endothermic metal carbonate is sodium hydrogen carbonate.
16. The cathode composition according to any one of claims 11 to 15, wherein the metal carbonate is contained in an amount of 0.1-20 wt% of the cathode composition.
15
17. The cathode composition according to any one of claims 11 to 16, wherein the cathode active substance is selected from the group consisting of LiCoO_2 , LiNiO_2 , LiMnO_2 , LiMn_2O_4 and V_2O_5 .
20
18. The cathode composition according to any one of claims 11 to 17, wherein the electrically conductive agent is selected from the group consisting of acetylene black and graphite.
- 25 19. The cathode composition according to any one of claims 11 to 18, wherein the binder is selected from the group consisting of poly(vinylidene fluoride),

25307-316

polytetrafluoroethylene and ethylene-propylene-diene ternary copolymer.

20. The lithium secondary battery according to any one of claims 1 to 5, wherein:

5 the cathode is composed essentially of a cathode active substance for releasably occluding lithium ions, an electrically conductive agent and a binder;

the electrolyte is a non-aqueous electrolytic organic solution of a lithium salt dissolved in an organic
10 solvent or polyethylene oxide; and

the endothermic metal carbonate is contained (1) in the cathode, (2) in a mixture thereof with a binder, the mixture being applied to a surface of a lithium foil, a lithium plate or a lithium alloy plate employed as the anode
15 or (3) in the electrolyte when the electrolyte is polyethylene oxide.

21. The lithium secondary battery according to claim 20, wherein the endothermic metal carbonate is cobalt (II) carbonate or silver carbonate and is contained (1) in the
20 cathode in an amount of 0.1 to 20 wt% based on the cathode.

22. A cathode for a lithium secondary battery comprising a cathode current collector and, applied thereon, a cathode composition consisting essentially of:

a cathode active substance that is a lithium-
25 transition metal oxide or V_2O_5 ,

an electrically conductive carbonaceous material,

a thermoplastic resin binder, and

25307-316

an endothermic metal carbonate selected from the group consisting of cobalt (II) carbonate, silver carbonate, cadmium carbonate and sodium hydrogen carbonate; which undergoes an endothermic decomposition upon a temperature
5 rise of the battery due to crushing, nail piercing, internal shorting, high temperature exposure or external shorting, in an amount of 0.1 - 20 wt% based on the cathode.

23. The lithium secondary battery according to claim 6, wherein the endothermic substance is mixed with a binder.

10 24. The lithium secondary battery according to any one of claims 1 to 5, wherein the electrolyte is solid polyethylene oxide.

25. The lithium secondary battery according to claim 24, wherein the endothermic metal carbonate is contained in
15 the solid electrolyte.

FETHERSTONHAUGH & CO.
OTTAWA, CANADA

PATENT AGENTS

FIG.1

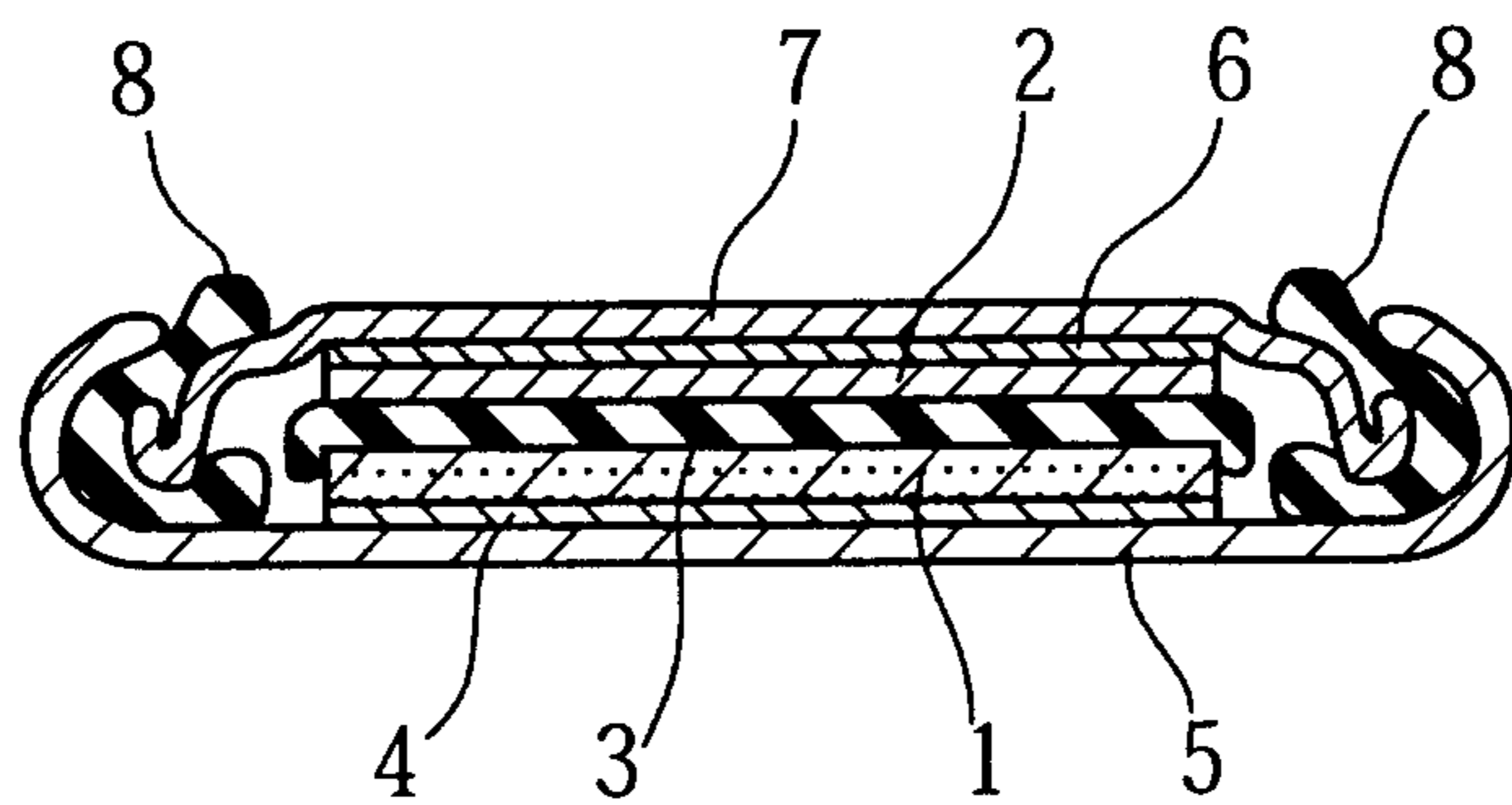

FIG.2

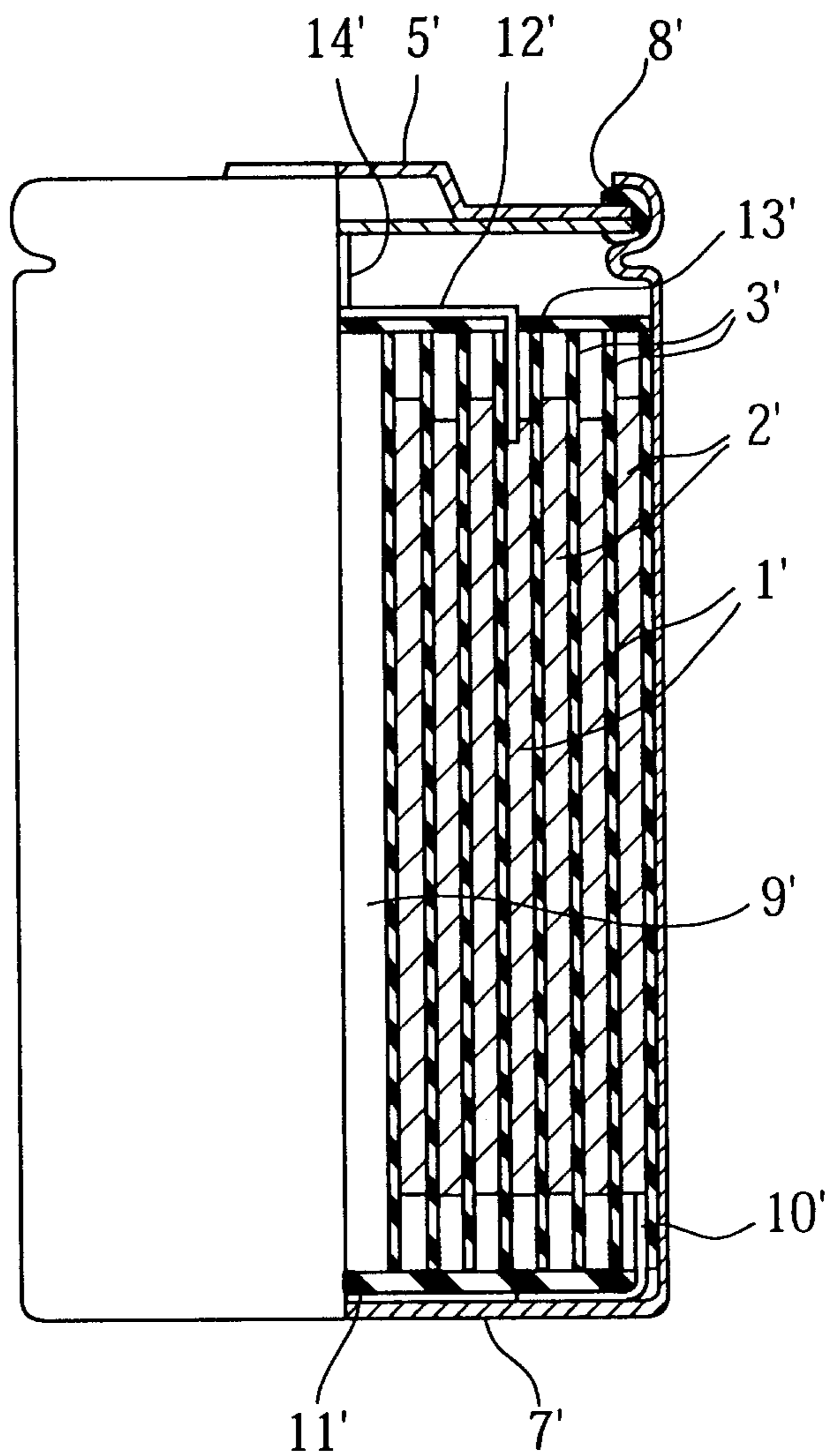
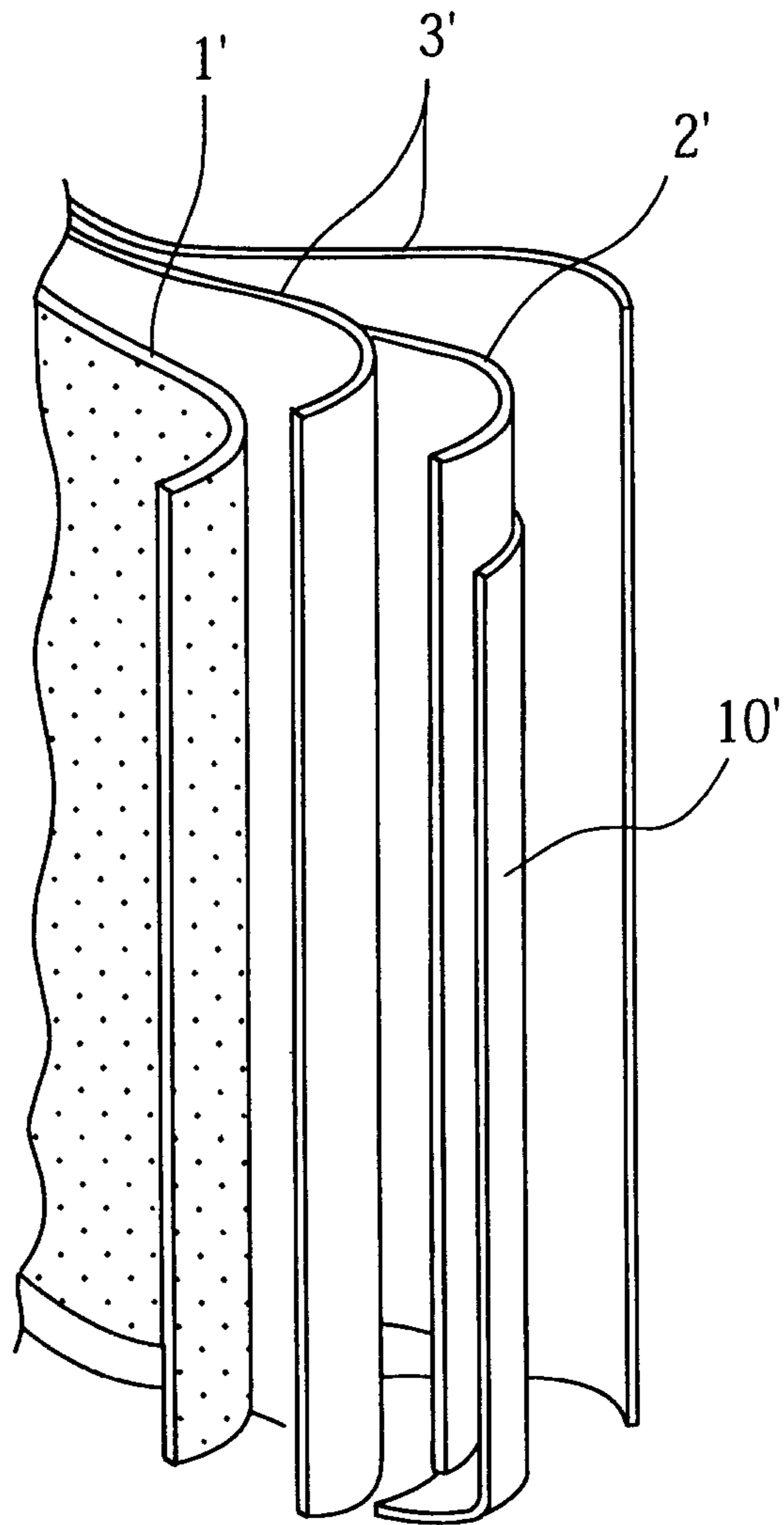

FIG.3



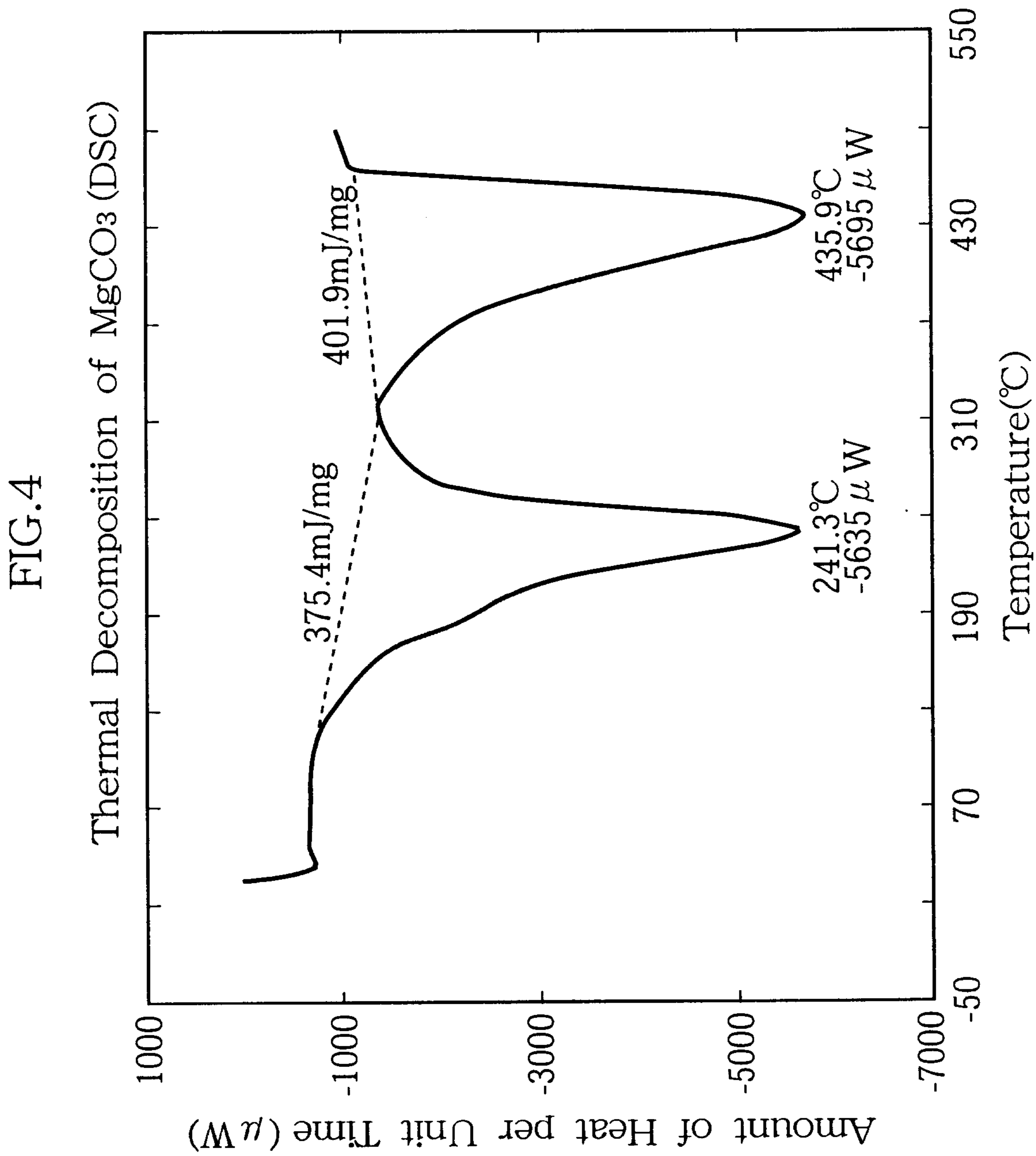

FIG.5
Thermal Decomposition of CoCO_3 (DSC)

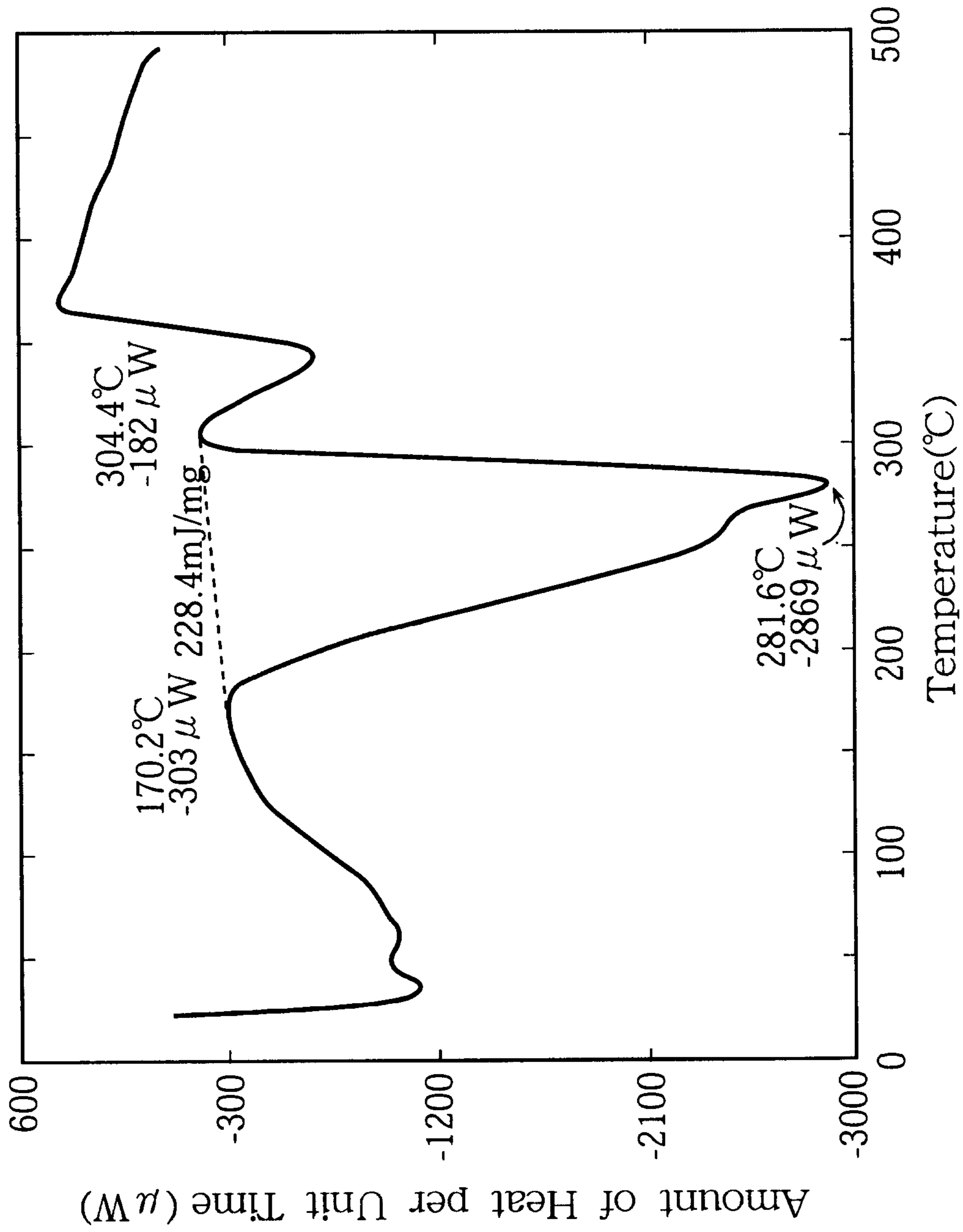

FIG.6
 Thermal Decomposition of Ag₂CO₃ (DSC)

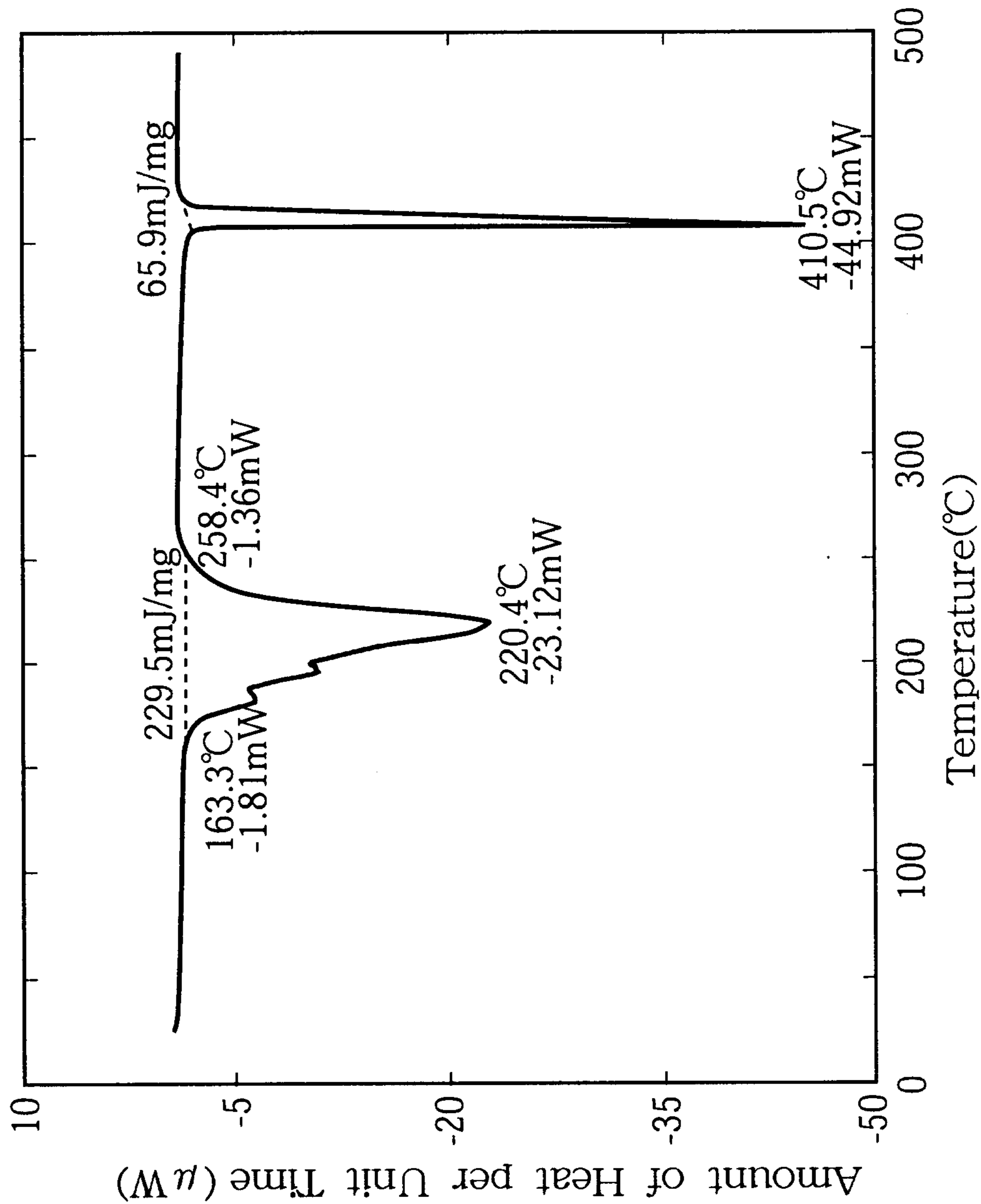

FIG. 7
 Thermal Decomposition of CdCO₃ (DSC)

