

(19) World Intellectual Property Organization
International Bureau



(43) International Publication Date
26 October 2006 (26.10.2006)

PCT

(10) International Publication Number
WO 2006/111883 A2

(51) International Patent Classification:
G01T 1/164 (2006.01)

(21) International Application Number:

PCT/IB2006/051089

(22) International Filing Date: 10 April 2006 (10.04.2006)

(25) Filing Language: English

(26) Publication Language: English

(30) Priority Data:

60/674,034 22 April 2005 (22.04.2005) US

60/682,246 18 May 2005 (18.05.2005) US

(71) Applicant (for all designated States except US): KONINKLIJKE PHILIPS ELECTRONICS, N.V. [NL/NL]; Groenewoudseweg 1, NL-5621 BA Eindhoven (NL).

(71) Applicant (for AE only): U.S. PHILIPS CORPORATION [US/US]; 1251 Avenue Of The Americas, New York, New York 10020 (US).

(72) Inventors; and

(75) Inventors/Applicants (for US only): FRACH, Thomas

[DE/DE]; Kullenhofstrasse 40a, 52074 Aachen (DE). FIEDLER, Klaus [DE/DE]; Turpinstrasse 111, 52066 Aachen (DE).

(74) Common Representative: KONINKLIJKE PHILIPS ELECTRONICS, N.V.; C/o Mcknight, Douglas, B. 595 Miner Road, Cleveland, Ohio 44143 (US).

(81) Designated States (unless otherwise indicated, for every kind of national protection available): AE, AG, AL, AM, AT, AU, AZ, BA, BB, BG, BR, BW, BY, BZ, CA, CH, CN, CO, CR, CU, CZ, DE, DK, DM, DZ, EC, EE, EG, ES, FI, GB, GD, GE, GH, GM, HR, HU, ID, IL, IN, IS, JP, KE, KG, KM, KN, KP, KR, KZ, LC, LK, LR, LS, LT, LU, LV, LY, MA, MD, MG, MK, MN, MW, MX, MZ, NA, NG, NI, NO, NZ, OM, PG, PH, PL, PT, RO, RU, SC, SD, SE, SG, SK, SL, SM, SY, TJ, TM, TN, TR, TT, TZ, UA, UG, US, UZ, VC, VN, YU, ZA, ZM, ZW.

(84) Designated States (unless otherwise indicated, for every kind of regional protection available): ARIPO (BW, GH, GM, KE, LS, MW, MZ, NA, SD, SL, SZ, TZ, UG, ZM, ZW), Eurasian (AM, AZ, BY, KG, KZ, MD, RU, TJ, TM),

[Continued on next page]

(54) Title: DIGITAL SILICON PHOTOMULTIPLIER FOR TOF-PET

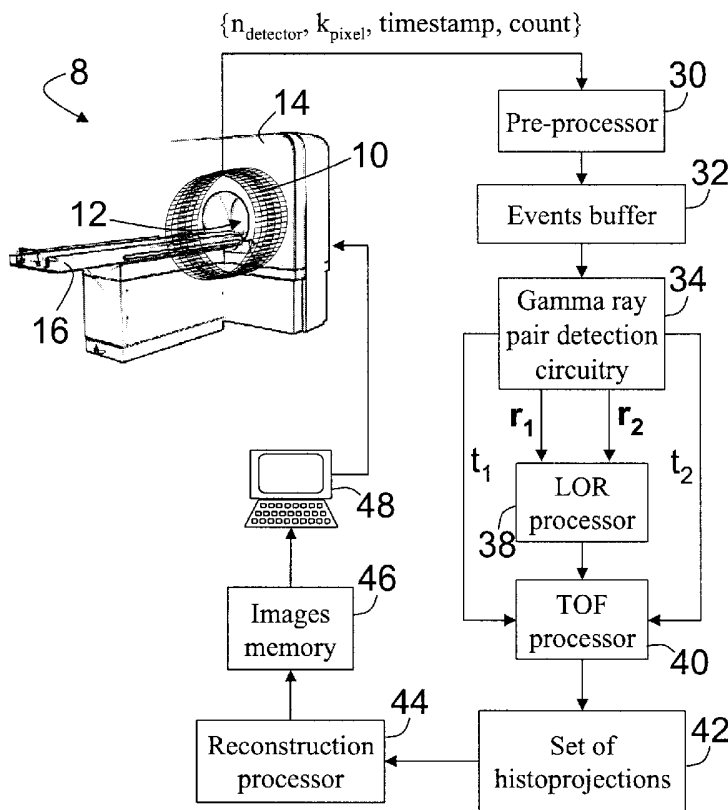

(57) Abstract: A radiation detector (10) includes an array of detector pixels (22) each including an array of detector cells (50, 50', 50''). Each detector cell includes a photodiode (52) biased in a breakdown region and digital circuitry (54, 54', 54'') coupled with the photodiode and configured to output a first digital value in a quiescent state and a second digital value responsive to photon detection by the photodiode. Digital triggering circuitry (60, 60', 60'') is configured to output a trigger signal indicative of a start of an integration time period responsive to a selected number of one or more of the detector cells transitioning from the first digital value to the second digital value. Readout digital circuitry (66, 82) accumulates a count of a number of transitions of detector cells of the array of detector cells from the first digital state to the second digital state over the integration time period.

WO 2006/111883 A2



European (AT, BE, BG, CH, CY, CZ, DE, DK, EE, ES, FI, FR, GB, GR, HU, IE, IS, IT, LT, LU, LV, MC, NL, PL, PT, RO, SE, SI, SK, TR), OAPI (BF, BJ, CF, CG, CI, CM, GA, GN, GQ, GW, ML, MR, NE, SN, TD, TG).

— *as to the applicant's entitlement to claim the priority of the earlier application (Rule 4.17(iii))*

Published:

— *without international search report and to be republished upon receipt of that report*

Declarations under Rule 4.17:

— *as to applicant's entitlement to apply for and be granted a patent (Rule 4.17(ii))*

For two-letter codes and other abbreviations, refer to the "Guidance Notes on Codes and Abbreviations" appearing at the beginning of each regular issue of the PCT Gazette.

DIGITAL SILICON PHOTOMULTIPLIER FOR TOF-PET

DESCRIPTION

The following relates to the radiation detection arts. It particularly relates to high-speed radiation detectors for positron emission tomography (PET), especially time-of-flight (TOF) PET, and will be described with particular reference thereto. However, the following relates more generally to radiation detectors for single photon emission computed tomography (SPECT), computed tomography (CT), and so forth, as well as to high-speed radiation detectors for other applications such as astronomy.

In conventional PET, a radiopharmaceutical is administered to a human patient or other imaging subject. The radiopharmaceutical produces radiation decay events that emit positrons, which travel a very short distance before rapidly interacting with an electron of the surrounding imaging subject in an electron-positron annihilation event to produce two oppositely directed gamma rays. The gamma rays are detected by radiation detectors surrounding the imaging subject as two substantially simultaneous radiation detection events that define a line of response (LOR) therebetween. Typically, the radiation detectors include scintillators that produce a burst or scintillation of light responsive to each gamma ray detection, and an array of photomultiplier tubes (PMT's) optically coupled with the scintillators that convert the light bursts into corresponding electrical signals. In some PET scanners, the PMT's are replaced by photodiodes that produce analog electrical currents proportional to the intensity of the light bursts.

Although the gamma rays are detected "substantially simultaneously", if one of the two involved radiation detectors is closer to the electron-positron annihilation event than the other radiation detector, then there will be a small time difference between the two radiation detection events. Since gamma rays travel at the speed of light, this time difference between detections is typically around a few nanoseconds or less. In TOF-PET, the radiation detectors operate at sufficiently high speed to enable measurement of this small time-of-flight difference, which is then used to localize the electron-positron annihilation event along the LOR.

Accordingly, for TOF-PET the radiation detectors should have sub-nanosecond temporal resolution. PMTs are generally fast enough to perform TOF-PET imaging; however, PMTs are bulky, require high voltage biasing, and are not well-suited for small

pixel sizes desirable for high resolution. Conventional photodiodes are fast enough for TOF-PET, but lack internal amplification, leading to poor signal-to-noise ratios. To get sufficient signal with a conventional photodiode, a charge-sensitive amplifier is typically employed to integrate the signal, which limits the bandwidth. Avalanche photodiodes can also be used; however, avalanche photodiodes typically suffer from high noise levels and high temperature and bias sensitivity in the gain.

To address these difficulties, silicon photomultiplier (SiPM) detectors have been proposed, for example in: E.A. Georgievskya et al., "The solid state silicon photomultiplier for a wide range of applications", 17th Int'l Conf. on Photoelectronics and Night Vision Devices, Proceedings of SPIE vol. 5126 (2003); Golovin et al., "Novel type of avalanche photodetector with Geiger mode operation", Nuclear Instruments & Methods in Physical Research A, volume 518, pages 560-64 (2004). These SiPM detectors use a pixelated array of small avalanche photodiodes biased in the breakdown region and interconnected in parallel. The output is the analog sum of the currents of parallel-interconnected avalanche photodiodes operating in limited Geiger-mode. Each detected photon in the SiPM detector adds on the order of 10^6 electrons to the output current of the SiPM. The Geiger discharge responsive to photon detection is fast, providing sharp rising edges of the signal that facilitate precise time measurements. Energy- and temporal-resolution scales with $1/\sqrt{N}$ where N is the number of firing cells.

The SiPM device has certain disadvantages. The analog current produced by a photon detection is affected by bias voltage, operating temperature, and critical circuit parameters such as the quenching resistance value. These factors can change the analog current produced by each photon detection, thus limiting the energy resolution of the SiPM. The analog configuration also has the disadvantages of producing high dark counts and allowing faulty avalanche photodiodes to substantially limit detector device manufacturing yield.

The following contemplates improved apparatuses and methods that overcome the aforementioned limitations and others.

According to one aspect, a detector pixel is disclosed for use in conjunction with a scintillator that converts a radiation particle to a burst of light. An array of detector cells is

provided. Each detector cell includes a photodiode biased in a breakdown region and digital circuitry coupled with the photodiode. The digital circuitry is configured to output a first digital value in a quiescent state and a second digital value responsive to detection of a photon by the photodiode. Digital triggering circuitry is configured to output a trigger signal indicative of a start of an integration time period responsive to a selected number of one or more of the detector cells transitioning from the first digital value to the second digital value. Readout digital circuitry accumulates a count of a number of transitions of detector cells of the array of detector cells from the first digital state to the second digital state over the integration time period.

10 In some embodiments, digital timestamp circuitry is configured to output a digital timestamp associated with the count. The digital timestamp is based on a time of the trigger signal relative to a time reference signal.

According to another aspect, a radiation detector includes a scintillator and an array of detector pixels as set forth in the previous paragraph arranged to receive bursts of light produced by the scintillator in response to received radiation.

15 According to another aspect, a time-of-flight positron emission tomography (TOF-PET) imaging system is disclosed. A plurality of radiation detectors as set forth in the previous two paragraphs are disposed to detect gamma rays emitted from an imaging region. Gamma ray pair detection circuitry identifies two substantially simultaneous gamma ray detections by two of the radiation detectors. A line of response processor determines a spatial line of response connecting the two gamma ray detections. A time of flight processor localizes a positron-electron annihilation event along the line of response based on a time difference between the two substantially simultaneous gamma ray detections.

20 According to another aspect, a method is performed in conjunction with a scintillator that converts a radiation particle to a burst of light. Digital circuitry is switched from a first digital value to a second digital value responsive to detection of a photon by a photodiode biased in a breakdown region by the digital circuitry to define a switching event. A trigger signal indicative of a start of an integration time period is generated responsive to a selected number of one or more said switching events associated with a plurality of said photodiodes. A count of switching events associated with the plurality of said photodiodes is accumulated over the integration time period.

30

In some embodiments, the method further includes generating a digital timestamp associated with the accumulating over the integration time period. The digital timestamp is based on a time of generation of the trigger signal and a reference time signal.

5 According to another aspect, a radiation detector is disclosed, including a scintillator and circuitry for performing the method set forth in the previous paragraph.

One advantage resides in providing high data-rate radiation detection for TOF-PET, single photon emission computed tomography (SPECT), transmission computed tomography (CT), astronomy, and other applications.

Another advantage resides in providing a digital radiation detector output.

10 Another advantage resides in providing a digitally timestamped detector output.

Another advantage resides in providing improved spatial detector resolution.

Another advantage resides in improved detector device manufacturing yield with low sensitivity to temperature, bias voltage, and process parameters.

15 Numerous additional advantages and benefits will become apparent to those of ordinary skill in the art upon reading the following detailed description.

The invention may take form in various components and arrangements of components, and in various process operations and arrangements of process operations. The drawings are only for the purpose of illustrating preferred embodiments and are not to
20 be construed as limiting the invention.

FIGURE 1 diagrammatically shows a TOF-PET system employing high-speed pixelated digital radiation detectors.

FIGURE 2 diagrammatically shows a cross-sectional view of one of the pixelated digital radiation detectors of the TOF-PET system of FIGURE 1.

25 FIGURE 3 shows a general circuit diagram of one of the detector cells of the pixelated digital radiation detector.

FIGURE 4A shows a more detailed circuit diagram of one embodiment of one of the detector cells.

30 FIGURE 4B shows a more detailed circuit diagram of another embodiment of one of the detector cells.

FIGURE 5 shows a circuit diagram of one pixel of the pixelated digital radiation detector.

FIGURE 6 shows a circuit diagram of one the pixelated digital radiation detectors.

FIGURE 7 shows a cross-sectional view of one physical layout embodiment of the pixelated digital radiation detector, in which the photodiodes define a photodiode layer and the digital circuitry is disposed in a digital circuitry layer separate from and electrically coupled with the photodiode layer.

FIGURE 8 shows a perspective view of another physical layout embodiment of the pixelated digital radiation detector, in which the photodiodes define a photodiode layer and the digital circuitry is disposed in the photodiode layer interspersed amongst the photodiodes.

FIGURE 9 shows a plan view of the light-sensitive area of a variant device which includes the pixelated digital radiation detector area and an additional proportional photodiode that produces an analog photocurrent when the flux of photons is high enough to saturate the pixelated digital radiation detector area.

FIGURE 10 shows an illustrative example of the measurement setup used in the first stage of a defective cell disablement process for detectors including analog circuitry.

FIGURE 11 shows a block schematic of one imaging counter cell.

FIGURE 12 shows a sensor block diagram.

FIGURE 13 shows a photodetector incorporating a fuse for disablement.

With reference to FIGURE 1, a time-of-flight positron emission tomography (TOF-PET) scanner **8** includes a plurality of radiation detectors **10** arranged to view an imaging region **12**. In FIGURE 1, the plurality of radiation detectors **10** are arranged in several rings of detectors along an axial direction; however, other arrangements of radiation detectors can be used. Moreover, it is to be appreciated that the plurality of radiation detectors **10** is diagrammatically illustrated; typically the radiation detectors are housed within a housing **14** of the scanner **8** and thus are not visible from the outside, and typically each ring of radiation detectors includes hundreds or thousands of radiation detectors. In some PET scanners, only a single ring of radiation detectors is provided, in others, two, three, four, five, or more rings of radiation detectors are provided. It should be

appreciated that detector heads can be used in place of the detector ring structure shown in the Figures. The TOF-PET scanner **8** includes a couch **16** or other support for positioning a human patient or other imaging subject in the imaging region **12**. Optionally, the couch **16** is linearly movable in the axial direction generally transverse to the rings of radiation detectors **10** to facilitate acquisition of three-dimensional imaging data. Additionally or alternatively, the imaging subject can be held stationary, and the plurality of rings of radiation detectors used to acquire three-dimensional TOF-PET imaging data. In yet other embodiments, only a single ring of detectors is provided, the imaging subject remains stationary, and the resulting image is two-dimensional.

10 A suitable radiopharmaceutical is administered to the patient or other imaging subject prior to initiation of TOF-PET imaging. The radiopharmaceutical includes a radioactive substance that undergoes radioactive decay events that emit positrons. The positrons rapidly annihilate with nearby electrons of the imaging subject. The resulting positron-electron annihilation event produces two oppositely directed gamma rays having
15 energies of 511 keV. The gamma rays travel at the speed of light, i.e. $\sim 3 \times 10^8$ meters/sec. Since the imaging region **12** typically has a diameter or other characteristic dimension of about two meters or less, the time-of-flight for a gamma particle from the position of the positron-electron annihilation event to one of the detectors of the plurality of radiation detectors **10** is about a few nanoseconds or less. Thus, the two oppositely directed gamma
20 rays strike two of the radiation detectors substantially simultaneously.

With continuing reference to FIGURE 1 and with further reference to FIGURE 2, each radiation detector **10** includes a scintillator **20** that produces a scintillation or burst of light when the gamma ray strikes the scintillator **20**. The burst of light is received by an array of detector pixels **22** monolithically disposed on a silicon substrate **24**. As will be
25 described, the detector pixels **22** are digital detector pixels that output values including a digital representation of a count of photons (denoted "count" in FIGURE 1) and a digital representation of a timestamp (denoted "timestamp" in FIGURE 1) indicative of when the burst of light corresponding to the scintillation event was detected by the detector pixel **22**. Moreover, the plurality of radiation detectors **10** outputs indexing information including,
30 for example, a detector index (denoted " n_{detector} " in FIGURE 1) indicating which of the radiation detectors **10** output the radiation detection event, and a detector pixel index (denoted " k_{pixel} " in FIGURE 1) indicating which detector pixel or pixels of that radiation

detector detected the burst of light corresponding to the radiation detection event. The scintillator **20** is selected to provide high stopping power for 511 keV gamma rays with rapid temporal decay of the scintillation burst. Some suitable scintillator materials are LSO, LYSO, MLS, LGSO, LaBr and mixtures thereof. It should be appreciated that other
5 scintillator materials can also be used. Although FIGURE 2 shows the scintillator **20** as a single crystal, an array crystals can instead be used. Additionally, an optional planar light pipe **26** can be interposed between the scintillator **20** and the detector pixels **22** to improve transmission of photons of the scintillation light burst to the detector pixels **22**. The scintillator **20** and optional light pipe **26** are optionally encased in a reflective coating **28**
10 which directs scintillation light toward the pixels **22**.

With continuing reference to FIGURE 1, the digital data concerning radiation detection events are processed by a pre-processor **30** that performs selected data processing. For example, if a scintillation event is detected by a plurality of detector pixels, then the pre-processor **30** can employ Anger logic or other processing to identify spatial
15 coordinates r for each radiation detection event and to estimate an energy of the detected radiation particle. The resulting spatial and energy information for each radiation detection event is stored in an events buffer **32**. In other embodiments, the scintillator layer is divided into scintillator tiles sized to correspond with the detector pixels, and each detector pixel is optically coupled with a single scintillator tile. For example, each scintillator tile
20 may include a reflective coating similar to the reflective coating **28** to channel the scintillation photons to the coupled pixel.

A gamma ray pair detection circuitry **34** processes the radiation detection events to identify pairs of substantially simultaneous gamma ray detections belonging to corresponding electron-positron annihilation events. This processing can include, for
25 example, energy windowing (that is, discarding radiation detection events outside of a selected energy filtering window disposed about 511 keV) and coincidence-detecting circuitry (that is, discarding radiation detection event pairs temporally separated from each other by greater than a selected time filtering interval).

When a gamma ray pair is identified, a line-of-response (LOR) processor **38**
30 processes the spatial information pertaining to the two gamma ray detection events (for example, with the two events represented by spatial coordinates r_1 and r_2 , respectively, as computed by the pre-processing **30**) to identify a spatial line of response (LOR) connecting

the two gamma ray detections. Since the two gamma rays emitted by a positron-electron annihilation event are oppositely spatially directed, the electron-positron annihilation event is known to have occurred somewhere on the LOR.

In TOF-PET, the radiation detectors **10** have sufficiently high temporal resolution to detect a time-of-flight difference between the two "substantially simultaneous" gamma ray detections. A time-of-flight processor **40** analyzes the time difference between the times (denoted " t_1 " and " t_2 " in FIGURE 1) of the two gamma ray detection events to localize the positron-electron annihilation event along the LOR. The result, accumulated for a large number of positron-electron annihilation events, is a set of histoprojections **42**. A reconstruction processor **44** reconstructs the set of histoprojections **42** into a reconstructed image using any suitable reconstruction algorithm, such as filtered backprojection or iterative backprojection with correction. The resulting reconstructed image is stored in an images memory **46**, and can be displayed on a user interface **48**, printed, stored, communicated over an intranet or the Internet, or otherwise used. In the illustrated embodiment, the user interface **48** also enables a radiologist or other user to control the TOF-PET scanner **8**; in other embodiments, a separate controller or control computer may be provided.

With reference to FIGURE 3, each pixel **22** of the radiation detector **10** includes an array of detector cells **50**; FIGURE 3 shows a general circuit diagram of one such detector cell **50**. A photodiode **52** is biased in a breakdown region and serves as an input to digitizing circuitry **54**. An output **56** of the digitizing circuitry **54** has a first digital value corresponding to a quiescent state, and transitions to a second digital value responsive to detection of a photon by the photodiode **52**. When the first photon of a scintillation burst is detected, the switching of the output **56** from the first digital value to the second digital value activates an open collector trigger line driver **60** which causes a trigger signal to be applied to a common trigger line or bus **62**. The trigger signal in turn initiates a photon counter/FIFO buffer **66** (where FIFO="first in, first out") that counts the switchings of the digitizing circuitry **54** from the first digital value to the second digital value over an integration time period started by the trigger signal. In some other embodiments, an acquisition enable line **67** initiates the photon counter **66**. A quenching circuit **70**, which may be either active or passive, limits current through the photodiode **52** and is configured to facilitate transition the biasing circuitry from the second digital value back to the first

digital value. Thus, the detector cell **50** may count more than one photon if the detector cell **50** is quenched back to the quiescent first digital value before the integration time period expires. The final count stored in the photon counter/FIFO buffer **66** is accessible via a digital bus **68**.

5 The photodiode **52** is suitably biased in a Geiger-mode type of operation. When the photodiode **52** breaks down, large amount of charge (for example, about 10^6 electrons per received detection in some photodiodes) is generated through the avalanche breakdown process. This charge is transported primarily through the quenching circuit **70**, which has an effective resistance of typically several hundred kilo-ohms to limit the current flowing
10 through the photodiode **52**. With the current thus limited, charge remaining in the photodiode **52** distributes spatially to reduce the electric field in the avalanche region of the photodiode **52**. This screening quenches the avalanche process and causes remaining carriers to be transported by drift out of the avalanche/depletion zone, causing recovery of the photodiode **52**. Typically, the photodiode **52** includes a guard ring (not shown) around
15 the periphery that prevents avalanche breakdown at the edges of the photodiode **52**. The guard ring structure suitably acts like an ordinary reverse-biased PN diode with internal fields too low for the avalanche breakdown to occur.

With reference to FIGURE 4A, a more detailed circuit diagram of one example embodiment detector cell **50'** is described. This embodiment includes a passive quenching
20 circuit **70'** embodied as a quenching resistor. On photon detection, the junction of the photodiode **52** breaks down and an electric current starts to flow through the photodiode **52** and the quenching resistor **70'**. This current causes a voltage drop across the resistor **70'**, thus lowering the potential on the inverter input. The voltage difference relative to V_{DD} should be large enough to drive the inverter output into a "high" state. The switching
25 characteristics of the inverter can be optimized by adjusting the transistor widths. The inverter output returns to a "low" state automatically when the photodiode **52** recovers from the breakdown.

With continuing reference to FIGURE 4A, the detector cell **50'** further implements inhibit logic **74** which does not switch off a faulty detector cell completely, but rather
30 prevents faulty detector cells from generating false triggers. Faulty detector cells will generate excess currents which are taken into account in the trigger validation circuit (described later). When using the detector cells **50'**, the trigger line **62** is tied to a "high"

level via a pull-up resistor (not shown in FIGURE 4A). This way, the triggers from all the detector cells **50'** are logically "or"-ed together and the trigger line **62** is pulled down by that detector cell which detects the first photon.

With reference to FIGURE 4B, a more detailed circuit diagram of another example embodiment detector cell **50''** is described, which includes an active quenching circuit **70''** to speed up the discharge of the junction capacitance of the photodiode **52** to return to the quiescent level, thus reducing the recovery time of the photodiode **52**. Shorter recovery times are expected to lead to higher sensitivity, since a given detector cell **50''** is more likely to count more than one photon during the integration time period when it recovers quickly, and are expected to lead to higher dynamic range and better energy resolution of the detector cell **50''**. The photon counter **66** is enabled either by the trigger line **62** or a dedicated line if a hierarchical trigger network is used, which is pulled down by that detector cell which detects the first photon, and is held down by main pixel logic (not shown in FIGURE 4B) for the integration time period. The number of detected photons accumulated by the photon counter **66** is transferred from the photon counter **66** to a buffer or other digital storage (not shown in FIGURE 4B) on the rising edge of the trigger line **62** or a dedicated readout line. Subsequently, the counter **66** is reset automatically, for example by the low level of the inverted and delayed signal on the trigger line **62**, in preparation for the next scintillation burst detection event. In this arrangement, the dead time between integration time periods can be as low as the buffer transfer time plus the reset time of the counter **66**, which in some embodiments is expected to be less than one nanosecond for CMOS implementations. The detector cell **50''** of FIGURE 4B also includes inhibit logic **74** to prevent false triggers from faulty detector cells.

With reference to FIGURE 5, each pixel **22** of the radiation detector **10** includes a two-dimensional array of detector cells **50** and associated pixel-level digital pixel logic **80**. Digital readout circuitry for the pixel **22** includes pixel-level digital acquisition and readout circuitry **82** and associated circuitry at the detector cell level.

With reference to FIGURES 3 and 5, the digitizing circuitry **54** of each detector cell **50** provides a threshold-based binary digital output indicating whether or not the photodiode **52** of that detector cells has entered breakdown. The digital circuitry **54** outputs a first binary value when the photodiode **52** is in its quiescent state, and transitions to a second binary value when the photodiode current increases beyond a threshold value

indicative of photon detection. The signal of each photodiode **52** is thus digitized at the level of the detector cell **50**. Readout is performed by the pixel-level logic counting the digital transitions of the detector cells to produce a digital pixel output indicative of the number of detected photons. Compared with the summing of analog photodiode currents to generate an analog pixel output as is done in analog SiPMs, the digitize-and-count method of FIGURES 3 and 5 is far less sensitive to bias variations, operating temperature variations, tolerances in components of the quenching circuit **70**, or so forth. As long as these secondary effects do not cause erroneous switching or missed switching of the thresholding digital circuitry **54**, they generally do not affect the energy resolution of the detector cell **50**.

In some readout approaches, the detector cells **50** are addressed like in a standard memory block, using address decoders for the rows and columns of the array of detector cells **50**. This solution provides a sequential readout of the cell data, in which case the pixel-level readout circuitry **82** can be a simple digital accumulator. In other readout approaches, cells lines are read out in parallel, with each line having its own accumulator for the partial sum, and the partial sums are added in a parallel adder tree. In yet other readout approaches, the adders are incorporated into the detection cells, so that the sum of the whole line is obtained while clocking the data out and the line sum is read out from the last detector cell in the line. As the summation in this latter readout approach can be pipelined, the readout architecture is fast, allowing short readout intervals.

If the detector cell-level photon counters **66** or counters of the pixel-level readout circuitry **82** are likely to saturate, then the counters should not be allowed to wrap around. For example, a four-bit counter counting from 0...15 should not be allowed to increment from 15 back to 0. By avoiding wrap-around, saturation of the pixel **22** can be detected when the counter reads its highest value (e.g., 15 for a four-bit counter). The number of bits for avoiding wrap-around depends solely on the minimum anticipated cell recovery time and the maximum length of the integration period. While the integration window is a design parameter, the cell recovery time is of a statistical nature, as photon detection probability is a function of the slowly rising over-voltage during cell recovery. In an actively quenched cell however, a minimum recovery time is defined by the monoflop delay. Thus, in this case, it is possible to design the counter wide enough to avoid

overflow. The digital bus **68** can be either a parallel or a serial bus, depending on space and time constraints.

With continuing reference to FIGURE 5, the digital pixel logic **80** further includes trigger digital circuitry **84**, trigger validation circuitry **85**, and an output buffer **86** that stores the photon count of the pixel **22**. The trigger digital circuitry **84** accesses a reference clock **88** (shown as an electrical trace that is connected to a suitable oscillator or other clocking device not shown in FIGURE 5) to provide a time reference for the trigger digital circuitry **84**. The trigger digital circuitry **84** determines the time stamp of a radiation detection event in a global (for example, scanner) time frame. The trigger digital circuitry modules **84** of all the pixels **22** of the scanner run synchronously at a precision of preferably less than 100ps. The reference signal **88** is used to synchronize the trigger digital circuitry modules **84** of the pixels, providing them with a common time base for the entire scanner. In some embodiments, the integration time period is a fixed time interval starting at the occurrence of the trigger signal. In other embodiments, the integration time period is dynamically terminated when the rate of new counts decreases below a threshold value.

The trigger digital circuitry **84** is also preferably configured to output the digital timestamp (see FIGURE 1) associated with the count. The digital timestamp is based on a time of the trigger signal output by the trigger line driver **60** of the first one of the detector cells **50** that detects a photon from a scintillation burst. The pixel logic **80** optionally still further includes data correction registers and inhibit sequence drivers. Automated test and calibration circuitry **87** is also optionally implemented by the pixel logic **80**. In one test/calibration method, the dark count rate of the pixel **22** (possibly including background counts produced by intrinsic radioactivity of the scintillator **20**) is monitored. In another test/calibration method, an external excitation from a test charge injected into the detector cells **50** is used to test and calibrate the pixel **22**.

With continuing reference to FIGURE 5, it will be appreciated that due to dark currents, crosstalk, thermal excitations, or so forth, it is possible that one of the detector cells **50** may produce an inadvertent trigger signal starting an integration time period. The trigger validation circuitry **85** validates the trigger signal and aborts the integration if it is determined that the trigger signal was false. In one approach, the trigger validation circuitry **85** analyzes the current flowing through the bias network of the pixel **22**. If the

total current stays below a certain current threshold for a selected time interval (e.g. for 10 nanoseconds into the acquisition time period) as measured by a discriminator or other circuitry, then the acquisition is aborted and an automatic reset sequence is initiated in preparation for the next trigger. If the current exceeds the current threshold, the discriminator output will rise to a 'high' level and the acquisition will continue. In some embodiments, rather than using a fixed integration time period, the falling edge of the bias current discriminator is used to detect the end of the scintillation burst so as to adapt the integration time period to substantially match the end of the acquisition interval. This can suppress pile-up in high count rate applications. Another suitable method makes use of the fact that the probability of two thermally generated triggers inside a short time window decreases with the distance of the triggering cells since thermal triggers are generally not correlated. In contrast, the scintillation burst should act on detector cells **50** across the light-sensitive area of the pixel **22**. Thus, the trigger validation circuitry **85** can analyze the triggers from individual detector cells **50**, for example, and validate the trigger signal if two distant lines generate a trigger signal within a selected time window. Other approaches for trigger validation can also be used, such as employing a current sensor with adjustable discriminator set at a trigger threshold higher than the single photon level.

In some other embodiments, the counter **66** is triggered by the acquisition enable line **67**. Triggering on the first photon can be problematic if there is a high background flux of photons unrelated to positron-electron annihilation events. This background can be the result of, for example, a secondary slow decay mode of the scintillator. In such cases, detector cells fire frequently, increasing the dead time of the pixel. To provide more robust counter initiating, at the detector cell level (Figs. 3, 4A, or 4B) the photon counter is enabled by the separate, 'acquisition enable' line **67** which is pulled down by the pixel logic on either the detection of the first photon (trigger line goes down) or by the discriminator of the trigger validation circuit **85** when the current through the bias network has exceeded the user-defined trigger level. This line defines the length of the integration window and is driven by the pixel logic. At the detector pixel level (Fig. 5), the trigger validation circuit **85** is extended to include a multiplexer **89** selecting either the trigger line **62** (for a single photon trigger) or the leading edge discriminator output (for multiple photon trigger) as the input to the time to digital converter/trigger validation circuits. The trigger validation circuit **85** is extended to provide the 'acquisition enable' signal **67** to the

detector cells **50**, **50'**, **50''**. Page: 14

Alternatively, if triggering at single-photon level is not required, a suitable logic can be implemented to generate the trigger signal if a selected number of cells (trigger lines) become active at the same time. This implementation has the practical advantage requiring
5 only digital components. However, in this case, the threshold is defined only statistically. In some other embodiments, the open collector driver is optionally omitted from the detector cells and a modified design is used in the trigger validation circuit.

With continuing reference to FIGURE 5 and with further reference to FIGURE 6, the pixels **22** are arranged in a two-dimensional array to define the light-sensitive surface
10 of the pixelated radiation detector **10**. The embodiment shown in FIGURE 6 uses a pixel readout in which each line of pixels **22** is read out by FIFO buffers **90**. The output buffers **90** each include tristate output buffers allowing the data to be transferred over a shared digital data bus **92**. Optionally, the events are sorted according to their time stamps by the readout arbitration in the line output buffers **90** and also by the shared bus arbitration by
15 output buffer **92**, thus leading to a stream of event data which is sorted over time. This optional feature substantially simplifies the search for coincident events. A data request daisy-chain is suitably used for write access arbitration. The daisy-chained sums are transferred to a radiation detector output buffer **94** for transfer off-chip.

With reference to FIGURES 7 and 8, in some embodiments the digital circuitry
20 (such as the digital biasing circuitry **54**, **54'**, **54''**, digital triggering circuitry **60**, **60'**, **60''**, **84**, and readout digital circuitry **66**, **82**) of the radiation detector **10** are defined by CMOS circuitry disposed on the silicon substrate **24**. Various physical layouts can be used. In a vertically segregated layout shown in FIGURE 7, the photodiodes **52** of the array of detector cells **50**, **50'**, **50''** define a photodiode layer **100**, and the digital circuitry are
25 disposed in a CMOS digital circuitry layer **102** separate from and electrically coupled with the photodiode layer **100**. In an alternative layout shown in FIGURE 8, the photodiodes **52** define a photodiode layer **100'**, and the CMOS digital circuitry (such as the digital biasing circuitry **54**, **54'**, **54''**, digital triggering circuitry **60**, **60'**, **60''**, **84**, and readout digital circuitry **66**, **82**) are disposed in the photodiode layer **100'** interspersed amongst the
30 photodiodes **52**.

Because CMOS logic draws power only when switching states, only those parts of the radiation detector **10** that are continuously actively clocked by the clock **88** will

contribute to the baseline power consumption. Since the pixel 22 is activated by a trigger signal generated by one of the photodiodes 52 which are biased in the breakdown region in the quiescent state, power consumption is dependent on the photon detection rate and, thus, on the flux of received photons plus the dark count rate. Control of power consumption of the pixel 22 can be implemented by deliberately increasing the dead time of an individual pixel between two acquisitions. This could be done automatically by the pixel logic 80 depending on the temperature of the pixel. The temperature of the pixel can be measured directly by a temperature sensor (not shown) or estimated indirectly from the dark count rate of the pixel 22.

10 Since CMOS logic draws power only when switching states, the overall power consumption can be dramatically reduced by using a CMOS implementation over an analog implementation. For example, in some embodiments of an analog implementation, the power consumption per channel is 30mW and the global part of the chip is 162mW. For a more practical implementation, such as on a clinical apparatus with 28,336 channels or 1890 chips, the power consumption would be a constant 1156W. On the other hand, the power consumption for a CMOS implementation, such as the various implementations described herein, has two different values, a static value and a dynamic value. The static power consumption is the power required when there are no counts and hence no switching of states. It does include power for the logic of for the dynamic switching as the logic must be ready to receive counts. The dynamic power consumption is the power required when the detector is actively receiving counts, and hence switching states. The power consumption in active state is dependent on the amount of activity; the more counts and switching of states, the power that is required. The static power consumption for a similar 1890 chip detector is about 10W or less. The dynamic power consumption can vary, depending on the activity, but is typically about 300W or less.

25 A problem can arise if the scintillation burst of light produces a flux of photons that is high enough to cause substantially all of the detector cells 50, 50', 50'' of one or more of the pixels 22 to transition from the first digital state to the second digital state during the integration time period. In this case, the pixel 22 saturates, and the actual intensity (that is, the flux of photons) is not accurately measured. This saturation problem can be addressed in various ways.

In one approach, the photosensitive area defined by the photodiodes **52** is broken into a larger number of smaller photodiodes. The reduced area of each photodiode reduces the likelihood that it will detect a photon. The larger total number of photodiodes provides higher pixel-level sensitivity to the flux of photons, although it generally does not fully
5 compensate for the reduced area of each cell. The detector cells should have some separation to reduce optical crosstalk between neighboring detector cells. Typically, the separation of the cells is in the order of several microns or less, when trenches filled with opaque material are used for the separation. Thus, increasing the number of cells generally reduces the ratio of sensitive area to the total area of the cell to some degree. Additionally,
10 increasing the number of detector cells, while keeping the cell size constant, typically leads to a proportional increase of the dark count rate.

With reference to FIGURE 9, in another approach for addressing the saturation problem, a proportional photodiode **110** is included in the photosensitive area. The proportional photodiode **110** is larger than the photodiodes **52** used in digital detection.
15 The proportional photodiode **110** is configured to produce an analog photocurrent proportional to the flux of photons impinging upon the pixel **22** when said flux of photons is high enough to cause substantially all of the detector cells **50**, **50'**, **50''** of the pixel **22** to transition from the first digital state to the second digital state during the integration time period. Although shown along one side of the array of pixels **22** for simplicity of
20 fabrication, the proportional photodiode **110** can be located in other positions respective to the array, such as centered in the array or at a corner of the array. Moreover, in some embodiments the proportional photodiode **110** may be distributed as a plurality of smaller electrically interconnected proportional photodiodes, such as a proportional photodiode located at each corner of the array of pixels **22**. In the variation of FIGURE 9, the trigger
25 signal output by the first one of the photodiodes **52** to detect a photon is still suitably used to provide the timing information for the gamma ray detection event. Thus, the timestamp output by the radiation detector **10** is used; however, if the digital photodiodes **52** saturate, then the photocurrent produced by the proportional photodiode **110** is used to indicate photon flux intensity rather than using the digital count. The proportional photodiode **110**
30 can be a conventional PIN diode, an avalanche photodiode with integrated analog or digital readout circuitry, or the like.

The pixelated digital radiation detectors are described herein in conjunction with an example TOF-PET application. However, the skilled artisan can readily adapt the disclosed pixelated digital radiation detectors for other application, such as single-photon emission computed tomography (SPECT) imaging, transmission computed tomography (CT) imaging, astronomy applications, and so forth. For radiation detection applications in which the photodiodes 52 are directly sensitive to the radiation, the scintillator 20 is suitably omitted from the radiation detector 10.

One skilled in the art should understand that while most of the embodiments have been described in conjunction with digital circuitry, portions of the invention can be implemented in conjunction with analog circuitry. For example, the following description provides a method of disabling defective cells in an analog circuitry system. Such embodiments are incorporated within the scope of this disclosure.

A defective cell disabling method for an analog circuit system can comprise of two separate stages, namely a sensing stage and a calibration stage. During the sensing stage, a SiPM array or device under test (DUT) is biased at the nominal bias voltage above threshold in a light-tight setup. The Geiger-discharge in semiconductors generates secondary light photons, approximately 3 per 100,000 electrons in the junction on average. Thus, a cell with gain 1,000,000 will generate about 30 optical photons. The average wavelength of these photons is about 1 μ m, thereby enabling the photons to travel large distances in silicon before being absorbed. Some of these photons trigger breakdowns in neighboring cells, commonly referred to as optical crosstalk, if proper shielding is not used. Other photons can escape the silicon and can be detected by appropriate single photon detectors. The sensing detectors must be 1:1 coupled to the DUT cells. Thus, the trigger rate of the sensing detectors can then be directly associated with the dark count rate of individual cells. Additional measurement of the charge pulse of the DUT can be used to directly measure the gain and its variation for individual DUT cells. However to collect sufficient statistics, such measurement would likely mean a significant increase of the measurement time.

Based on the data acquired in the sensing stage, a laser beam will disable faulty cells. Additionally, the number of active cells per pixel can be adjusted to equalize the dynamic range of the pixels, if required. In some implementations, a fuse is used to disable the faulty cells. While a fuse would undesirably consume additional area, this can be

minimized if the fuse is placed over the guard ring. Another alternative would be to cut the poly resistor itself.

An illustrative example of the measurement setup used in the first stage is shown in Figure 10. In Figure 10, a single photon counter array **200** is 1:1 coupled to the DUT **210** using a collimator structure **220**. One skilled in the art should understand that if the sensing detector has the same pixel size as the DUT, proximity coupling could be used to increase the sensitivity of the system. The single photon counter array **200** must have significantly lower dark count rate and thus has to be cooled down to at least -50°C . Each detector **230** in the photon counter array **200** is triggered by photons emitted by the Geiger-mode discharge. The detector indicates the event by pulling down the row and column lines and starting a hold-off interval to avoid double counting of the same event. The length of the hold-off interval must be adjusted to the recovery time of the DUT. An active quenching/recharge circuit **240** can be used to obtain well-defined hold-off intervals. Additional circuits can be used to measure the charge of the pulse in correlation to the coordinates of the event. A block schematic of one imaging counter cell is shown in Figure 11, while a sensor block diagram is shown in Figure 12.

Increasing the DUT temperature can be used to accelerate the measurement. In the calibration stage, the pixel dark count rate and gain data is used to select a subset of cells that will be disabled. This can be any number of defective cells as well as other cells that can be disabled to provide uniformity. To achieve this, a laser is used to cut the fuses in these cells, as illustrated in the modified detector cell shown in Figure 13.

Regardless of whether a digital or analog disablement process is used, a report can be generated allowing a user to determine how many cells were disabled because they were deemed faulty. The report can further provide the location of the disabled faulty cells. The location of the disabled faulty cells can, in some embodiments, be used to disable other cells. Typically this would be done in some sort of geometrical pattern to allow for more uniform detection of radiation about the detector. Furthermore, the disablement of other cells can be automatic, in response to manual input or feedback, or a combination thereof.

The resulting silicon photomultiplier array will have lower dark count rate at the expense of decreased sensitivity because of the area lost due to dead cells. The loss in dynamic range can be accounted for beforehand by integrating higher number of smaller-sized cells in the pixels. It should also be appreciated that the fuse implementation can be

used in combination with digital circuitry. For example, the fuse can be used for calibration, while the digital circuitry is used for the count detection. Other embodiments incorporating these types of ideas are also contemplated by this disclosure.

In some embodiments in which a trigger at the single photon level is not needed, a
5 leading edge discriminator can be used to generate the trigger signal and to suppress dark counts. In other embodiments the trigger signal can be generated digitally by applying a logical operation on the trigger lines. For example, a pixel can be subdivided into two halves, or blocks, and the trigger signal is only generated if both halves detect the photon. In such embodiments, the number and size of the blocks can be adjusted to set the average
10 threshold and the selectivity. Of course, other similar designs can be implemented, including, but not limited to, other geometries and other ways of correlating pixel blocks.

The invention has been described with reference to the preferred embodiments. Obviously, modifications and alterations will occur to others upon reading and understanding the preceding detailed description. It is intended that the invention be
15 construed as including all such modifications and alterations insofar as they come within the scope of the appended claims or the equivalents thereof.

CLAIMS

Having described the preferred embodiments, the invention is now claimed to be:

1. A detector pixel (22) for use in conjunction with a scintillator that converts a radiation particle to a burst of light, the detector pixel comprising:

an array of detector cells (50, 50', 50''), each detector cell including a photodiode (52) biased in a breakdown region and digital circuitry (54, 54', 54'') coupled with the photodiode, the digital circuitry being configured to output a first digital value in a quiescent state and a second digital value responsive to detection of a photon by the photodiode;

digital triggering circuitry (60, 60', 60'', 84) configured to output a trigger signal indicative of a start of an integration time period responsive to a selected number of one or more of the detector cells transitioning from the first digital value to the second digital value; and

readout digital circuitry (66, 82) that accumulates a count of a number of transitions of detector cells of the array of detector cells from outputting the first digital value to outputting the second digital value over the integration time period.

2. The detector pixel (22) as set forth in claim 1, wherein each detector cell (50, 50', 50'') further includes:

quenching circuitry (70, 70', 70'') configured to transition the detector cell back to the quiescent state after detection of a photon by the photodiode.

3. The detector pixel (22) as set forth in claim 1, further including:

trigger validation circuitry (85) that monitors a current in the detector pixel (50, 50', 50'') and aborts the accumulation of the count responsive to an abort criterion.

4. The detector pixel (22) as set forth in claim 1, wherein the readout digital circuitry (66, 82) includes:

a buffer (66) associated with each detector cell (50, 50', 50'') that buffers the second digital value; and

pixel-level readout circuitry (82) configured to sequentially accumulate the buffers (66) associated with the detector cells having the second digital value to produce the count.

5. The detector pixel (22) as set forth in claim 1, wherein the readout digital circuitry (66, 82) includes:

an accumulator (66) associated with each detector cell, each accumulator configured to accumulate transitions of the associated detector cell from outputting the first digital value to outputting the second digital value over the integration time period; and

adding circuitry (82) that sums the values stored in the accumulators at the end of the integration time period to produce the count.

6. The detector pixel (22) as set forth in claim 1, wherein the digital triggering circuitry (60, 60', 60", 84) includes:

digital timestamp circuitry (84) configured to output a digital timestamp associated with the count, the digital timestamp being based on a time of the trigger signal relative to a time reference signal (88).

7. The detector pixel (22) as set forth in claim 1, further including:

a proportional photodiode (110) configured to produce an analog photocurrent proportional to a flux of photons impinging upon the detector pixel (22);

digital time stamp circuitry (84) connected to the array of detector cells (50, 50', 50") to create a timestamp based on a time of the trigger signal that indicates a time of receipt of the flux of photons.

8. A radiation detector (10) comprising:

a scintillator (20); and

an array of detector pixels (22) as set forth in claim 1 arranged to receive bursts of light produced by the scintillator in response to received radiation.

9. The radiation detector (10) as set forth in claim 8, wherein the array of pixels (22) are disposed monolithically on a common silicon substrate (24).

10. The radiation detector (10) as set forth in claim 9, wherein (i) the photodiodes (52) of the array of detector cells (50, 50', 50'') define a photodiode layer (100), and (ii) the digital circuitry (54, 54', 54''), digital triggering circuitry (60, 60', 60'', 84), and readout digital circuitry (66, 82) define a digital circuitry layer (102) separate from and electrically coupled with the photodiode layer.

11. The radiation detector (10) as set forth in claim 9, wherein (i) the photodiodes (52) of the array of detector cells (50, 50', 50'') define a photodiode layer (100'), and (ii) the digital circuitry (54, 54', 54''), digital triggering circuitry (60, 60', 60'', 84), and readout digital circuitry (66, 82) are disposed in the photodiode layer (100') interspersed amongst the photodiodes (52).

12. The radiation detector (10) as set forth in claim 9, wherein at least a substantial portion of the digital circuitry (54, 54', 54''), digital triggering circuitry (60, 60', 60'', 84), and readout digital circuitry (66, 82) are CMOS circuitry.

13. The radiation detector (10) as set forth in claim 9, further including:

 multiplexing circuitry (90, 92, 94) also disposed monolithically on the common silicon substrate (24), the multiplexing circuitry digitally multiplexing counts produced by the readout digital circuitry (66, 82) of the detector pixels (50, 50', 50'') to generate a digital radiation detector output signal.

14. The radiation detector (10) as set forth in claim 1, wherein the digital triggering circuitry (60, 60', 60'', 84) is configured to output a trigger signal indicative of a start of an integration time period responsive to a single detector cell transitioning from the first digital value to the second digital value.

15. The radiation detector (10) as set forth in claim 1, wherein the digital triggering circuitry (60, 60', 60'', 84) is configured to output a trigger signal indicative of a start of an integration time period responsive to a plurality of detector cells transitioning from the first digital value to the second digital value producing a current exceeding a selected triggering current level.

16. A time-of-flight positron emission tomography (TOF-PET) imaging system comprising:

a plurality of radiation detectors (10) as set forth in claim 8 disposed to detect gamma rays emitted from an imaging region (12);

gamma ray pair detection circuitry (34) that identifies two substantially simultaneous gamma ray detections by two of the radiation detectors;

a line of response processor (38) that determines a spatial line of response connecting the two gamma ray detections; and

a time of flight processor (40) that localizes a positron-electron annihilation event along the line of response based on a time difference between the two substantially simultaneous gamma ray detections.

17. A method performed in conjunction with a scintillator that converts a radiation particle to a burst of light, the method comprising:

switching digital circuitry (54, 54', 54'') from a first digital value to a second digital value responsive to detection of a photon by a photodiode (52) biased in a breakdown region, the switching defining a switching event;

generating a trigger signal indicative of a start of an integration time period responsive to a selected number of one or more said switching events associated with a plurality of said photodiodes; and

accumulating a count of switching events associated with the plurality of said photodiodes (52) over the integration time period.

18. The method as set forth in claim 17, further including:

subsequent to a switching event, quenching the photodiode (52) back to a quiescent state corresponding to the first digital value.

19. The method as set forth in claim 17, further including:

monitoring the accumulating; and

aborting the accumulating responsive to occurrence of an abort criterion determined by the monitoring.

20. The method as set forth in claim 17, further including:

generating a digital timestamp associated with the accumulating over the integration time period, the digital timestamp being based on a time of generation of the trigger signal and a reference time signal.

21. The method as set forth in claim 20, further including:

repeating the generating of the trigger signal indicative of the start of an integration time period, the accumulating of the count over the integration time period, and the generating of a digital timestamp associated with the count to generate a plurality of counts each having an associated digital timestamp; and

sorting the counts according to their associated digital timestamps to produce a stream of event data sorted over time.

22. The method as set forth in claim 17, further including:

generating an analog photocurrent proportional to a flux of photons using a separate proportional photodiode (110) when said flux of photons is high enough to cause substantially all of the photodiodes (52) to participate in switching events during the integration time period.

23. A radiation detector including a scintillator and circuitry for performing the method set forth in claim 17.

24. A radiation detector comprising:

a plurality of photodiodes defining a photodiode layer;
digital circuitry for providing one or more digital values responsive to detection of a photon by a photodiode; and
a silicon substrate upon which the digital circuitry is disposed.

25. The radiation detector of claim 24, wherein the digital circuitry forms a digital circuitry layer separate from and electrically coupled to the photodiode layer.

26. The radiation detector claim 24, wherein the digital circuitry is disposed in the photodiode layer at least partially interspersed amongst the plurality of photodiodes.

27. The radiation detector of claim 24, wherein the one or more digital values is a timestamp, a detector index, a detector pixel index, or a count of photons.
28. A detector pixel comprising:
an array of detector cells, each detector cell including a photodiode and digital circuitry coupled to the photodiode,
wherein the digital circuitry transitions from a first digital value output to a second digital value output responsive to detection of a photon by the photodiode.
29. The detector pixel of claim 28 further comprising digital triggering circuitry that provides a trigger signal indicative of an integration period start time when a predetermined number of detector cells transition from the first digital value output to the second digital value output.
30. The detector pixel of claim 28 further comprising readout digital circuitry that counts the transitions of the detector cells from the first digital value output to the second digital value output.
31. The detector pixel of claim 28 further comprising trigger validation circuitry that monitors current in the detector pixel and aborts an accumulation process responsive to an abort criterion.
32. A position emission tomography imaging system comprising:
an imaging region configured to receive an object to be imaged; and
a plurality of detectors disposed at least partially about the imaging region, wherein at least one of the plurality of detectors comprises:
(i) a scintillator;
(ii) a photodiode for detecting photons from the scintillator; and
(iii) digital circuitry for providing one or more digital values responsive to detection of a photon by the photodiode.
33. A method of producing a medical image comprising:

producing scintillation events in response to radiation events;
detecting the scintillation events;
assigning a digital timestamp to the detected scintillation events;
using the digital timestamps in a reconstruction method to produce the medical image.

34. A detector comprising:

a scintillator;
a photodiode biased in a breakdown region; and
digital circuitry that provides a binary digital output indicating whether or not the photodiode has entered breakdown.

35. A detector comprising:

a scintillator;
a photodiode for detecting events from the scintillator; and
circuitry for providing digital values in response to photodiode events, wherein said circuitry operates in a static power consumption mode when there are no photodiode events and operates in a dynamic power consumption mode when there are photodiode events.

36. A detector comprising:

a scintillator;
a photodiode for detecting events from the scintillator; and
circuitry for providing digital values in response to photodiode events, wherein the power consumption required by the detector is at least approximately one third of the power consumption required by an analogous detector with circuitry that provides analog values in response to photodiode events.

37. A method of disabling cells of an imaging detector comprising:

sensing the dark count rate of individual cells of a detector array;
determining which cells are defective based on the dark counts sensed; and
using a laser to cut a fuse associated with the cells determined to be defective.

38. The method of claim 37 further comprising
determining the location of the defective cells; and
disabling one or more non-defective cells based on the location of the defective cells.
39. An imaging detector comprising:
means for sensing the dark count rate of individual cells of a detector array;
means for determining which cells are defective based on the dark counts sensed;
and
means for using a laser to cut a fuse associated with the cells determined to be defective.
40. The imaging detector of claim 39 further comprising:
means for determining the location of the defective cells; and
means for disabling one or more non-defective cells based on the location of the defective cells.
41. An imaging detector comprising:
a scintillator for generating photons in response to radiation;
a plurality of photodetectors for detecting photons generated by the scintillator; and
digital circuitry for providing a digital output in response to photons detected by the plurality of photodetectors, wherein said digital circuitry includes a means of digitally disabling any number of the plurality of photodetectors.
42. The imaging detector of claim 41 wherein the means for disabling the photodetectors disables photodetectors deemed to be faulty.
43. The imaging detector of claim 42 wherein the means for disabling the photodetectors further disables one or more photodetectors in a predefined geometrical relationship to the faulty photodetectors disabled.

44. A calibration method for an imaging detector comprising:
 providing an imaging detector with a plurality of photodetectors;
 testing the responsiveness of the plurality of photodetectors;
 determining which of the photodetectors are faulty; and
 disabling the photodetectors determined to be faulty.
45. The calibration method of claim 44 further comprising disabling one or more photodetectors in a predefined geometrical relationship to the faulty photodetectors disabled.
46. The calibration method of claim 44 further comprising providing a report of the photodetectors disabled.
47. The calibration method of claim 46 wherein the report includes the spatial distribution of the photodetectors disabled.

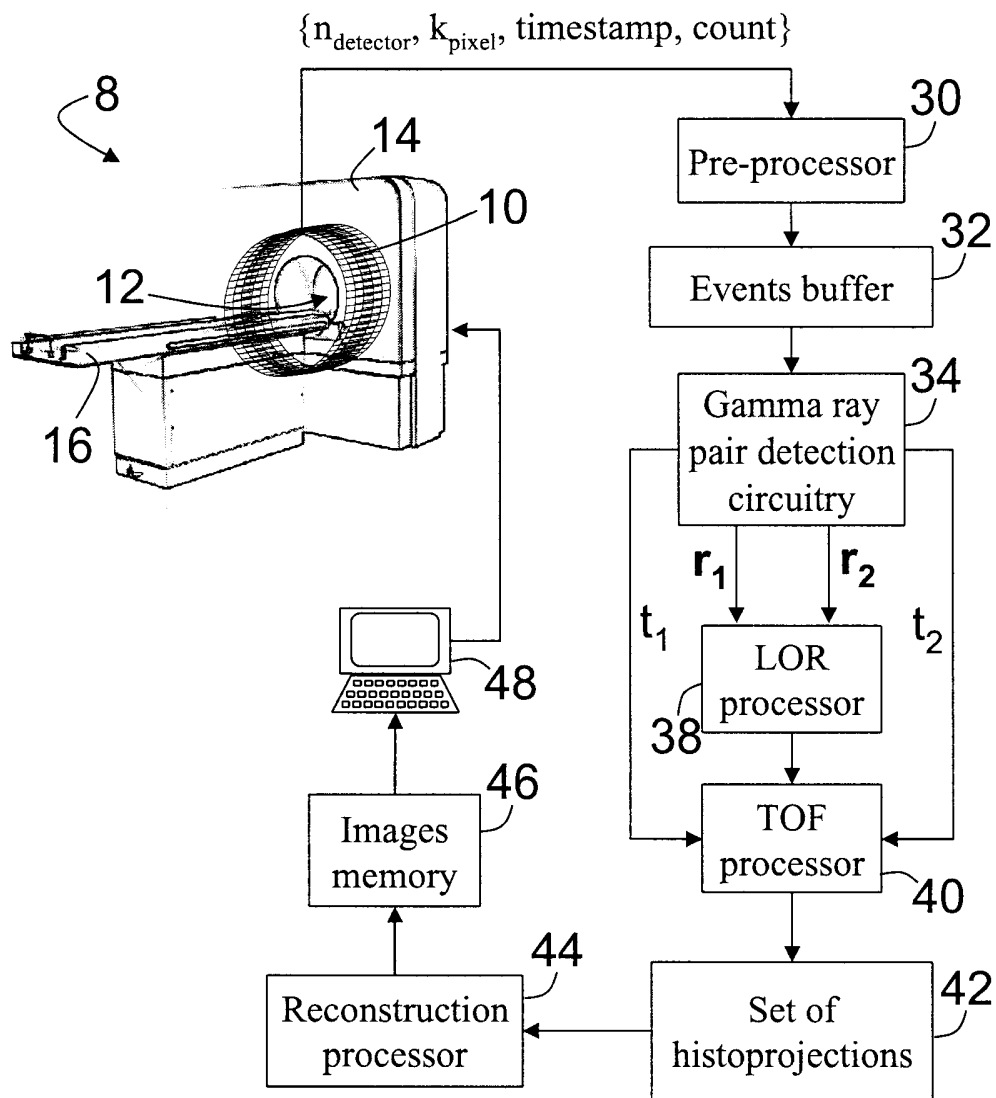

Fig. 1

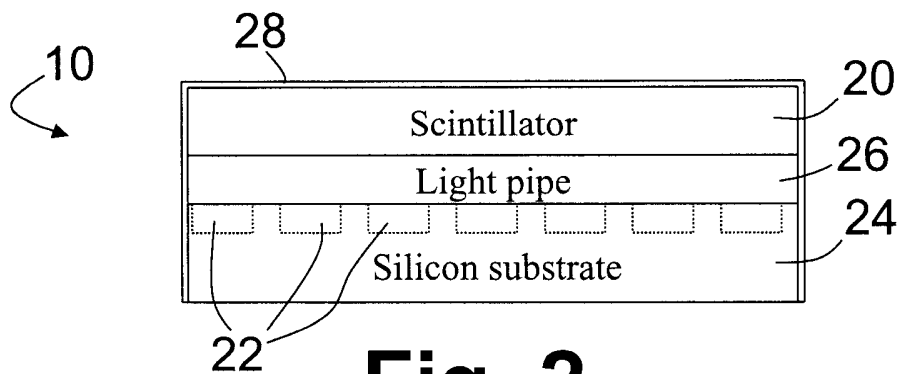

Fig. 2

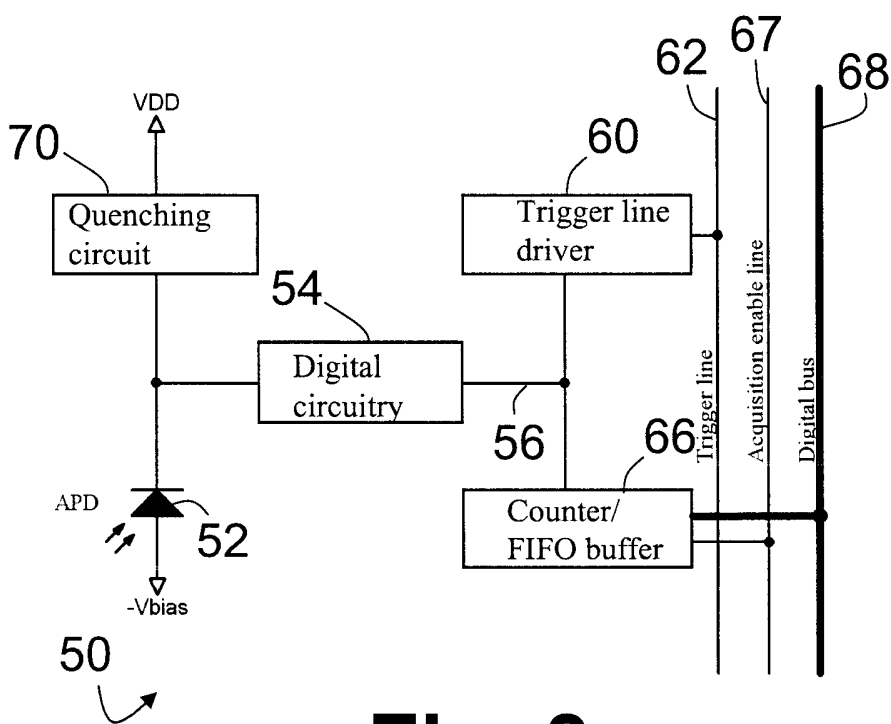

Fig. 3

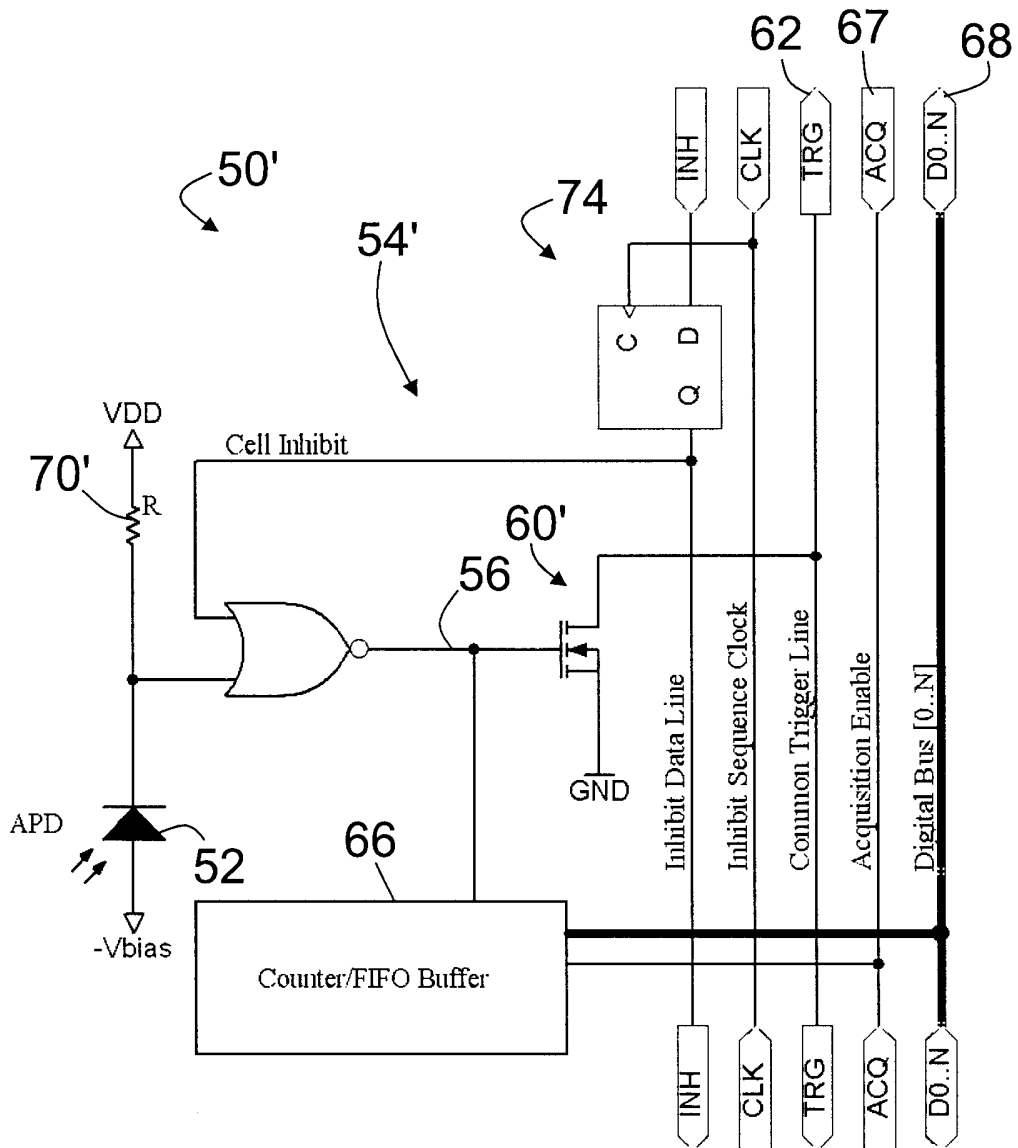

Fig. 4A

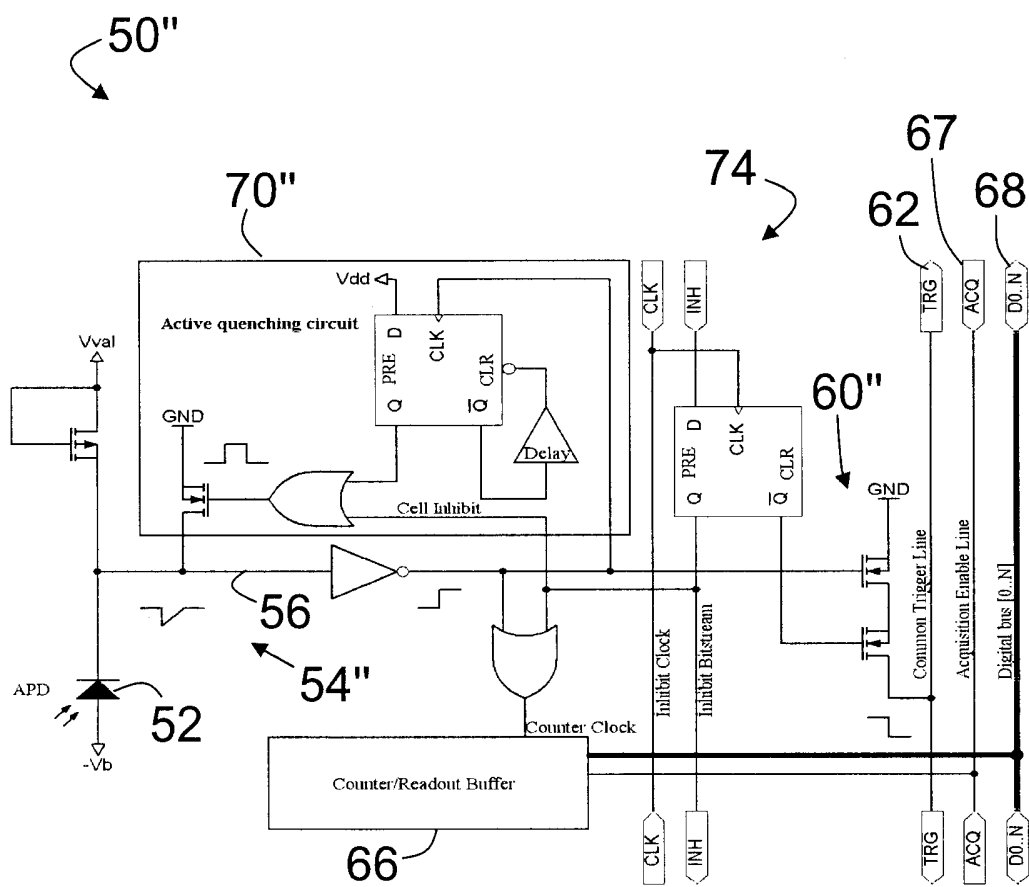

Fig. 4B

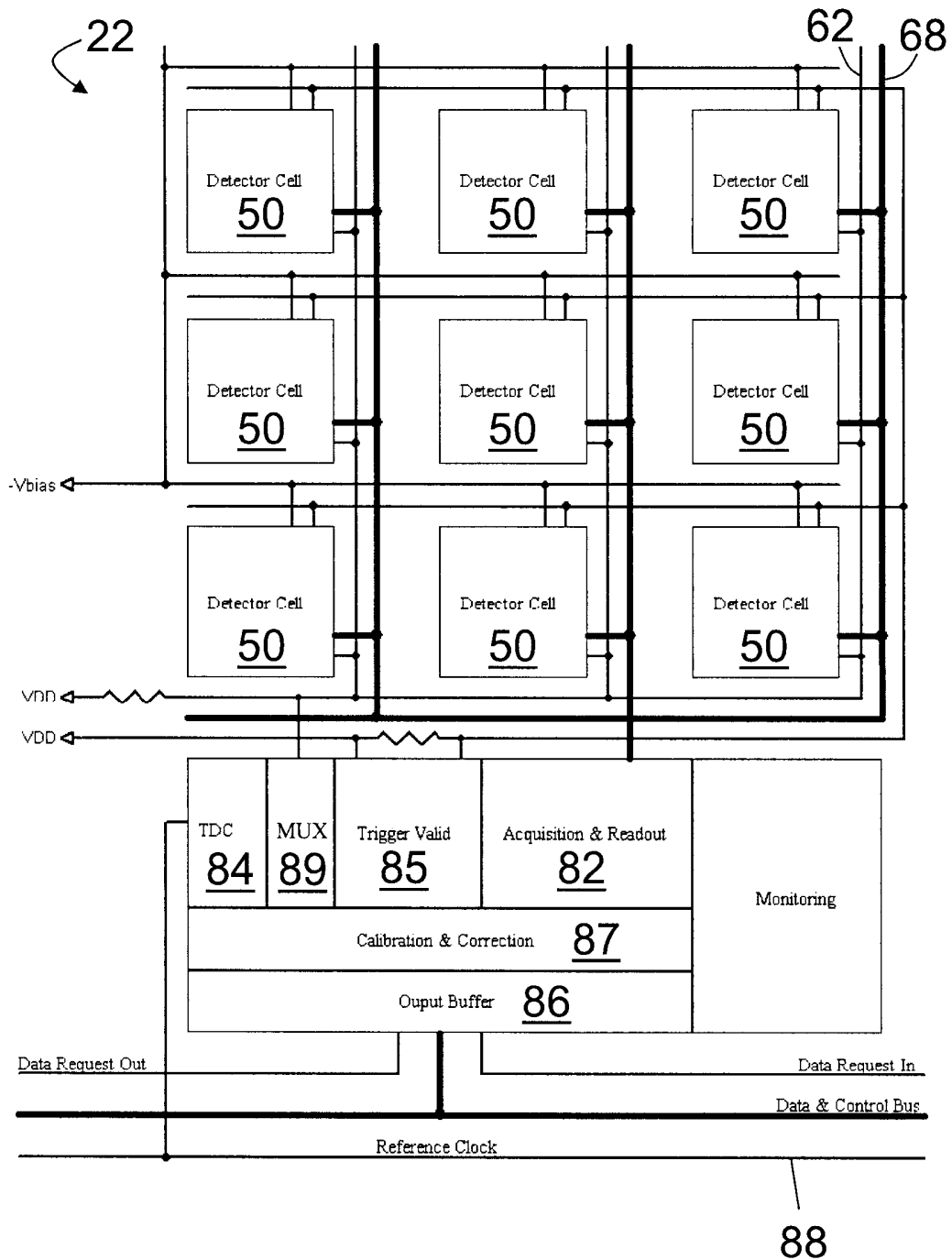

Fig. 5

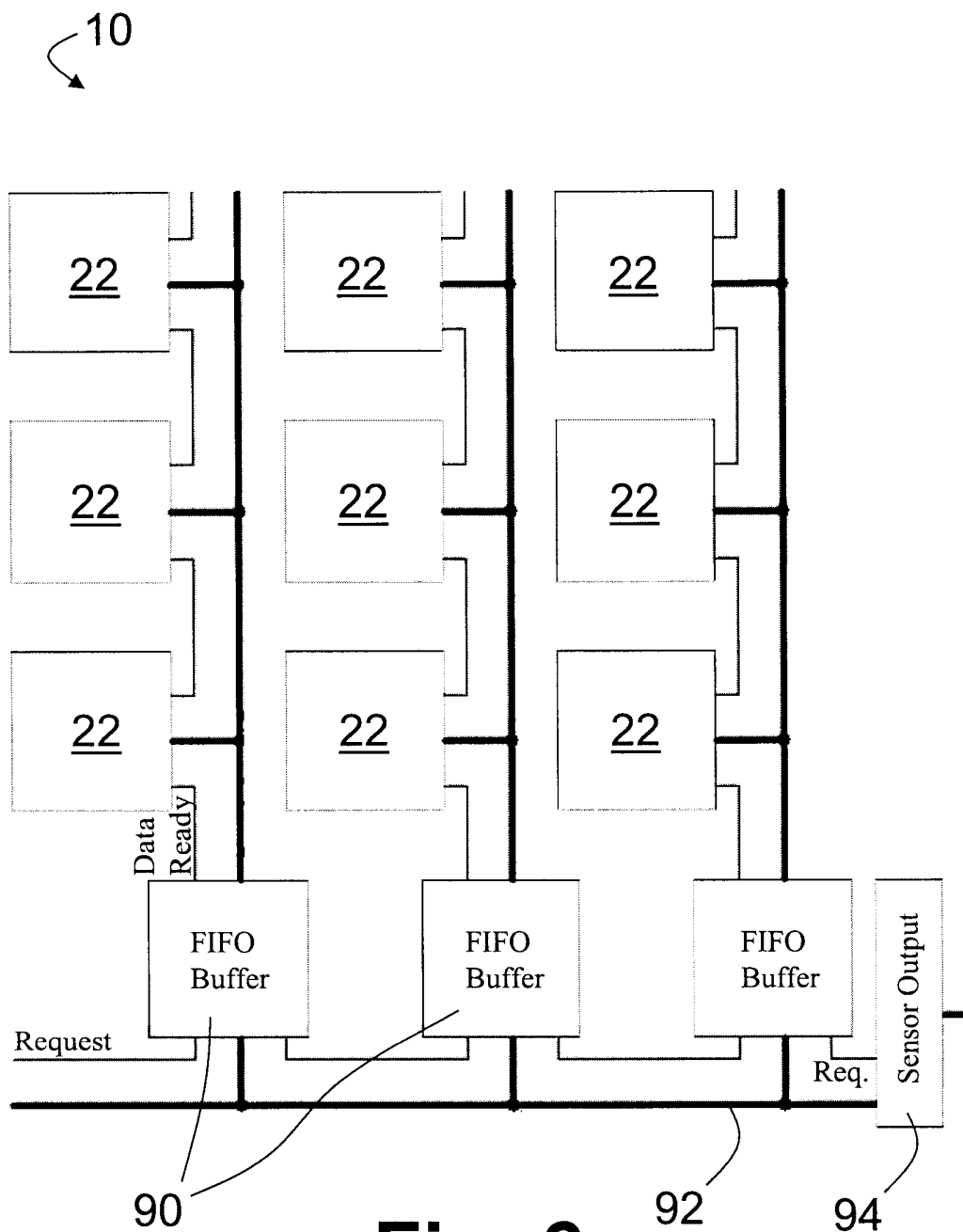

Fig. 6

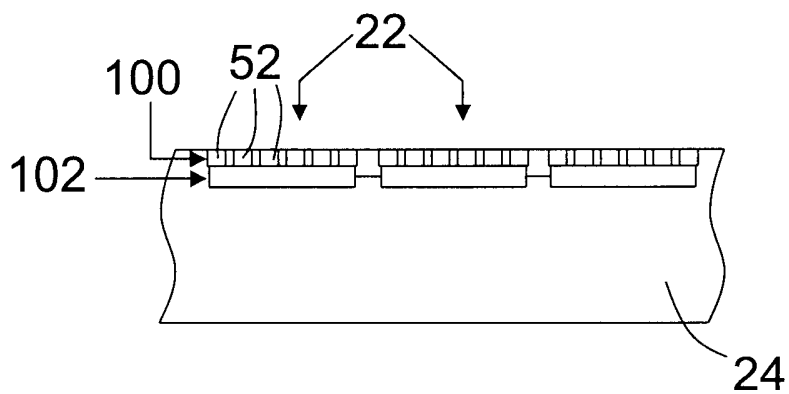

Fig. 7

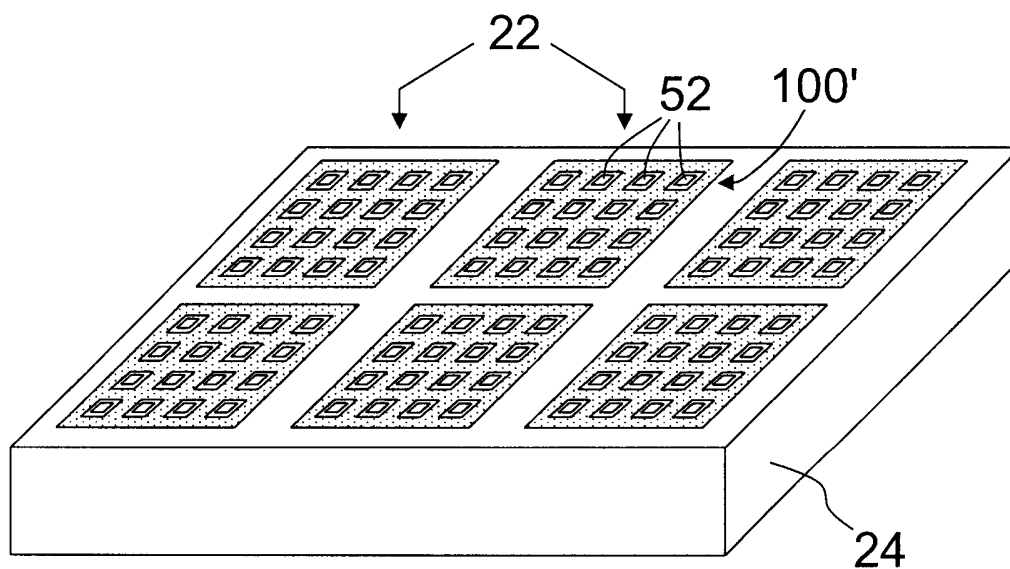

Fig. 8

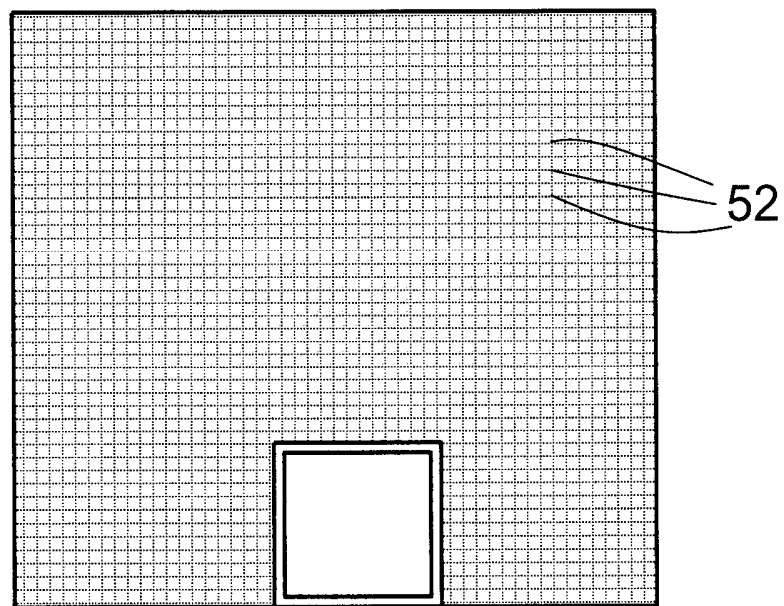

Fig. 9

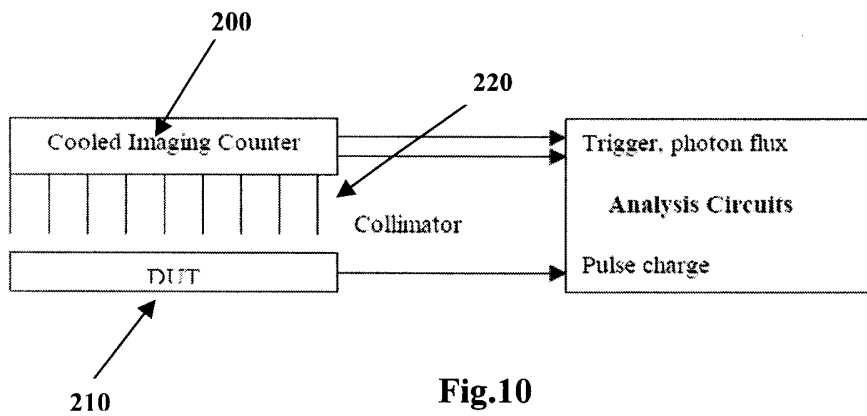

Fig.10

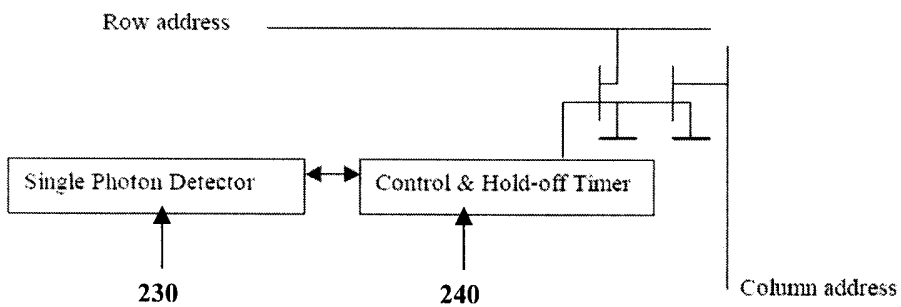

Fig. 11

10/10

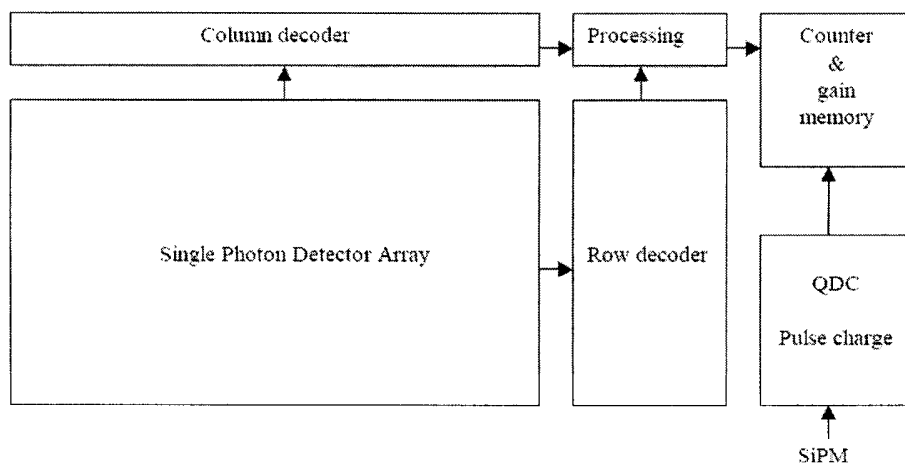

Fig. 12

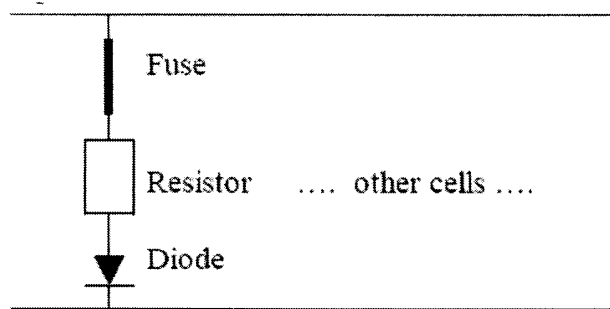

Fig. 13